

Fluid power

Learning systems and services for basic
and further training



FESTO







Contents

Media	8
Workstation systems	24
Training packages	40
Pneumatics training packages	46
Hydraulics training packages	84
Components	122
Services	164

	<p>SNS Industrial Group</p> <p>221 Holiday Inn Drive, Unit 102A Cambridge Ontario N3C 3T2</p> <p>www.snsindustrial.com 226-566-9677 Sales@snsindustrial.com</p>
--	--

Holistic and turnkey training solutions

Everything from a single source



Design, planning, and equipping of complete labs for technology and training

Festo Didactic has set itself the goal of making learning even more effective, using its experience from 50 years of company history to develop learning solutions, as well as lab and workshop equipment for the training sector.

We will support you with the conceptualization, planning and equipping of your individual labs or workshops by means of a comprehensive range of learning systems and a broad spectrum of technologies in the area of technical training. Our range of products and services comprises complete learning systems as well as industrial training and consultation.

The benefits for you

- Security during the planning process and professional consultation during the entire project
- State-of-the-art planning tools plus a range of products which are tailored to your requirements ensure rapid and effective progress with projects.
- Investment security and optimal utilization of laboratories perfectly tailored to your training needs
- Professional lab design based on international standards
- State-of-the-art training equipment through the use of the Festo Didactic learning systems supplemented with products by other market leaders



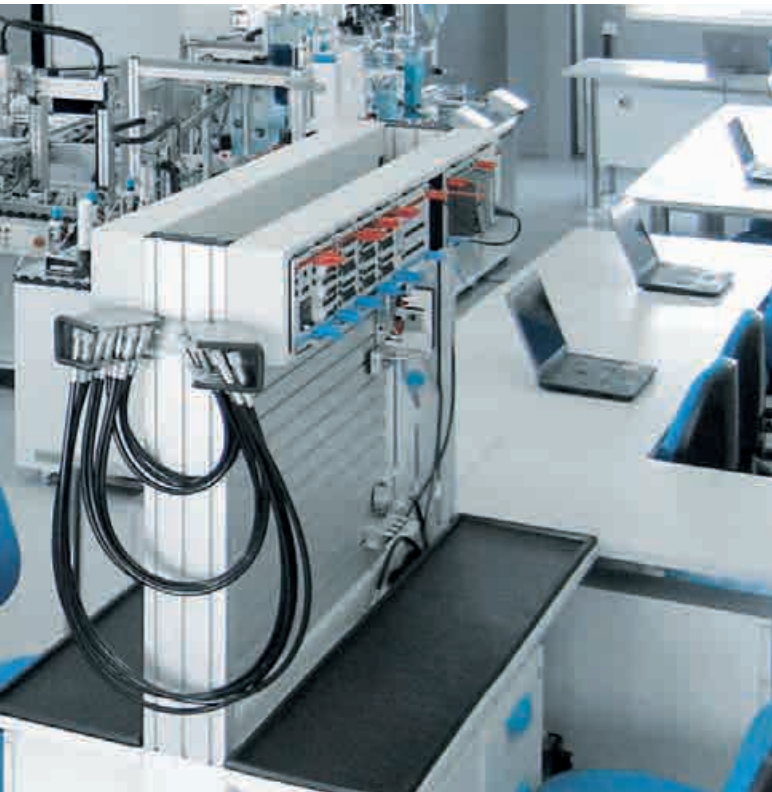

Learning environment for basic and specialized training in pneumatics and hydraulics



Essential technologies

Pneumatics and hydraulics are essential parts of contemporary industrial reality. Air is clean, abundant, easy-to-transfer and store – to cite just a few of the many benefits of pneumatics. Hydraulics offers a solution wherever high pressures and forces are required in industry.

We offer a comprehensive scope of services from project definition and conceptual planning, to installation of equipment and training for:

- Industrial training centers
- Vocational training centers
- Universities and colleges
- Sixth forms
- Knowledge labs



Virtual Tour
 → www.festo-turnkey-solutions.com



Highlights

- Pneumatics and hydraulics training packages
- FluidSIM® is the world's leading simulation software for pneumatics, hydraulics, and electrical engineering
- Connected Learning with Tec2Screen® – an innovative learning method
- Single and group workstations support many modes of learning



Additional learning worlds

Besides fluid engineering, Festo Didactic offers other additional learning arrangements for the following training requirements:

- Multimedia and simulation
- Industry 4.0
- Automation technology
- Welding technology
- Process automation
- Metal working
- Electrical engineering, electronics, and drive technology
- CAD/CAM/CNC

Flexible room concepts

Innovative workbenches

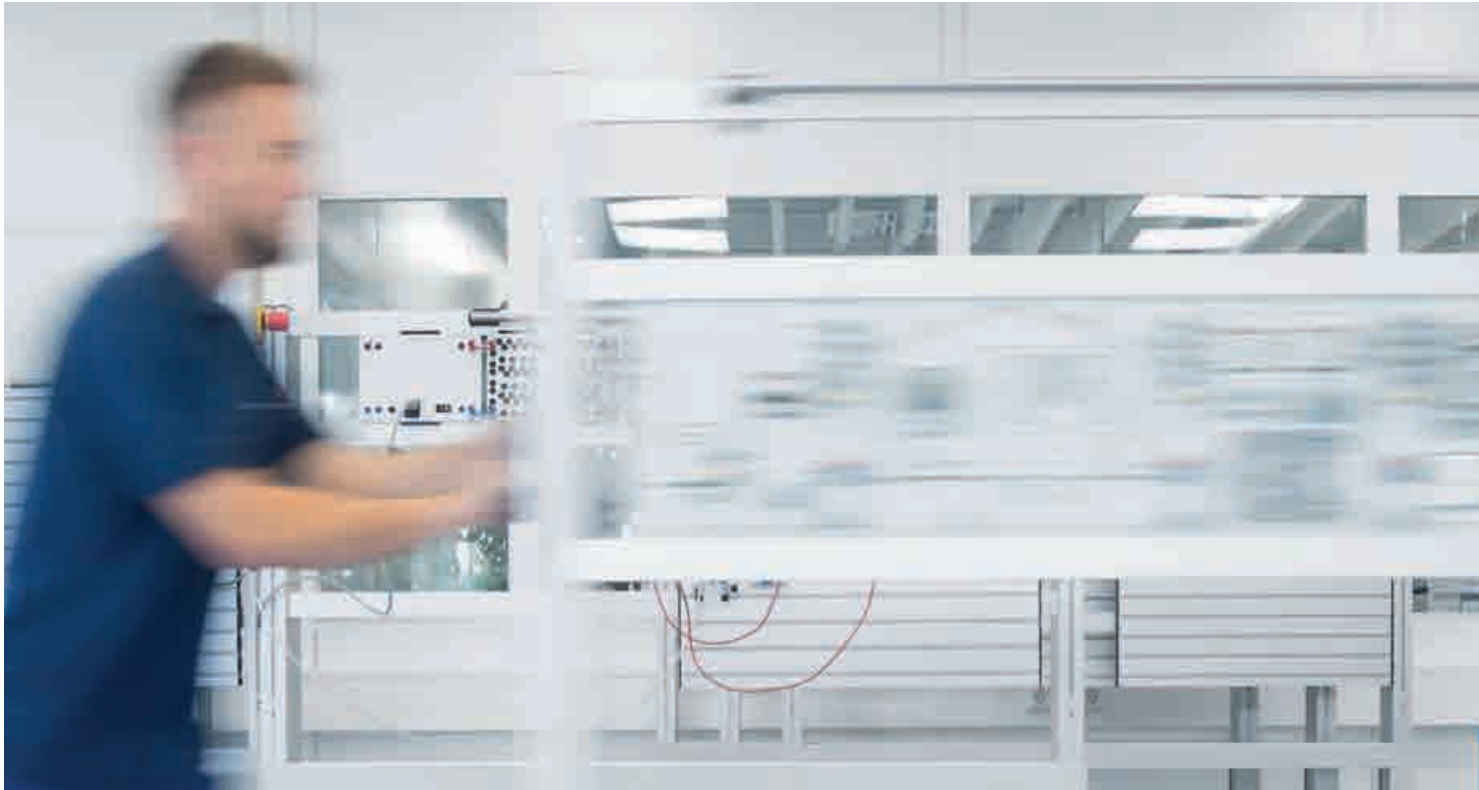

Equipping of learning rooms according to individual requirements

Flexible use of space

We will present you with an individual concept based on the spatial conditions and specific requirements of the location. In doing so we, will focus on cost-effective and optimal use of space, as well as multi-functional equipment. Training in the areas of electrical engineering, pneumatics, or mechatronics, as well as theoretical training or lectures can all take place in the same room. Using the ceiling system, industrial connectors, and universally mobile equipment, the room layout can be adapted within just a few minutes.

Efficient and versatile use of rooms saves space and cost.

Planning and consulting

We offer a special service in which our experts design your equipment setup for you. With your input, we develop an individual concept based on the spatial conditions and specific requirements of the location.

In doing so, we focus on cost-effective and optimized use of space as well as multi-functional equipment. During the consultation you will benefit from our years of experience in the education and training market, and from installing various training centers, complete workshops, and labs.

We take into account the latest safety requirements and guarantee a long service life thanks to our high quality standards. Working closely with architects and planners ensures that every stage of the project runs smoothly.





Multi-functional teaching rooms

- Individual
- Flexible
- Cost-efficient

Our room concept offers individual options for your learning environment equipment. Mobile workbenches and utility supplies that you can fold back up into the ceiling ensure flexible and cost-efficient utilization of rooms.



For additional information regarding flexible room concepts see:
 → www.festo-didactic.com

Main components of room concept



Organized storage

Both workbenches and equipment used can be stored neatly and compactly in intelligent storage systems in the same room or in an adjoining room.

Our overall concept provides the required flexibility.



Workstation system

The mobile supports for the learning systems enable a high degree of flexibility with virtually unlimited options. The workbenches can be quickly and simply adapted to optimize any teaching situation. This refitting capability enables highly efficient room utilization and safety, resulting in great cost effectiveness.



Power supply

The flexible ceiling system is a holistic concept for multi-functional rooms, which enables hands-on and theoretical teaching with appropriate equipment in each case. With power, compressed air, and a data connection directly at the learning location, the ceiling system is ideal for basic and further specialized training.

The didactic concept for a complete learning strategy

Our educational concept for the training packages

- 1 Inform**
 - Read the problem in the **workbook**
 - Understand the exercise
 - Fill any gaps in knowledge
- 2 Plan**
 - Design a circuit with **FluidSIM®**
 - Draw a circuit diagram with parts list
- 3 Implement**
 - Installation and commissioning of the circuit on a **workstation system** with the **training packages**
 - Simple, accessible, and convenient
- 4 Check**
 - Comparison of actual and target status and targeted troubleshooting, e.g., using measuring technology **components**
- 5 Reflect, document**
 - Evaluation of the result, optimization, and professional documentation using the worksheets in the **workbook** and **FluidSIM®** CAD drawings.

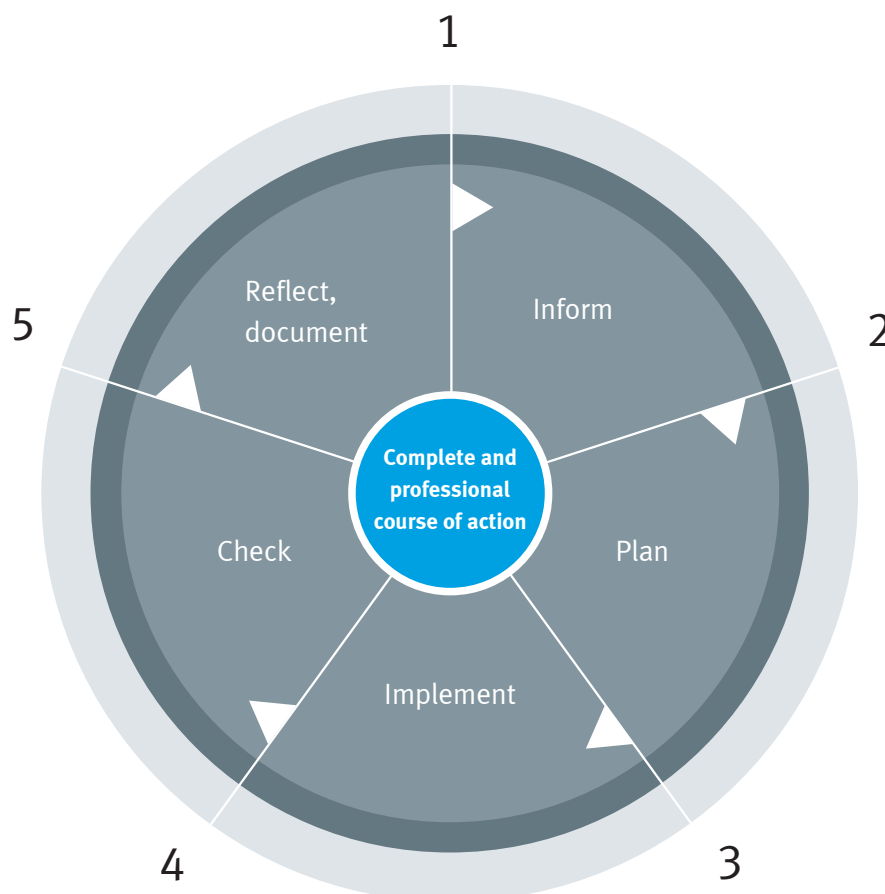

We offer technical training based on the complete learning-strategy model.

Educational and training institutions are facing the challenge of providing the graduates who will be sought after in their local economy. Companies are looking for well-trained and educated employees who are highly competent and responsible.

The Festo Didactic training packages are tailor-made for this objective.

Pneumatics/Hydraulics

Elements of a learning system



The benefits of the Festo Didactic modular learning system

Design your own learning environment according to your educational, organizational, or ergonomic requirements.

Save time using our coordinated learning system consisting of the training package, the workbook as basis for the course, and the appropriate FluidSIM® design and simulation tool.

Add further components to your selected system for your own individual tasks or project ideas.

Media

- Tec2Screen®
- FluidSIM®
- FluidLab®
- Teachware
- Multimedia training programs

Workstation systems

- Profile plate for pneumatics, hydraulics and sensors
- ER frame for control and regulation
- Organized storage for pneumatic components

Training packages

- Pneumatics, hydraulics, and sensors
- Basic level, advanced level, and supplementary equipment sets

Components/accessories

- Add-ons or for customization

Media





Tec2Screen®10

Software12

FluidSIM® 512

Multimedia training programs/WBTs.....14

Courseware.....18

Pneumatics/Hydraulics Poster Set.....20

Pneumatics Textbooks, Workbooks, Training Material.....22

Hydraulics DVD, Textbooks.....23

Tec2Screen®

Connected Learning and Fluid Power



Tec2Screen® Courses Pneumatics

For example:
**Tec2Screen® course –
Energy-efficient movement**

Tec2Screen® Courses Hydraulics

For example:
**Tec2Screen® course –
Flow resistances**

The concept consists of:

- Tec2Screen® app
- Courses
- Simulations
- Tec2Screen Manager for 20 users/workstations
- Learning management system: Classroom Manager Cloud (optional for all other licence levels) full functionality of a learning management system
- Connects
- Tec2Screen® hardware
- Optional learning systems

Exciting courses for explorative learning

Videos, animations, measuring exercises, and test assignments inspire students to explore and discover. The measuring instruments integrated into the courses make interactive troubleshooting exciting.

Completing the courses offline, outside of the lab, is also possible, ensuring that technical knowledge can be learned anywhere at any time.

Training content

- Moving a load efficiently
- Performing a reference measurement of the existing circuit
- Reducing consumption by reducing pressure
- Optimizing flow control
- Shutting off the compressed air supply in the end position

Further courses:

- Energy-efficient clamping
- Energy-efficient lifting
- Energy-efficient gripping

Training content

- Flow types and pressure drop
- Measuring and evaluating the flow resistance of hydraulic lines as a pressure-flow characteristic curve
- Influencing factors on the flow resistance of hydraulic lines

Further courses:

- Quantity curve for a hydraulic power unit
- Pressureless pump circulation
- Dynamic pressure adaptation



What actually is Connected Learning?

Learning methods which frequently supplement and support each other and include the following:

- Practical learning
- Classroom-based learning
- Self-learning

With **Connected Learning**, these methods are fused into a single form of learning. The virtual and the real world are seamlessly integrated. Software and hardware, theory and practice, learner and teacher – Connected Learning promotes intuitive, interactive learning.

Our patented solution for Connected Learning: **Tec2Screen®**. Fun and motivation while learning are guaranteed!

Overview of all Tec2Screen® courses at:
→ www.tec2screen.com



Simulations develop a better understanding of real world applications

As a component of modern training systems, the Tec2Screen® simulations can be used to test and simulate controllers and applications for PLC technology under realistic conditions. The new knowledge encourages practical and safe experimenting without real consequences or the need to purchase additional hardware.



The learning management system

The Classroom Manager Cloud manages courses and simulations as well as self-made documents and materials. The trainer assigns these to the students individually and can simultaneously record their learning progress.



New interfaces: Connects

To explore the connection between the real and the virtual world, we have developed the Connects – plug-in interface modules with a patented interface. The Connects enable direct interaction between software and hardware, and thus direct interaction between theory and practice.

Unique: the signal flow is completely transparent and easy to follow.



The hardware

As a basic unit, the Tec2Screen® base links the iPad® with the patented Connects. The iPad® can also be used as a fully functional tablet, independently of the Tec2Screen®, in the classroom and elsewhere.

Festo Didactic won the 2015 iF Design Award for the Tec2Screen®.



FluidSIM® 5

Pneumatics/Hydraulics/Electrical engineering

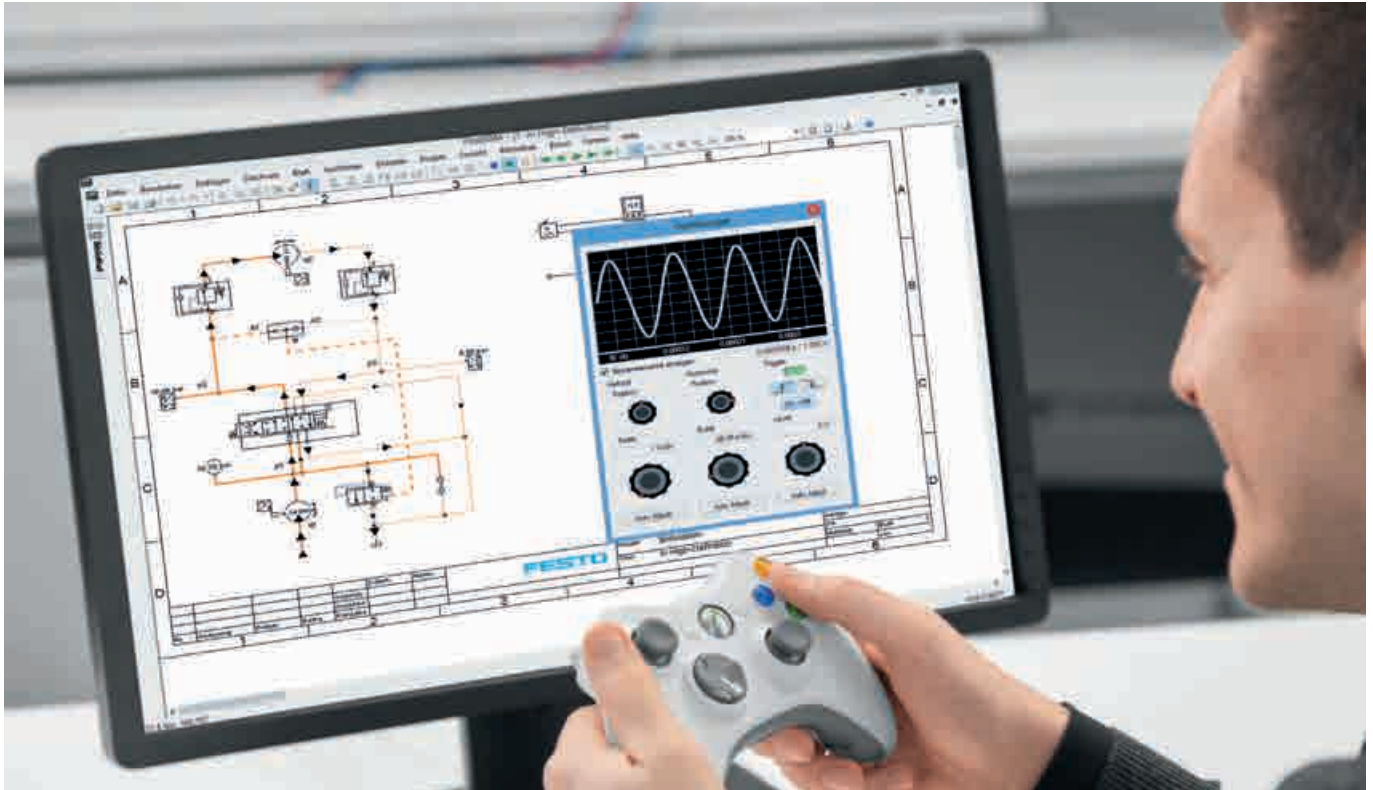

For more than 20 years FluidSIM® has been the world's leading circuit diagram design and simulation program for pneumatic and hydraulics, and now also for electrical engineering. Being able to freely design control systems is motivating and promotes creativity and focus. Beyond that, FluidSIM® provides teachers with a wealth of text, images, and videos for multimedia-based lesson planning. Dive into the world of real-time simulations with your apprentices, specialists, or students and celebrate successful learning at all levels!

One tool for all needs

As a teacher and trainer, you are the expert who masters tasks that are needed to prepare lessons. That is why FluidSIM® 5 offers the expert mode. But your trainees should initially concentrate on the essentials. They can work and learn successfully in the standard mode, which has a reduced range of functions and offers advantages for the learning process.

Testing in real time

Whether in a training environment or in an engineering office, the simulation of control systems and processes has been standard in industry for a long time, helping to minimize crash-based losses and ensuring greater efficiency and improved quality. The parameters of all simulated components are identical to those of the Festo Didactic training packages and can be fully adapted to the characteristics of other components.

The many aspects of GRAFCET

GRAFCET long ago replaced the displacement-step diagram in training. FluidSIM® 5 takes GRAFCET to the next level:

- Editing – for standards-based documentation
- Visualizing – for maximum clarity
- Monitoring – colored signals indicate where the process is running correctly or not at all
- Control – for manufacturer-neutral control of all fluid systems and electrical systems

Speed made visible

The new simulation core of FluidSIM® 5 achieves simulation rates up to 10 kHz. The parameters of all actuators can be precisely adjusted. FluidSIM® 5 writes the simulation results in millisecond cycles and delivers them as a text file! The new simulated oscilloscopes make frequencies up to 100 kHz visible.

Learning with fun and success

Theory is all well and good, but real, hands-on practice provides motivation and promotes successful learning! In many situations, FluidSIM® 5 can be easily used as a controller for the real system: the EasyPort makes it possible – convenient, digital and analog! New: with the joystick, FluidSIM® 5 is not only engaging, but it now also allows several switches and valves to be operated simultaneously.

Wide range – maximum convenience

Pneumatics, hydraulics, electrical engineering: the libraries are available separately or together in the same program. The user decides which of the libraries can be used in the program. All technologies interact optimally in a circuit diagram or project.

Flexible installation and use

Online registration, network license, home usage: FluidSIM® 5 offers many license models that facilitate economical learning scenarios in a school or in a company. A new learner administration function even allows you to provide and monitor licenses for learning groups and to use the software at home.



Professional CAD according to standards

- Convenient drawing thanks to alignment guides and new snap functions
- Easy insertion of new symbols into existing connections
- Variable drawing frames
- Continuous scaling and rotation
- Dimensioning functions
- Intersection calculation of lines, rectangles, and ellipses

Completely according to standard

- All symbols to DIN ISO 1219 or DIN EN 81346-2
- Connection identification according to new equipment identifier
- GRAFCET according to the current standard

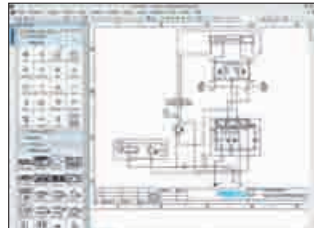

Libraries for new technologies

- Libraries for the pneumatics and hydraulics training packages at all levels, including control technology and proportional technology
- New: drives in pneumatics
- Vacuum technology
- Sensors in pneumatics
- Safety in pneumatic systems
- Mobile hydraulics
- Electrical engineering, electronics
- Circuits with contacts

GRAFCET in various modes

- GrafEdit: create GRAFCETs in compliance with the standard
- GrafView: visualize the control sequence represented as a GRAFCET
- GrafControl: control the process with the GRAFCET, including error simulation and process monitoring
- GrafPLC

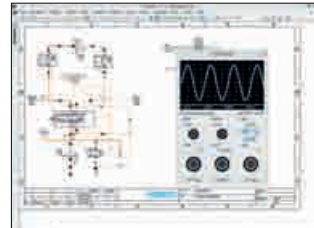

Simulation in high definition

- Signal processing up to 10 kHz
- Virtual oscilloscope for frequencies up to 100 kHz
- Concurrent simulations of all circuits in a project
- Simulated values can be shown at run-time
- Several switches can be operated with the joystick

Learning material included

- Slides, pictures, animations, sectional drawings, video sequences
- Description of the physical-mathematical simulation models
- Training program for FluidSIM® beginners
- Details of all components at the push of a button
- Completed sample presentations for your training course
- Language changeover at run-time
- Multilingual (standard German/English)



Convenient documentation

- Project administration, drawing sheets
- Individual drawing frames in all sizes
- Automatic bills of materials, flow path numbering, switching element tables, terminal diagrams, cables, wiring lists, and tubing lists
- Exports into all common formats

FluidSIM® for homework

- New expansion for administering external users over the Internet
- Administration of learning groups
- Integrated chat functions
- Simple administration by the instructor

Pneumatics

Local installation,
single license de/en/es/fr/pt/ro/ru

Order no. **8024357**

Network installation,
single license de/en/es/fr/pt/ro/ru

Order no. **8024360**

Hydraulics

Local installation,
single license de/en/es/fr/pt/ro/ru

Order no. **8024358**

Network installation,
single license de/en/es/fr/pt/ro/ru

Order no. **8024361**

Electrical engineering

Local installation,
single license de/en/es/fr/pt/ro/ru

Order no. **8024359**

Network installation,
single license de/en/es/fr/pt/ro/ru

Order no. **8024362**

Recommended accessories:

X-Box controller

with cable 8026542

without cable 8032252

System requirements

- Windows XP, Vista, 7, 8, or 10
- Processor with at least 1 gigahertz
- At least 1 GB RAM
- Dual core processor (recommended)

We can meet your needs

Multiple licenses for local or network installation with as many licenses as you need.

New languages – free of charge

In the future, you will receive new language variants free of charge on the Internet. They can be integrated into your existing version via an update.

Visit us on the Internet.

There you will find all the information you need on currently available versions and updates for existing FluidSIM® users.

Multimedia training programs

Pneumatics



Comprehensive pneumatics training. The program is divided into technical knowledge and coursework.

Technical knowledge

This interactive, self-guided program covers the basics of pneumatic control. Participants find practical and theoretical solutions to the key tasks of a basic course on pneumatics, e.g., as part of a basic vocational training course.

Course

In this course, the theory-based technical knowledge is reinforced. A wide range of exercise types makes the course interesting and successful. Participants draw symbols and circuit diagrams, answer multiple-choice questions, and set up and connect circuits in PC-based video clips.

From the table of contents:

- Physical basics (units, properties, laws)
- Energy supply (production, preparation, and distribution of compressed air)
- Circuit diagram (circuit diagram, symbols)
- Drive components (applications, linear drives, rotational drives)
- Valves (designs, directional valves, stop valves, pressure control valves, flow control valves, valve combinations, logic elements)
- Signalling components (manual signalling, endpoint detection)
- Additional requirements

Single license with myleCampus
Online de/en/es/fr/fi/et/el/zh

Order no. **540911**

Electropneumatics

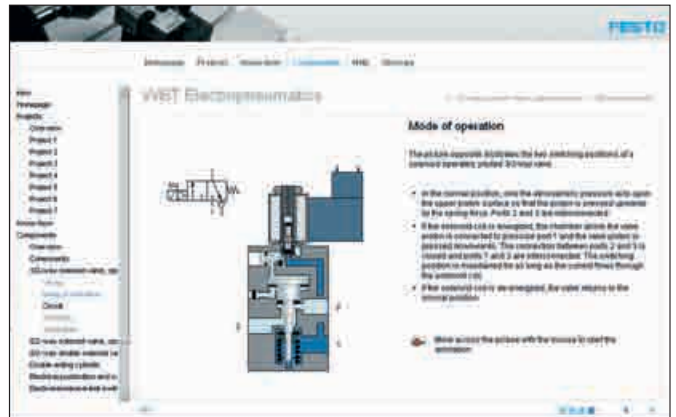

The Electropneumatics training program builds on the Pneumatics training program and reinforces material already learned from hands-on projects. Starting with concrete industrial applications, fundamental electro-pneumatic circuits are produced. With the help of numerous exercises, learned material will be revised, applied, and further developed. During exercises, the program reacts to each answer with varying feedback.

The trainee is supported by the basic knowledge module, which provides fundamental knowledge on electropneumatics in a structured, systematic manner. In the components module, the structure, function and application of typical electro-pneumatic components is described. Various supporting materials are available to complete the exercises, such as PDF documents, a variety of downloads, and a comprehensive glossary.

From the table of contents:

- Advantages and drawbacks of electropneumatics
- Safety in electropneumatic circuits
- Fundamentals of electrical engineering
- Pneumatic circuit diagram
- Electrical circuit diagram
- Basic logic functions
- Direct and indirect electrical control, time and pressure dependent process controls
- Signal storage in the power and control units, latching circuit
- Documentation for a control unit
- Maintenance and repair of electropneumatic systems
- Solenoid actuated valves
- Double-acting cylinders
- Electrical buttons and switches
- Sensors
- Relays and contactors, timed relays
- Pressure switch
- Standardized circuit diagrams, electrical and pneumatic circuit diagrams

Single license with myleCampus
Online de/en/es/fr/fi/et/zh

Order no. **540923**

Hydraulics



Comprehensive hydraulics training. The program is divided into technical knowledge and coursework.

Technical knowledge

This interactive, self-guided program covers the basics of hydraulic control. Participants find practical and theoretical solutions to the key exercises in a basic course on hydraulics, e.g., as part of a basic vocational training course.

Course

In this course, the theory-based technical knowledge is reinforced. A wide range of exercise types makes the course interesting and successful. Participants have to draw symbols and circuit diagrams, answer multiple-choice questions, and set up and connect circuits in PC-based video clips.

From the table of contents:

- Physical basics (units, properties, laws)
- Hydraulic systems (principles of a hydraulic system)
- Drive units (components, pumps, containers, filters)
- Drives (single-acting cylinders, double-acting cylinders, hydraulic motors)
- Directional valves (design characteristics, 2/2 directional valves, 3/2 directional valves, 4/3 directional valves, special circuits)
- Stop valves (non-return valves, pilot operated non-return valves)
- Pressure control valves (pressure relief valves, pressure regulation valves)
- Flow control valves (throttle valves, flow control valves)
- Additional requirements

Single license with myleCampus
Online de/en/es/fr/fi/et/el/zh

Order no. **540917**

Electrohydraulics



The Electrohydraulics training program builds on the Hydraulics training program and reinforces material already learned from hands-on projects. Starting with concrete industrial applications, fundamental electrohydraulic circuits are produced. With the help of numerous exercises, learned material will be revised, applied, and further developed. During exercises, the program reacts to each answer with varying feedback.

The trainee is supported by the basic knowledge module, which provides fundamental knowledge on electrohydraulics in a structured, systematic manner. In the components module, the structure, functions and application of typical electrohydraulic components is described. Various supporting materials are available to complete the exercise such as PDF documents, a variety of downloads, and a comprehensive glossary.

From the table of contents:

- Advantages and drawbacks of electrohydraulics
- Safety in electrohydraulic circuits
- Fundamentals of electrical engineering
- Hydraulic circuit diagram
- Electrical circuit diagram
- Basic logic functions
- Direct and indirect electrical control, time and path-dependent process controls
- Signal storage in the power and control units, latching circuit
- Documentation for a control unit
- Maintenance and repair of electrohydraulic systems
- Solenoid actuated valves: spring return and pulse valves
- Double-acting cylinders
- Electrical buttons and switches
- Sensors
- Relays and contactors, timed relays
- Standardized circuit diagrams, electrical and hydraulic circuit diagrams
- Documentation of electrohydraulic controllers
- Simulation of a hydraulic and electrical circuit diagram

Single license with myleCampus
Online de/en/es/fr/fi/et/zh

Order no. **540929**

Multimedia training programs

Open- and closed-loop control

GRAFSET

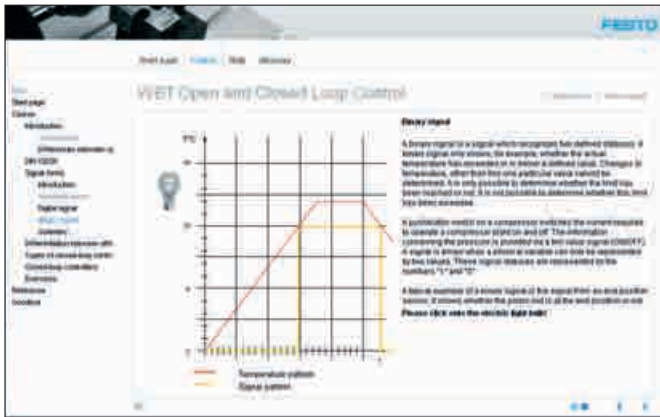

This training program uses practical examples to show the difference between open- and closed-loop control in automation. Easy-to-understand tasks are used first to examine the overall process of a simple functioning system. Later sections then look at different types of controllers, the different ways in which signals are represented and processed, and the ways in which programs are implemented.

- From the table of contents:
- Differences between open- and closed-loop control (characteristics of controllers, characteristics of regulators)
 - DIN 19226
 - Signal types
 - Differences between types of control
 - Signal processing (synchronous control, controlling links, asynchronous control, process control)
 - Types of control (regulating to fixed values, tracking values)
 - Regulators (P, I, and D controllers, combined controllers such as PI or PID controllers)

Single license with myleCampus
 Online de/en/es/fr/zh
 Order no. **540947**
 Network de/en/es/fr/zh
 Order no. **540949**



GRAFSET – The new specification language for sequential function charts

Good documentation is a prerequisite for the quick construction and smooth commissioning of a system. As a result, products reach customers more quickly. In addition, the sequence description is an important tool for quickly and accurately locating and eliminating errors, reducing production downtimes. GRAFCET can describe what the function chart has previously been unable to represent.

GRAFSET introduces the new standard step-by-step, with the aid of practice-related examples.

- From the table of contents:
- Definitions
 - Advantages of GRAFCET
 - Differentiation from PLC programming language
 - Configuring a GRAFCET
 - Graphical representation of the language elements
 - Graphical representation of the sequential structures
 - Structuring of GRAFCETS
 - Case studies
 - Exercises
 - Glossary

Single license with myleCampus
 Online de/en/es/fr/zh
 Order no. **557688**
 Network de/en/es/fr/zh
 Order no. **557689**

Our authoring tool:
Content Builder
 Devise and design your own training media
[→ www.festo-didactic.com](http://www.festo-didactic.com)

PLC programming in accordance with IEC 61131



Programmable logic controllers play a central role in automation. These devices are used to control machines and systems.

The program of a programmable logic controller can be flexibly adapted for any task. Various programming languages, which are all based on the IEC 61131 international standard, are available for creating the control program in compliance with standards.

This training program allows users to become familiar with function charts, ladder diagrams, instruction lists, sequential function charts, and structured texts in five programming languages. Through the use of various practice-related examples, the programming languages are presented step-by-step.

From the table of contents:

- Programmable logic controllers
- Project organization
- Programming languages in accordance with IEC 61131
- Link-orientated programming languages
- Sequential function chart
- Structured text
- Sequence programming project

The training program provides beginners with an ideal introduction to IEC-compliant programming.

In addition to trainees, and students, this program also appeals to skilled workers, technicians, and engineers who have previously only programmed in IL, LDR, or FCH. The higher, IEC-compliant languages provide a range of benefits to be discovered and used.

Single license with myleCampus

Online de/en/es

Order no. **574488**

Network de/en/es

Order no. **574489**

LOGO! Training



This training program provides an introduction to logic functions. First, AND & OR functions and processing are shown in function tables. Other basic control functions such as memory, timer and counter functions round off the topic coverage. The second part begins by covering the basics of open-and closed-loop control circuits and describes the elements of a controller. It then takes a detailed look at minicontrollers, including their features and areas of application.

From the table of contents:

- Basic technical functions (AND & OR function, memory function, timer function, counter function)
- Digital minicontrollers (differentiation between open- and closed-loop control)
- Control components
- Positioning with digital minicontrollers
- Design and function of a minicontroller
- Cyclical program processing
- Areas of application
- Programming languages

Single license with myleCampus

Online de/en/es/fr/zh

Order no. **540941**

Network de/en/es/fr/zh

Order no. **540943**

Our authoring tool:

Content Builder

Devise and design your own training media

→ www.festo-didactic.com

Courseware

Teaching materials for basic and advanced training



Theory and practice course range

A wide range of teaching materials for basic and advanced training are available for these topics.

- Pneumatics
- Hydraulics
- Electrical engineering/Electronics
- Automation/PLC
- Mechatronics/Process automation
- CNC technology/Equipment



Technical literature and textbooks

The technical literature and textbooks provide the basis for studying technologies and processes. For trainers and teachers, they are essential for preparing courses. They also provide anyone who does not enjoy self-study on a PC with professional guidelines for their practical exercises.



Workbooks

At the cutting edge for more than 50 years: Festo Didactic's training packages with equipment sets and tailored workbook with exercises and sample solutions (including CD-ROM). The exercises are based on industrial practice and have been successfully used in numerous courses for training specialist staff.



Dictionaries and manuals

Symbols, rules, standards, formulae etc. You don't need to have everything in your head, but you do need to know where to find it!



Legal security for you

Festo Didactic's teaching materials are already in widespread use for a diverse range of purposes. With the new licenses, the legal basis for your individualized use has now been established. From now on, you have the option of choosing one of three types of license, to ensure an optimized – and legally secure – use of Festo's teaching materials tailored to your needs.

You can choose from the following types of license:

HomeUse license

For personal use. The advantage to you: a lower price for the PDF of the training material.

Campus license

The standard option for commercial (professional) use. For all those wishing to use the training materials at a single location.

Enterprise license

For large (international) companies and educational institutions with multiple locations.

For information on each of the license types, please see the table below.

Note:

- The license types are valid for all Festo Didactic training materials.
- The full rights of use are set out in the legal information contained in the purchased training materials.

Properties	Campus license	Enterprise license
Scope of delivery	Teaching material (workbook with multimedia CD-ROM*)	As agreed
Document protection	–	–
Document can be modified	X	X
Reproduction rights	X	X
Multilingual version*	–	X*
Target group	Commercial/educational organizations (single location)	Commercial/educational organizations (multiple locations)
Shop	FESTO	FESTO

* The languages offered vary depending on the training material.

Hydraulics

Set of posters

Hydraulic symbols

Energy conversion: Symbols for pumps, motors, and accumulators.

Energy transfer: Symbols for hoses, filters, and heat exchangers.

Actuation: Symbols for solenoid valves, pilot-operated valves, and electrohydraulic relays.

Valves: Symbols for directional control valves, pressure-reducing valves, pressure-relieving valves, and check valves.

Pumps: Symbols for various types of hydraulic pumps.

Assessment: Symbols for pressure gauges, pressure sensors, and flow meters.

ISO 1219-1 and DIN EN 60924-2: Reference to the standards governing these symbols.

FESTO

Hydraulics – Structure of a hydraulic system

Signal control section: Shows the flow from a control energy supply through signal relays to the hydraulic power section.

Hydraulic power section: Shows the energy control section and energy supply section.

Power section: Shows the main hydraulic circuit with pumps, valves, and actuators.

Control section: Shows the control circuit with various control valves.

Legend: Provides a key for identifying components in the schematic, such as pumps, valves, and actuators.

FESTO

Hydraulics – Directional control and non-return valves

Directional control valves, directly actuated: 4/3-way and 6/3-way valves.

Directional control valves, pilot actuated: 4/3-way and 6/3-way valves.

Non-return valves: High-pressure and low-pressure types.

Non-return valves, pilot: Various pilot-operated designs.

FESTO

Hydraulics – Flow control and pressure control valves

Flow control valves: Throttle, orifice, and differential pressure types.

Pressure relief valves: Directly actuated and pilot-operated.

Pressure-reducing valves: Various designs for pressure regulation.

Flow control valves: 2-way and 3-way types.

Pressure control valves: 2-way and 3-way pressure regulators.

FESTO

Hydraulics – Energy supply and cylinders

Full-scale power pack: Shows the internal components of a hydraulic power pack, including the pump, filter, and reservoir.

Double-acting cylinder: Schematic diagram showing the cylinder's operation in both directions.

Single-acting cylinders: Schematic diagram showing the cylinder's operation in one direction.

Designs of cylinders: Lists various cylinder types and their applications.

Technical description	Design	Stroke length	Stroke speed	Stroke force	Stroke volume
Single-acting cylinder
Double-acting cylinder

FESTO

Everything that you need to know: Five posters on hydraulics

Now the updated version of the popular A1 poster is supplied rolled up, quickly providing a comprehensive overview. All symbols and terminology correspond to the current standards ISO 1219-1 and DIN/EN 81346-2.

Poster titles:

- Hydraulic symbols
- Hydraulics – Structure of a hydraulic system
- Hydraulics – Directional control and non-return valves
- Hydraulics – Flow control and pressure control valves
- Hydraulics – Energy supply and cylinders

de	196948
en	551012
es	551011
fr	551010

Pneumatics

Textbooks, Workbooks, Training material



Basic principles of pneumatics and electropneumatics

Textbook

- For use in vocational schools, technical colleges, schools for master craftspeople, and in company-wide training
- Conveys the essential basic principles of pneumatics and electropneumatics
- Contains technical and mathematical content, application examples, workflow descriptions, and safety measures for electropneumatic control systems, as well as overviews of the relevant symbols and circuit symbols
- Also presents in detail the design of circuit diagrams and individual pneumatic components
- Takes into account the change in the requirements and technical developments in electropneumatic control systems

F. Ebel, S. Idler, G. Prede, D. Scholz
3rd edition 2017, 211 pages, in color, bound.

de	567028
en	573030
es	573031
fr	573032

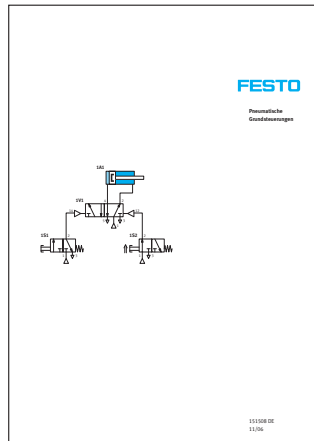

Basic pneumatic controllers

Practical knowledge
This booklet has been created for practitioners who need to implement small projects quickly and effectively. The various circuit examples facilitate the creation of many simple tasks. The examples shown are complementary. If something is not clear, the previous step can be referred to. This means that even those with little experience can quickly become familiar with the subject matter.

Reference work for circuit planning symbols

A detailed overview of the most important circuit planning symbols shows the structure of controllers and gives hints on the practical implementation of circuit diagrams that have been developed.

W. Braungard, P. Löbelenz, G. Mark
Edition 2006, 80 pages, booklet.

de 151508



Closed-loop pneumatics

Workbook

The 21 exercises contained in this workbook offer a practical introduction to closed-loop control pneumatics. Besides fundamentals, the workbook also covers subjects such as the function of various controllers and control circuits, empirical setting of controller parameters and the influence of interference variables. You will need equipment set Closed-loop control pneumatics, TP 111 to carry out the exercises.

The workbook includes:

- Sample solutions
- Training notes
- Multimedia CD-ROM with supplementary media
- Exercise sheets for trainees

J. Gerhartz, D. Scholz
Edition 2001, 542 pages, in folder.

Campus license (→ Page 19):

de	94459
en	94465
es	533499
fr	94347



Case of cutaway pneumatic models

For visualising the structure and function of pneumatic components.

All of the cutaway models used are of industrial design. Dynamic elements and wearing parts correspond to the original. The models selected are those relevant to pneumatic training. Some of the cutaway models retain their function or partial function so that they can be demonstrated in use.

The following components are included in a case of cutaway models:

- Single and double-acting cylinders
- Filter regulator
- AND gate
- OR gate
- Delay valve
- Quick-exhaust valve
- Valve slice
- Pressure gauge
- Roller lever valve
- Pressure sequence valve
- Pneumatic valve
- One-way flow control valve

Order no. 539007

Hydraulics

DVD, Textbooks



Fundamentals of hydraulics and electrohydraulics Textbook

This textbook teaches the main fundamentals of hydraulics and electrohydraulics in a clear manner:

- Physical fundamentals of hydraulics
- Fundamentals regarding hydraulic fluids
- Components of the power supply section
- Drives, pressure regulators, directional control valves, shut-off valves, flow control valves, and proportional valves, as well as characteristic values and designs
- Fundamentals of electrical engineering and electrical components
- Workflow descriptions for processing machines and production systems
- Circuit symbols and layout of circuit diagrams
- Safety measures for electrohydraulic control systems

Renate Aheimer, Christine Löffler, Dieter Merkle, Georg Prede, Klaus Rupp, Dieter Scholz, Burkhard Schrader

2012 edition, 232 pages, in color, bound.

de	574180
en	574181
es	574182



Proportional hydraulics, Basic level Textbook

How can speed be controlled? How is a position held? How is leakage avoided? Where and when can energy be conserved? This book provides a clear and easy-to-understand introduction to the fundamentals of proportional hydraulics.

D. Scholz

Edition 1997, 123 pages, bound.

de	94377
en	94378



DVD Electropneumatics/ Electrohydraulics, Basic level

This video primarily covers electrical controllers. In addition to an introduction to electrical engineering, it shows the most important switching elements and basic circuits. Practical applications alternate with animations and circuit examples.

The DVD is multilingual (de, en, es, fr, it, tr, cn, ru). The language can be selected.

48 minutes

Order no. 538487

Workstation systems





Universal laboratory furniture.....	26
Learnline	28
Learntop-S	36
Learntop-A/Learntop-L.....	38

The universal laboratory furniture

Learnline



The modular workstation systems for basic and specialized training. With many practical details to make teaching and learning easier.

With **Learnline**, you have an integrated storage principle that can be used for training in pneumatic, hydraulic, or electrical engineering without the need for modifications. Design and function are combined, which is evident in every practical detail. Learnline consists of basic mobile and stationary units with a cable/oil tray, various modular systems and extension elements, rolling and fixed containers, in addition to special storage systems, attachments, and the corresponding accessories. The modular workstation system offers a multitude of configurations and mounting options. Expert consultants in over 50 countries are available to prepare an individual quotation for you.

Quality from Festo

We don't make compromises when it comes to quality. Workmanship and functionality are of the highest level. The torsionally rigid design and the high-quality coating of the work surface and frame guarantee a long service life despite many stresses and strains. Learnline can handle the rigorous routine of everyday teaching as well as a vibrating load during hydraulic position control. Even high mechanical forces, e.g., of servo-hydraulics, proportional pneumatics, or robotic superstructures, can be easily accommodated by Learnline.

Versatile, flexible, and expandable

One glance at the basic structure proves that Learnline meets a multitude of requirements. After all, with just a few individual and well thought-out components, results can be achieved which suit the needs of people, the available space, and any technical challenges. The functional profile column is a prerequisite for modularity. As the central attachment point, it opens up a multitude of options for putting together each desired configuration.

All components can be placed anywhere on the slotted assembly board and can be fastened tightly and securely in the profile slot with a T-head nut or the patented Quick-Fix with little effort and without additional tools.

A mounting system for all technologies and applications.



Keeping order

It doesn't matter whether you keep your training packages in the Systainer or in the container. The storage equipment from Festo Didactic always ensures you have a quick overview. The lockable containers are equipped with self-closing drawer runners and a safety stop. Every drawer holds up to 20 kg (44 lb). The shipping packaging for the pneumatic and hydraulic equipment sets can be used as orderly drawer inserts. That saves material and gives you a quick overview of the drawer contents.

Integrated electrics

With various electrical insert panels, a supply duct, and different superstructures, workstations can be put to universal use. The mounting frames can be used for a large number of assembly boards and ER units. The ER mounting frame is compatible with the electrical components of the training packages. Alternatively, you can choose an A4 mounting frame according to the electrical engineering standard.



Standard for design and function

Learnline – Winner of international design awards:
 – iF product design award
 – Silver Focus design award

Learnline online configurator

Familiarize yourself with Learnline's functional design and configure your workstation quickly and easily on the Internet according to your individual requirements. Opt for a predefined standard workstation or put together your own configuration according to your needs. Slotted assembly boards, drawer units, and accessories can be easily selected and added to your configuration. The result is a graphic representation of your selection along with a parts list.

Learnline mobile

More versatile than ever!



Flexible and modular

Learnline is of modular design and offers an almost unlimited range of configuration possibilities for your Learnline workstation.

High mobility and optimum use of space

Individual or group training workstations can be created with a minimum of effort wherever they are required. Transport through doors is also possible. This mobile workstation is designed in such a way as to permit several people to work simultaneously. This is further facilitated by the two integrated, fixed drawer units that ensure quick and easy access to the required components of the Learning System.

Learnline
Winner of international design
awards





Optimum use of space

The positioning of the storage plate means that the free space beside the fixed drawer units can be used for Systainer or other storage systems. The hydraulic power unit with single pump fits conveniently beside the 1100 mm profile plate.



Hydraulics for advanced trainees

The double pump power unit fits neatly on the frame beside the fixed drawer units with no additional attachment required. The discharge measuring container also fits beside the 1100 mm profile plate.



Pneumatic and electrotechnical training

The storage plate can hold up to two compressors. Further mounting frames for electronic components in A4 format, for example, can be used in addition to the 700 mm profile plate.



Vertical or inclined?

Choose the vertical profile plate if you want to use the worktop for books or laptops, for example. Or if the workstation is to be used from both sides, opt for the inclination unit with an additional profile plate to adapt the plate inclination to your requirements.

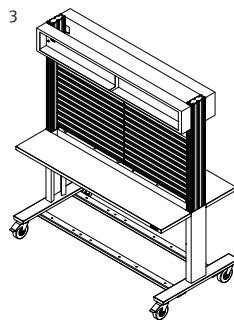
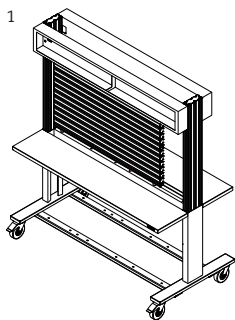

The preferred types with price advantage. Flexibly expandable.
(Overall dimensions W1556 x D780 x H1773)

1	With 1100 x 700 mm profile plate and ER frame	539028
2	With 700 x 700 mm profile plate and ER frame	539030
3	With 2x 700 x 700 mm profile plate and ER frame	572155

Stationary Learnline

Ergonomic and flexible



The stationary solution

With the stationary workstation systems, Learnline combines the requirements for typical desk systems with high functionality. They provide ample desk space and leg-room thanks to the roller container. The containers also ensure quick and easy access to any required components.

Vertical or inclined?

The sturdy profile plate is fastened to the stable profile of the angle adjustment. The inclination of the slotted profile plate can be infinitely adjusted, all the way down to a horizontal position. The workstation arrangement thus always offers the best ergonomic position for any exercise.

Learnline
Winner of international design prizes





**Move up into another dimension:
profile columns as set-up space**

Use the versatile profile columns as a set-up space, compatible with Quick-Fix, for equipment sets or for attaching additional components vertically. Additional components, for example cylinders with a 400 mm stroke, can be mounted on the angle adjustment profile.

Optimum space utilization

Thanks to the angle adjustment, the profile plate can be lowered into a horizontal position. Use the available space for A4 or ER mounting frames.

Pneumatic and electrical training

In addition to the 700 mm (27.5") profile plate, additional mounting frames can be inserted for electronic components.

Ergonomic connections

With the supply duct, all important interfaces are within reach. In addition to the electrical and pneumatic supplies, PC interfaces, such as USB, Ethernet, or serial interfaces, can also be integrated in the supply duct.

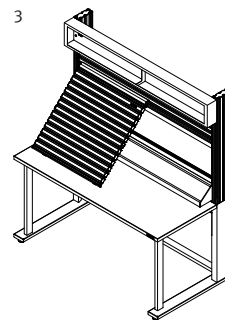
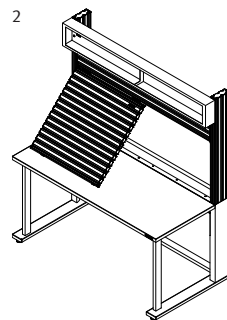
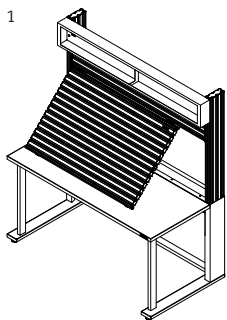

The preferred types with price advantage. Flexibly expandable.
(Overall dimensions W1512 x D780 x H1718)

1 With 1100 x 700 mm profile plate and ER frame	539023
2 With 700 x 700 mm profile plate and ER frame	539025
3 Order no. 539025 with supply duct	On request

Your individual design

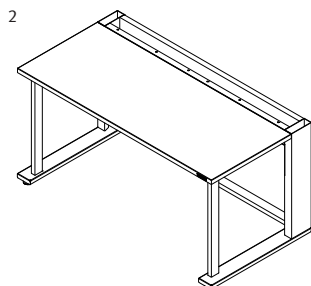
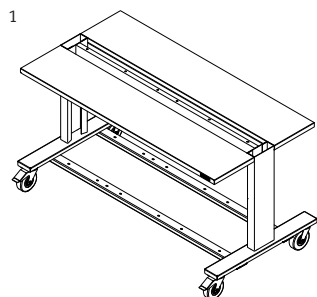

Basic units

Stable and with a high-quality coating, the basic worktables are guaranteed to fulfill your high requirements.

1 Basic mobile unit

With castors and wheel brakes. The high worktop ensures a comfortable working position when standing. The flexible design of this workstation makes it ideally suited to simultaneous use from both sides. W 1556 x D 780 x H 815.

2 Basic stationary unit

The height of the worktop ensures a comfortable working position when seated. For holding a mounting frame for profile plate set-up. W 1512 x D 780 x H 760.

1 Basic mobile unit	535832
2 Basic stationary unit	535835

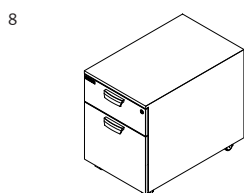
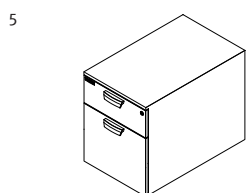
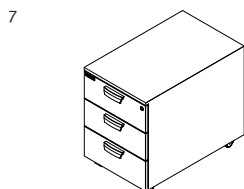
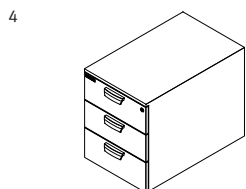
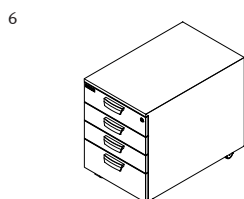
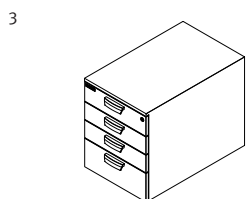

Drawer units

3/4/5 Fixed drawer unit for installation in mobile workstations

Drawer unit with fully-extending, lockable steel drawers with safety stop. Fronts can be labelled. Load 20 kg per drawer. External dimensions of body W 476 x D 788 x H 592, usable inner dimensions W 375 x D 700.

6/7/8 Wheeled drawer unit for stationary workstations

Wheeled drawer unit with fully extending, lockable steel drawers with safety stop. Fronts can be labelled. Load 20 kg per drawer. External dimensions body W 476 x D 788 x H 657, usable inner dimensions W 375 x D 700. All wheels freely movable, two wheels with lockable brake.

3 Fixed drawer unit for pneumatics (4 drawers)	535833
4 Fixed drawer unit for hydraulics (3 drawers)	539026
5 Fixed drawer unit for mobile hydraulics (2 drawers)	574153
6 Wheeled drawer unit for pneumatics (4 drawers)	535834
7 Wheeled drawer unit for hydraulics (3 drawers)	539731
8 Wheeled drawer unit for mobile hydraulics (2 drawers)	574152

Mounting frame/Mounting sets

Versatile profile columns form the core of the Learnline system. They are used to mount the profile plate frame, to attach components, or as an alternative mounting surface for your training components.

1 For vertical mounting of the profile plate

The profile plate support is mounted between the profile columns, the profile plate is securely screwed to the mounting frame and the frame structure. This makes the workstation extremely strong and resilient and means that the profile plate can be used from both sides.

2 For inclined mounting of the profile plate

The profile plate support can be mounted at any height between the two profile columns, ensuring workstation ergonomics tailored to your requirements. You can also place the components from the training package directly on the mounting frame, thereby freeing up additional workspace.

3 Mounting frame/Mounting sets for A4 mounting frame

A4 mountings are mounted between the profile columns. Up to three rows of A4 mountings can be attached by means of two additional mounting sets for A4 mounting.

When mounting profile plates, order one mounting set per profile plate.
When mounting A4 units, order one mounting set for A4 mounting for each additional row.

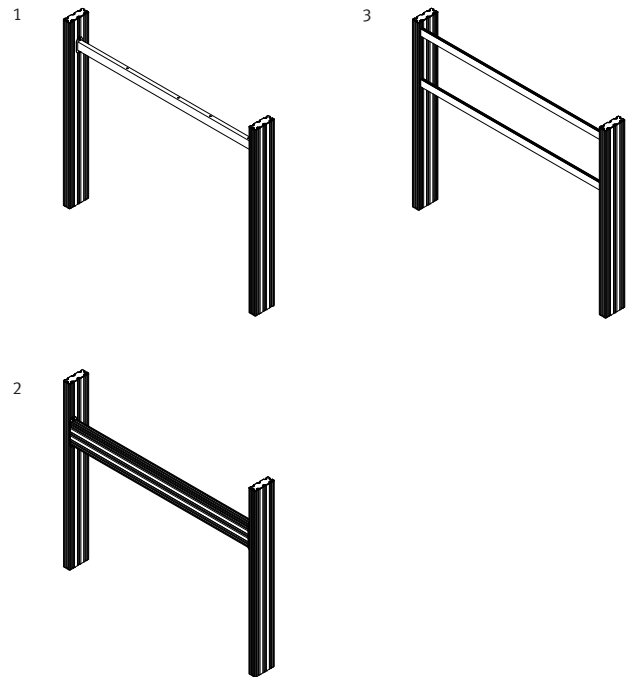

1 Mounting frame for vertical mounting of the profile plate	540698
Mounting set for vertical mounting of the profile plate	540697
2 Mounting frame for inclined mounting of the profile plate	539032
Mounting set for inclined mounting of the profile plate	539735
3 Mounting frame for A4 mounting frame	8066141
Mounting set for A4 mounting frame	8065498

4/5 Aluminum profile plates

The anodized aluminum profile plate forms the basis for all training packages. All of the components fit securely and safely into the grooves on the profile plate. There are grooves on each side and, if required, both sides can be

fitted with components.

The grooves are compatible with the ITEM profile system. Grid dimensions: 50 mm (1.97”).

For installation on tables we recommend the appropriate rubber feet

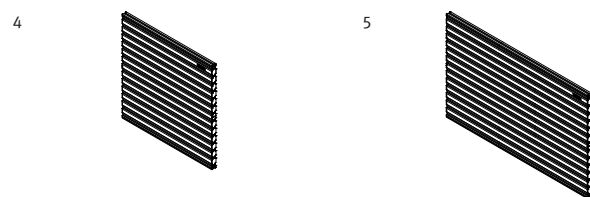

700 x 550 mm	159409
4 700 x 700 mm	159410
5 700 x 1100 mm	159411

Your individual design

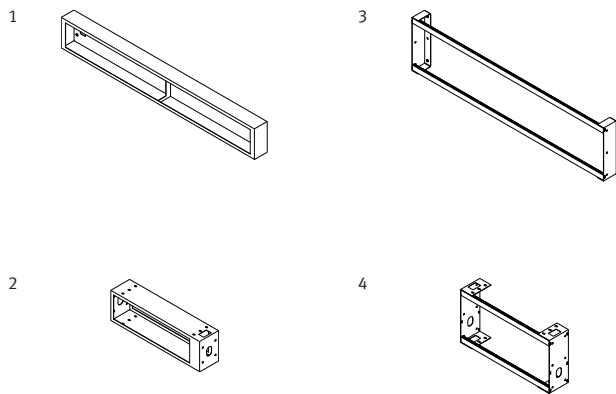

ER and DIN A4 mounting frames

The mounting frames for the workstations are designed to hold a large number of exercise boards and ER units from the Learning System for Automation. This compatibility also extends to electrotechnical equipment in A4 format. It is thus possible to obtain a satisfactory solution to almost any specific task.

1/3 Mounting frame (1500 mm wide)

The frame mounted on the profile column is height-adjustable and holds up to 12 ER/6 A4 units. One mounting frame can be attached to each side of the mobile workstation.

2/4 Mounting frame (700 mm wide)

The small mounting frame permits the use of ER/A4 components to the direct left or right of a 700 mm broad profile plate.

1 ER mounting frame (1500 mm wide)	539022
2 ER mounting frame (700 mm wide)	539033
3 A4 mounting frame (1500 mm wide)	539021
4 A4 mounting frame (700 mm wide)	539755

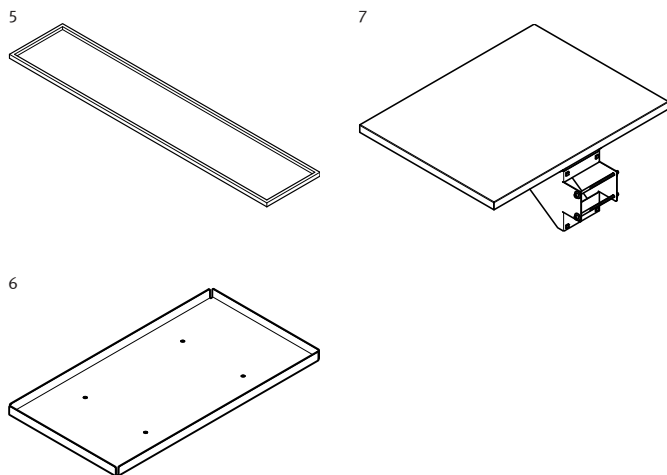

5 Oil spillage/protective mat

Black, with rubber border. Protects the tabletop of the Learnline system and keeps it clean.

312 x 1512 mm	541133
---------------	--------

7 Table extension

For easy attachment to the profile column of a mobile workstation. The height of the table can be adjusted to between 700 and 815 mm. The tabletop dimensions are W 780 x D 600.

Order no.	566435
-----------	--------

6 Storage plate

Fits into the mobile frame, in addition to two drawer units, and offers installation space for two compressors (order no. 91030) for example. W 748 x D 403 x H 30.

Order no.	539729
-----------	--------

Accessories

1 Universal bracket

Permits the mounting of up to two hydraulic power units with single pump, up to two hydraulic measuring containers, or holders for storing hoses.

W 50 x D 275 x H 130.

Order no. **539736**

2 Hose holder

For up to 20 hydraulic hoses. Provides neat storage and protects hose couplings from ingress of dirt.

W 366 x D 182 x H 80.

Order no. **539737**

3 Cable guide

For a set of laboratory cables. Ensures that cables are kept neatly and in order.

W 150 x D 136 x H 63.

Order no. **535812**

4 Monitor bracket, short

Monitor bracket for TFT and LCD monitors with drill holes in accordance with the VESA standard (distance between holes 75 x 75 mm or 100 x 100 mm).

- Short swivel arm for minimum distance to the mounting surface (approx. 8 cm)
- For mounting on Learnline mounting frames or fastening to a wall
- Rotatable up to 180°, tiltable up to 45°
- Supplied complete with mounting material
- Maximum load capacity 23 kg

Order no. **556292**

5 Monitor bracket, long

Monitor bracket for TFT and LCD monitors with drill holes in accordance with the VESA standard (distance between holes 75 x 75 mm or 100 x 100 mm)

- Long, telescopic, articulated arm for a large swivel angle
- Distance from mounting surface (approx. 8 – 38 cm)
- For mounting on Learnline mounting frames or fastening to a wall
- Rotatable up to 180°, tiltable up to 45°
- Supplied complete with mounting material
- Maximum load capacity 15 kg

Order no. **556293**

6/7/8 Protective grounding for workbenches

The products serve as protective grounding for workbenches as per the VDE 0100 standard. This is achieved by connecting accessible, conductive parts to each other by means of equipotential bonding conductors and by connecting all this to the PE conductor of the power supply.

6 Grounding kit

A grounding kit is required for connecting all conductive parts of one to two workbenches. The connector for the PE conductor of the power supply is included.

Order no. **8049368**

7 Connection kit

A connection kit is required for connecting a workbench to the PE conductor of the power supply.

Order no. **8049447**

8 T connector for PE conductors

A T connector lets you combine up to three PE conductors for connection to the power supply.

Order no. **8049442**

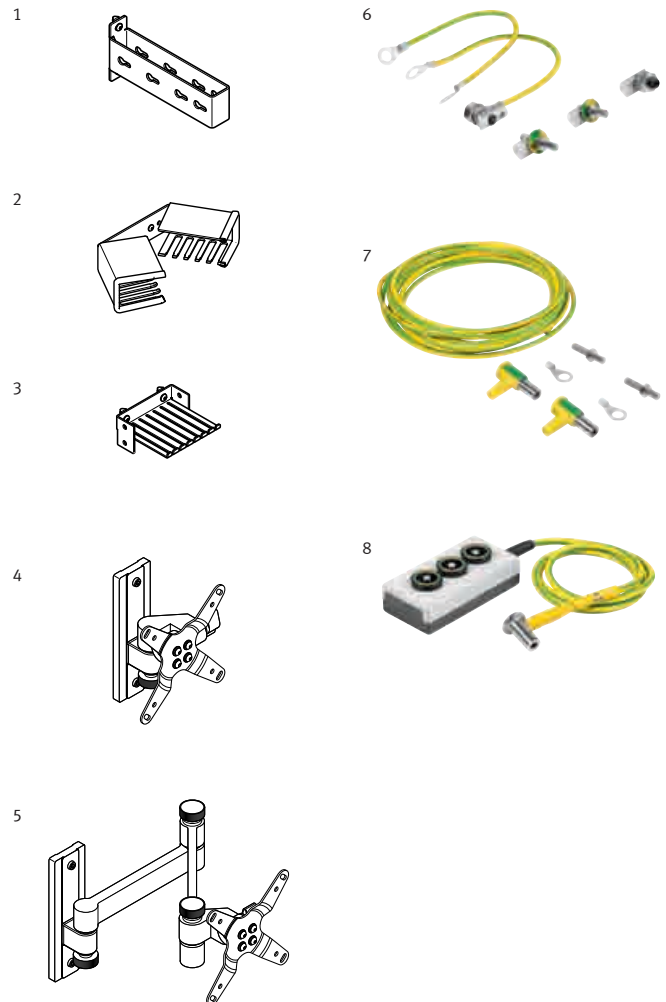

Learntop

The low-cost desktop mounting system



The low-cost introduction to the world of training packages from Festo Didactic: Enjoy the advantages of the profile plate and the ER mounting frame when carrying out your pneumatic, hydraulic, sensor, or PLC training. The devices can be clearly arranged and ensure an ergonomic working position at your existing work tables and benches.

Mounting parts and instructions for mounting the profile plates are included. It is recommended that Learntop be fastened to the table for security reasons.

1 Learntop-S

The versatile equipment holder for all technologies.

- Mobile: Can be simply set up on an existing work table/bench.
- Versatile: Can be used from both sides.
- Ergonomic: The angled profile plate enables components to be easily assembled.
- Dimensions (W x H x D): 1110 x 525 x 980 mm

Accepts up to four profile plates of size 350 x 1100 mm (order no. 162360) or two profile plates 700 x 1100 mm (order no. 159411).

Accepts up to two profile plates of size 350 x 1100 mm (order no. 162360) and two slotted mounting plates for Learntop-S for mounting Quick-Fix clamping components, one on each side.

Profile plates not included.

Order no. **8062672**



2 Mobile worktable for Learntop-S

- Drawer unit with eight fully extending drawers. Load up to 20 kg per drawer
- Storage space with lockable sliding doors
- Steel tub table top
- Dimensions (W x H x D): 1118 x 920 x 778 mm
- Table top height: 920 mm

Order no. **8062673**



Learntop-S

Accessories

1 Aluminum profile plate

The anodized aluminum profile plate forms the basis for all training packages. All of the components fit securely and safely into the grooves on the profile plate. There are grooves on each side and, if required, both sides can be fitted with components. The grooves are compatible with the ITEM profile system. Grid dimensions: 50 mm.

For installation on tables we recommend the appropriate rubber feet (order no. 158343).

Size 350 x 1100 mm supplied without side caps (H x W).

350 x 1100 mm	162360
700 x 1100 mm	159411

2 Perforated work surface

For Lab-Volt Series Pneumatics/ Hydraulics Training System, 700 mm x 1100 mm for Learntop-S. (Only compatible with Learntop-S)

Order no. **8062675**

3 Slotted mounting plate

For mounting Quick-Fix clamping components. Must be used together with an Aluminum profile plate 350 mm x 1100 mm (order no. 162360) to hold Quick-Fix screw components as well. (Only compatible with Learntop-S order no. 8022672)

Order no. **8062676**

4 Cable guide

For a set of laboratory cables. Ensures that cables are kept neatly and in order. W 150 x D 136 x H 63.

Order no. **535812**

5 Hose holder

For up to 20 hydraulic hoses. Provides neat storage and protects hose couplings from ingress of dirt. W 366 x D 182 x H 80.

Order no. **539737**

6 Steel tub base for Learntop-S

Order no. **8062674**

7 Mounting kit for hydraulic cylinder with weight

To be mounted on Learnline with a vertical or horizontal profile plate (alternatively for mounting on the Learnline profile column) or Learntop-S with an inclined profile plate. With this mounting kit, the pulling and pushing load of the basic hydraulics packages, which comprise the cylinder (order no. 152857) and weight (order no. 152972), can be achieved. The cover (order no. 152973) must be used for safety reasons.

Learntop-S, inclined profile plate

Order no. **526847**

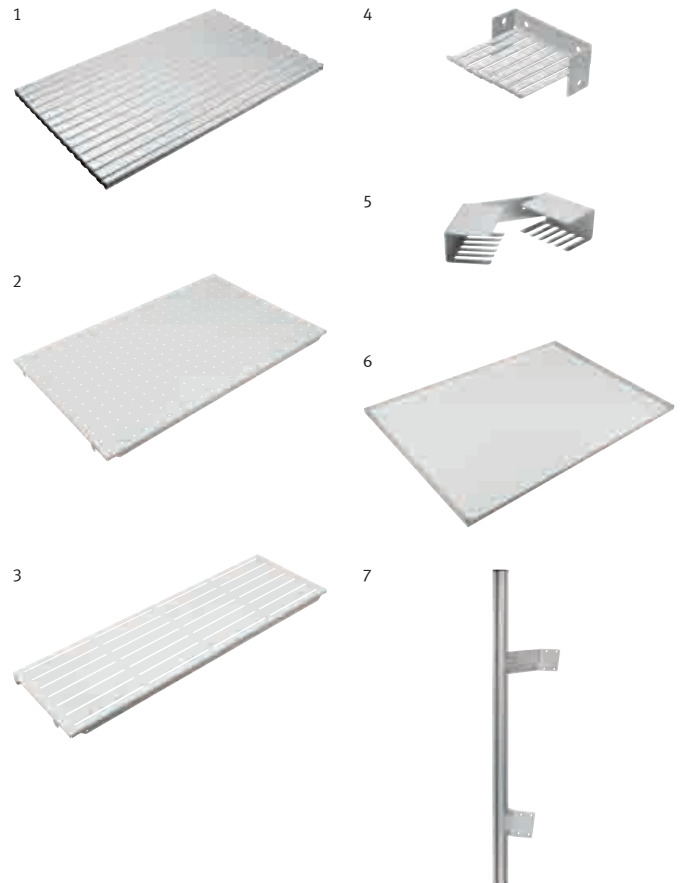

Learntop-A/Learntop-L

The low-cost desktop mounting system

1

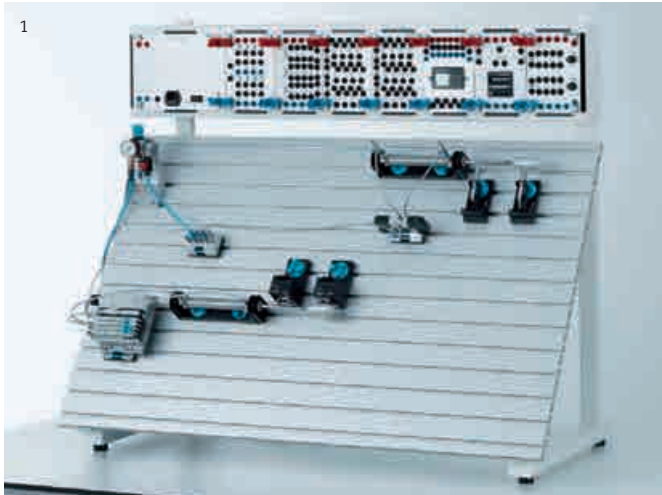

The low-cost introduction to the world of training packages from Festo Didactic: Enjoy the advantages of the profile plate and the ER mounting frame when carrying out your pneumatic, hydraulic, sensor, or PLC training. The devices can be clearly arranged and ensure an ergonomic working position at your existing work tables and benches.

Mounting parts and instructions for mounting the profile plates are included. It is recommended that Learntop be fastened to the table for security reasons.

1 Learntop-A

Equipment holder for use on one side of the workstation. Inclined profile plate allows ergonomic arrangement of components. Not suitable for hydraulic training.

Can hold up to two profile plates of size 350 x 1100 mm (order no. 162360) or one profile plate of size 700 x 1100 mm (order no. 159411).

Profile plates not included.

Order no. **540670**

2 Learntop-L

Equipment holder for use on one side of a workstation; for profile plates of size 700 x 1100 mm (order no. 159411). For horizontal profile plate configurations. Not suitable for hydraulic training.

Profile plates not included.

Order no. **540669**

2



Learntop-A/Learntop-L

Accessories

1 Aluminum profile plate

The anodized aluminum profile plate forms the basis for all training packages. All of the components fit securely and safely into the grooves on the profile plate. There are grooves on each side and, if required, both sides can be fitted with components. The grooves are compatible with the ITEM profile system. Grid dimensions: 50 mm.

For installation on tables we recommend the appropriate rubber feet (order no. 158343).

Size 350 x 1100 mm supplied without side caps (H x W).

350 x 1100 mm	162360
700 x 1100 mm	159411

2 Mounting kit for hydraulic cylinder with weight

To be mounted on Learnline with a vertical or horizontal profile plate (alternatively for mounting on the Learnline profile column) or Learntop-S with an inclined profile plate. With this mounting kit, the pulling and pushing load of the basic hydraulics packages, which comprise the cylinder (order no. 152857) and weight (order no. 152972), can be achieved. The cover (order no. 152973) must be used for safety reasons (similar to illustration).

Learnline, vertical profile plate

Order no.	533528
-----------	--------

Horizontal profile plate (e.g. Learntop-L)

Order no.	119352
-----------	--------

3 Slotted mounting plate

All components with the Quick-Fix mounting system can be mounted on slotted mounting plates. The slotted mounting plates are fitted with elastic buffers and can be used horizontally on a table top. Order no. 159331 can also be inserted in conventional A4 mounting frames. The slotted mounting plates are not intended for use with actuators. (overall dimensions B x H)

694 x 297 mm	159331
700 x 550 mm	544246

4 Rubber feet

For non-slip, protective mounting of profile plates on tabletops of any type. Set (four pieces).

Order no.	158343
-----------	--------

5 Plug-in adapter set

The plug-in adapter set can be used to mount the ER units directly on the blue plug-in board or on the aluminum profile plate. One set is required to mount one unit.

Order no.	541122
-----------	--------

6 A4 ER mounting frame

The ER mounting plate can be installed in any A4 mounting frame. A cut-out permits installation of two large or four small Festo Didactic ER units (H x W).

297 x 500 mm	536200
--------------	--------

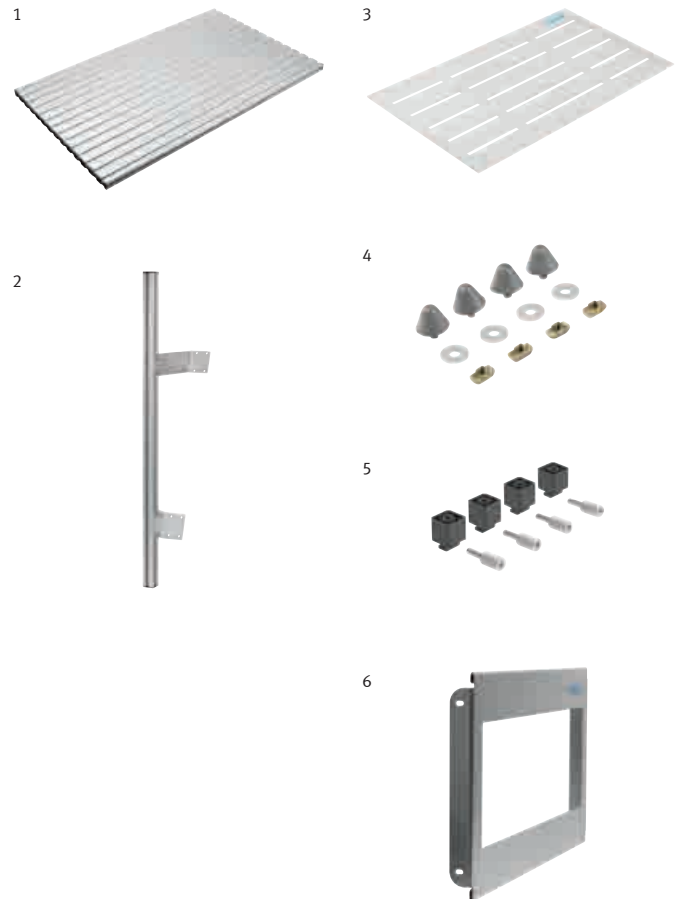

Pneumatic/Hydraulic training packages





Overview Pneumatics/Hydraulics training packages.....42

Pneumatics

System description46
Pneumatics48
Electropneumatics56
Measurement and control64
Drives.....66
Vacuum68
Sensors70
Safety.....72
Digitalization in pneumatics.....74
BIBB pneumatics76
BIBB electropneumatics.....78
Closed-loop pneumatics79
Energy-efficient compressed air management80
Sensors/PLC82

Hydraulics

System description84
Hydraulics86
Electrohydraulics94
Measurement and control102
Proportional hydraulics.....104
Closed-loop hydraulics.....108
BIBB hydraulics.....110
Mobile hydraulics.....111

Pneumatics training packages

Overview and structure

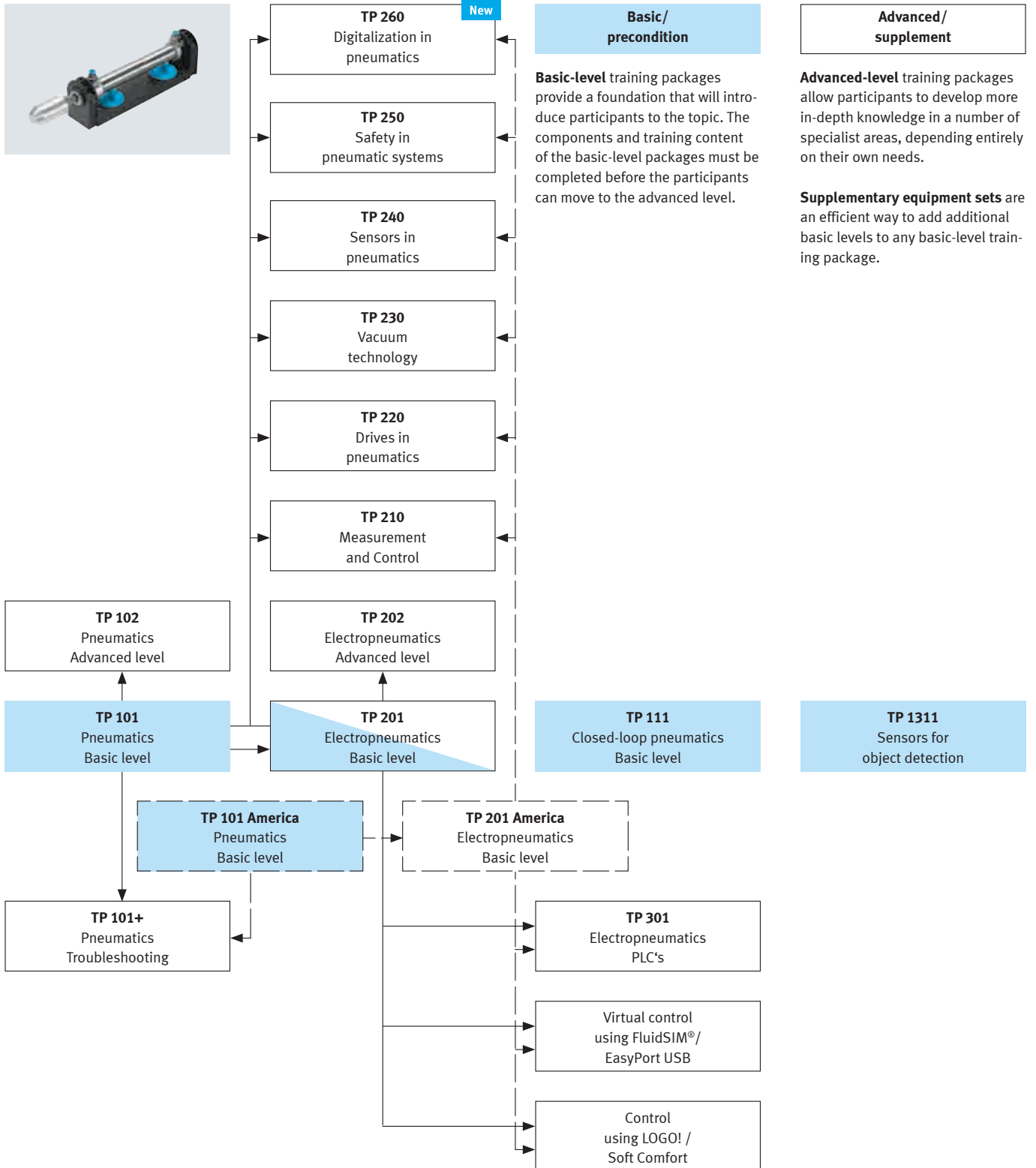

Hydraulic training packages

Overview and structure



Basic/ precondition

Basic-level training packages provide a foundation that will introduce participants to the topic. The components and training content of the basic-level packages must be completed before the participants can move to the advanced level.

Advanced/ supplement

Advanced-level training packages allow participants to develop more in-depth knowledge in a number of specialist areas, depending entirely on their own needs.

Supplementary equipment sets are an efficient way to add additional basic levels to any basic-level training package.

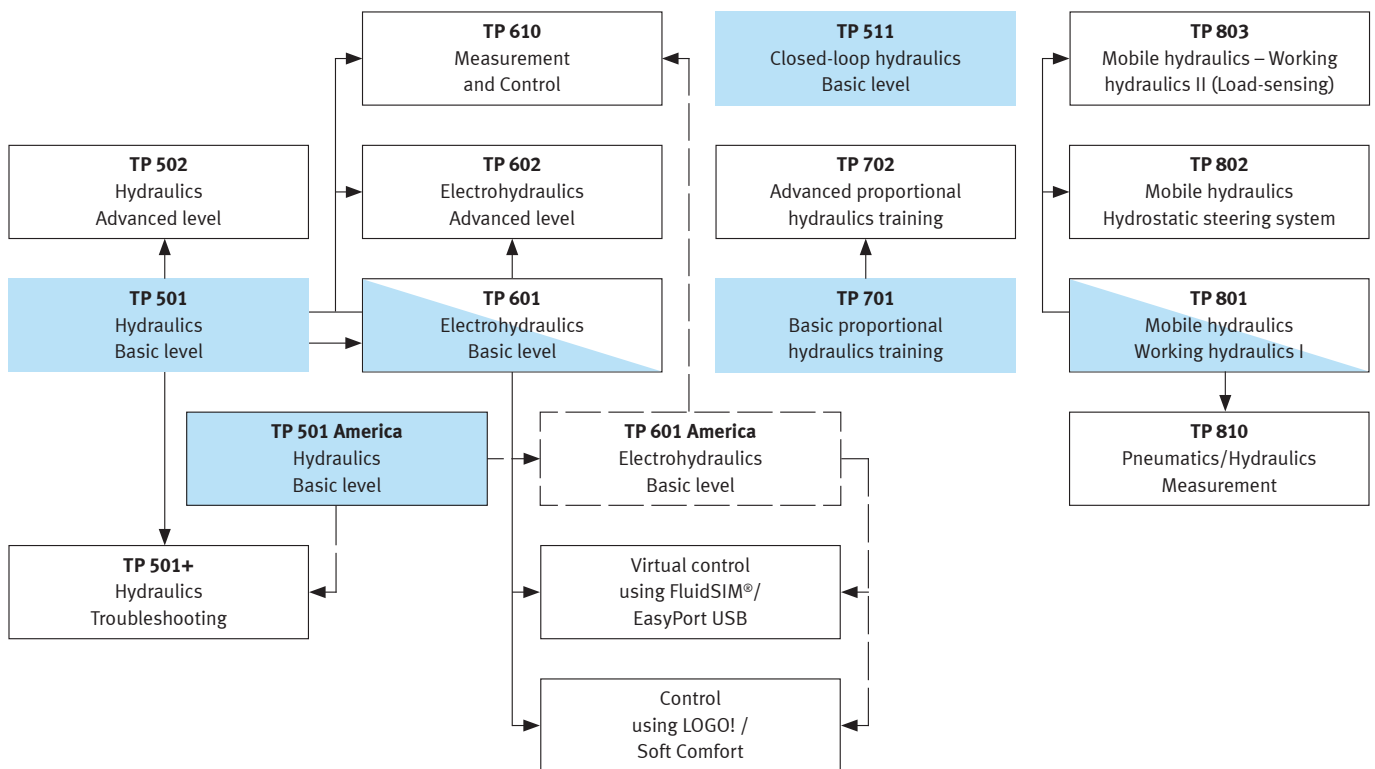

Transition from LabVolt ...

Pneumatic and Hydraulic training packages

Hydraulics
Training System

Pneumatics
Training System

Sensors

Sensors
6085

Advanced

**Servo Control of
Hydraulic System 6080-4**

Add-On to Electrical Control

**Servo Control of
Pneumatic System 6081-4**

Add-On to Electrical Control

Basic

PLC
6082

Electrical Control
6080-2

Add-On to Fundamentals

Electrical Control
6081-2

Add-On to Fundamentals

Troubleshooting
Hydraulic Circuits
6080-F

Add-On to Fundamentals

Fundamentals
6080-1

Basic System

Fundamentals
6081-1

Basic System

Troubleshooting
Pneumatics Circuits
6081-F

Add-On to Fundamentals



... to Festo Didactic Series

Hydraulics
Training Packages

Pneumatics
Training Packages



Sensors for object detection
TP 1311



Closed-loop Hydraulics
TP 511

Closed-loop Pneumatics
TP 111



Control Kit FluidSIM®
EasyPort USB

Control Kit LOGO!
Soft Comfort

Electrohydraulics
TP 601 America

Electropneumatics
TP 201 America

Troubleshooting
TP 501+

Basic Hydraulics
TP 501 America

Basic Pneumatics
TP 101 America

Troubleshooting
TP 101+



Pneumatics training packages

Innovative and practical, right down to the smallest details



Modular for flexible expansion

Festo Didactic's training packages are modular in structure. For example, you could start with the basic level of electropneumatics and then move onto the advanced level, or start with the subject of electrohydraulics – the choice is yours. You'd like to explore a particular specialized topic? All equipment set components can also be ordered separately, so you can turn your own ideas into reality.



Position it – clamp it – done!

With the Quick-Fix mounting system, you can mount all components easily and securely on the profile plate and the profile column of a Learn-line workstation. The electrical units are clamped into the ER frame and sequenced individually. The profile slots on the workstations are the same for all pneumatic, hydraulic and electrical units – a single investment, with double the functionality.



Everything where you want it – systematic storage

Most equipment sets are delivered in practical, Systainer-compatible equipment trays. This equipment tray fits in the drawers of the workstations. The large pictogram on the components, designed in accordance with the latest standards, provides clear instructions for connecting the components and ensures short preparation and follow-up times. When dismantling circuits, you can quickly and easily locate where the component goes in the equipment tray.



Connect it – power!

No compromise on safety: all electrical components and units are connected with 4 mm safety sockets or safety plugs. The pneumatic power is supplied by the connection of highly flexible plastic tubing to the Quick Star (QS) push-in fitting. The system therefore requires virtually no consumables or tools.



Didactic plus

The workbooks accompanying the training packages contain project-oriented exercises of increasing complexity. There are also positional sketches, illustrations, videos, animations, and cross-sectional drawings, which explain how things look in the real world. For a complete and expert treatment of the topic of pneumatics, the training also covers basic physics, technical calculations, safety, economic efficiency, analytical fault-finding, and professional documentation.



Practical basic and specialized training using industrial components provides the confidence to apply the acquired knowledge in the workplace. The components are specially selected for the exercises in the workbook. Note: nearly all pneumatic and electrical connections are located on the easily accessible upper side of the components.



Your choice of training environment

User-friendly training environments for specific topic areas:

- Self-study phases with the training programs
- Designing and documentation with FluidSIM®
- Hands-on experimentation with the training packages and the exercises in the workbooks
- Functional testing and optimization with measurement technology and FluidLab®



Advanced courses made easy

New developments and trends in fluid engineering can be incorporated directly into our learning systems. New control systems can be integrated into the learning system using the EduTrainer® concept. Basic packages can be easily expanded to include the subjects "Pneumatics measurement and control TP 210" or the new "Vacuum technology TP 230."



TP 230 Vacuum technology

Manipulating workpieces with suction grippers has become an indispensable part of handling technology. It offers advantages, such as the simple configuration of suction grippers and gentle handling of workpieces, while also enabling rapid cycle times, and the capital outlay required is comparatively low. The training package TP 230 expands the contents of TP 201 to include the key area of vacuum technology.



TP 250 Safety in pneumatic systems

Function, efficiency, and above all safety determine the success of plant machinery and automated systems. New directives and laws require intelligent solutions and raise the level of professional skills required. The systematic optimization of a simple pneumatic system helps to identify hazards in pneumatic processes. The appropriate actions to reduce the risk can be implemented in a professional manner.

Equipment set TP 101 – Basic level

Basic pneumatics training

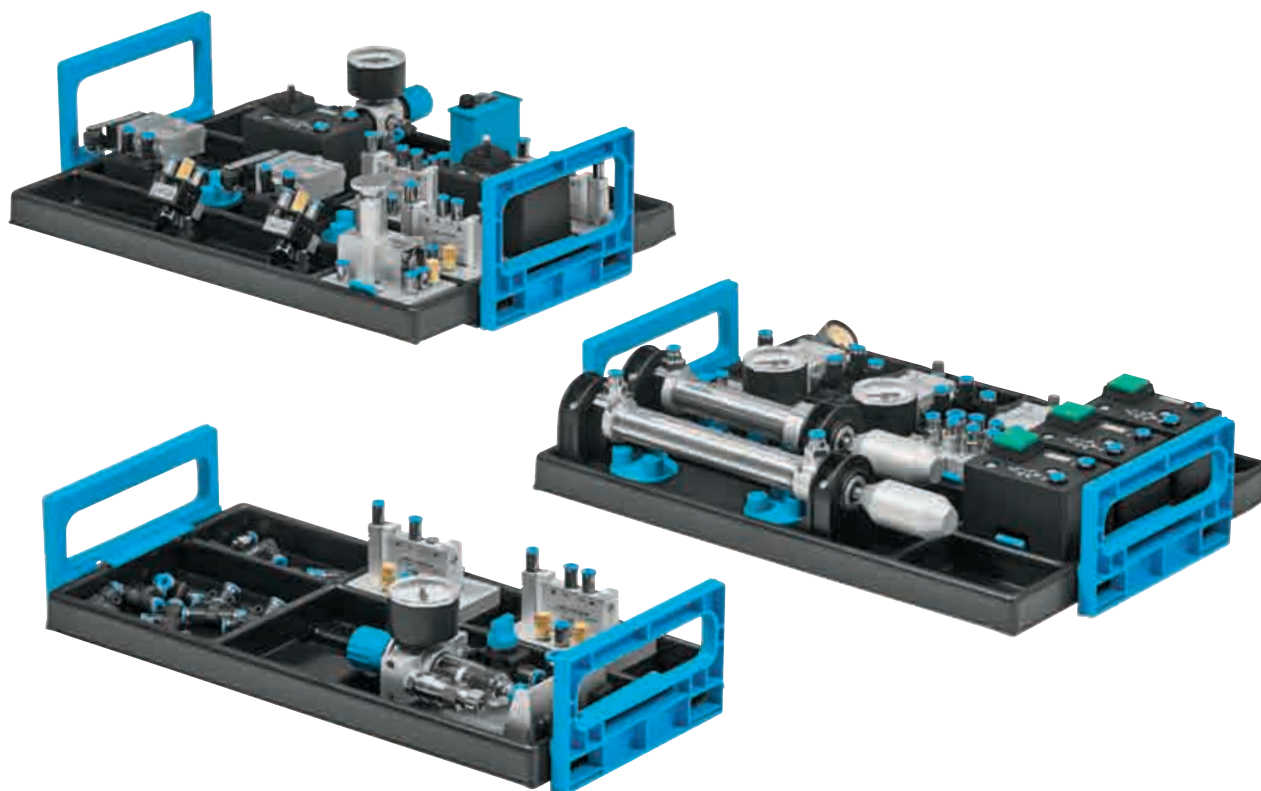

Pneumatics, Basic level – The fully revised classic

Further enhanced and updated according to the lessons learned from over 1,000 seminars on pneumatics.

- Brand-new components enable you to teach tomorrow's industrial standard today.
- The workbook contains a series of progressively complex project exercises based on actual industrial applications, an enhanced section on fundamentals, and a multimedia CD-ROM.

The number of components and the design are specially tailored to the projects contained in the workbook so that the main fundamentals can be imparted with little outlay. Delivered in practical, Systainer-compatible equipment trays.

Training aims

- Structure, function, and application of single-acting and double-acting cylinders
- Calculating basic parameters
- Direct and indirect actuation
- Application and function of 3/2 and 5/2-way valves
- Methods of actuation of directional control valves
- Analyzing circuits
- Options for pressure measurement
- Pressure-dependent control systems
- Distinguishing flow control methods and applying them appropriately
- Explaining and building latching circuits
- Logic operations: explaining and implementing AND/OR/NOT operations
- Combining logic operations
- Function and application of limit switches
- Time delay valves
- Realizing oscillating movement
- Economic considerations of using pneumatic components

Performance through close proximity

For optimum performance, switches and valves should be mounted as close to the actuator as possible. With the addition of new components, you can now apply the same principle when designing your circuits. This approach also provides you with an easy way of demonstrating the performance of a one-way flow control valve. You can even record the measured values and analyze the results, for example, using the TP 210!

The next generation of valves

The new generation of valves allows the operation of various pressure zones – so nothing stands in the way of an efficient use of energy. In addition, the position of connection was optimized so that differences between the circuit symbol and the valve can be avoided.

Pneumatic timer

The easy-to-read pneumatic timer can be precisely adjusted. Pressure changes do not alter the set delay time. Pneumatics at its best.

Complete equipment set TP 101 in equipment tray 540710

The most important components at a glance :

1	2x 3/2-way valve with pushbutton actuator, normally closed	152860
2	1x 3/2-way valve with pushbutton actuator, normally open	152861
3	1x 5/2-way valve with selector switch	152862
4	1x 3/2-way valve with selector switch, normally closed	152863
5	2x 3/2-way roller lever valve, normally closed	152866
6	2x Proximity sensor, pneumatic, with cylinder attachment	2764815
7	1x Pneumatic timer, normally closed	540694
8	1x Pressure sequence valve	152884
9	1x 3/2-way valve, pneumatically actuated at one end	576302
10	1x 5/2-way valve, pneumatically actuated at one end	576307
11	3x 5/2-way double pilot valve, pneumatically actuated at both ends	576303
12	1x Shuttle valve (OR)	539771
13	2x Dual-pressure valve (AND)	539770
14	1x Quick-exhaust valve	539772
15	2x One-way flow control valve	193967
16	1x Single-acting cylinder	152887
17	1x Double-acting cylinder	152888
18	1x Start-up valve with filter control valve	540691
19	1x Pressure regulator valve with gauge	539756
20	2x Pressure gauge	152865
21	1x Manifold	152896
22	2x Plastic tubing, 4 x 0.75 silver 10 m	151496

Accessories, also order:

Aluminum profile plate → Page 39

Compressor → Page 136

Also order:

Workbook



Nineteen project-orientated exercises, increasing in complexity and suitable for equipment set TP 101, are the ideal introduction to pneumatics. Real problem descriptions with positional sketch, concrete project tasks, and detailed aids for professional implementation provide the ideal preparation for the real-life industrial environment.

The workbook includes:

- Sample solutions
- Training notes
- Multimedia CD-ROM with graphics, photos of industrial applications, animations, and FluidSIM® circuit diagrams
- Exercise sheets for trainees

Campus license (→ Page 19):

de	540671
en	541088
es	542503
fr	542507

Supplementary media

- Design and simulation using FluidSIM®
- WBT Pneumatics
- Textbook: Basic principles of pneumatics and electropneumatics
- Cutaway model case

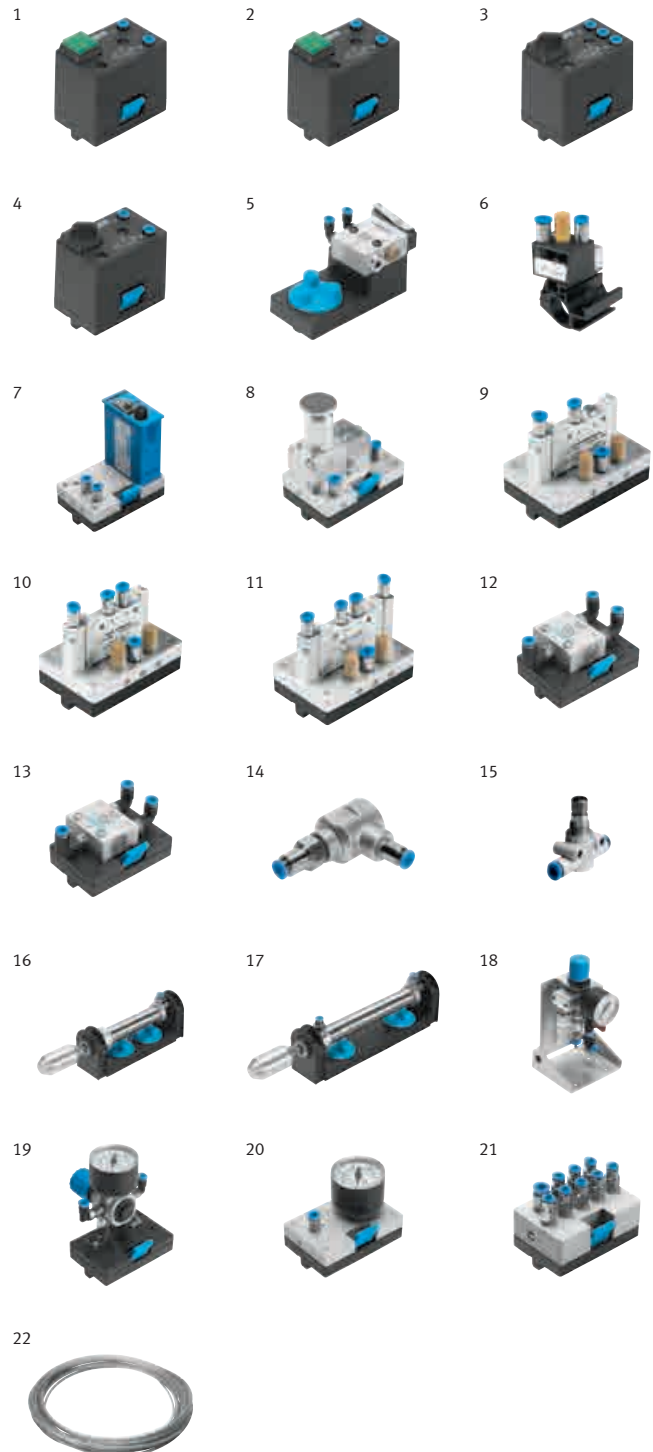

Equipment set TP 101+ – Advanced level

Systematic troubleshooting

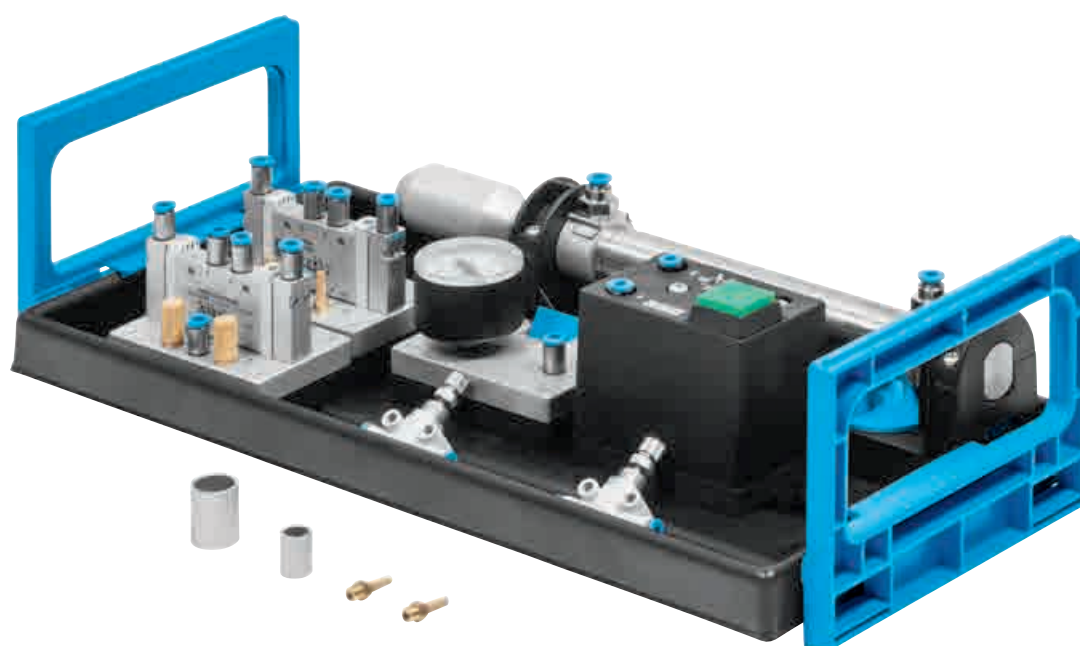

Realistic

Equipment set TP 101+ from Festo Didactic is an extension to equipment set TP 101. TP 101+ contains components with specified, realistic defects. It enables pneumatic circuits to be constructed with the TP 101 and individual components to be replaced by defective ones. Using our experience in industrial environments, we were able to define typical error patterns for pneumatic systems and adapt them to the components contained in equipment set TP 101+.

Professional

Systematic troubleshooting and professional error elimination are an essential part of everyday operations in many jobs in the fields of mechanics, mechatronics, and electrical engineering. In order to acquire skills in this area via a structured, yet safe, procedure, it is important that systematic troubleshooting is both learned and practiced.

Keys to this are:

- Understanding circuits and discerning any non-conformities
- Delimiting/precluding fault areas
- Locating and rectifying faults

This procedure assumes specialist knowledge, such as modes of operation of individual components and their system limits.

Cylinder with worn piston seal

One example of a defective component is a double-acting cylinder with a worn piston seal. This defect may be due to damage to the piston rod or dirt entering the system. The defect leads to the cylinder leaking via the piston. Conspicuous symptoms result in compressed air losses and a lower cylinder force. Pressure sensors or force sensors may not switch, which can lead to interruptions in operation cycles or process safety being put at risk.

Clogged filters

Another example is a clogged filter in the on-off valve with pressure regulator (service unit). Filters are used to protect upstream components from contamination. If a large amount of contamination enters the system via the compressor's intake tract, these filters can become clogged. This applies in particular to micro filters. The defect results in increased flow resistance, and consequently, restricted flow, which in turn has a throttling effect. The inspection and replacement of such filters is a routine maintenance task in industry.

Complete equipment set TP 101+ in equipment tray **8060284**

The most important components at a glance :

1	1x Double-acting cylinder, defective	5042759
2	1x Pressure gauge, defective	4977328
3	1x Filter sleeves for on-off valve with filter regulator, clogged	8064260
4	1x 3/2-way valve with pushbutton actuator, normally closed, defective	4978036
5	1x 5/2-way bistable valve, defective	4977795
6	1x 5/3-way valve, mid-position pressurized	576305
7	1x Flow control valve	193972
8	1x Silencer M5, clogged	4977506

Accessories, also order:

Aluminum profile plate → Page 39

Compressor → Page 136

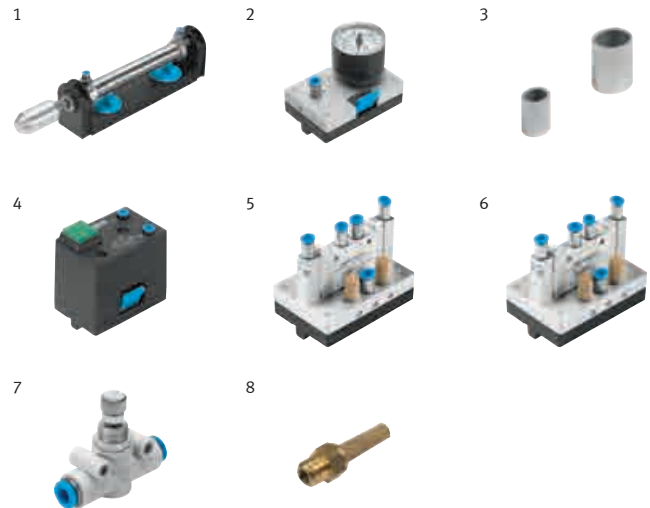

Requirements

Building on Basic Level Pneumatics, the Advanced Level contains eight components appropriate for equipment set TP 101. The possible troubleshooting tasks are aimed at all jobs involving maintenance and repair activities. Special measuring equipment is not required since all symptoms are observable. However, error patterns can also be quantified using measuring equipment such as a flowmeter.

Study materials

A description is included for each defective component describing both its function and the fault. A flow chart, which guides learners systematically from observation of the symptom to the repair task, is also included.

Supplementary media

- Design and simulation using FluidSIM®
- WBT: Pneumatics
- Textbook: Basic principles of pneumatics and electropneumatics
- Cutaway model case



From vocational education ...



... to industrial reality

Equipment set TP 102 – Advanced level

Advanced pneumatics training

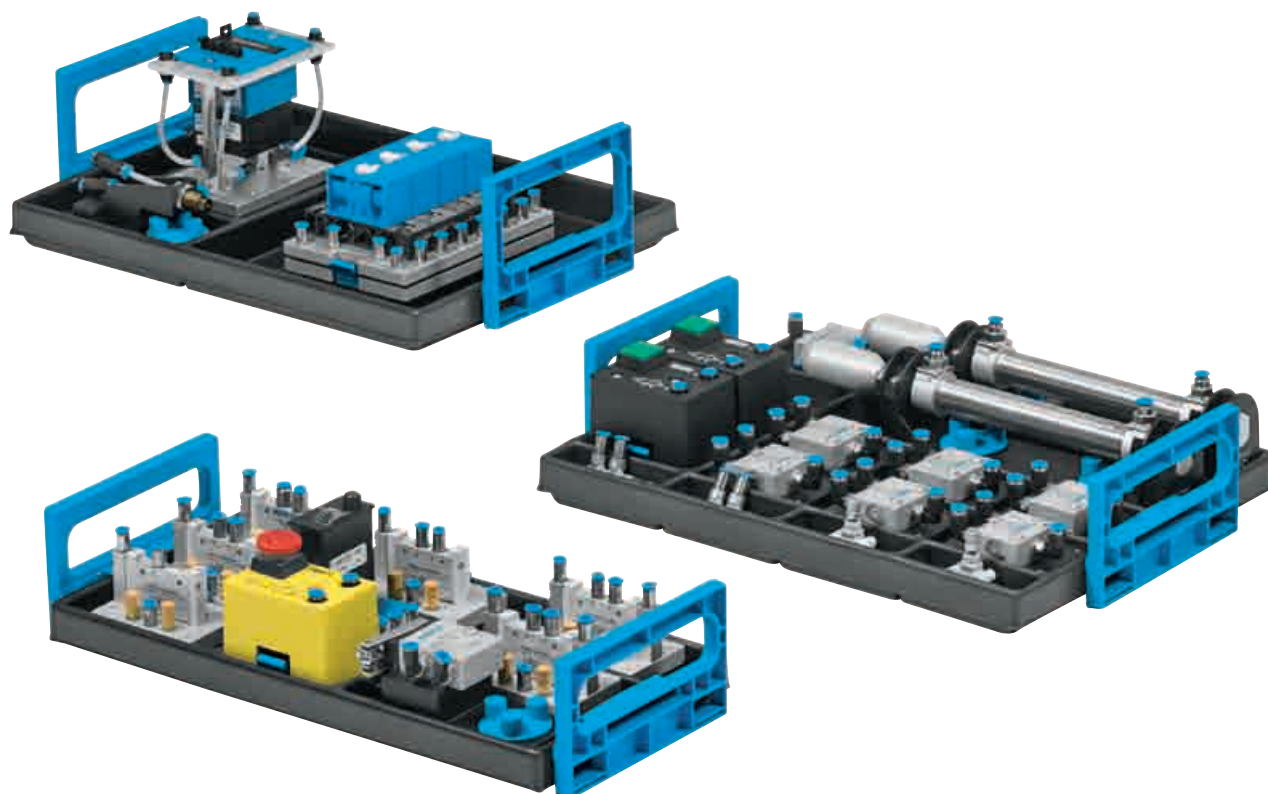

Develop the training aims from TP 101 and consolidate your knowledge.

Fully revised: The new workbook contains a series of progressively complex project exercises based on actual industrial applications and an enhanced section on fundamentals. It also includes a multimedia CD-ROM. The foundation for competent training. Place your order now!

The number of components and the design are specially tailored to the projects contained in the workbook so that the main training aims can be achieved with little outlay. Delivered in practical, Systainer-compatible equipment trays.

Components from the equipment set TP 101 are required to carry out the projects.

Training aims

- Binary reducing stages
- End positions without limit switches
- Latching circuits
- Converting 5/2-way valves
- Function of a back pressure end stop
- Basic stepper control (continuous cycle)
- Stepper control with operating modes or idle stop
- Setting and coordinating time delays
- Variable step repetition using a predetermining counter
- Input circuit with self-latching loop and auxiliary functions
- Evaluating and using sensors for material sensing
- Realizing stepper control with protected pilot air and auxiliary functions
- Proximity sensors in the end positions and in the partial stroke range
- Combined use of quick exhaust valves and pressure regulators
- Inversion of a timer signal
- Varying end-position cushioning
- Using and adjusting different sensor types

Performance through close proximity

For optimum performance, switches and valves should be mounted as close to the actuator as possible. With new components that can be plugged in directly, you can now apply the same principle when designing your circuits. This approach also provides you with an easy way of demonstrating the features of a one-way flow control valve. You can even record the measured values and analyze the results, for example, using the new TP 210!

Lever valves

All of the lever valves contained in the training packages 101 and 102 are equipped with a pilot control, which means they require a low actuating force and deliver high reliability.

Complete equipment set TP 102 in equipment tray 540711

The most important components at a glance :

1	2x 3/2-way valve with pushbutton actuator, normally closed	152860
2	1x 3/2-way valve with mushroom-head emergency switch, normally open	152864
3	1x 3/2-way roller lever valve with idle return, normally closed	152867
4	1x Back pressure valve	152868
5	4x 3/2-way valve, pneumatically actuated at one end	576302
6	2x 5/2-way double pilot valve, pneumatically actuated at both ends	576303
7	2x Plastic tubing, 4 x 0.75 silver 10 m	151496
8	4x Shuttle valve (OR)	539771
9	3x Dual-pressure valve (AND)	539770
10	1x Pneumatic timer, normally open	539759
11	1x Pneumatic preset counter	152877
12	1x Stepper module	152886
13	2x One-way flow control valve	193967
14	2x Non-return valve, delockable	540715
15	2x Double-acting cylinder	152888

Accessories, also order:

Aluminum profile plate → Page 39

Compressor → Page 136

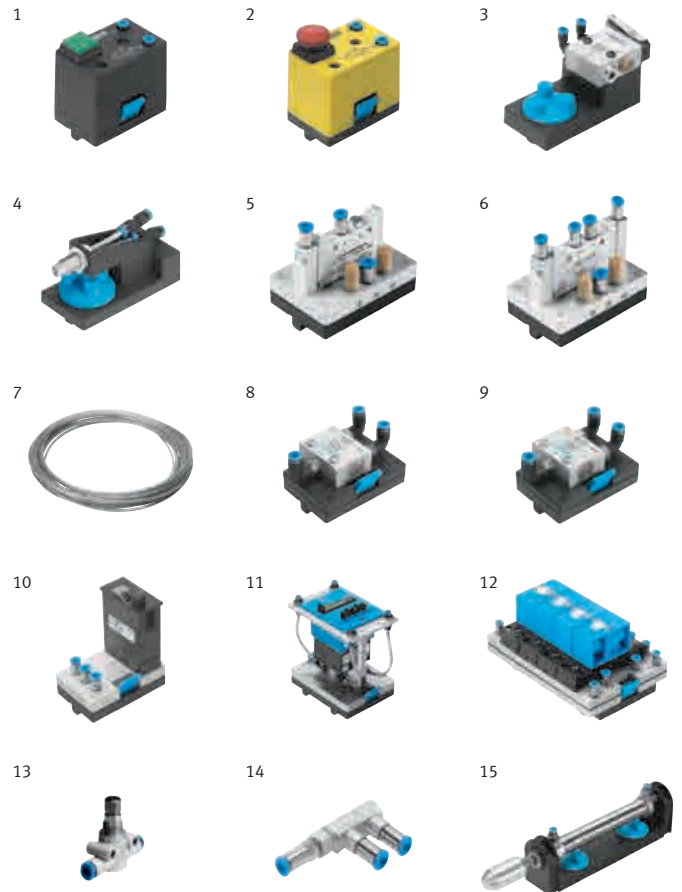

Also order:

Workbook

As a continuation of the basic level for pneumatics, the advanced level includes ten additional, challenging tasks which are suitable for the TP 102 equipment set. The documents are targeted at experienced pneumatics technicians. New features of this revised and updated edition include revised exercise sheets for practical use during instruction.

The workbook includes:

- Sample solutions
- Training notes
- Multimedia CD-ROM with graphics, photos of industrial applications, animations, and FluidSIM® circuit diagrams
- Exercise sheets for trainees

Campus license (→ Page 19):

de	540672
en	541089
es	542504
fr	542508

Supplementary media

- Design and simulation using FluidSIM®
- WBT Pneumatics
- Textbook: Basic principles of pneumatics and electropneumatics
- Cutaway model case

Equipment set TP 101 America – Basic level

Basic pneumatics training

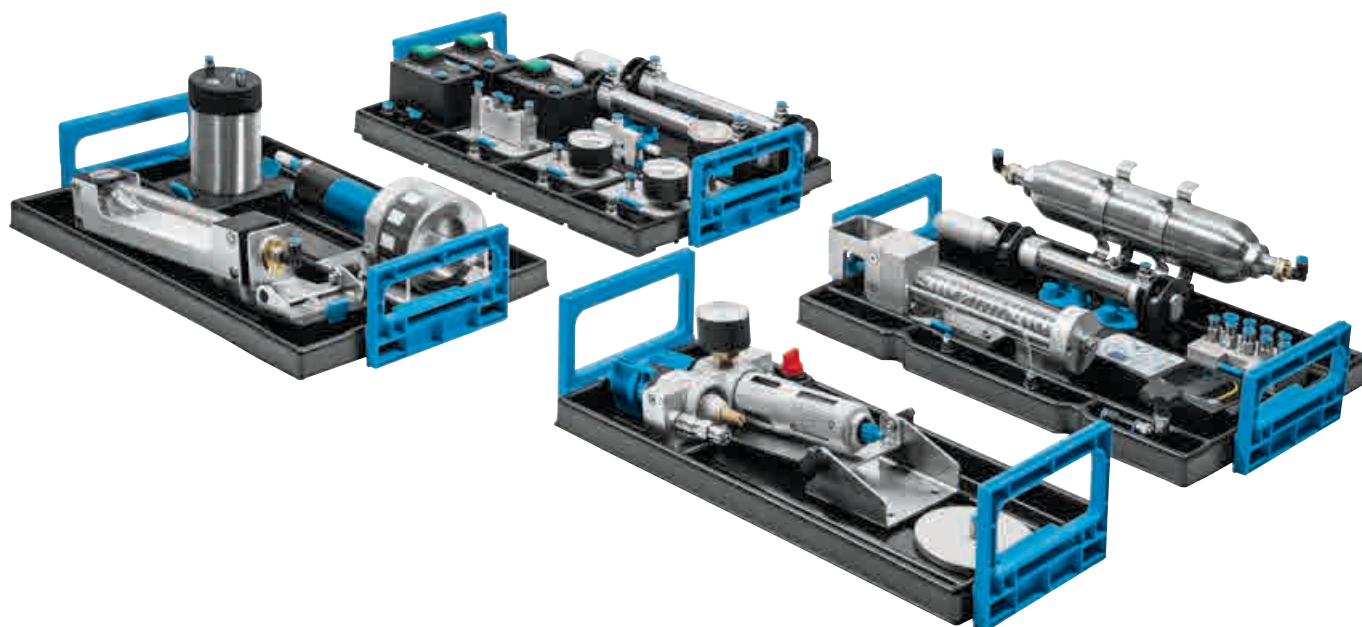

The Lab-Volt Pneumatics Fundamentals successor

The Lab-Volt Fluid Power System has been re-engineered and transferred to Festo Didactic's Training Packages series.

TP 101 America now combines the proven learning approach through object-oriented courseware from Lab-Volt with the project-orientation from Festo Didactic.

TP 101 America is the basic level for education in pneumatics and a prerequisite for TP 201 America, Electropneumatics Basic Level.

TP 101 and TP 201 America support vocational training institutes in their mission to educate skilled, resourceful technicians and engineers, as required by the local industry.

Education concept for future professionals

The course curriculum accompanying the learning system is designed to follow industry standards.

First, at the beginning of each exercise, meaningful objectives are clearly stated. Then, the theory to attain these objectives is laid out extensively, with an emphasis on component description. Next comes the laboratory procedure itself. In this section, students follow precise and safe working instructions designed to teach them the practical principles related to the stated objectives.

Throughout the laboratory procedure, questions and remarks ensure that students analyze and comprehend the results they obtain. Finally, review questions ascertain the degree of comprehension of students relative to the topics discussed in the exercise.

Safe and sound system

The design of the system components ensures a high level of inherent safety.

The On-Off Valve with Filter Regulator can be locked with a padlock to avoid unauthorized access to the compressed air supply.

The Spring Load for Cylinders comes with a safety cover to prevent potential hazards when high forces are involved.

The Air Motor is protected by a safety cover that does not compromise speed measurement capabilities. Work instructions and safety precautions are provided to students as required when working with pneumatic, electrical, and mechanical setups.

Training aims – TP 101 America

Introduction to Pneumatics
 – Familiarization with the Training System
 – Introduction to Pneumatics
 – Air Conditioning and Distributing Equipment

Basic Physical Concepts
 – Pressure vs. Force Relationship
 – Pressure vs. Volume Relationship
 – Pressure Drop vs. Flow Relationship
 – Vacuum Generation

Basic Controls of Cylinders
 – Directional Control Valves
 – Direction and Speed Control of Cylinders
 – Indirect Control Using Pilot-Operated Valves

Basic Controls of Pneumatic Motor
 – Pneumatic Motor Circuits
 – Pneumatic Motor Performance

Complete equipment set TP 101 America in equipment tray 8060282

The most important components at a glance :

1	1x Lockable on-off valve with filter regulator	4795290
2	2x Pressure gauge	152865
3	3x One-way flow control valve	193967
4	2x 3/2-Way-Panel mounted with pushbutton actuator, normally closed	152860
5	1x 3/2-Way- Panel mounted Valve with pushbutton actuator, normally open	152861
6	1x 5/2-way double pilot valve, pneumatically actuated at both ends	576303
7	1x Single-acting cylinder	152887
8	1x Double-acting cylinder, smooth running	4809915
9	1x Double-acting cylinder	152888
10	1x Air pressure reservoir, 0.4 l	152912
11	1x Vacuum generator, type H	573258
12	1x Vacuum gauge	573042
13	1x Suction gripper 20 SN	573043
14	2x Plastic tubing, 4 x 0.75 silver 10 m	151496
15	1x Manifold	152896
16	1x Contact tachometer	8062148
17	1x Spring load for cylinders, pneumatic	4646789
18	1x Compressed air motor	4645172
19	1x Air Bearing	4809899
20	1x Flow indicator with float, pneumatic	4741762
21	1x Pneumatic resistance, long	4646991
22	1x Pneumatic resistance, short	4809992
23	1x Plastic tubing, 6 x 1 silver 5 m	152963

Accessories, also order:

Workstations → Page 39

Compressor and accessories → Page 136

Also order:

Courseware TP 101 America



Detailed procedure descriptions with pneumatic diagrams, thorough analysis, troubleshooting exercises, and comprehensive theory coverage provide the ideal preparation for the real-life industrial environment.

Campus license (→ Page 19):

en **792258**

The Campus License consists of an Instructor Guide and a Student Manual.

In the courseware, exercises progressively increase in complexity, providing an ideal introduction to pneumatics.

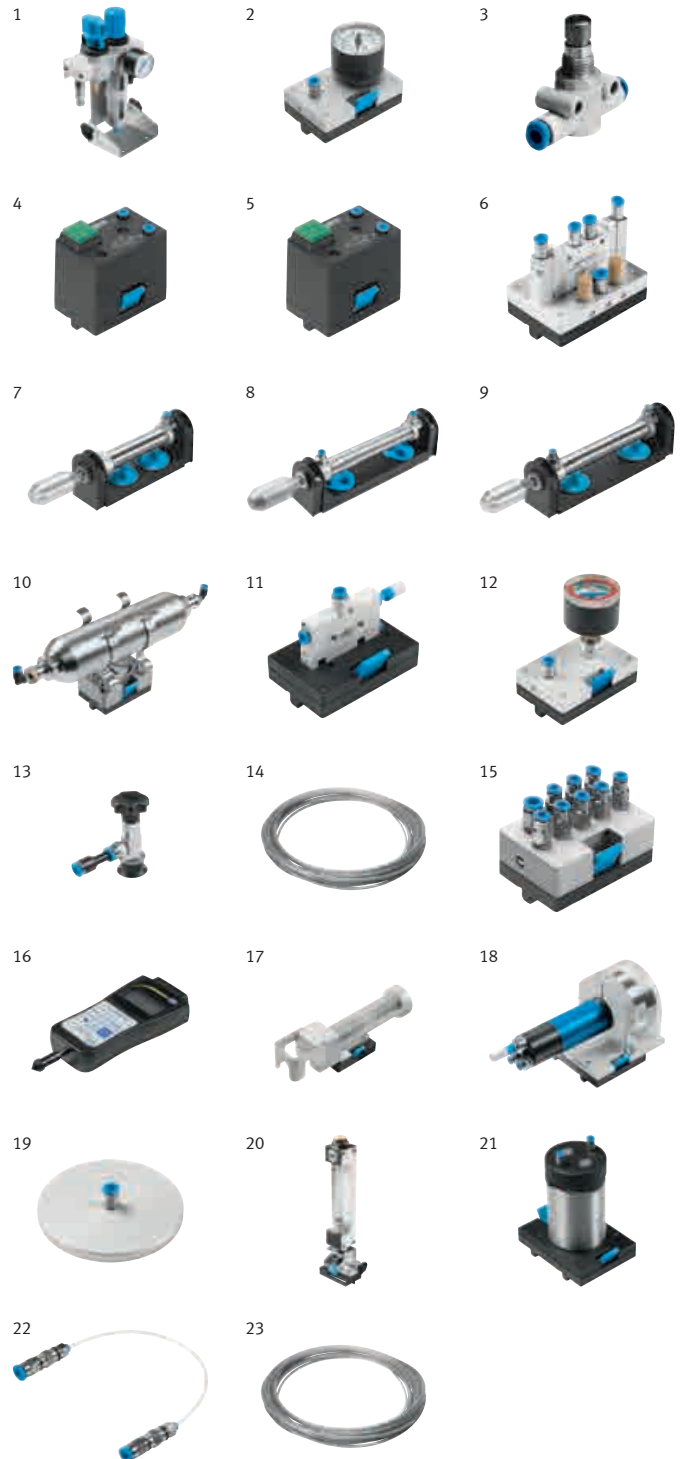

Equipment set TP 201 – Basic level

Basic electropneumatics training

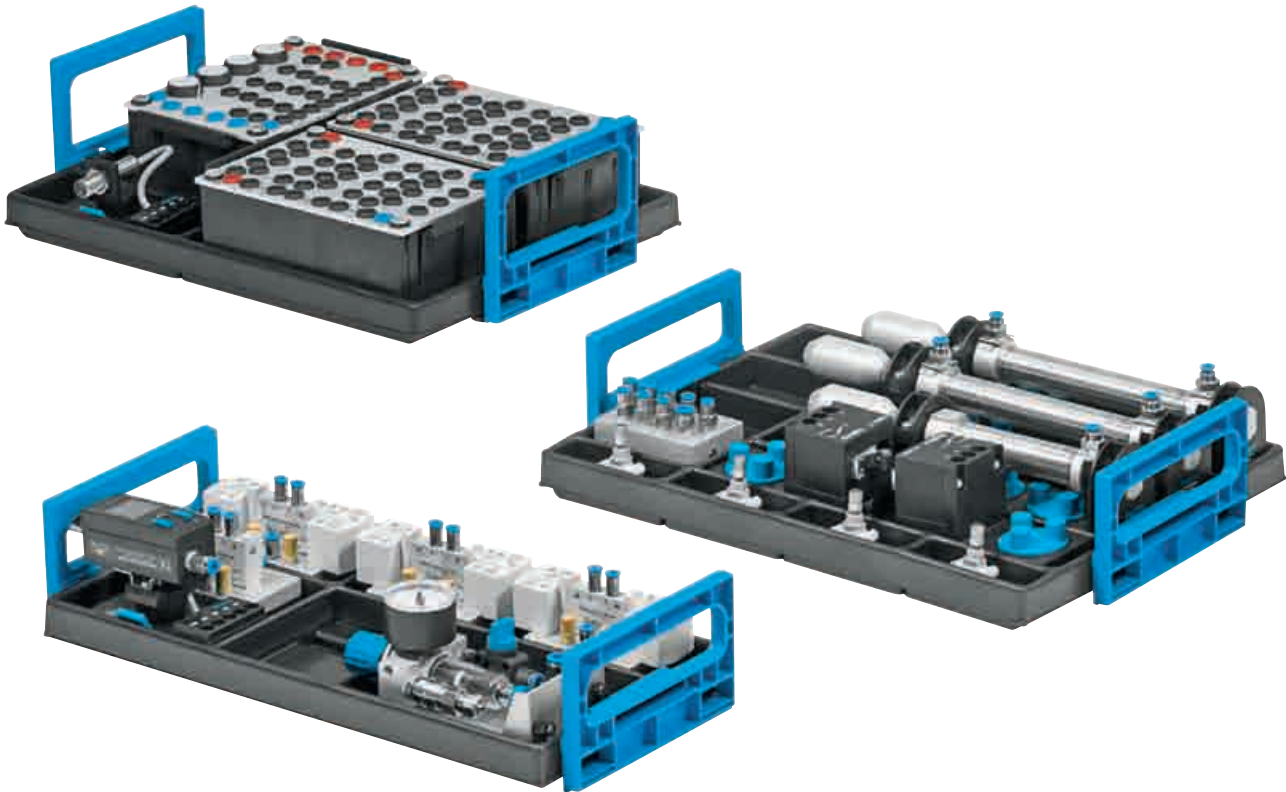

Electropneumatics, Basic level.
The most important basic principles in one compact book.

Top solenoid valves for training

Easy connection of the solenoid coils via 4 mm safety sockets with LED indicator for actuation. The manual override latches and allows very easy error simulation. The port pattern is as per the current symbols to DIN ISO 1219. The newest valve technology is compact, sturdy, and inexpensive with the Didactic-Plus, and of course comes with the reliable Quick-Fix mounting system.

Electronic proximity sensors – compatible and reliable

These proximity sensors are based on the same slot mounting system as the pneumatic proximity sensors in TP 101. We opted for short circuit-proof, electronic proximity sensors due to their long service life in training applications.

Logic programming? That's logical.

The basic principles are established with relay control systems and the new supplementary equipment sets “Controllers for fluid engineering” are used according to individual requirements.

Training aims

- Structure, function, and application of single-acting and double-acting cylinders
- Calculating basic parameters
- Direct and indirect actuation
- Application and function of 3/2 and 5/2-way solenoid valves
- Analyzing circuits
- Options for pressure measurement
- Pressure-dependent control systems
- Latching circuits
- Logic operations: AND/OR/NOT
- Combining logic operations
- Function and application of limit switches
- Time-delay valves
- End-position monitoring using electronic proximity sensors
- Realizing oscillating movement

- Economic considerations of using pneumatic components
- Troubleshooting simple electro-pneumatic circuits

The **workbook** contains a series of progressively complex project exercises based on actual industrial applications, an enhanced section on fundamentals, and a multimedia CD-ROM. The foundation for competent training. Place your order now!

The number and the design of components are specially tailored to the projects contained in the workbook so that the main training aims can be achieved with little outlay. Delivered in practical, Systainer-compatible equipment trays.

Also order:

Workbook



Campus license (→ Page 19):

de	540673
en	541090
es	542505
fr	542509

Supplementary media

- FluidSIM® Pneumatics
- WBT Electropneumatics
- Textbook: Basic principles of pneumatics and electropneumatics
- Transparency set, Electropneumatics

Complete equipment set TP 201 in equipment tray 540712

The most important components at a glance:

1	1x Signal input, electrical	162242
2	2x Relay, three-fold	162241
3	1x Limit switch, electrical, left-actuated	183322
4	1x Limit switch, electrical, right-actuated	183345
5	1x Proximity sensor, optical, M12	572744
6	2x Proximity sensor, electronic, with cylinder mounting	2344752
7	1x 2 x 3/2-way solenoid valve with LED, normally closed	567198
8	1x 5/2-way solenoid valve with LED	567199
9	2x 5/2-way double solenoid valve with LED	567200
10	1x Pressure sensor with display	572745
11	4x One-way flow control valve	193967
12	1x Single-acting cylinder	152887
13	2x Double-acting cylinder	152888
14	1x Start-up valve with filter control valve	540691
15	1x Manifold	152896
16	1x Plastic tubing, 4 x 0.75 silver 10 m	151496

Accessories, also order:

Aluminum profile plate → Page 39
Compressor → Page 136
Tabletop power supply unit → www.festo-didactic.com
Power supply unit for mounting frame → Page 159
4 mm Safety laboratory cables → Page 159

Supplementary equipment set to upgrade from Pneumatics, Basic level TP 101 to Electropneumatics, Basic level TP 201

Supplements the Pneumatics, Basic level TP 101 equipment set to form a complete Electropneumatics, Basic level TP 201 equipment set.

Recommended training media and accessories: See TP 201

Complete supplementary equipment set TP 101 – TP 201 in equipment tray 540717

The most important components at a glance:

1	1x Signal input, electrical	162242
2	2x Relay, three-fold	162241
3	1x Limit switch, electrical, left-actuated	183322
4	1x Limit switch, electrical, right-actuated	183345
5	1x Proximity sensor, optical, M12	572744
6	2x Proximity sensor, electronic, with cylinder mounting	2344752
7	1x 2 x 3/2-way solenoid valve with LED, normally closed	567198
8	1x 5/2-way solenoid valve with LED	567199
9	2x 5/2-way double solenoid valve with LED	567200
10	1x Pressure sensor with display	572745
11	2x One-way flow control valve	193967
13	1x Double-acting cylinder	152888

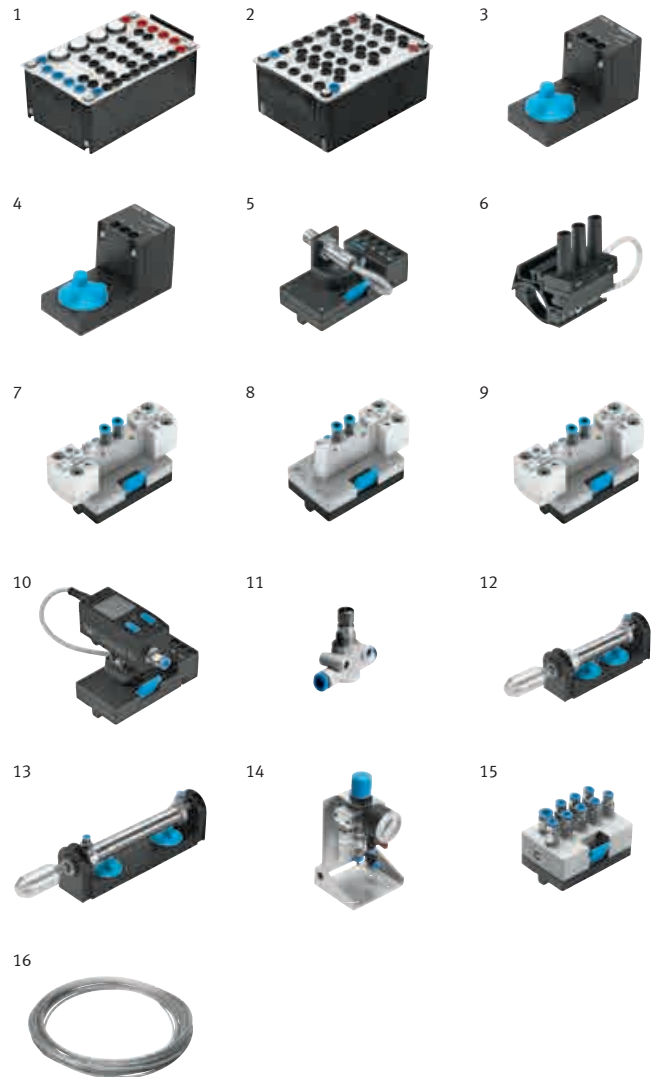

Equipment set TP 301

Programmable logic controllers

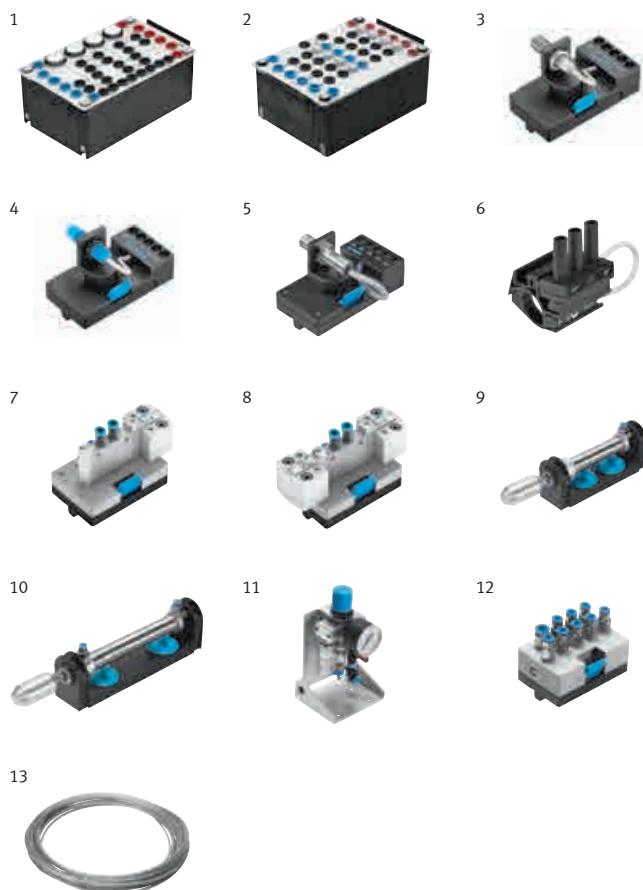

Complete equipment set TP 301 **167101**

The most important components at a glance:

1	1x Signal input, electrical	162242
2	1x Indicator unit and distributor, electrical	162244
3	1x Proximity sensor, inductive, M12	548643
4	1x Proximity sensor, capacitive, M12	548651
5	1x Proximity sensor, optical, M12	572744
6	4x Proximity sensor, electronic, with cylinder mounting	2344752
7	1x 5/2-way solenoid valve with LED	567199
8	1x 5/2-way double solenoid valve with LED	567200
9	1x Single-acting cylinder	152887
10	2x Double-acting cylinder	152888
11	1x Start-up valve with filter control valve	540691
12	1x Manifold	152896
13	2x Plastic tubing, 4 x 0.75 silver 10 m	151496

Recommended accessories:

Aluminum profile plate → Page 39	
Universal connection unit, digital (SysLink)	162231
Tabletop power supply unit → www.festo-didactic.com	
Power supply unit for mounting frame → Page 159	
4 mm Safety laboratory cables → Page 159	
EduTrainer → www.festo-didactic.com	

Supplementary equipment set from TP 201 to TP 301

Supplements the Electropneumatics basic level equipment set, TP 201, to form a complete Programmable Logic Controllers equipment set, TP 301.

Complete supplementary equipment set TP 201 – TP 301 **167102**

The most important components at a glance:

3	1x Proximity sensor, inductive, M12	548643
4	1x Proximity sensor, capacitive, M12	548651
6	2x Proximity sensor, electronic, with cylinder mounting	2344752

Training aims

- Benefits of the PLC compared to conventional solutions such as electrical, electropneumatic, or electrohydraulic solutions
- Functions of system components of a PLC
- Commissioning a PLC
- Application criteria for mechanical, optical, capacitive, and inductive proximity sensors
- Sequence control and parallel logic
- Systematic programming of a PLC in accordance with international standard IEC 1131-3
- IEC 1131-3 programming languages: Function Block Diagram, Ladder Diagram, Statement List, Structured Text, and Sequence Language

A PLC (Festo FC34, SIMATIC S7-300 or Allen Bradley) is required to carry out the tasks. Connection with universal connection unit and I/O data cable (SysLink) or with 4 mm safety connectors. I/O modules can be connected via 4 mm safety connectors.

Also order:

Workbook Programmable Logic Controllers, Basic level

Campus license (→ Page 19):

de	93313
en	93314
es	94427

Recommended training media

Textbook: Programmable Logic Controllers, Basic level

For additional controllers suitable for your requirements see:
 → www.festo-didactic.com
 Keyword "EduTrainer Compact"

Supplementary equipment sets

Controllers for electropneumatics

Supplementary equipment set Controlling using FluidSIM®/ EasyPort USB

With this package, the FluidSIM® software can be used to control training packages. FluidSIM® controls via EasyPort USB and processes the inputs and outputs connected to the universal connection unit according to their programming, e.g., using the digital module contained in FluidSIM®.

The Controlling using FluidSIM® package contains everything you need to control training packages TP 201 and TP 601. FluidSIM® Pneumatics is required for TP 201 and FluidSIM® Hydraulics for TP 601. A set of brief instructions provides information on the individual steps.

The sample solutions are included on a data storage medium as FluidSIM® CT programs.



Prerequisite:

Equipment set TP 201 – Basic level → Pages 56 – 57
FluidSIM Pneumatics → Pages 12 – 13

Necessary accessories, also order:

Aluminum profile plate → Page 39
Compressor → Page 136
Tabletop power supply unit → www.festo-didactic.com
Power supply unit for mounting frame → Page 159
4 mm Safety laboratory cables → Page 159

Complete supplementary equipment set Controlling using FluidSIM/EasyPort USB in equipment tray		556270
--	--	---------------

The most important components at a glance:

1	1x Brief instructions FluidSIM de/en/es/fr	556267
2	1x EasyPort USB	548687
3	1x Quick-Fix screw adapter	549806
4	1x Universal connection unit, digital (SysLink)	162231
5	1x I/O data cable with SysLink connectors (IEEE 488), 2.5 m	34031

Supplementary equipment set Controlling using LOGO! 8 TP EduTrainer® Compact TP/LOGO! Soft Comfort

A quick, straightforward, and inexpensive introduction to logical signal processing.

With its extensive basic and special control technology functions, LOGO! replaces a variety of conventional switchgears and control devices.

The LOGO! 8 TP EduTrainer® Compact training package contains everything you need to control training packages TP 201 and TP 601. A set of brief instructions provides information on the individual steps. Programming is carried out using the LOGO! programming software, Soft Comfort.

The sample solutions are included on a data storage medium as LOGO! Soft Comfort programs.



Prerequisite:

Equipment set TP 201 – Basic level → Pages 56 – 57

Necessary accessories, also order:

Aluminum profile plate → Page 39
Compressor → Page 136
Tabletop power supply unit → www.festo-didactic.com
Power supply unit for mounting frame → Page 159
4 mm Safety laboratory cables → Page 159

Complete supplementary equipment set with LOGO! 8 TP EduTrainer Compact TP/LOGO! Soft Comfort included in order		8049517
---	--	----------------

The most important components at a glance :

6	1x Brief instructions for LOGO!, de/en/es/fr	8049519
7	1x LOGO! 8 TP EduTrainer Compact TP	8040886
8	1x LOGO! Soft Comfort, de/en/es/fr	8040050
9	1x Ethernet cable	567280

For additional controllers suitable for your requirements see:
→ www.festo-didactic.com
Keyword “EduTrainer Compact”

Equipment set TP 202 – Advanced level

Advanced electropneumatics training

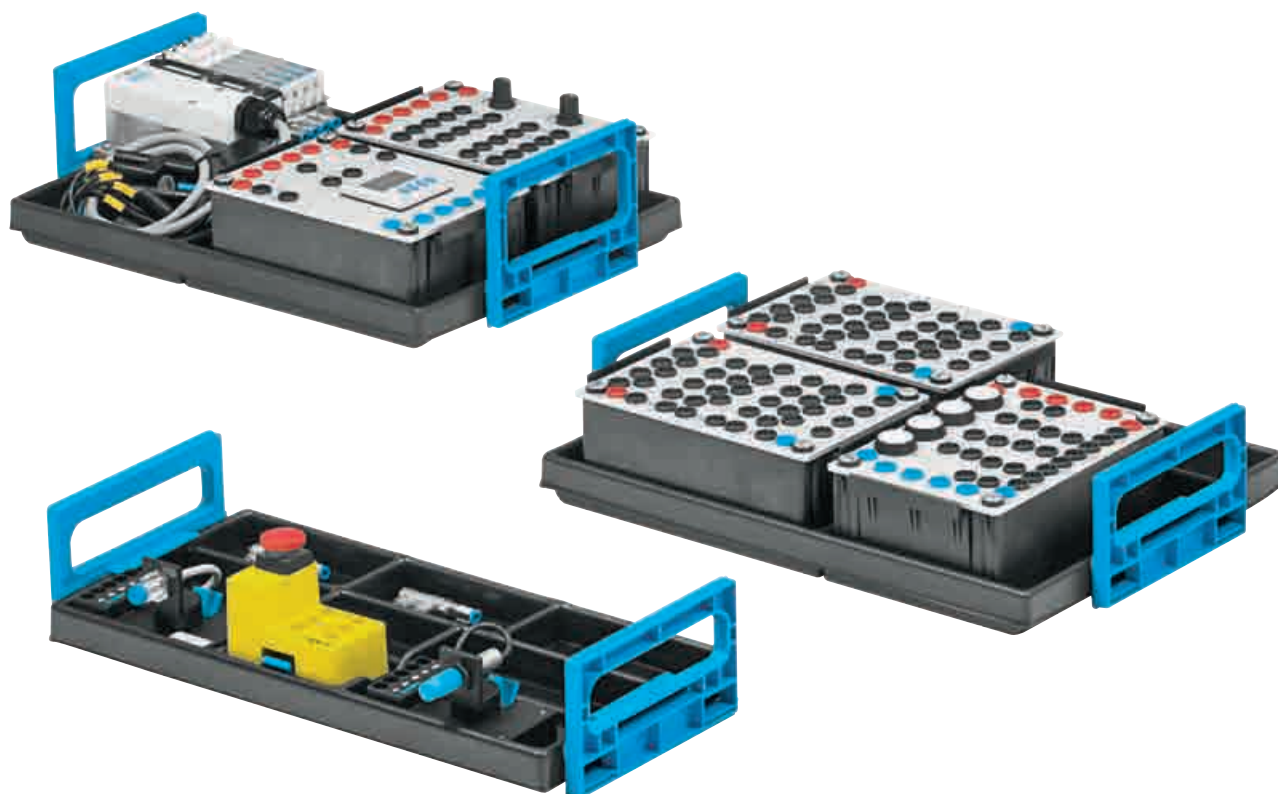

Electropneumatics, Advanced level. The next step!

This training package supplements the training aims of TP 201.

The new workbook contains a series of progressively complex project exercises based on actual industrial applications, an enhanced section on fundamentals, and a multimedia CD-ROM. The foundation for competent training. Place your order now!

The number and the design of components are specially tailored to the projects contained in the workbook so that the main training aims can be achieved with little outlay. Delivered in practical, Systainer-compatible equipment trays.

Components from the equipment set TP 201 are required to carry out the projects.

Training aims

- Describing the structure and application of valve terminals
- Realizing sequence controls with signal overlap – solution according to the group method, sequence chain with spring-return valves, and sequence chain with bistable valves
- Describing and setting operating modes
- Describing the function and application of a predetermining counter
- Explaining and realizing an emergency stop function using spring-return valves
- Emergency stop conditions
- Explaining the function and application of a 5/3-way solenoid valve
- Describing and setting the operating mode 'Set'
- Troubleshooting in complex electropneumatic circuits

Fundamentals of modern pneumatics – valve terminals

This training course helps you to lay the foundation for using valve terminals. Designed for a wide range of industries, requirements and applications, valve terminals are sturdy and durable – an investment in the future. The MPA valve terminal used consists of 2x 5/2-way solenoid valves and 2x 5/2-way double solenoid valves.

Electrical emergency stop pushbutton

Safety engineering is an important topic, but one that is often neglected in training. The new TP 202 takes an in-depth look at the emergency stop function and also describes the emergency stop function under special conditions. After all, you don't want to end up with a pressure-less and voltage-less system after pressing the emergency stop button!

Complete equipment set TP 202 in equipment tray 540713

The most important components at a glance:

1	1x Signal input, electrical	162242
2	2x Relay, three-fold	162241
3	1x Time relay, two-fold	162243
4	1x Preset counter, electronic	1677856
5	1x Emergency stop pushbutton, electrical	183347
6	1x Proximity sensor, inductive, M12	548643
7	1x Proximity sensor, capacitive, M12	548651
8	1x Valve terminal with 4 valve slices (MMJ)	540696
9	2x Non-return valve, delockable	540715

Accessories, also order:

Aluminum profile plate → Page 39
Compressor → Page 136
Tabletop power supply unit → www.festo-didactic.com
Power supply unit for mounting frame → Page 159
4 mm Safety laboratory cables → Page 159

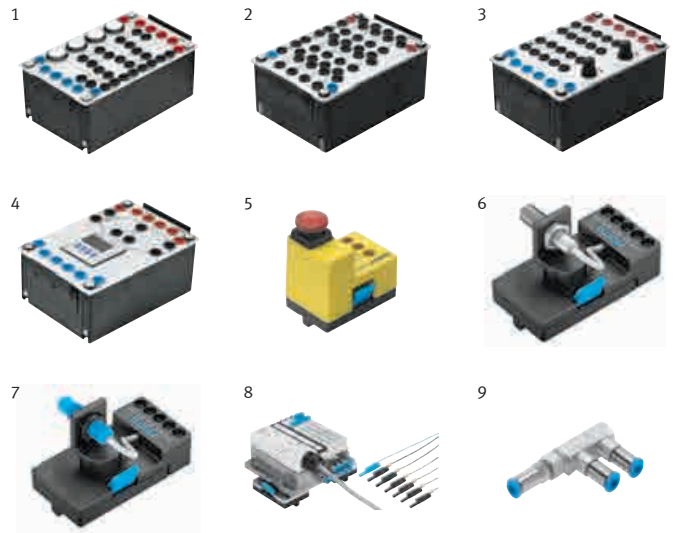

Also order:

Workbook



As a continuation of the basic level for electropneumatics, the advanced level includes twelve additional, challenging tasks which are suitable for the TP 202 equipment set. The documents are targeted at experienced pneumatics technicians. New features of this revised and updated edition include revised exercise sheets for practical use during instruction.

The workbook includes:

- Sample solutions
- Training notes
- Multimedia CD-ROM with graphics, photos of industrial applications, animations, and FluidSIM® circuit diagrams
- Exercise sheets for trainees

Campus license (→ Page 19):

de	540674
en	541091
es	542506
fr	542510

Supplementary media

- Design and simulation using FluidSIM®
- WBT Electropneumatics
- DVD Electropneumatics/ Electrohydraulics

Supplementary equipment set to upgrade from Pneumatics, TP 101 America to Electropneumatics, Basic level TP 201 America

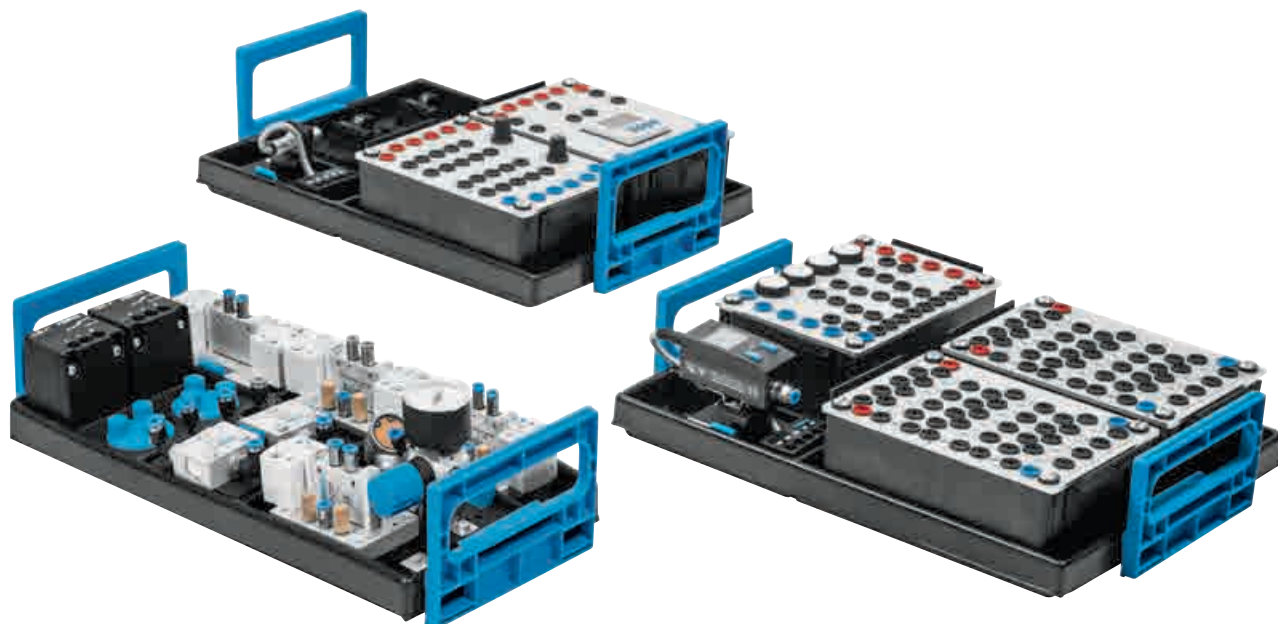

The LabVolt Pneumatics Electrical Control successor

The LabVolt Fluid Power System has been re-engineered and transferred to Festo Didactic's Training Packages series.

TP 201 America is an extension to TP 101 America and a comprehensive introduction to electropneumatics.

Equipment set TP 101 America is a prerequisite to use TP 201 America.

The electrical symbols in the courseware and on the modules are drawn according to NEMA standards. The design and simulation software FluidSIM provides all required NEMA symbols in easy-to-access component libraries. In addition, all circuits in the courseware procedures are available in FluidSIM for reference.

Training aims TP 201 America

Introduction to Electropneumatics
 – Familiarization with the Equipment
 – Electrical Concepts
 – Basic Electricity
 – Ladder Diagrams and Logic Operators
 – Basic Electropneumatic Circuits

Sequence Systems
 – Basic Memory and Priority
 – Multi-Pressure Systems
 – Sequencing Pneumatic Circuits
 – Time-Delay Electropneumatic Applications

Industrial Applications
 – Deceleration of Actuators
 – Counting of Actuator Cycles
 – Industrial Drilling System and Safety Circuits
 – Garbage Compactor Circuit

Troubleshooting
 – Troubleshooting Electrical Control Circuits
 – Troubleshooting Electropneumatic System

Workstation

As a prerequisite for the setup of any fluid power training system, a workstation is required. A wide range of workstations is available, from simple desktop arrangements to complete workplaces supporting customization possibilities.

Energy supply

A variety of compressors and DC power supplies are available.

Software for circuit design and simulation

Designing and planning can be pure fun with FluidSIM®.

Service and seminars

Our offering supports educational facilities to develop and speed up learning success.

Equipment set + Courseware = Training Package

The courseware exercises are tailor-made for the corresponding equipment set.

Next step:

our additions – your choice

A variety of possibilities can be added according to your educational needs.

Supplementary equipment sets:
 TP 210 – Measurement and control
 TP 220 – Different drive types in pneumatics
 TP 230 – Vacuum system technology
 TP 240 – Sensors in pneumatics
 TP 250 – Safety in pneumatic systems

Stand-alone basic level:

TP 111 – Basic closed-loop in pneumatics
 TP 1311 – Sensors for object detection

The electrical symbols in these supplements are drawn according to IEC standards. A NEMA/IEC conversion table is provided in the courseware of TP 201 America to support the implementation.

Complete supplementary equipment set TP 101 A – TP 201 A in equipment tray 8060283

The most important components at a glance:

1	2x Relay, three-fold	8062958
2	1x Signal input, electrical	8062950
3	1x Time relay, two-fold	8062960
4	1x Preset counter, electronic	8062962
5	1x Pressure sensor with display	8062966
6	1x Proximity sensor, optical, M12	8062967
7	2x Proximity sensor, electronic, with cylinder mounting	2344752
8	1x Limit switch, electrical, left-actuated	183322
9	1x Limit switch, electrical, right-actuated	183345
10	1x 2 x 3/2-way solenoid valve with LED, normally closed	567198
11	1x 5/2-way solenoid valve with LED	567199
12	1x 5/2-way double solenoid valve with LED	567200
13	1x 5/3-way solenoid valve, mid position closed	567201
14	1x Quick-exhaust valve	539772
15	1x Pressure regulator valve with pressure gauge	539756
16	1x Dual-pressure valve (AND)	539770
17	1x Shuttle valve (OR)	539771
18	1x Plastic tubing, 4 x 0.75 silver 10 m	151496

Accessories, also order:

Workstation → Page 39	
Compressor and compressor accessories → Page 136	
Tabletop power supply unit → www.festo-didactic.com	
Power supply unit for mounting frame (NEMA 5-15 plug)	162411
4 mm Safety laboratory cables, 106 pieces, red, blue, and black	8092668

Also order:

Courseware TP 201 America



Detailed procedure descriptions with pneumatic and electrical diagrams, thorough analysis, troubleshooting exercises, and comprehensive theory coverage provide the ideal preparation for the real-life industrial environment.

Campus license (→ Page 19):

en **595180**

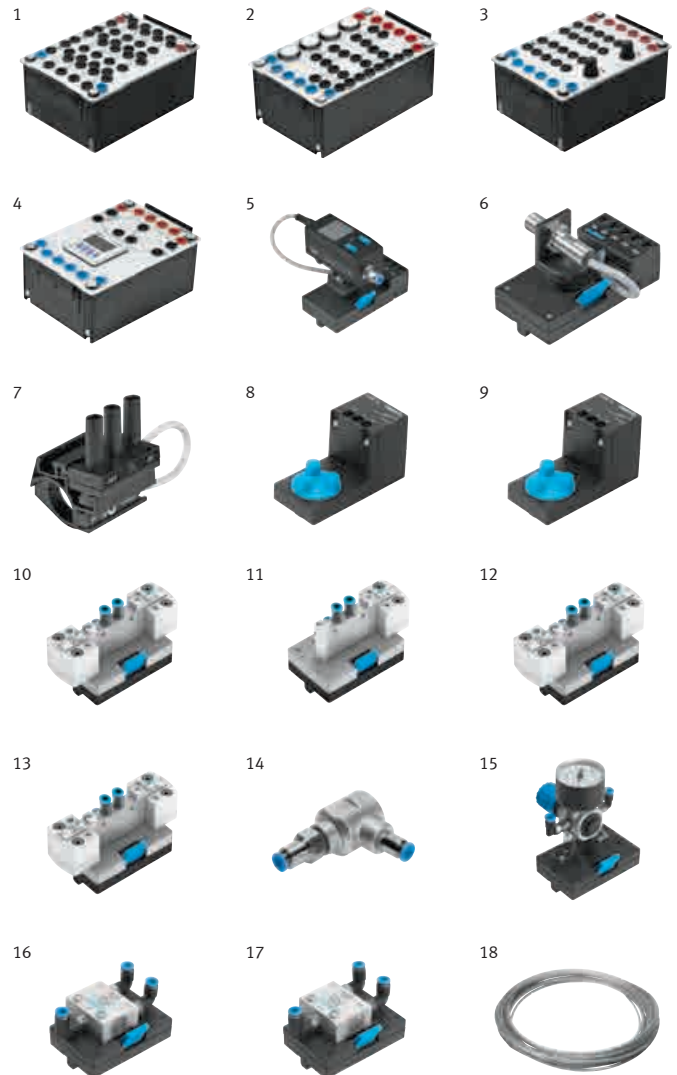

The Campus License consists of an Instructor Guide and a Student Manual.

In the courseware, exercises progressively increase in complexity, providing an ideal introduction to electro-pneumatics.

Equipment set TP 210 – Advanced level

Measurement and control in pneumatics with FluidLab®-P

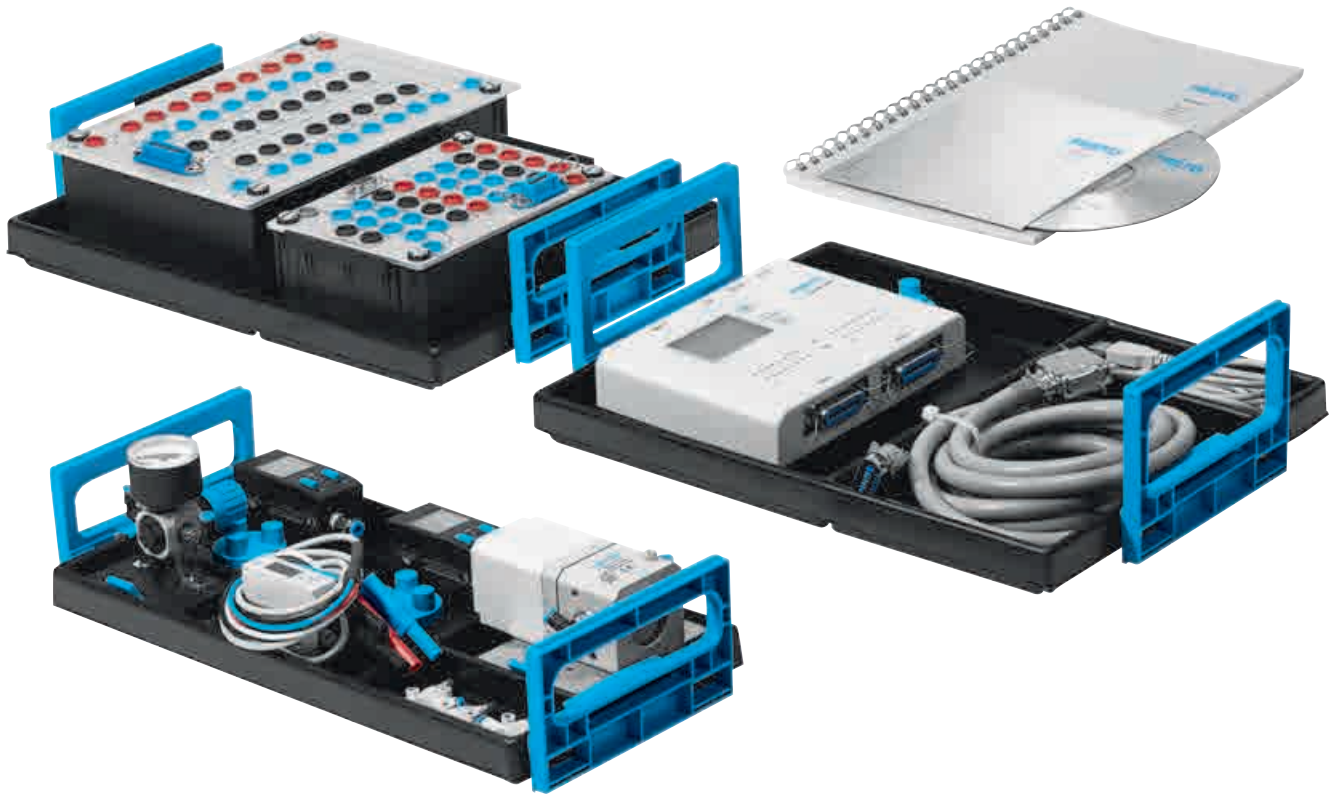

Fit for tomorrow?

The TP 210 equipment builds on the training content of the TP 101 and TP 201 equipment sets on the topic of pneumatic measurement and control. The training content ranges from the simple measurement of individual, pneumatic components, basic principles of status monitoring (condition monitoring) to (closed-loop) control technology with discontinuous (two-step action controller) and continuous controllers (PID controller).

In addition, great emphasis is placed on raising awareness of how to handle compressed air responsibly as a form of energy.

Exercises for measuring and analyzing system and control behavior help you to prepare for a future in which diagnostics, preventative maintenance, and saving energy are becoming increasingly important.

Something extra special

In order to complete the exercises, sensors (e.g., pressure, flow and proximity sensors) are connected to the inputs and control signals are guided to the EasyPort USB outputs. The signals are interpreted and visualized on computer by the FluidLab®-P software included in the scope of delivery. Analog values are displayed as measurement curves.

Instructions on how to complete the exercises, positional sketches, and block circuit diagrams are included with each exercise, so that students are guided step-by-step through each of the tests. Measured results are then interpreted and compared with sample solutions, and students will be asked to answer questions about comprehension.

Course topics

- Basic principles of analog data processing
- Application and adaptation of sensors
- Interpretation of measurement results
- Reading and understanding of technical data and measurement curves
- Fluid engineering components, their influence and function
- Demonstrating fluid engineering effects and special features
- Analytical fault finding
- Saving energy
- Evaluation of changes in status
- Proportional technology
- Control technology with continuous and discontinuous controllers

The benefits to you

- Fast, PC-supported recording of measured values
- Greater training success through measurement of components and interpretation of results
- Sensors that enable students “to look into” the circuit and components
- Suppositions regarding system behavior can be easily proven
- Learning the principles of measurement and analysis and applying them directly in other circuits
- Demonstrating and understanding the principles of fluid engineering faster
- System analysis via PC: state-of-the-art diagnostic method
- Better understanding of fluid engineering components and processes and thus higher quality of training

Complete equipment set TP 210 in equipment tray 556228

The most important components at a glance:

1	1x I/O data cable with SysLink connectors (IEEE 488) at both ends, 2.5 m	34031
2	1x Universal connection unit, digital (SysLink)	162231
3	1x Connection unit, analog	567232
4	1x Analog cable, parallel, 2 m	529141
5	1x EasyPort USB	548687
6	1x Quick-Fix screw adapter	549806
7	2x Pressure sensor with display	572745
8	1x Flow sensor, 0.5 – 50 l/min, analog	8036235
9	1x Proportional-pressure regulator	539779
10	1x Pressure regulator valve with gauge	539756
11	3x Flow control valve	193972
12	1x Plastic tubing, 4 x 0.75 silver 10 m	151496
	1x FluidLab-P Single license, de/en	556241
	2x Non-return valve, delockable	540715

Option: force measurement

For piston force measurement exercises, the force sensor (order no. 539780) not included in scope of delivery, is required.

Accessories, also order:

Aluminum profile plate → Page 39	
Compressor → Page 136	
Tabletop power supply unit → www.festo-didactic.com	
Power supply unit for mounting frame → Page 159	
4 mm Safety laboratory cables → Page 159	
Force sensor	539780

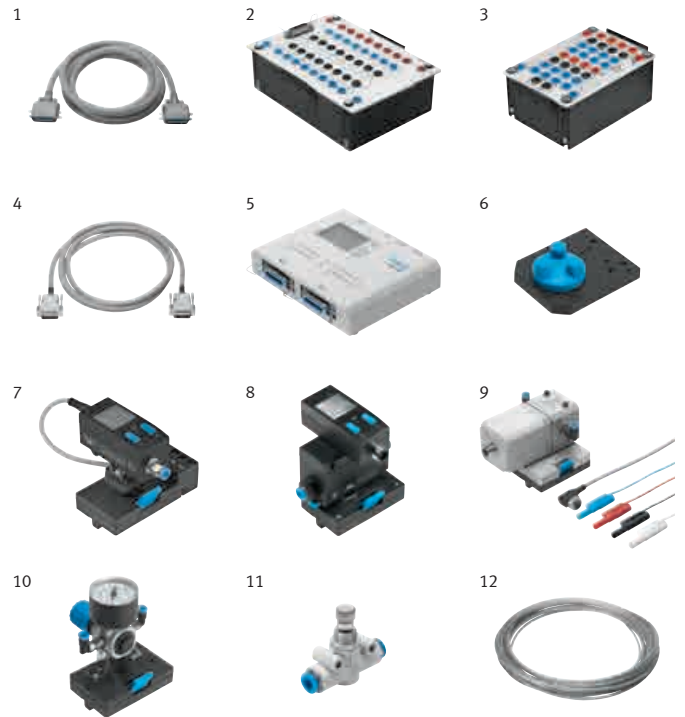

FluidLab®-P inclusive

The FluidLab®-P software for recording measured values is an important component of the training package TP 210. Just a few simple steps are needed to configure the interface, adapt the sensors, and select the language. Exercises can then be started, which are divided into the areas, basic tests, cylinder controls, proportional technology, and control technology. Exercises are supported by connection diagrams, descriptions, and sample solutions. The measurement process is also software-controlled. Results can be measured with measuring points, printed out, or exported to a spreadsheet program. The software also includes the complete book of exercises in PDF format.

System requirements

- PC with Windows 7/8/10
- Pentium® III or equivalently
- 2 GB RAM
- CD-ROM disk drive
- USB 2.0 or serial interface
- 1280 x 1024 pixels
- NI LabView 2012 Runtime (included in scope of delivery)

Components from the TP 101 and TP 201 equipment sets are required in order to complete the exercises.

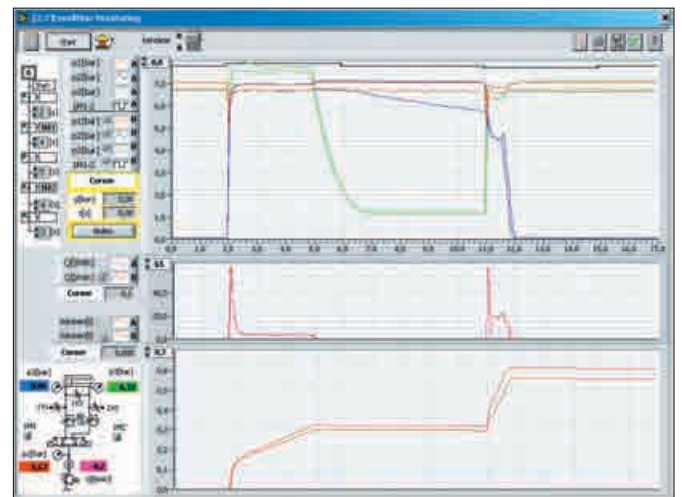

Equipment set TP 220 – Advanced level

Drives in pneumatics

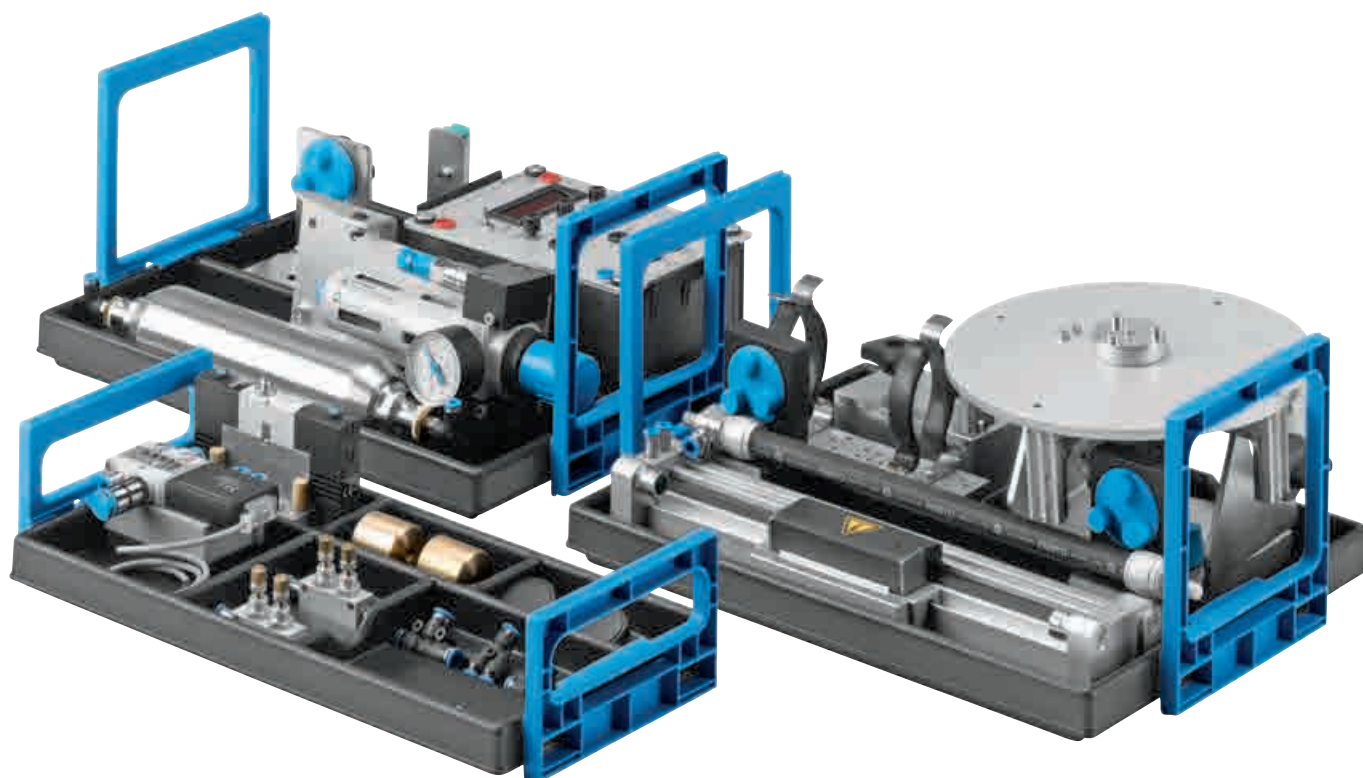

Optimum drive

The TP 220 supplements the TP 201 training package by teaching the basics of pneumatic drives. The training content features the selection and sizing of various state-of-the-art drive types, taking into account their individual properties, as well as commercial and safety considerations. Each drive unit remains clearly defined as an individual design, meeting the needs of the various entry levels. Use of industrial components throughout emphasizes the essential practicality and ensures rapid transfer of knowledge from training into practice.

We recommend connection to a compressed air system delivering approx. 100 l/min.

Training aims

- Designing a compressed air network
- Sizing the pneumatic power section
- Influence of tubes and fittings on speed
- Reducing cost by using different pressures for advance and return strokes
- Reducing cost by avoiding leakage
- Operating behavior of linear drives
- Calculation of mass moment of inertia
- Operating characteristics of rotary drives
- Function, control, and selection of the fluidic muscle
- Comparison between standard cylinders and the fluidic muscle
- Response of pneumatic controls to power failure

Also order:

Workbook



Describes in detail the issues and projects in 16 exercises closely linked to industrial practice, each comprising a problem description and work assignment. Worksheets support the students through the required stages of planning, execution, and monitoring.

The workbook includes:

- Sample solutions
- Training notes
- Multimedia CD-ROM with graphics, photos of industrial applications
- Exercise sheets for trainees

Campus license (→ Page 19):

de	549982
en	559880
es	559881
fr	559882

Complete equipment set TP 220 in equipment tray **541184**

The most important components at a glance:

1	1x Fluidic muscle, size 10	544311
2	1x Semi-rotary drive, size 16, 180°	544313
3	1x Linear drive, size 18, 170 mm stroke	548641
4	1x Function generator/counter/stopwatch	544315
5	1x 3/2-way fast-switching solenoid valve, normally closed	544312
6	1x 5/3-way solenoid valve, mid position closed	567201
7	2x One-way flow control valve	548634
8	1x Proximity sensor, electronic	2342009
9	1x Start-up valve with filter control valve	540691
10	2x Weight, 175 g	548581
11	1x Weight, 2 kg	548582
12	1x Air pressure reservoir, 0.4 l	152912

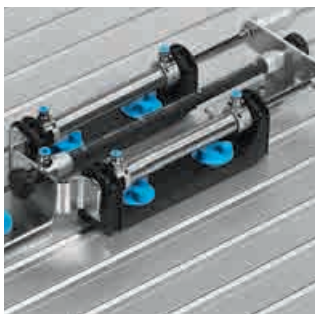
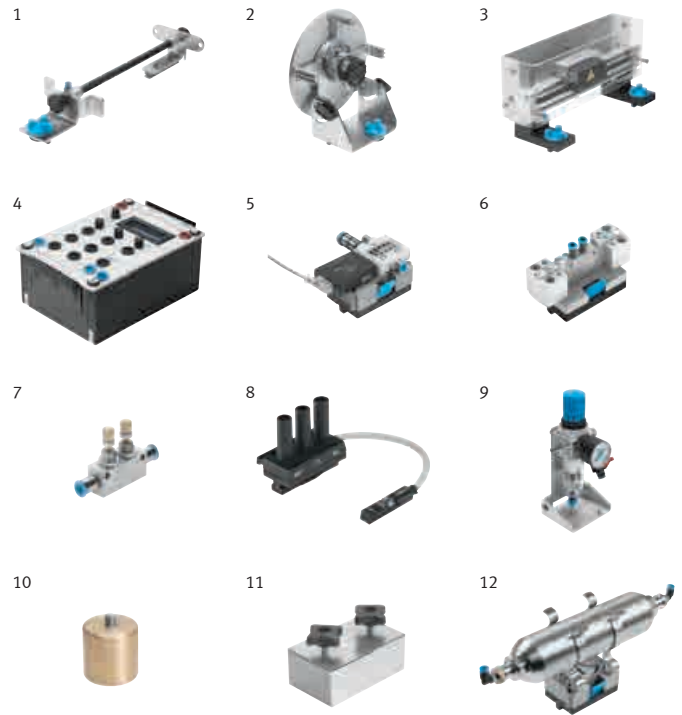

Fluidic muscle

The fluidic muscle is a pull actuator which imitates the action of a biological muscle. Shudder free, it offers up to 10 times the initial force of normal cylinders of the same diameter. You will learn how the muscle can be deployed as a single-acting actuator.

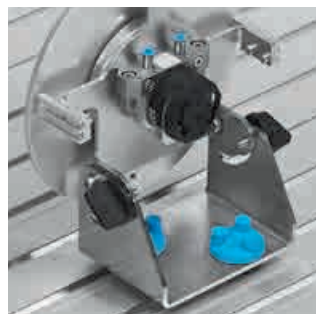

Semi-rotary drive

In a semi-rotary drive the force is transmitted directly to the drive shaft via a rotary vane. The swivel angle is freely adjustable from 0 to 180°. You will learn the significance of the mass moment of inertia to a semi-rotary drive, and how its operating behavior under load can be influenced in various mounting positions.



Linear drive

The rodless cylinder is mechanically coupled to the slide unit, which directly supports loads. You will learn the steps needed to attain optimum operating behavior, and which applications are most suited to the various options.

Equipment set TP 230 – Advanced level

Vacuum technology

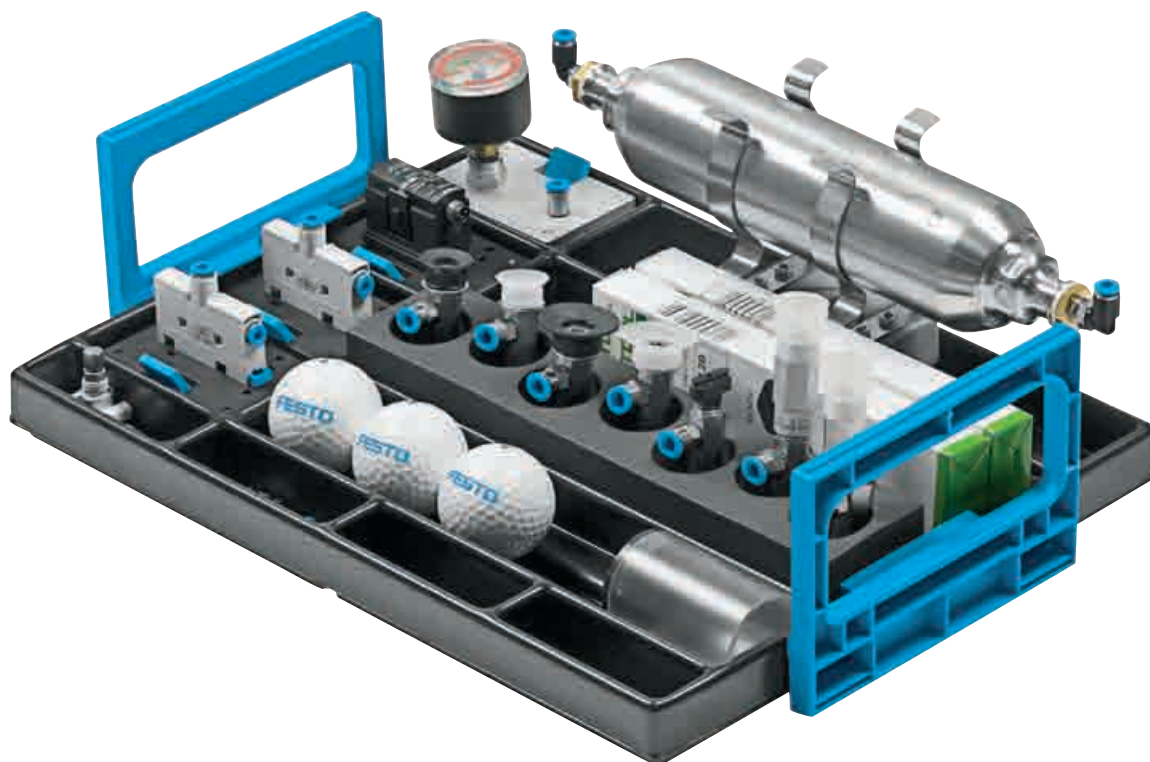

Vacuums in handling technology

Training package TP 230 continues the training content in TP 201, focusing on the topic of handling technology using a vacuum.

The use of suction grippers to handle workpieces has become an integral part of handling technology, as they offer advantages such as the ease of construction and the gentleness of the grippers. Suction grippers also enable rapid cycle times, and the investment required is comparatively low.

Training content

Low pressure generation and system design:

- Function and use of ejectors according the Venturi principle
- Effects of system pressure on the attainable low pressure and the evacuation time
- Sizing and setting up a vacuum system

Selecting suction grippers:

- Shape and materials
- The relevance of gripper types and workpiece shape
- How the holding force is affected by the workpiece surface and the diameter of the suction cup

Typical switching for a vacuum system:

- Using a vacuum security valve when some of the suction cups are not gripping
- Using a pressure switch to monitor the low pressure level
- Reducing the compressed air consumption in a vacuum system
- Controlled release and ejection of workpieces from the suction gripper

Components from the equipment set TP 201 are required to carry out the projects.

All the workpieces required to complete the tasks are included in the scope of delivery.

Complete equipment set TP 230 in equipment tray **573041**

The most important components at a glance:

1	1x Air pressure reservoir, 0.4 l	152912
2	1x Pressure switch, 0 – -1 bar	548624
3	1x Vacuum gauge	573042
4	1x Flow control valve	193972
5	1x Vacuum generator, type H	573258
6	1x Vacuum generator, type L	573259
7	1x Non-return valve	153462
8	1x Non-return valve, delockable	540715
9	1x Suction gripper 20 SN	573043
10	1x Suction gripper 30 SN	573044
11	1x Suction gripper 20 SS	573045
12	1x Suction gripper 30 SS	573046
13	2x Suction gripper 20 CS with vacuum security valve	573047
14	1x Suction gripper 4x20 ON	573257
Different materials and workpieces		

Necessary accessories, also order:

Aluminum profile plate → Page 39
Compressor → Page 136
Tabletop power supply unit → www.festo-didactic.com
Power supply unit for mounting frame → Page 159
4 mm Safety laboratory cables → Page 159

Also order:

Workbook



In addition to six comprehensive project tasks for step-by-step construction and testing of the vacuum system, the package also includes basic information on the following topics: **Introduction to vacuum technology** – basic concepts of vacuum technology, vacuum ranges, vacuum generation in handling technology, vacuum pumps, functional principle of displacement pumps, instructions on selecting pumps, ejectors, ejector units.

Vacuum elements in handling technology – valves for vacuums, measuring and storing a vacuum, suction grippers, vacuum generation.

The workbook contains:

- Sample solutions
- Training notes
- Multimedia CD ROM with graphics and photos of industrial applications
- Worksheets for students

Campus license (→ Page 19):

de	567257
en	567258
es	567260
fr	567259

Supplementary media

- Designing and simulating with FluidSIM®
- Measuring and controlling with FluidLab®
- WBT Pneumatics
- WBT Electropneumatics
- Textbook: Pneumatics/ electropneumatics
- Set of posters on pneumatics

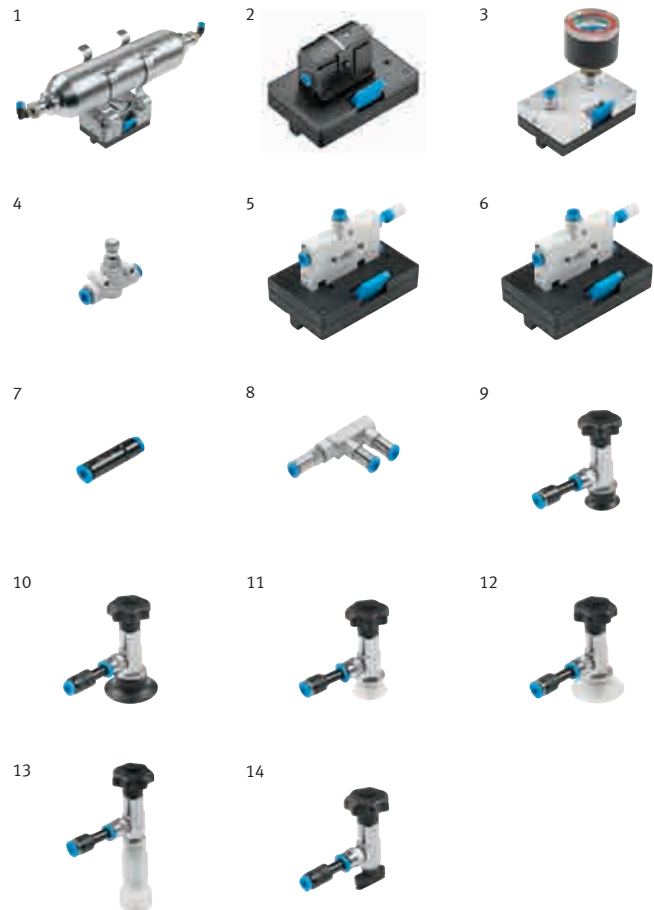

Equipment set TP 240 – Advanced level

Sensors in pneumatics

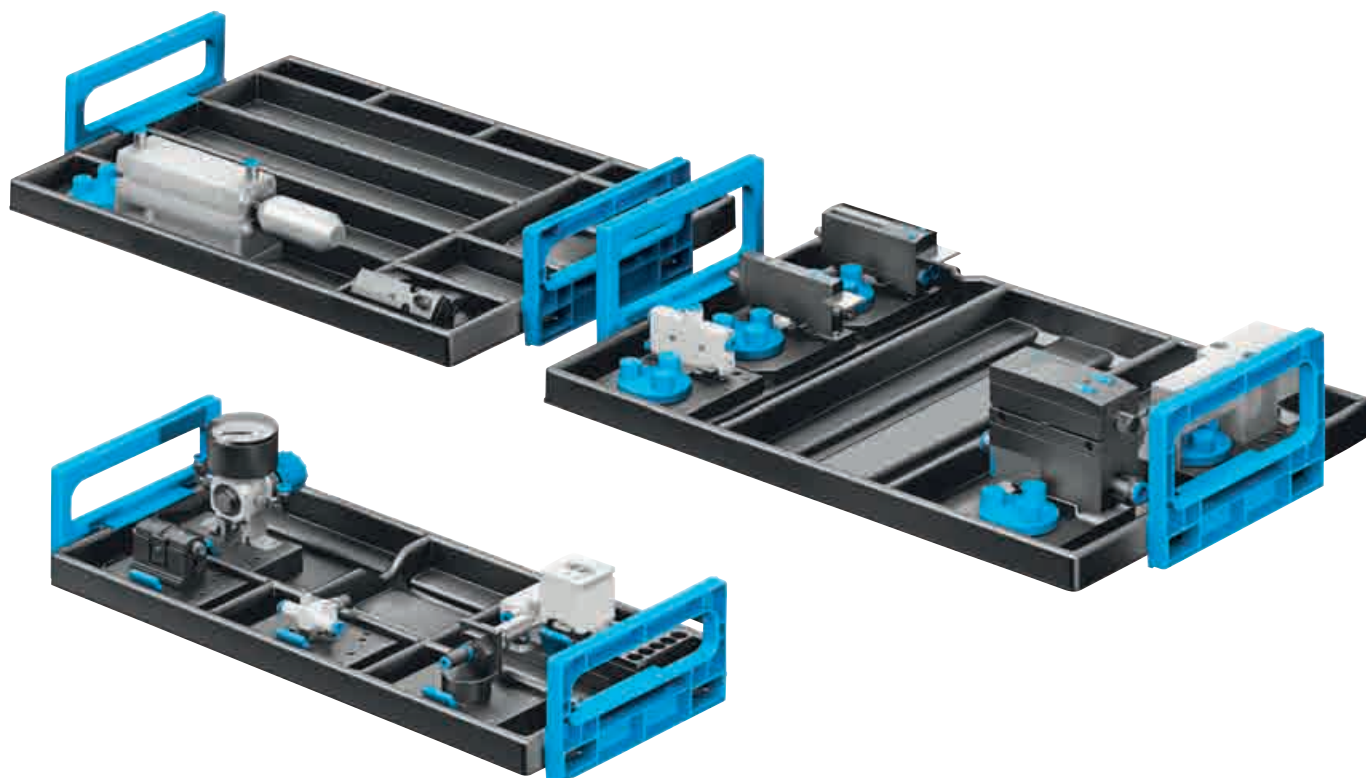

The purpose of a pneumatic control system

By using the TP 240 equipment set, you can expand the course topics of the TP 201 training package to include the topic of sensors in pneumatics.

With topics such as the application of pressure and flow rate sensors, the use of analog position transmitters including the integration of signal converters, and sensors for vacuum technology – the special requirements of sensors in pneumatic control-system environments are covered extensively.

Components from the TP 201 are required to carry out the projects.

The special feature

The new advanced level is all about the subject of sensors in pneumatic control systems.

Hands-on experience plays a decisive role in teaching the contents. Examples are used to demonstrate the general operational principles of different sensors. Special attention is paid to the selection of the right sensor, its connection, the correct setting, and functional checking.

With the TP 240 a basic knowledge of sensors in pneumatics can be thoroughly conveyed.

Course topics

- Basic principles of connection and circuit technology
- Basic principles of measured data acquisition and processing
- Configuration, function, and application options of the sensors used
- Selecting appropriate sensors by taking into account certain parameters
- Various methods of pressure and flow measurement
- Differences between absolute, relative, and differential pressure measurement
- Setting and checking sensors
- Using signal converters

Complete equipment set TP 240 in equipment tray **566908**

The most important components at a glance :

1	1x Position transmitter, 0 – 50 mm, analog	560124
2	1x Signal converter for position transmitter	548621
3	1x Electronic pressure sensor, 0 – 10 bar	548622
4	1x Flow sensor, 0.5 – 50 l/min, analog	8036235
5	1x Pressure switch, 0 – 1 bar	548624
6	1x Vacuum generator	548628
7	1x Suction gripper, 10 mm diameter	560158
8	1x One-way flow control valve	560159
9	1x Pressure regulator valve with gauge	539756
10	1x Stop, 35 mm adjustment path	548630
11	1x Double-acting profile cylinder	549832

Accessories, also order:

Aluminum profile plate → Page 39

Tabletop power supply unit → www.festo-didactic.com

Power supply unit for mounting frame → Page 159

4 mm Safety laboratory cables → Page 159

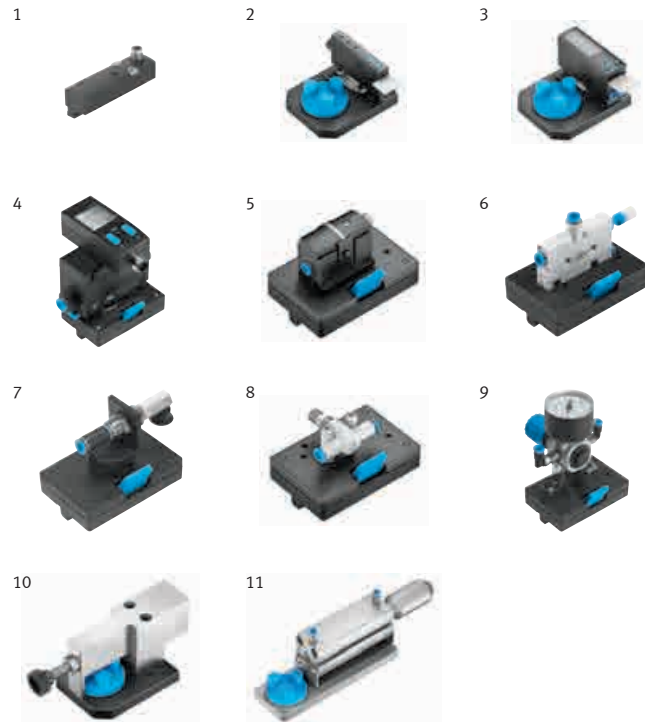

Also order:

Workbook



Ten projects based on industrial examples, suitable for equipment set TP 240, each including problem descriptions, parameters, and project tasks, deal in detail with the specific subject of sensors in pneumatic control-system environments. The topics of pressure sensors, flow sensors, analog position transmitters for pneumatic cylinders, signal converters, and sensors for vacuum technology are covered comprehensively.

The workbook includes:

- Sample solutions
- Training notes
- Multimedia CD-ROM with graphics, photos of industrial applications, animations
- Exercise sheets for trainees

Campus license (→ Page 19):

de	566909
en	566910
es	566912
fr	566913

Supplementary media

- WBT sensor technology 1
- Textbook: Proximity switches
- Design and simulation using FluidSIM®
- Measurement and control using FluidLab®
- Set of posters on pneumatics

Equipment set TP 250 – Advanced level

Safety in pneumatic systems

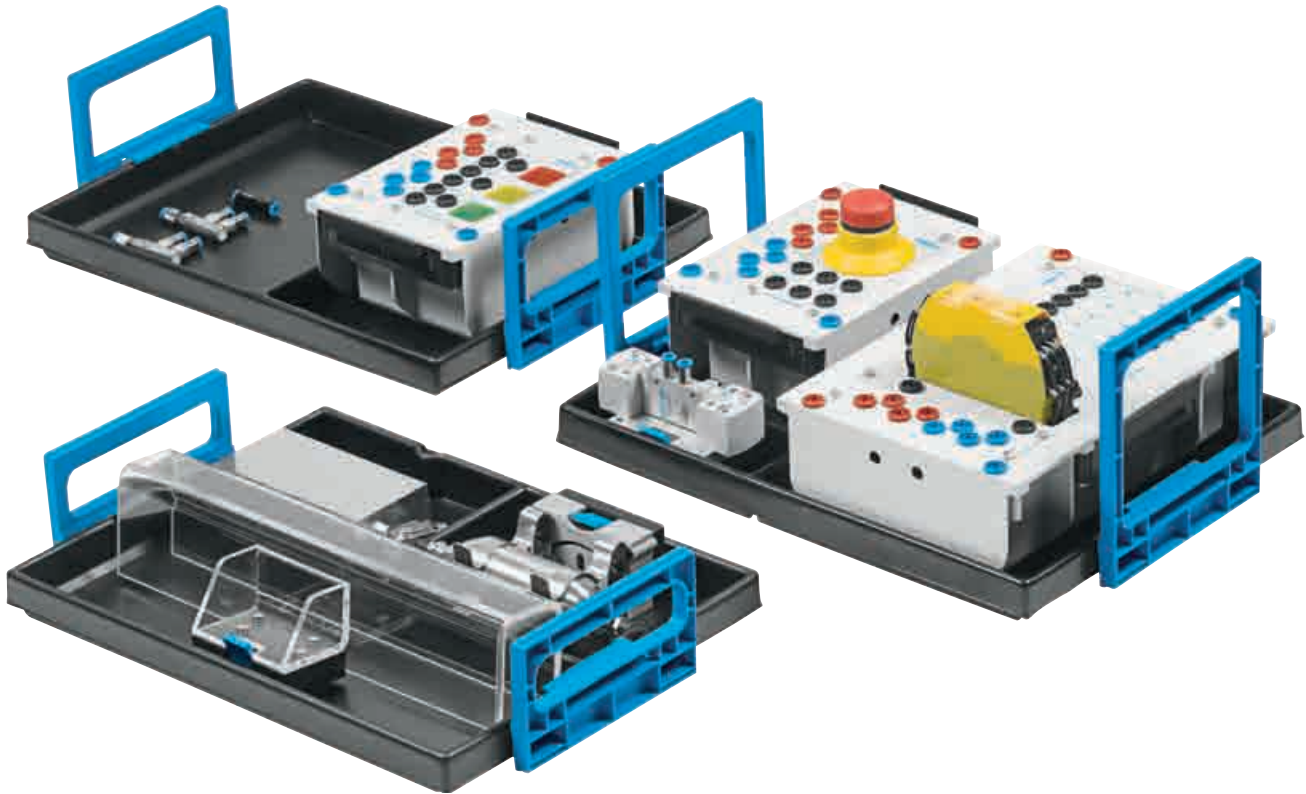

Risk reduction!

Just like good functionality and economic efficiency, safety is essential to the success of any product. What is more, new directives and laws require intelligent solutions and raise the level of professional skills required. As a result, there is a wide range of different products, information, and qualifications for safety engineering. However, most of these focus on the control level, meaning that safety usually only goes as far as the output of a fail-safe PLC, for example. However, risks can also arise outside of the power section, so it is important that systems include risk reduction measures to cope with such problems.

But what does the “pneumatics specialist” entrusted with the commissioning, troubleshooting, set-up, maintenance, and simple optimization of a system need to know? And how can this knowledge be conveyed in a clear manner, with easy-to-follow steps?

TP 250!

TP 250 builds on the training content of TP 101 and TP 201, focusing on the systematic optimization of safety in pneumatic systems. The aim of the training package is to detect risks in pneumatic processes, to assess the risks for a simple “machine”, and to learn what measures can be used to reduce risks and how to implement them properly.

Training content

- Reducing pressure and force according to the tasks
- Reducing the speed and acceleration while observing the cycle time and flow control for the specific loading conditions
- Emergency stop and release: suitable measures for stopping and properly recommissioning a pneumatic drive
- Suitable measures in case of compressed air failure and return, as well as instructions on how to store and use auxiliary energy
- Suitable measures in case of power failure and return
- Getting to know the operating modes and signals for operating statuses
- Using sensors to detect malfunctions
- Increasing the performance level using a dual-channel emergency stop system
- Selecting and using suitable protective measures

Components from equipment sets TP 101 and TP 201 are required to carry out the projects.

Mounting the pneumatic system, consisting of cylinders, weight, and cover, is done on the profile column of a Learnline workstation. If there is no profile column available, the mounting kit for Learntop S (order no. 526847) or the mounting kit for vertical slotted profile plates (order no. 533528) can be used. Two of each of these are needed.

Complete equipment set TP 250 in equipment tray **567264**

The most important components at a glance :

1	1x Air pressure reservoir, 0.1 l	573281
2	2x Non-return valve, delockable	540715
3	1x 5/3-way double solenoid valve, mid position closed	567201
4	1x Non-return valve	153462
5	1x Weight, 2 kg for cylinder	572778
6	1x Cover for cylinder	572777
7	1x Operational status display	567263
8	1x Mushroom-head safety switch	567261
9	1x Safety relay for emergency stop and safety door	567262

Necessary accessories, also order:

Aluminum profile plate → Page 39
Compressor → Page 136
Tabletop power supply unit → www.festo-didactic.com
Power supply unit for mounting frame → Page 159
4 mm Safety laboratory cables → Page 159

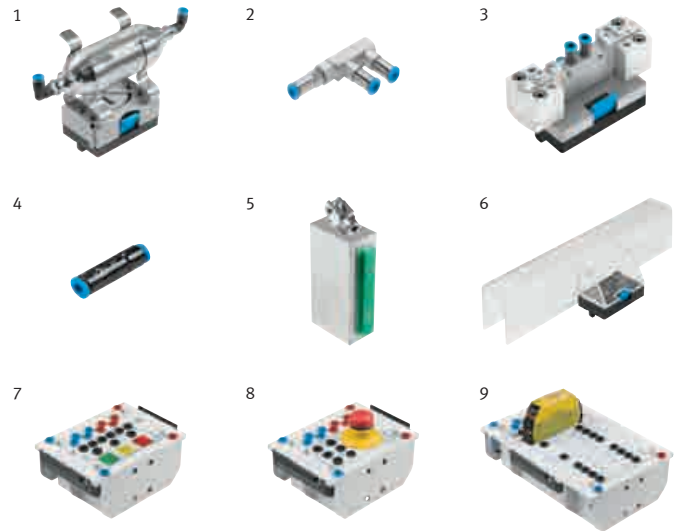

Also order:

Workbook

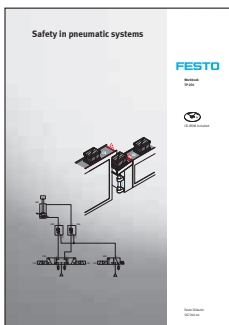

The workbook contains progressively complex project tasks, together with the solutions for each exercise sheet. In these exercises, students reduce the potential risk level of a pneumatic system step-by-step. The basic level contains the following topics: overview of relevant standards, laws, and regulations; overview and detailed description of operating modes; overview and detailed description of ten relevant safety functions; possible technical solutions for each safety function;

extensive illustrations and cross-sections to explain the design principles.

The workbook contains:

- Sample solutions
- Training notes
- Multimedia CD ROM with graphics and photos of industrial applications, safety guidelines, safety poster
- Worksheets for students

Campus license (→ Page 19):

de	567265
en	567266
es	567267
fr	567268

Supplementary media

- WBT Safety engineering
- WBT Pneumatics
- WBT Electropneumatics
- Designing and simulating with FluidSIM®
- Measuring and controlling with FluidLab®
- Textbook: Pneumatics/ electropneumatics
- Set of posters on pneumatics

Equipment set TP 260.v2 – Advanced level

Digitalization in pneumatics

New



Are you ready for digitalization?

Digitalization is transforming the working environment of many traditional industrial professions and trades. The expectations from the students and apprentices who are the future maintenance technicians are changing as a result.

By expanding the equipment set “TP 201 – basic level electropneumatics” with “TP 260 Digitalization in pneumatics”, you take this change into account in the curricula.

By completing 15 exercises in the work book using the hard ware, the students will be able to:

- understand the role of maintenance technicians in I4.0
- analyze and improve a basic machine towards digitalization
- choose the necessary sensors to collect digital data for condition monitoring
- analyze the digital data for predictive maintenance measures
- implement a networking system to receive the digital data

- implement a smart troubleshooting system
- improve the machine speed, machine availability, process reliability and production efficiency.

Using those practical examples from the field of maintenance, you prepare your students and apprentices for digitalization, smart maintenance and make them fit for the future.

The learning path at a glance

- A machine is designed, and production is realised.
- Brainstorming to improve the customer satisfaction and therefore, the machine.
- Necessary sensors and softwares are decided to get the support of digitalisation.
- Limit values are determined and appropriate information provided when these are not met or are exceeded.
- Using his/her mobile device, the operator/maintenance technician can receive up-to-date information on the system status via web service at any time.



- In the event of critical errors, the operator/maintenance technician is actively sent notifications to his/her smartphone, for example.
- To optimally prepare for the pending maintenance work, information stored in relation to error symptoms can be retrieved via the web service.
- Broken components are introduced without the notice of the students to make them apply smart maintenance.
- The effectiveness of communication between human and machine is tested and improved further.

What's new in TP 260.v2

- New controller Siemens S7/1200 with analog inputs and outputs for further PLC trainings
- Desktop PC with pre-installed TP260 software to be used as a server
- Grafcet as a step diagram
- New exercises to understand the need for digitalization and role playing to simulate a production environment
- Defective components to simulate breakdowns

Complete equipment set TP 260.v2 in equipment tray 8107242

The most important components at a glance :

1	1x Proportional pressure regulator with display	8108025
2	1x Flow sensor, 0,5 – 50 l/min, analog	8036235
3	1x Emergency stop pushbutton, electrical	183347
4	1x EduTrainer Compact preferred variants with SIMATIC S7-1200	8115009
5	1x Software Simatic Step 7 (TIA Portal) V15, de/en/es/fr	8107521
6	3x Ethernet cable, RJ45, CAT5	567280
7	1x Access point, Wi-Fi router	8086515
8	1x Mini Desktop PC	8107348
9	1x Double-acting cylinder, defective	5042759
10	2x Proximity sensor, electronic, with cylinder mounting	2344752
11	1x Filter sleeves for on-off valve with filter regulator, clogged	8064260
12	1x Socket strip for IEC power cable	8072997

Necessary accessories, also order:

2x IEC power cables → www.festo-didactic.com	
Aluminum profile plate → Page 39	
Compressor and compressor accessories → Page 136	
Power supply unit for mounting frame → Page 159	
4 mm Safety laboratory cables, 106 pieces, red, blue, and black	8092668



Also order:

Workbook



The workbook contains 15 project exercises where the relevant tasks for digitalizing a process, efficient operation and predictive maintenance are performed step by step.

The workbook contains:

- Basic elements
- Sample solutions
- Training notes
- Worksheets for students
- CD-ROM (contains a PDF of the workbook incl. worksheets)

Campus license (→ Page 19):

de	8111486
en	8111487
es	8111488
fr	8111489

Supplementary media

- Designing and simulating with FluidSIM®
- Measuring and controlling with FluidLab®
- Textbook: Pneumatics/ electropneumatics
- Set of posters on pneumatics

Notes:

Components from the TP 201 equipment set are required in order to complete the exercises.

If you want to use LOGO! controller version:

Complete equipment set TP 260.v1

Further information → www.festo-didactic.com



Complete equipment set TP 260.v1 in equipment tray 8083380

BIBB pneumatics equipment set

Suitable for BIBB pneumatics course

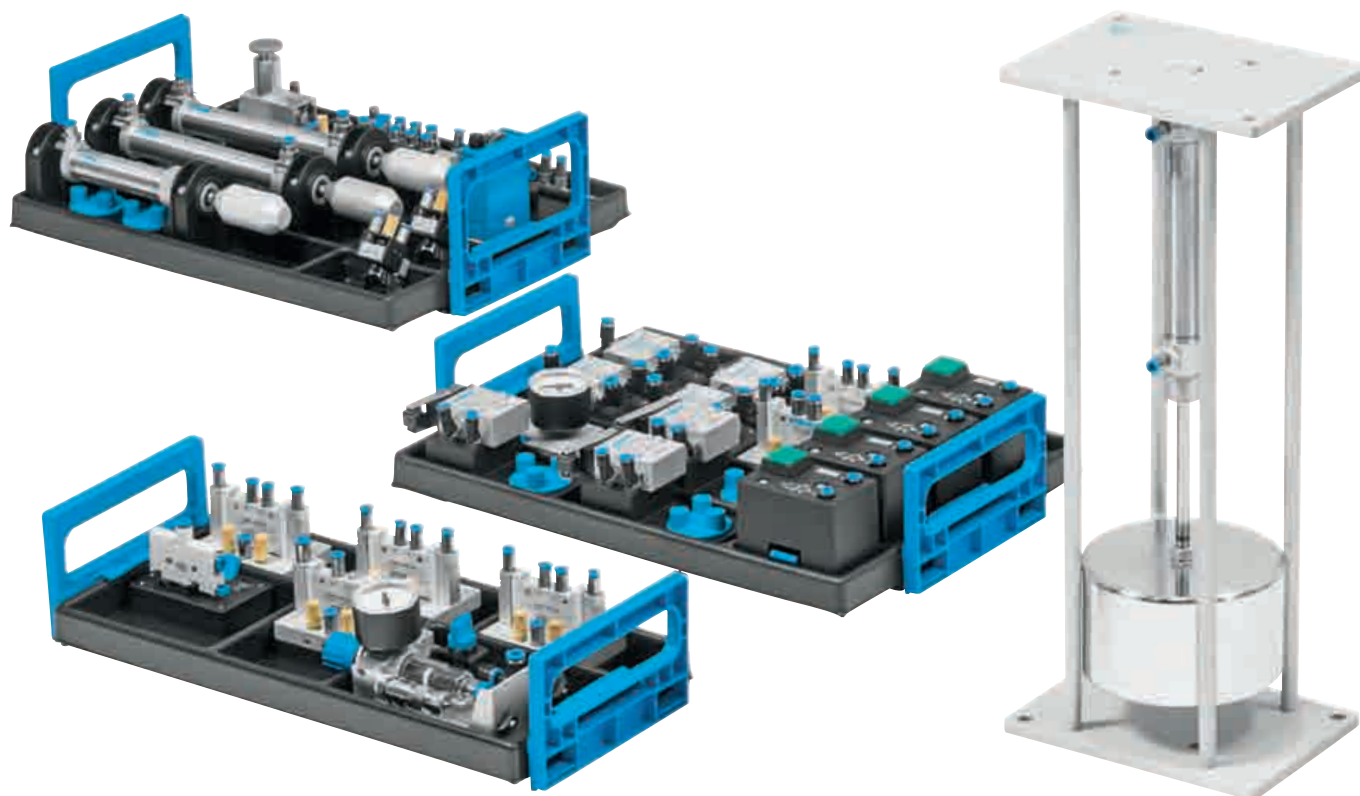

BIBB pneumatics 2007/2008

The new edition of the “Pneumatic control technology” training course is recommended and published by the Bundesinstitut für Berufsbildung (BIBB, German Federal Institute for Vocational Education and Training).

Festo Didactic offers the suitable equipment set for this course.

The 2007/2008 edition contains a few new additions compared with the 1999 edition:

- Piloted non-return valves to stop pneumatic drives in any position in case of a drop in pressure.
- Pneumatic proximity sensors as a modern alternative to roller lever valves for cylinder sensing.
- Getting started in vacuum technology: vacuum generation with a venturi nozzle/laval nozzle and simple handling with suction grippers.

The Festo Didactic Advantage

A CD-ROM complete with all circuit diagrams for all the exercises and activities is an integral part of the scope of delivery. These are in CT file format for FluidSIM® Pneumatics and in PDF file format.

It goes without saying that all equipment set components are compatible with the Festo Didactic training package components.

This means you can either supplement your TP 101 with the BIBB pneumatics equipment set or your BIBB pneumatics equipment set with the TP 101.

A wealth of information on the basic principles of pneumatics!

Also order:

Pneumatic control technology – exercises for trainees

Recommended and published by the Bundesinstitut für Berufsbildung (BIBB, German Federal Institute for Vocational Education and Training).

In addition to 11 exercises, which require the BIBB pneumatics equipment set, the following topics are also included:

- Compressed air generation
- Basic terms in control technology
- Servicing
- Maintenance
- Inspection
- Repair procedure
- Fault finding/analysis/documentation

Pneumatic control technology – exercises and solutions

Recommended and published by the Bundesinstitut für Berufsbildung (BIBB) (German Federal Institute for Vocational Education and Training).

The “Pneumatic control technology, exercises for trainees” book contains questions for trainees about the 11 exercises, as well as the solutions and circuit diagrams.

de 90090

de 90070

Complete equipment set BIBB pneumatics in equipment tray 549840

The most important components at a glance:

1	3x 3/2-way valve with pushbutton actuator, normally closed	152860
2	1x 3/2-way valve with pushbutton actuator, normally open	152861
3	3x 3/2-way roller lever valve, normally closed	152866
4	1x 3/2-way valve, pneumatically actuated at one end	576302
5	1x 5/2-way valve, pneumatically actuated at one end	576307
6	3x 5/2-way double pilot valve, pneumatically actuated at both ends	576303
7	1x 5/3-way valve, mid-position closed	576304
8	1x Pneumatic timer, normally closed	540694
9	1x Pressure sequence valve	152884
10	1x Shuttle valve (OR)	539771
11	3x Dual-pressure valve (AND)	539770
12	1x Quick-exhaust valve	539772
13	2x One-way flow control valve	193967
14	2x Non-return valve, delockable	540715
15	2x Proximity sensor, pneumatic, with cylinder attachment	2764815
16	1x Suction gripper, 10 mm diameter	560158
17	1x Vacuum generator	548628
18	1x Single-acting cylinder	152887
19	2x Double-acting cylinder	152888
20	1x Driving/tractive load	152889
21	1x Pressure gauge	152865
22	1x Start-up valve with filter control valve	540691
23	1x Manifold	152896
24	2x Plastic tubing, 4 x 0.75 silver 10 m	151496

Accessories, also order:

Aluminum profile plate → Page 39

Compressor → Page 136

Supplementary media

- WBT Pneumatics
- FluidSIM® Pneumatics design and simulation program
- Cutaway model case
- Set of posters on pneumatics
- Textbook: Pneumatics, Basic level
- Workbook: Pneumatics, Basic level TP 101
- Workbook: Pneumatics, Advanced level TP 102
- GRAFCET drawing template

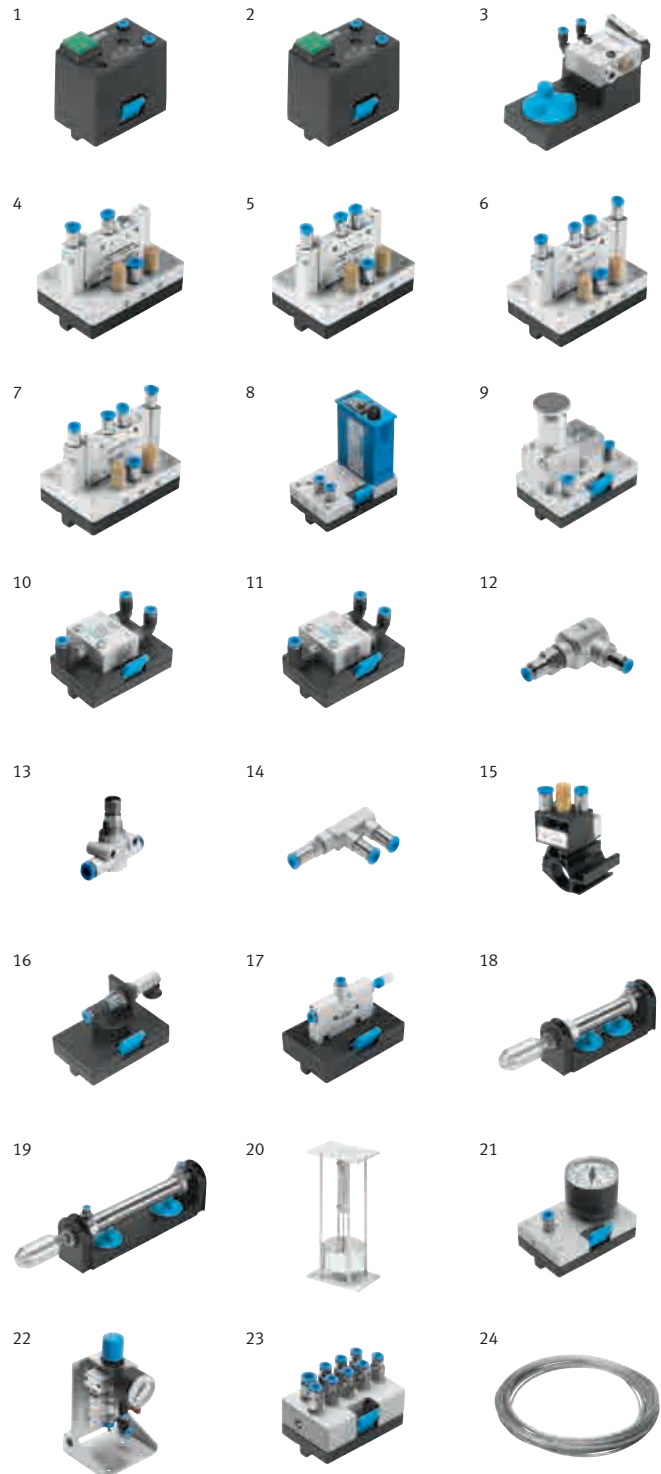

BIBB electropneumatics equipment set

Suitable for BIBB electropneumatics course

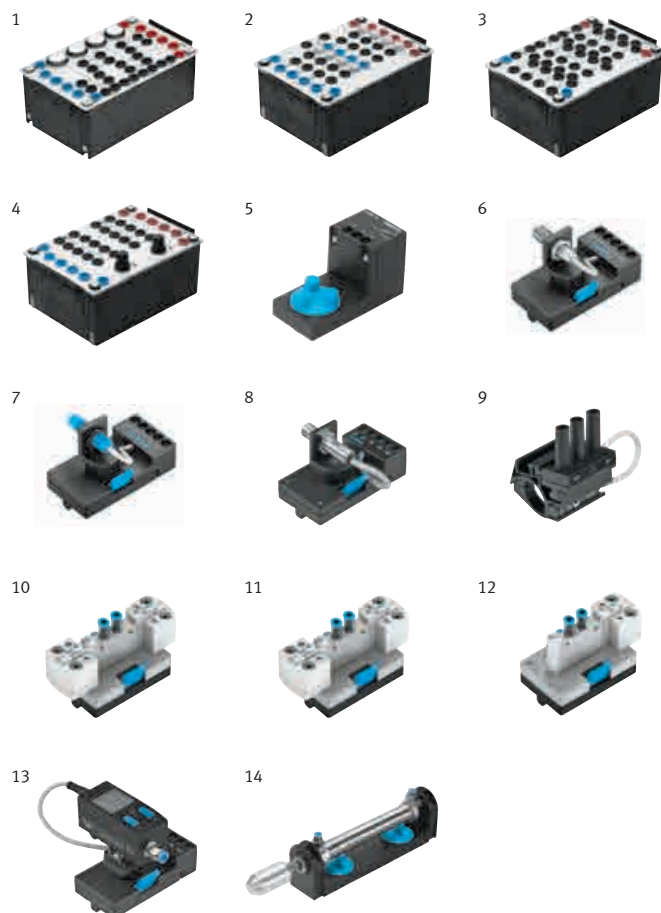

Complete equipment set BIBB Electropneumatics in equipment tray **184462**

The most important components at a glance:

1	2x Signal input, electrical	162242
2	1x Indicator unit and distributor, electrical	162244
3	2x Relay, three-fold	162241
4	1x Time relay, two-fold	162243
5	1x Limit switch, electrical, left-actuated	183322
6	1x Proximity sensor, inductive, M12	548643
7	1x Proximity sensor, capacitive, M12	548651
8	1x Proximity sensor, optical, M12	572744
9	2x Proximity sensor, electronic, with cylinder mounting	2344752
10	3x 5/2-way double solenoid valve with LED	567200
11	1x 2 x 3/2-way solenoid valve with LED, normally closed	567198
12	3x 5/2-way solenoid valve with LED	567199
13	1x Pressure sensor with display	572745
14	1x Double-acting cylinder	152888

Recommended accessories:

Aluminum profile plate → Page 39

Compressor → Page 136

Tabletop power supply unit → www.festo-didactic.com

Power supply unit for mounting frame → Page 159

4 mm Safety laboratory cables → Page 159

Training aims

- Physical fundamentals of electrics and pneumatics
- Function and application of electropneumatic devices
- Representing motion sequences and switching states
- Constructing control systems using relays
- Electrical latching circuits
- Using magnetic proximity sensors
- Using pressure switches
- Directionally dependent control systems using sensors
- Directionally dependent control systems using predetermining counters
- Controllers with parameters (e.g., single/continuous cycle, EMERGENCY-OFF)
- Step diagram controls/process-controlled sequence controls
- Timing controls/time-controlled sequence controls
- Program controls with non-deleting and deleting sequencer
- Troubleshooting large electropneumatic control systems

The selection of components complies with the German Federal Institute for Vocational Training (Bundesinstitute für Berufsbildung (BIBB)) course.

Recommended training media



- WBT Electropneumatics
- Design and simulation program, FluidSIM® Pneumatics

Also order:

BIBB Electropneumatics course

de **93070**

and:

Accompanying exercises, log sheets, and exercise circuits

de **93080**

Equipment set TP 111

Basic closed-loop pneumatics training

Complete equipment set TP 111 in equipment tray **184467**

The most important components at a glance:

1	1x Signal input, electrical	162242
2	2x 3/2-way valve with pushbutton actuator, normally closed	152860
3	1x 2 x 3/2-way solenoid valve with LED, normally closed	567198
4	1x Pressure gauge	152865
5	2x One-way flow control valve	193967
6	1x On-off valve with filter/regulator, 5 µm	526337
7	1x Manifold	152896
8	1x Plastic tubing, 4 x 0.75 silver 10 m	151496
9	1x PID controller	162254
10	1x Comparator	162257
11	1x Pressure sensor, analog	167094
12	1x 5/3-way solenoid valve, mid position closed	567201
13	1x 5/3-way proportional valve	167078
14	2x Air pressure reservoir, 0.4 l	152912
15	1x Status controller	162253
16	1x Linear drive, pneumatic, with guide and accessories	192501
17	1x Position encoder	152628
18	1x Ruler	525927
19	1x Weight, 5 kg, for linear drive	34065
20	2x Shock absorber	34572
	1x Connecting cable for linear potentiometer	376177
	1x Adapter for Y-axis or weight	167032
	1x Mounting accessories for position encoder	8065079

Recommended accessories:

Aluminum profile plate → Page 39	
Compressor → Page 136	
Digital multimeter	8040005
Digital storage oscilloscope	571845
Function generator	152918
Cable BNC – 4 mm	152919
Cable BNC – BNC	158357
T-connector BNC	159298
Tabletop power supply unit → www.festo-didactic.com	
Power supply unit for mounting frame → Page 159	
4 mm Safety laboratory cables → Page 159	

Training aims

- Controlling pressure and position
- Action sequence of a control circuit
- Activity and timing of control units: discontinuous and continuous controls, P, I, D, PI, PD, PID controls, status controls
- Behavior of control sequences: transfer characteristics, transient response, system with and without compensation, system of first, second and third order, idle times
- Interaction of closed-loop controls and control systems: control circuit optimization, stability considerations
- Set-up, commissioning, and optimization of closed-loop control assemblies, devices, and systems with analog controller cards

Recommended training media

- WBT Pneumatics
- Design and simulation program, FluidSIM® Pneumatics

Also order:

Workbook Closed-loop pneumatics

Campus license (→ Page 19):

de	94459
en	94465
es	533499
fr	94347

Partial equipment sets for controlling pressure and position on request.

Note: The linear drive and linear potentiometer are mounted perpendicular to the profile slot.

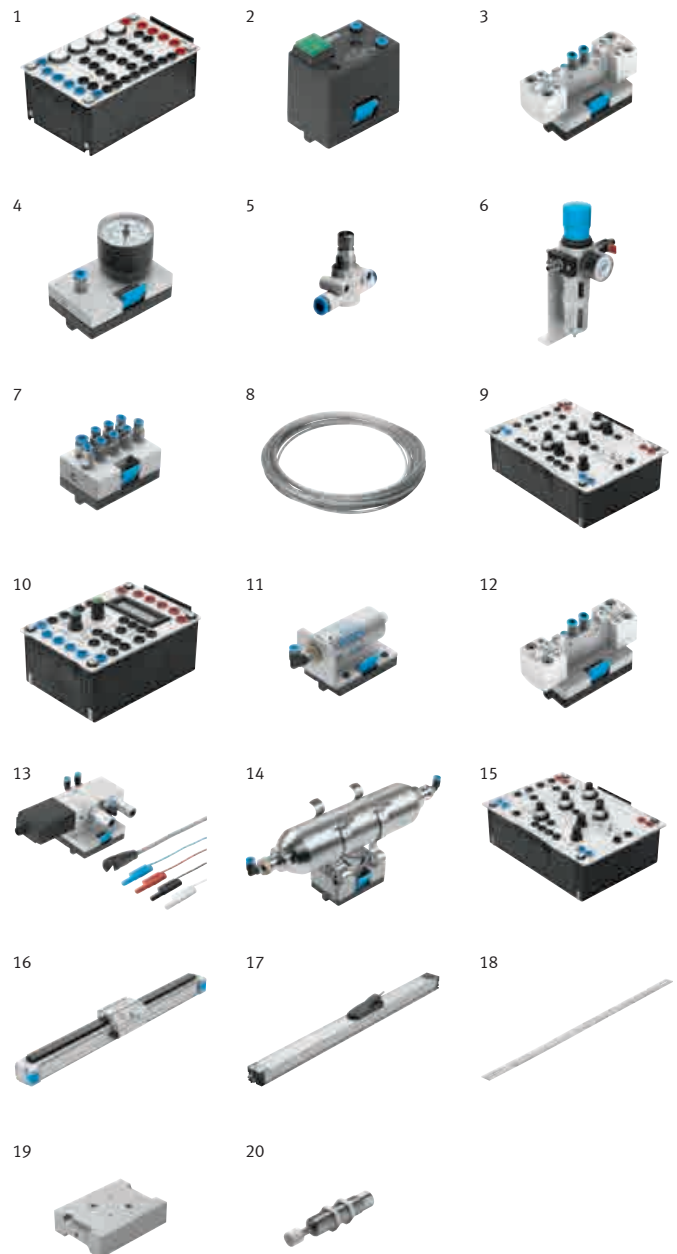

Air Control System AirCS® equipment set – Advanced level

Energy-efficient compressed air management



A view of the entire system

Before compressed air can be used it must be generated, purified, and distributed up to the respective application. Compressed air is a valuable form of energy. Nevertheless, too little is often done to lay out the overall system efficiently. Consumption is rarely measured or monitored. The cost situation is usually unclear.

This is where the Air Control System AirCS® comes in. The important aspects of making compressed air available and distributing it are examined within the framework of the AirCS® training project with regard to energy efficiency.

The AirCS® EduTrainer® serves as a basis to this end. It's incorporated between compressed air generation (compressor) and the process. In combination with FluidLab®-AirCS® software, integrated measuring technology allows for innovative condition monitoring for the measurement of compressed air and energy consumption.

Generation and load management

The index number of the connected compressor is ascertained under the Condition Monitoring menu item. Various compressors can be compared and changes can be detected at an early stage. A calculation tool assists the user in ascertaining overall variable and fixed costs for compressed air generation.

In the case of load management, energy consumption is visualized for the compressor and an additional consuming device. Pressure thresholds are specified for switching the compressor on and off. In consideration of peak loads, the fundamentals of load management can then be imparted and tested.

As a prerequisite for the use of AirCS®, a system must be available for measurement, for example the MPS® distributing station or the equipment set TP 201 (basic level electro-pneumatics).

Distribution and monitoring

Long-term monitoring makes it possible to visualize consumption for individual applications. This allows for well-founded statements regarding energy costs. Targeted and actual statuses can be compared, for example, in order to be able to detect and evaluate leaks.

Compressed air distribution components can be examined in the Flow Resistance menu. In this way, for example, the various resistances of different tubing lengths and diameters can be acquired and compared, as well as for T-connectors and elbow connectors. Furthermore, a calculation tool is available for determining the ideal pipe cross-section.

In the case of nominal flow measurement, a second, external pressure sensor can be used to ascertain the nominal flow rates of devices and components, in a manner similar to the ISO 6358 standard.

Special features of the AirCS® EduTrainer®

Pneumatic function area with:

- Flow sensor
- Pressure sensor
- Distributor block for QS-4/6/8
- Directly actuated 5/2-way solenoid valve
- Outlet with flow control valve and stop-cock

Electrical function area with:

- Energy consumption meter
- 2x 230/110 V AC outputs with control technology to switch the 230/110 V AC consuming devices
- SysLink and analog connection for EasyPort
- Connections for integrating the external sensor

Can be used for A4 mounting frame (399 x 297 mm) or as table stand.

Complete equipment set AirCS 8023858

The most important components at a glance:

1x AirCS EduTrainer	8023859
1x AirCS accessory kit	8023860
1x FluidLab-AirCS 1.0 single license	8023861
1x EasyPort USB	548687
1x Analog cable, parallel, 2 m	529141
1x I/O data cable with SysLink connectors (IEEE 488) at both ends, 2.5 m	34031
1x Pressure sensor with display	572745

Necessary accessories, also order:

Compressor → Page 136
Tabletop power supply unit → www.festo-didactic.com
Power supply unit for mounting frame → Page 159
4 mm Safety laboratory cables → Page 159

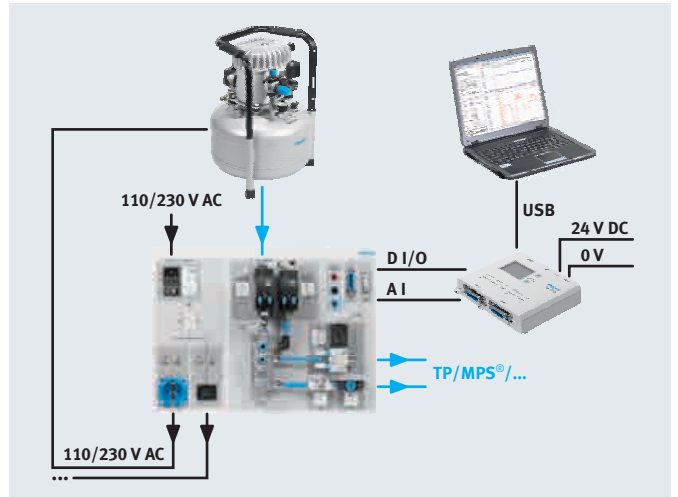

FluidLab®-AirCS® included

The FluidLab®-AirCS® software is an important component of the AirCS® equipment set. Just a few simple steps are needed to configure the interface and select the user language (German/English). Then the exercises can be started.

Exercises are supported by connection diagrams, descriptions, and sample solutions taken from the AirCS® workbook. The measurement process is software-controlled. Results can be measured with measuring points, printed out, or exported to a spreadsheet program. The software scope also includes the complete book of exercises in PDF format.

System requirements

- PC with Windows 7/8/10
- CD-ROM drive
- USB 2.0 or serial interface

AirCS® training documentation

The workbook in German and English constitutes the accompanying documentation for the AirCS® training project.

- The workbook contains:
- Definition of task
 - Sample solutions
 - Training notes

Up to two electric consuming devices (e.g. compressor and power supply unit) are needed to perform the load management exercises.



Equipment set TP 1311

Sensors for object detection

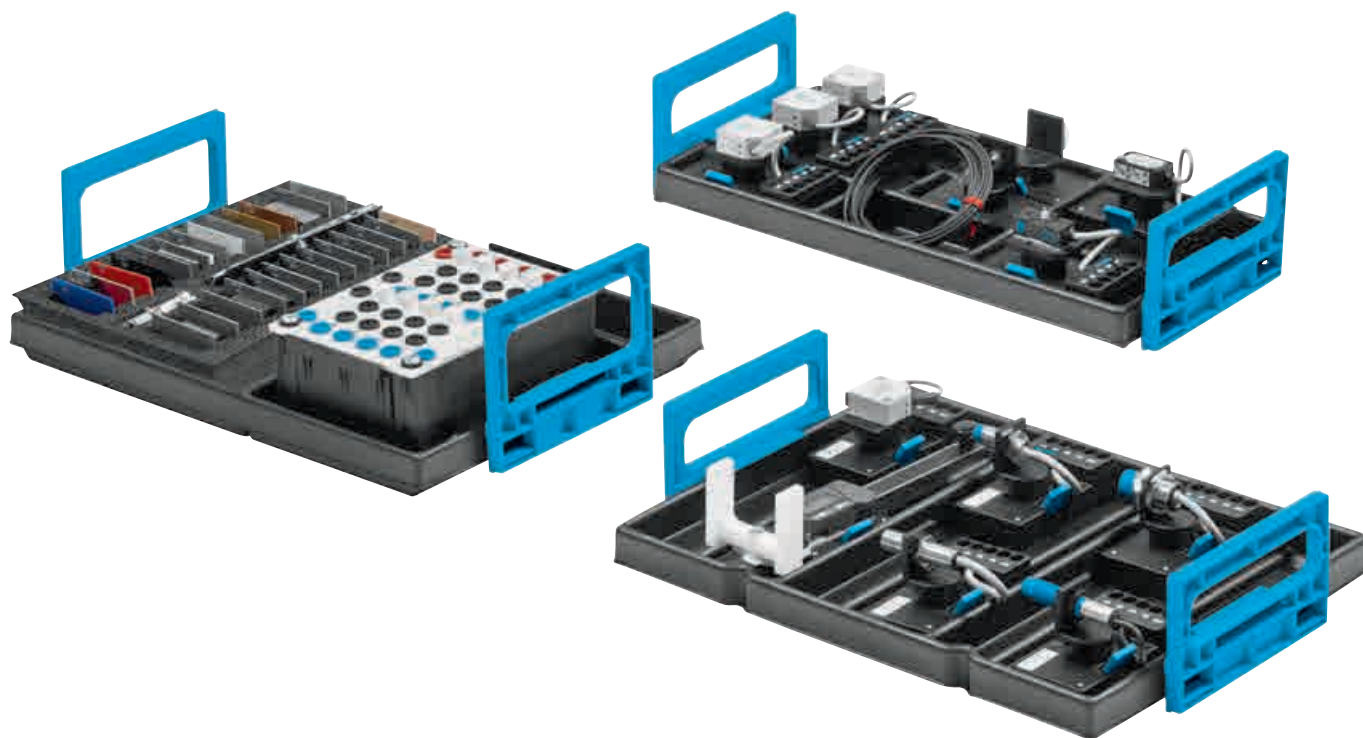

The purpose of automation technology

The subject of sensors for object detection is covered extensively in the TP 1311 equipment set. The topics include configuration, function, areas of application, and the selection of sensors based on the requirements of an application.

The equipment set contains sensors with analog and binary output signals, although the focus is on binary output signals. These sensors are called proximity switches.

The following types are contained in the equipment set:

- Magnetic proximity sensors
- Inductive proximity sensors
- Optical proximity sensors
- Capacitive proximity sensors
- Inductive sensors (analog)

The special feature

Hands-on experience plays a central role in teaching the fundamentals of sensors for object detection.

Examples are used to demonstrate the general operational principles of different sensors. Special attention is paid to the selection of the right sensor, its connection, the correct setting, and functional checking.

With the TP 1311 students can acquire a thorough, basic knowledge about sensors for object detection.

Course topics

- Configuration, function, and coefficients of the sensors used
- Basic principles of connection and circuit technology
- Influence of object shape, material, surface, and color on the switching characteristics of sensors
- Terms which describe coefficients and functional behavior
- Configuration of logic circuits
- Selecting appropriate sensors by taking into account certain parameters

Complete equipment set TP 1311 566918

The most important components at a glance:

1	1x Proximity sensor, magneto-resistive	566199
2	1x Proximity sensor, inductive, M12	548643
3	1x Proximity sensor, inductive, M18	548645
4	1x Analog sensor, inductive, M12	548644
5	1x One-way light barrier, receiver	548647
6	1x One-way light barrier, transmitter	548648
7	1x Fiber-optic unit	548655
8	1x Fiber-optic cable	548659
9	1x Retro-reflective sensor	548649
10	1x Reflector (triple mirror), 20 mm	548650
11	1x Diffuse sensor with background suppression	548656
12	1x Proximity sensor, capacitive, M12	548651
13	1x Indicator unit and distributor, electrical	162244
14	1x Slide unit	572740
15	1x Set of test objects	549830

Accessories, also order:

- Aluminum profile plate → Page 39
- Slotted mounting plate → Page 39
- Tabletop power supply unit → www.festo-didactic.com
- Power supply unit for mounting frame → Page 159
- 4 mm Safety laboratory cables → Page 159

Also order:

Workbook



The content topics are covered by exercises using magnetic, inductive, optical, and capacitive proximity sensors.

- The workbook includes:
- Sample solutions
 - Training notes
 - Multimedia CD-ROM with graphics, photos of industrial applications
 - Exercise sheets for trainees

Campus license (→ Page 19):

de	566919
en	566920
es	566921
fr	566922

Fifteen projects based on industrial examples, suitable for equipment set TP 1311, each including problem descriptions, parameters, and project tasks, deal in detail with the specific subject of sensors for object detection. The main topics are configuration, function, and the influence of material properties on behavior, possible applications, and how to select a sensor based on the application conditions.

Supplementary media

- WBT Sensor technology 2: Sensors for object detection
- Textbook: Proximity switches

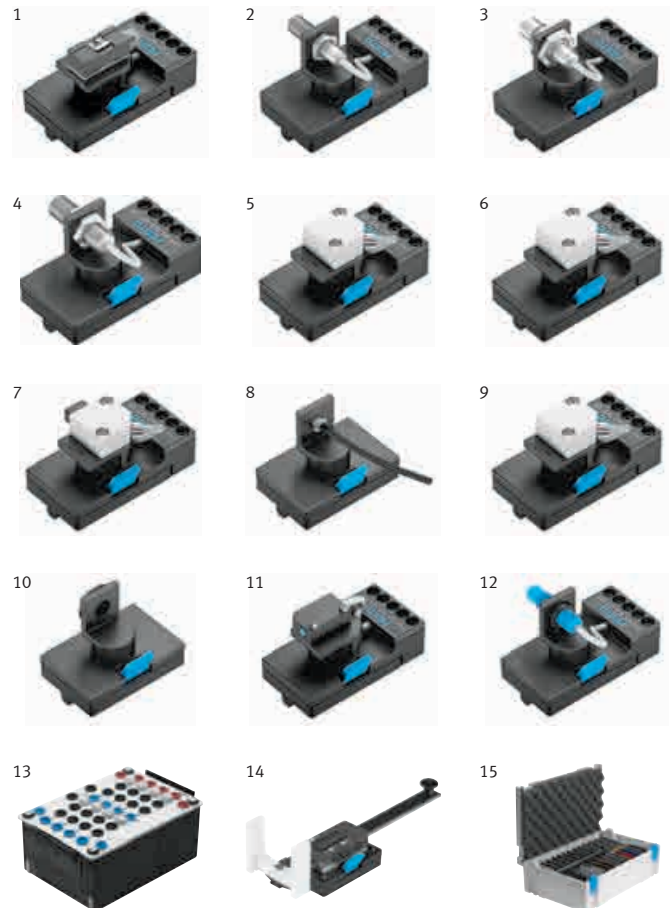

Hydraulics training packages

Tailored training in industrial and mobile hydraulics

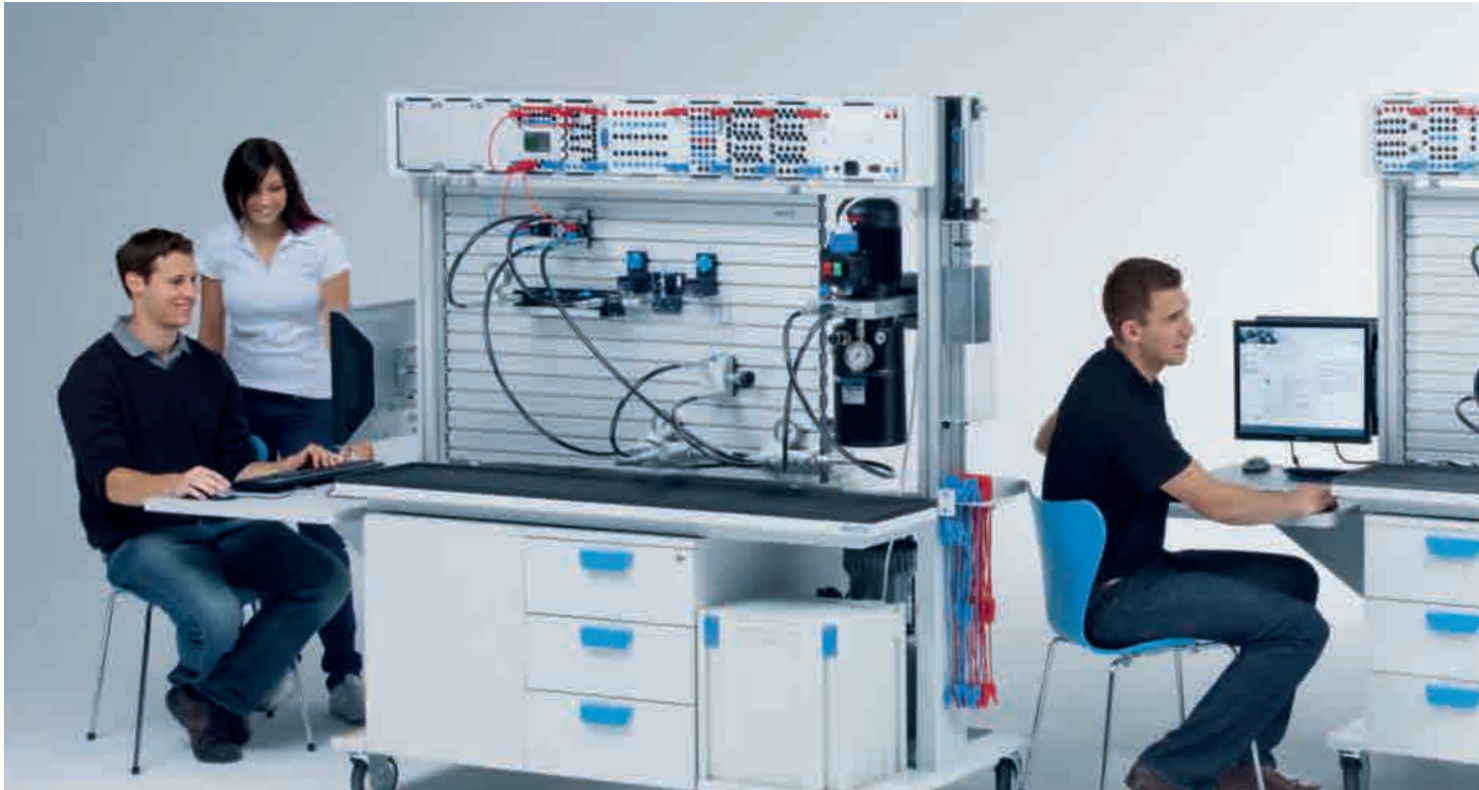

Modular for flexible expansion

Festo Didactic's training packages are modular in structure. For example, you could start with the basic level of electrohydraulics and then move onto the advanced level. Or are you more interested in electropneumatics? The choice is yours. You'd like to explore a particular specialised topic? All equipment set components can also be ordered separately, so you can turn your own ideas into reality.

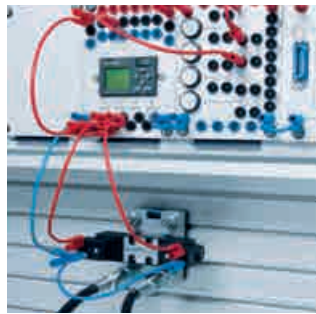

Position it – clamp it – done!

With the Quick-Fix mounting system, you can mount all components easily and securely on the profile plate or on the profile column of a Learnline workstation. The electrical units are clamped into the ER frame and sequenced individually. The supports and the electrical units are the same for both hydraulics and pneumatics – a single investment, with double the functionality.



Everything where you want it – systematic storage

Most equipment sets are delivered in practical, Systainer-compatible equipment trays. This equipment tray fits in the drawers of the workstations. The large pictogram on the components, designed in accordance with the latest standards, provides clear instructions for connecting the components and ensures short preparation and follow-up times. When dismantling circuits, you can quickly and easily locate where the component goes in the equipment tray.



Connect it – power!

Hydraulic power is supplied by the tool-free connection of low-leakage couplings – the latest generation in high-grade stainless steel. The coupling is self-sealing when uncoupled. During the low-friction coupling procedure, only the front surface is coated with oil, which saves resources, is easy on the environment, and reduces contamination.

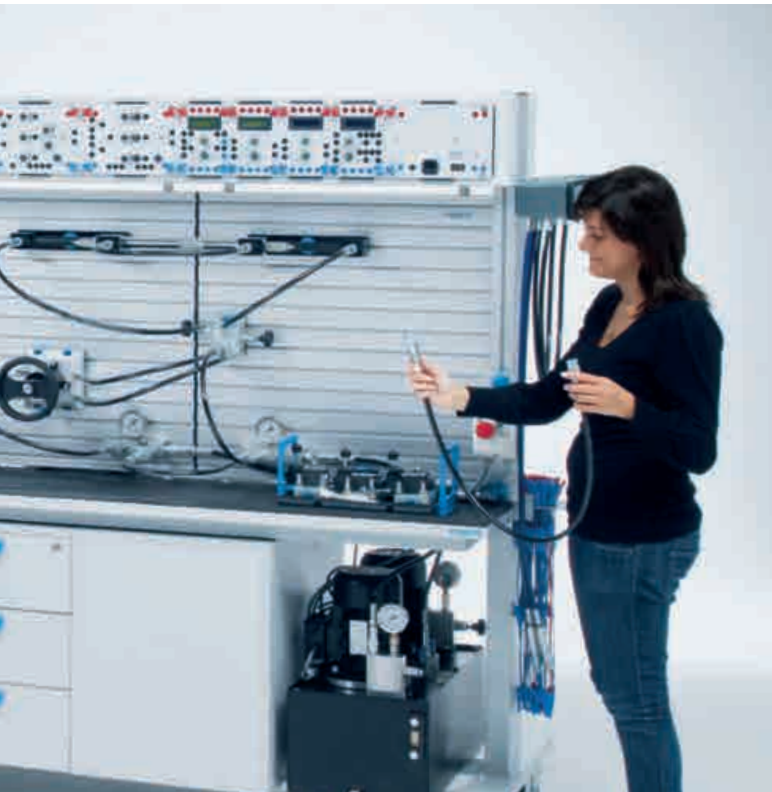

Didactic plus

The workbooks accompanying the training packages contain project-oriented exercises of increasing complexity. There are also positional sketches, illustrations, videos, animations, and cross-sectional drawings, which explain how things look in the real world. For a complete and expert treatment of the topic of hydraulics, the training also covers basic physics, technical calculations, safety, efficiency, analytical fault-finding, and professional documentation.

Hands-on basic and specialized training using industrial components provides the confidence to apply the acquired knowledge in the workplace. The components are specially selected for the exercises in the workbook. Note: nearly all hydraulic and electrical connections are located on the easily accessible upper side of the components.



Your choice of training environment

User-friendly training environments for specific topic areas:

- Self-study phases with the training programs
- Designing and documentation with FluidSIM®
- Hands-on experimentation with the training packages and the exercises in the workbooks
- Functional testing and optimization with measurement technology and FluidLab®



Quality not quantity!

Bigger is not necessarily better. Volumetric flow rates and pressures should be chosen with care and in coordination with the system as a whole. This especially applies to hydraulic training systems. High forces and cylinder speeds not only increase the danger for the user, but also require a larger hydraulic power pack with higher power consumption. So our offer is: as large as necessary and as small as possible, without compromising on teaching effectiveness.



New technologies – new skills needed

Modern measurement and diagnostic technology and cartridge valves are among the international trends in hydraulics. So you'll find those technologies in our learning systems as well. Benefit from the compact, integrated design, the low weight, ease of handling, and easy-to-read symbol system.



Mobile hydraulics

The new training packages for mobile hydraulics systematically and informatively explore complex topics and systems, such as work hydraulics, hydrostatic steering and drive systems for the agricultural, forestry, and construction vehicle sectors, and warehouse and municipal vehicles.

Equipment set TP 501 – Basic Level

Basic training in hydraulics

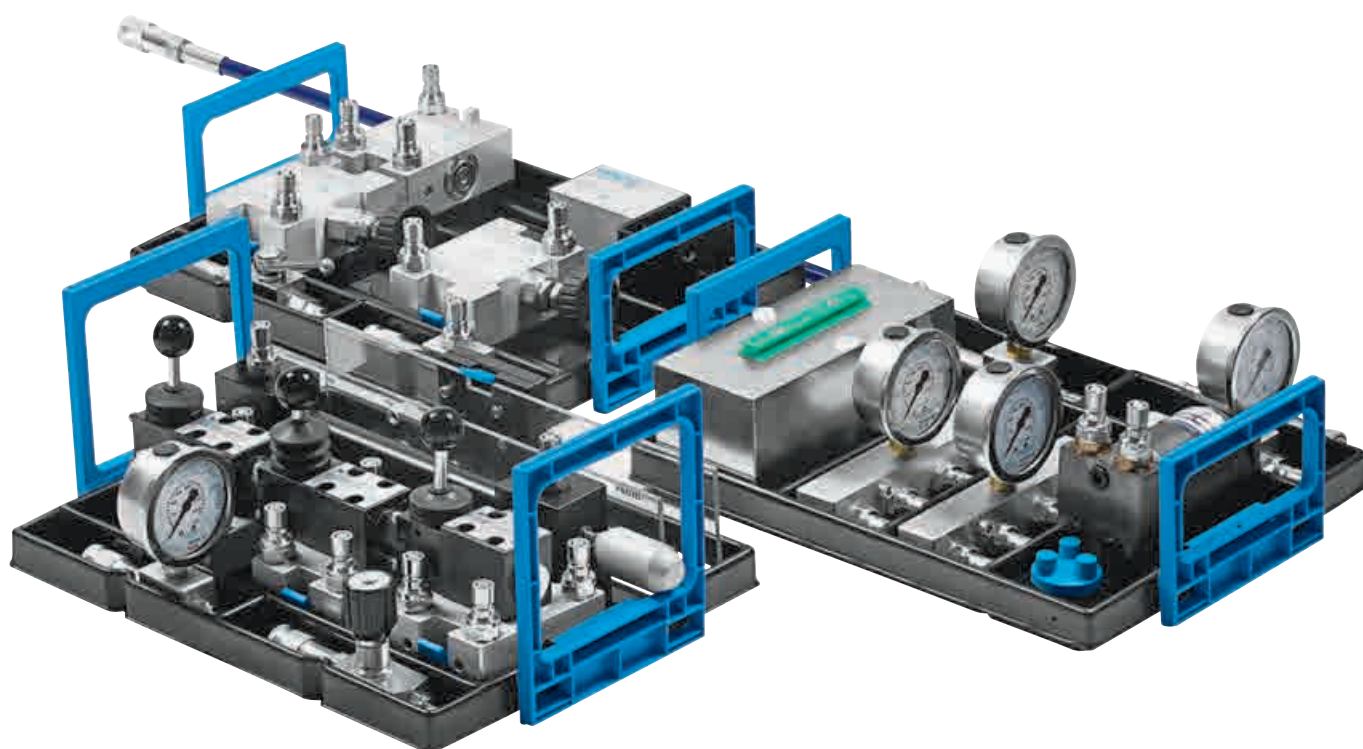

The classic reissued

The solid basis for hands-on basic and specialized education. Training package TP 501 contains only purely hydraulic control systems.

The number and version of the components are specifically adapted to the projects in the workbook. This is a cost-effective way of achieving the important training objectives.

TP 501, Basic Level is suitable for basic training in hydraulic control technology and imparts knowledge of the basic physical principles of hydraulics, as well as the function and use of hydraulic components.

Pure convenience

- Easy and exact switching of hand lever valves
- Ergonomic handwheels and fine resolution allow the simple and precise setting of the flow and pressure valves
- Tool-free, single-hand operation with quick action mounting system, Quick-Fix
- Easy and secure plugging and releasing of the new, low-leakage, self-sealing, quick connection couplings

Delivered in practical, Systainer-compatible equipment trays. The trays, in turn, fit exactly into the drawers in Learnline workstations.

Training content

Power packs and components:

- Design, function, and most important characteristics of a hydraulic power unit
- Design and function of pressure-relief valves, cylinders, and directional control valves
- Design and function of the non-return valve, one-way flow control valve, and piloted non-return valve
- Design and function of flow control valves

Measurements and calculations:

- Recording and interpreting the characteristic curve of a hydraulic pump
- Measuring the volume flow of a hydraulic control system
- Recording the characteristic curve of a pressure-relief valve
- Identifying and calculating times, pressures and forces during advancing and retracting of a cylinder
- Recording the characteristic curve of a flow control valve
- Calculating performance ratios when using 4/3-way valves with different mid-positions

Hydraulic circuits:

- Commissioning hydraulic circuits safely
- Using the flow control valve in the inflow and outflow and adjusting the drive speed
- Difference between a flow control valve and one-way flow control valve in hydraulic control systems
- Design and mode of operation of a differential circuit
- Effect of the piston surfaces on pressures, forces, speeds, and travel times
- Proper use of piloted non-return valves
- Circuits with different types of counter pressure
- Operating cylinders with varying loads

Complete equipment set TP 501 in equipment tray 573035

The most important components at a glance:

1	1x Pressure relief valve	544335
2	1x 2-way flow control valve	544338
3	1x One-way flow control valve	152843
4	1x Non-return valve, delockable	544339
5	1x Non-return valve, 0.6 MPa opening pressure	548618
6	1x 4/2-way hand lever valve, spring return	544342
7	1x 4/3-way hand lever valve, relieving mid-position (AB → T), detenting	544344
8	1x 4/3-way hand lever valve, closed mid-position, detenting	544343
9	1x Shut-off valve	152844
10	1x Differential cylinder 16/10/200 with cover	572746
11	1x Weight, 9 kg for cylinder	152972
12	1x Hydraulic motor	152858
13	1x T-distributor	152847
14	2x 4-way distributor with pressure gauge	159395
15	3x Pressure gauge	152841
16	1x Flow sensor	567191

Necessary accessories, also order:

7x	Hose line with quick release couplings, 600 mm	152960
3x	Hose line with quick release couplings, 1000 mm	152970
2x	Hose line with quick release couplings, 1500 mm	159386
	Digital multimeter	8040005
	Aluminum profile plate → Page 39	
	Hydraulic power pack → Pages 148 – 149	
	Protective cover for weight, 9 kg → Page 143	
	Power supply unit for mounting frame → Page 155	

Also order:

Workbook

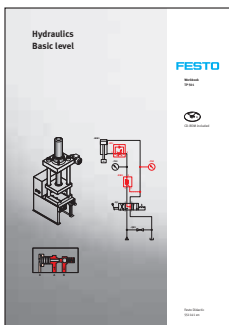

The basic circuits for hydraulics are presented in 17 exercises. The symbols used in the circuit diagrams are according to DIN/ISO 1219. In order to carry out the exercises, students require the equipment set for TP 501 Hydraulics, Basic Level.

The workbook contains:

- Sample solutions
- Training notes
- Multimedia CD-ROM with graphics, photos of industrial applications, animations, and FluidSIM® circuit diagrams
- Worksheets for students

Campus license (→ Page 19):

de	550141
en	551141
es	551145
fr	551146

Supplementary media

- Designing and simulating with FluidSIM®
- Measuring and controlling with FluidLab®
- WBT Hydraulics
- Textbook: Basic Principles of Hydraulics and Electrohydraulics
- Hydraulics poster set

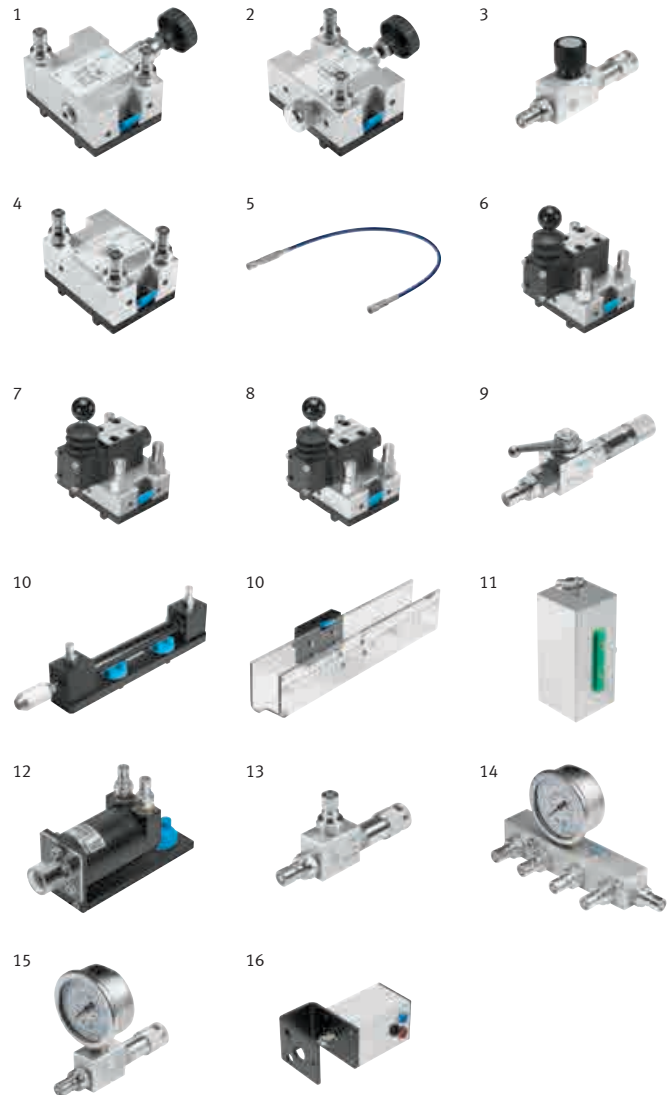

Equipment set TP 501+ – Advanced level

Systematic troubleshooting

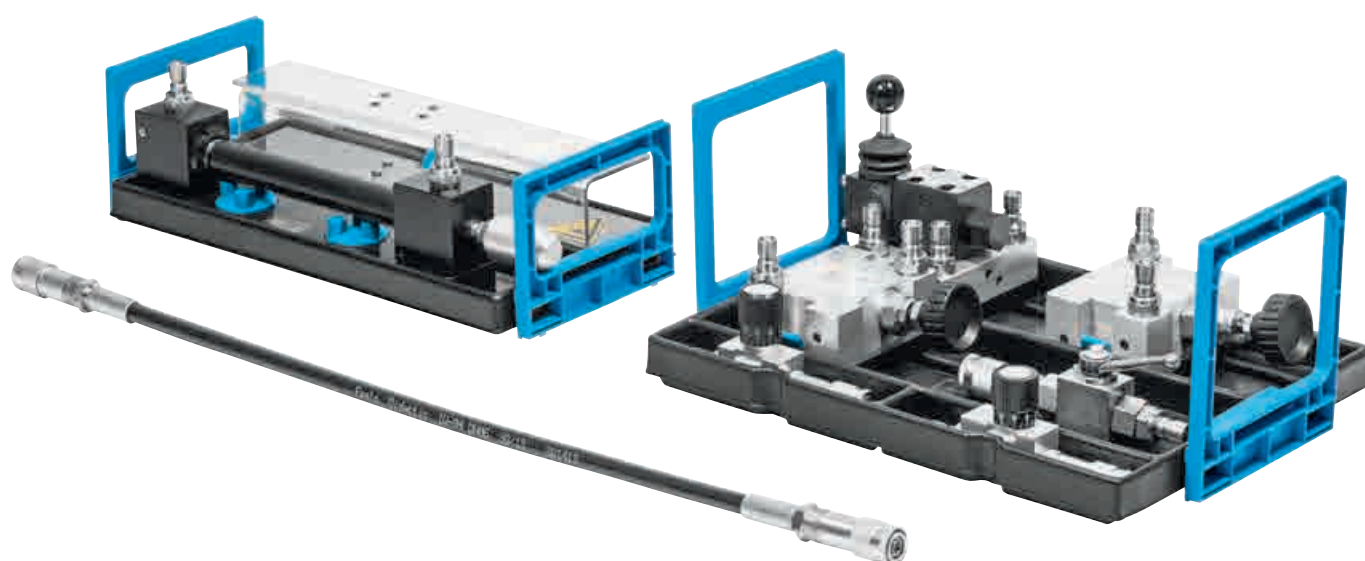

Realistic

Equipment set TP 501+ from Festo Didactic is an extension to equipment set TP 501. TP 501+ contains components with specified, realistic defects. It enables hydraulic circuits to be constructed with the TP 501 and individual components to be replaced by defective ones.

Using our experience in industrial environments, we were able to define typical error patterns for hydraulic systems and adapt them to the components contained in equipment set TP 501+.

Professional

Systematic troubleshooting and professional error elimination are an essential part of everyday operations in many jobs in the fields of mechanics, mechatronics, and electrical engineering. In order to acquire skills in this area via a structured, yet safe, procedure, it is important that systematic troubleshooting is both learned and practiced. Keys to this are:

- Understanding circuits and discerning any non-conformities
- Delimiting/precluding any error areas
- Locating and rectifying errors

This procedure assumes specialist knowledge, such as modes of operation of individual components and their system limits

Pressure relief valve with broken spring

One example of a defective component is a pressure relief valve with a broken spring. This defect may be due to a continuous load or a material flaw. The defect results in the spring length being shortened and hence, in a reduction in the maximum pressure that can be set. The conspicuous symptoms result in a lower cylinder force. Pressure sensors or force sensors may not switch, which can lead to interruptions to operation cycles or process safety being put at risk.

Flow control valve with damaged pressure compensator

Another example of a defect is a two-way flow control valve with a damaged pressure compensator. While intact, the valve ensures a constant volumetric flow rate, regardless of the load pressure. However, in this case, the pressure compensator is not working. The differential pressure is no longer being regulated via the throttle valve. Here, the flow control valve behaves like an unregulated throttle valve. A fault like this occurs if dirt has entered the system and as a result, the pressure compensator's piston has seized up in the open position.

Complete equipment set TP 501+ in equipment tray **8060229**

The most important components at a glance:

1	1x Shut-off valve, defective	8065301
2	1x One-way flow control valve, defective	8065298
3	1x Pressure relief valve, defective	8065175
4	1x 2-way flow control valve, defective	8065174
5	1x 4/3-way hand lever valve, H-center position, detenting (PTAB)	8065281
6	1x Flow control valve	152842
7	1x Differential cylinder 16/10/200, defective	8065195
8	1x Hose line with quick release couplings, clogged	8065327

Necessary accessories, also order:

Aluminum profile plate → Page 39

Hydraulic power pack → Pages 148 – 149

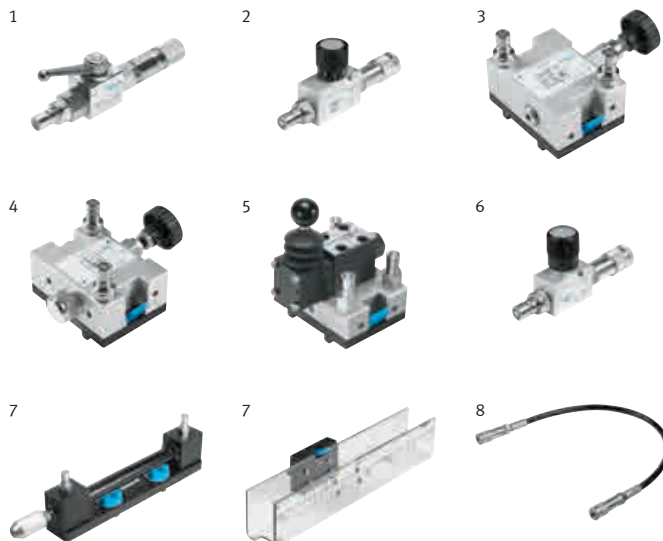

Requirements

Building on from Basic Level Hydraulics, the Advanced Level contains eight components appropriate for equipment set TP 501. Possible troubleshooting tasks are aimed at all job areas involving maintenance and repair activities. Special measuring equipment is not required since all symptoms are observable. However, error patterns can also be quantified using measuring equipment such as a flowmeter or pressure gauge.

Study materials

A description is included for each defective component describing both its function and the fault. A flow chart, which guides learners systematically from observation of the symptom to the repair task, is also included.

Supplementary media

- Design and simulation using FluidSIM®
- Diagnostic system TP 810 with FluidLab®-M
- Textbook: Basic principles of hydraulics and electrohydraulics
- WBT hydraulics
- Web-based training, electrohydraulics
- Hydraulics poster set



Equipment set TP 502 – Advanced Level

Hydraulics for advanced users

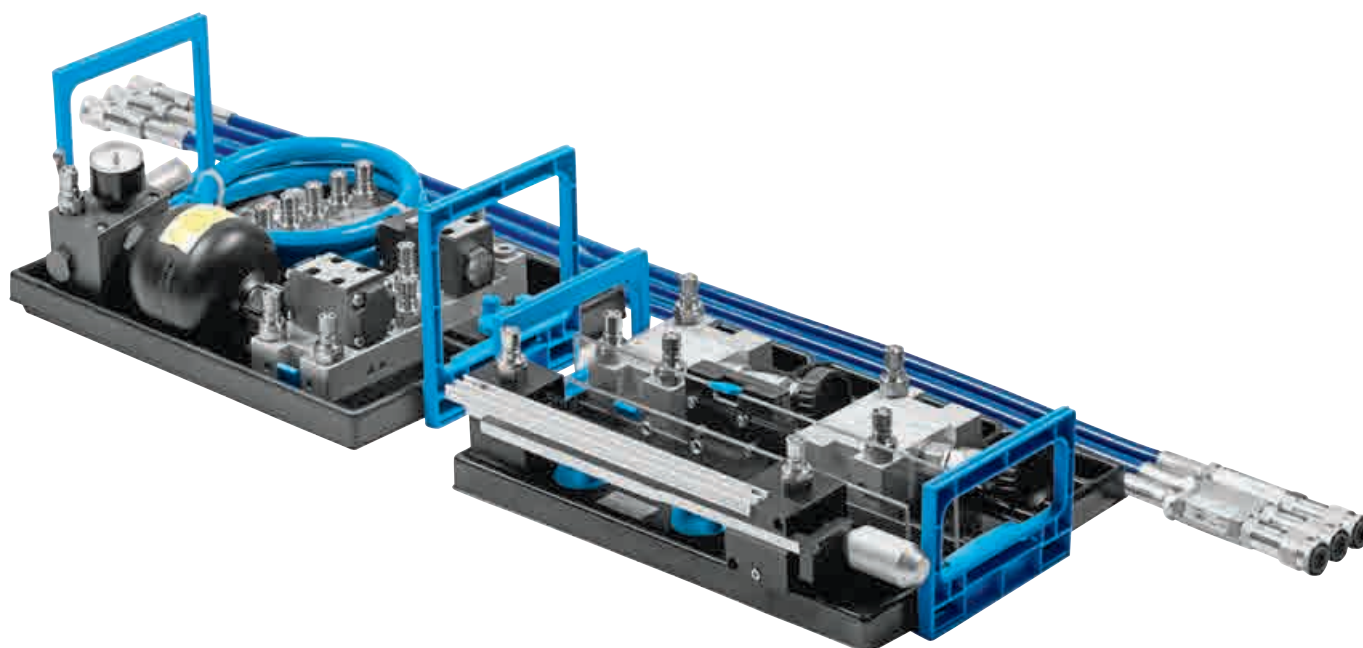

The new advanced level

The training package TP 502 builds on the material covered in training package TP 501 – Basic Level, and adds 15 new projects to it.

The course expands students' knowledge about the basic physical principles of hydraulics and the function and use of further hydraulic components.

In order to carry out the projects, users require the components and the necessary accessories from equipment set TP 501.

Hydraulics plus!

The new components provide added training value, and relevant project tasks form the basis for advanced training in fundamental principles.

Delivered in practical, Systainer-compatible equipment trays, which in turn, fit exactly into the drawers in Learnline workstations.

Training content

Power packs and components:

- Design and function of a hydraulic motor
- Setting the direction and rotation speed of a hydraulic motor
- Design, function, and use of a flow divider
- Using a hydraulic reservoir as a volume and pressure accumulator
- Design, function and use of a pressure regulator
- Specifying the cylinder pressure
- Difference between pressure-relief valves and pressure regulators

Measurements and calculations:

- Calculating performance ratios of hydraulic circuits from measured values
- Calculating forces on the cylinder
- Creating procedure descriptions

Hydraulic circuits:

- Implementing bypass circuits
- Ensuring synchronized forward and return strokes
- Getting to know the bypass circuit
- Getting to know the rapid traverse feed circuit
- Advancing and retracting of a cylinder after the pump from the reservoir is switched off
- Use of a hydraulic reservoir for a rapid traverse circuit
- Getting to know the rectifier circuit
- Configuration and description of a sequence control with two cylinders
- Getting to know the pressure sequence and pressure stage circuit
- Getting to know the fuse protection for tensile loads

Complete equipment set TP 502 in equipment tray 573036

The most important components at a glance:

1	1x Pressure relief valve, compensated	567237
2	1x 3-way pressure reducing valve	544337
3	1x Flow dividing valve	544340
4	1x 2/2-way stem actuated valve, convertible	544353
5	3x Non-return valve, 0.6 MPa opening pressure	548618
6	1x Diaphragm accumulator with shut-off block	152859
7	1x Differential cylinder 16/10/200 with cover	572746
8	1x Mounting kit for cylinders	544371
9	5x T-distributor	152847

Necessary accessories, also order:

7x	Hose line with quick release couplings, 600 mm	152960
4x	Hose line with quick release couplings, 1000 mm	152970
2x	Hose line with quick release couplings, 1500 mm	159386
	4 mm Safety laboratory cables → Page 155	
	Digital multimeter	8040005
	Aluminum profile plate → Page 39	
	Hydraulic power pack → Pages 148 – 149	
	Protective cover for weight, 9 kg → Page 143	
	Power supply unit for mounting frame → Page 155	

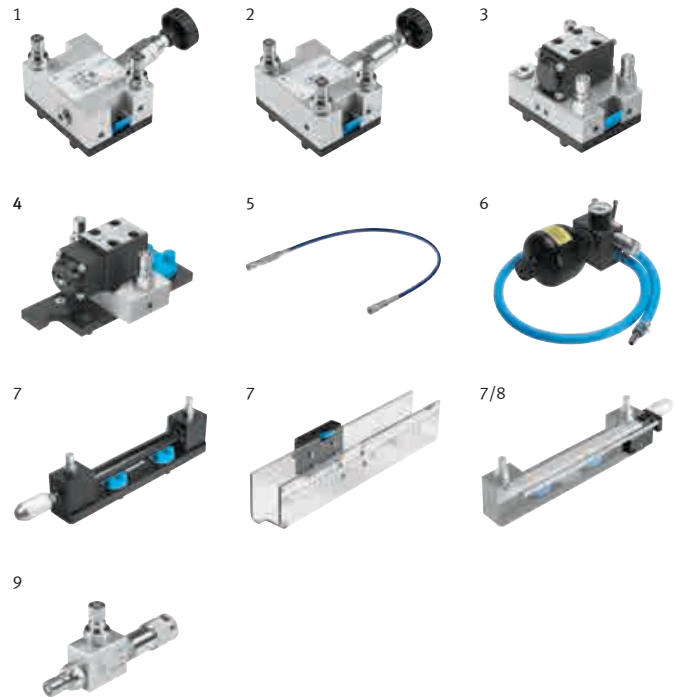

Also order:

Workbook

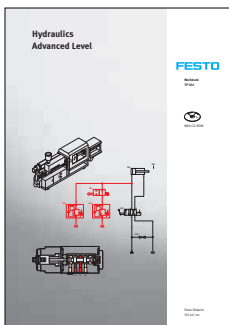

The tasks demonstrate advanced hydraulic circuits. The equipment set of package TP 501 – Hydraulics Basic Level and TP 502 – Advanced Level equipment set are needed to carry out the tasks.

The workbook contains:

- Sample solutions
- Training notes
- Multimedia CD-ROM with graphics, photos of industrial applications, animations, and FluidSIM® circuit diagrams
- Worksheets for students

Campus license (→ Page 19):

de	550142
en	551147
es	551148
fr	551149

Supplementary media

- Designing and simulating with FluidSIM®
- Measuring and controlling with FluidLab®
- WBT Hydraulics
- Textbook: Basic principles of Hydraulics and Electrohydraulics
- Hydraulics poster set

Hydraulics – Basic level – TP 501 America

Equipment set

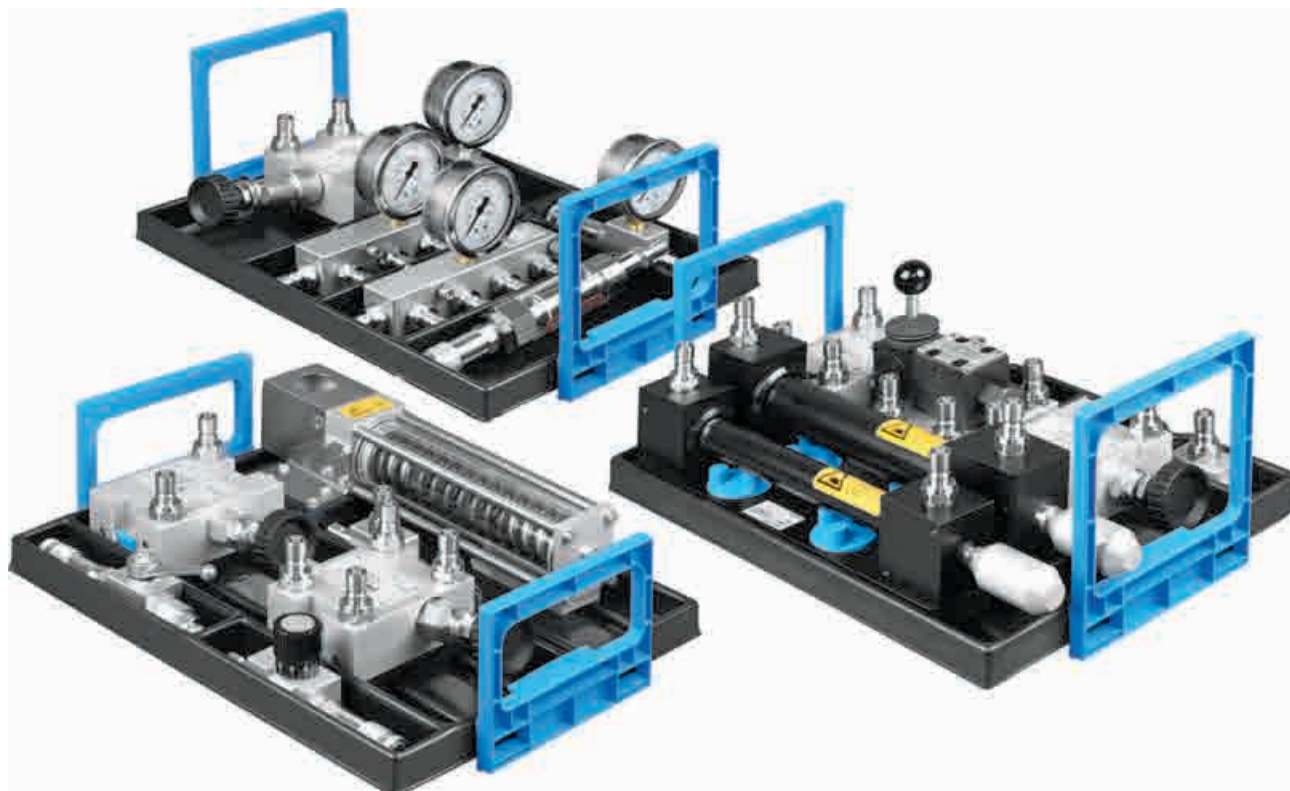

The Lab-Volt Hydraulics Fundamentals Successor

The Lab-Volt Fluid Power System has been re-engineered and transferred to Festo Didactic's Training Package series.

TP 501 America now combines the proven learning approach through object-oriented courseware from Lab-Volt with the project-orientation from Festo Didactic.

TP 501 America is the basic level for education in hydraulics and a prerequisite for TP 601 America, Electrohydraulics Basic Level.

TP 501 and TP 601 America support vocational training institutes in their mission to educate skilled, resourceful technicians and engineers, as required by the local industry.

Safe and sound system

The design of the system components ensures a high level of inherent safety.

The hydraulic hoses are equipped with leakage-free, self-sealing couplings in high-grade stainless steel that are easy on the environment and reduce contamination. The Spring load for cylinders comes with a safety cover to prevent potential hazards when high forces are involved.

The cylinders come with a safety cover, reducing the risk of injury, and include a guide for easy positioning and a tool-free quick-action mounting system.

All power pack motors are equipped with overload protection, protection against restart, and an easy-to-access emergency off button.

Pure convenience

- Easy and precise switching of hand-lever valves.
- Ergonomic handwheels with a high resolution allow the simple and precise setting of the flow and pressure valves.
- Tool-free, single-hand operation with Quick-Fix mounting system.
- The equipment trays fit exactly into the drawers in Learnline/Learntop workstations.
- The trays are compatible with the Systainer suitcases for enhanced mobility.
- The solid aluminum structure and profile bars can support heavy components without twisting or bending.
- Easy and precise positioning of components along the profile groove.

Training aims – TP 501 America

- Introduction to hydraulics
- Familiarization with the training system
- Basic principles of hydraulics
- Hydraulic power unit and distribution equipment

Valves

- Pressure relief valve
- Flow control valves
- Flow regulating valves
- Pressure-reducing valves
- Directional control valves

Basic controls of cylinders

- Cylinders – Direction and speed
- Cylinders – Pressure and force

Basic hydraulic circuits

- Meter-in/Meter-out configurations
- Securing a load
- Regenerative circuit
- Sequential circuit

Complete equipment set TP 501 America in equipment tray 8060227

The most important components at a glance:

1	1x Differential cylinder 16/10/200 with cover	572746
2	1x Differential cylinder 25/18/200 with cover	572747
3	1x 2-way flow control valve	544338
4	1x 4/3-way hand lever valve, closed mid-position, detenting	544343
5	1x Non-return valve, delockable	544339
6	1x Shut-off valve	152844
7	1x One-way flow control valve	152843
8	1x Pressure relief valve	544335
9	1x Pressure relief valve, piloted	8025067
10	1x Spring load for cylinders, hydraulic	4914138
11	1x Flow indicator with float	4857121
12	1x 3-way pressure reducing valve	544337
13	2x 4-way distributor with pressure gauge	159395
14	2x Pressure gauge	152841
15	4x T-distributor	152847

Necessary accessories, also order:

8x	Hose line with quick release couplings, 600 mm	152960
4x	Hose line with quick release couplings, 1000 mm	152970
4x	Hose line with quick release couplings, 1500 mm	159386
1x	Digital multimeter	8040005
Workstation → Page 39		
Hydraulic power pack → Pages 148 – 149		
1x	Power supply unit for mounting frame (NEMA 5-15 plug)	162411

Also order:

Courseware TP 501 America



Detailed procedure descriptions with hydraulic diagrams, thorough analysis, troubleshooting exercises, and comprehensive theory coverage provide the ideal preparation for the real-life industrial environment

Campus license (→ Page 19):

en **793157**

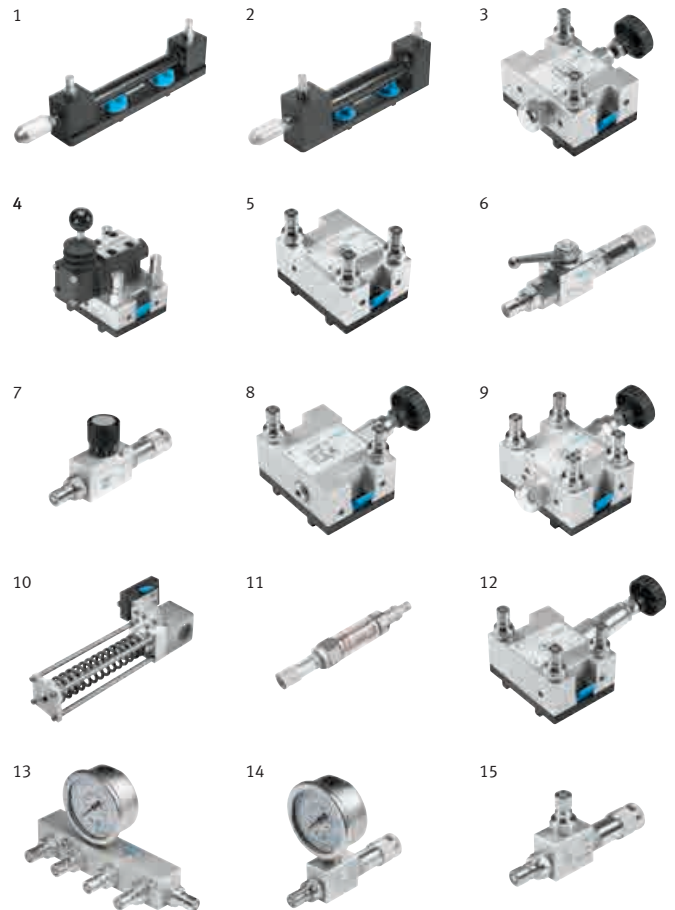

The Campus License consists of an Instructor Guide and a Student Manual.

In the courseware, exercises progressively increase in complexity, providing an ideal introduction to hydraulics.

Equipment set TP 601 – Basic Level

Basic training in electrohydraulics

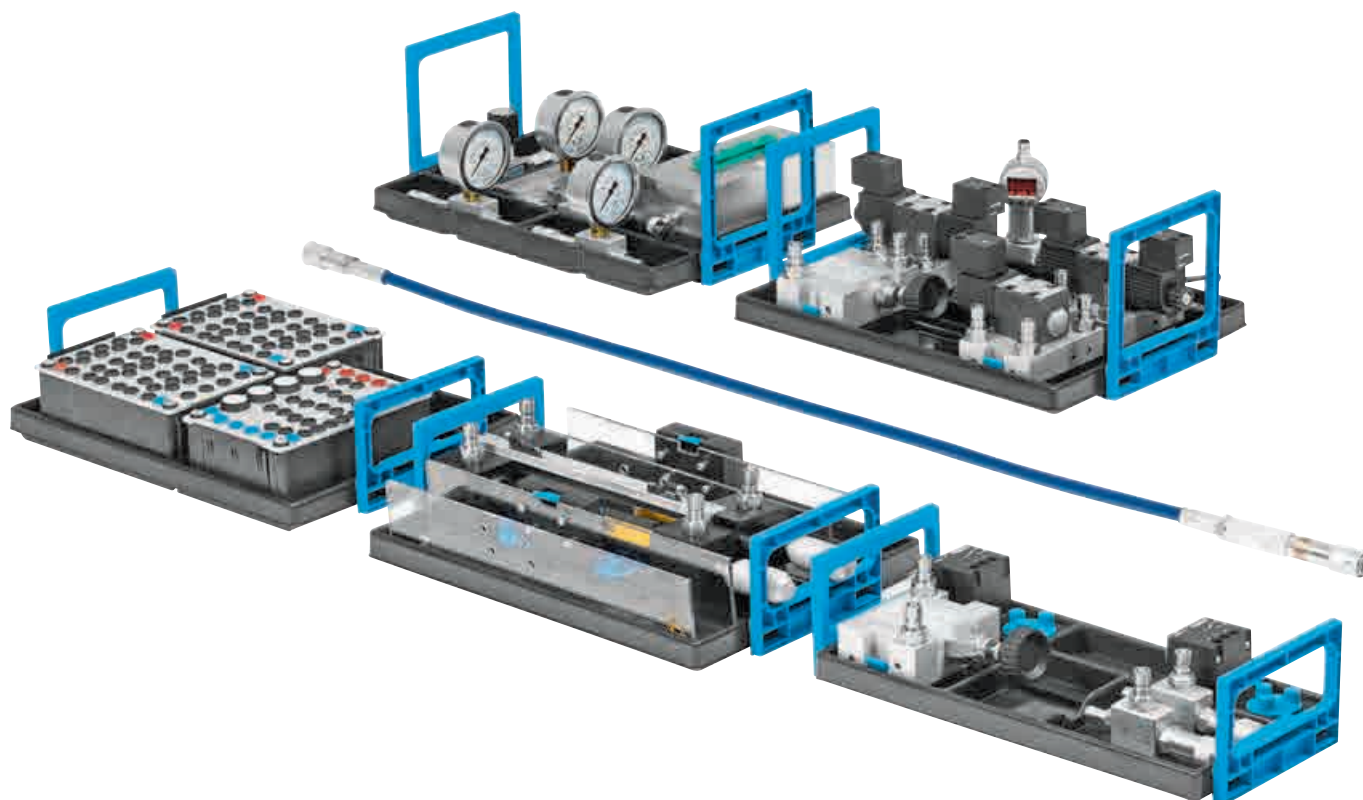

New edition of electrohydraulics!

TP 601 is a logical further development of electrohydraulics for training and specialized education. The equipment set contains only electro-hydraulic circuits and control systems.

The number and version of the components are specifically adapted to the projects in the workbook. This is a cost-effective way of teaching the important training objectives.

This equipment set provides students with knowledge about the basic physical principles of electrical engineering and electrohydraulics, as well as how electrohydraulic and control technology components function and are used.

Training content

Power packs and components:

- Design, mode of operation, and areas of application of 2/2, 3/2, 4/2, and 4/3-way solenoid valves, as well as 4/2-way double solenoid valves
- Design and mode of operation of electrical pushbuttons, switches, and limit switches
- Design and mode of operation of a relay
- Knowing and accounting for the contact load capacity of electrical signal transmitters
- Selecting and using hydraulic and electrical components according to economic criteria
- Design and mode of operation of a pressure switch
- Knowing different ways of sensing a cylinder's end position and selecting the right one

Hydraulic circuits:

- Commissioning hydraulic circuits safely
- Explaining and designing direct and indirect actuation
- Creating and using a sequence table
- Explaining and designing signal storage in the hydraulic power section
- Selecting solenoid valves according to the technical control requirements
- Using and designing basic logic functions
- Explaining and designing an electric latching circuit with a dominant switch-off signal
- Designing and arranging pressure-dependent control systems
- Knowing simple operating modes and accounting for them in the circuit
- Electrical and mechanical locking of signals in a relay control system

- Expanding existing control systems and adjusting the documentation accordingly
- Implementing sequence control with two cylinders
- Getting to know and creating a procedure description as GRAFCET and as a function diagram
- Analyzing circuits and carrying out systematic fault finding and error elimination with restart

Measurements and calculations:

- Measuring and calculating the flow in an electrohydraulic installation
- Calculating electrical characteristic values

Complete equipment set TP 601 in equipment tray 573037

The most important components at a glance:

1	1x Pressure relief valve	544335
2	1x 2-way flow control valve	544338
3	1x One-way flow control valve	152843
4	1x Non-return valve, 0.6 MPa opening pressure	548618
5	1x 4/2-way solenoid valve, spring return	544346
6	1x 4/3-way solenoid valve, closed mid-position	544347
7	1x 4/2-way double solenoid valve, detenting	544352
8	1x Shut-off valve	152844
9	1x Weight, 9 kg, for cylinder	152972
10	2x Differential cylinder 16/10/200 with cover	572746
11	1x Mounting kit for cylinders	544371
12	2x T-distributor	152847
13	2x 4-way distributor with pressure gauge	159395
14	2x Pressure gauge	152841
15	1x Pressure switch, electronic	548612
16	2x Relay, three-fold	162241
17	1x Signal input, electrical	162242
18	1x Limit switch, electrical, left-actuated	183322
19	1x Limit switch, electrical, right-actuated	183345
20	2x Proximity sensor, electronic	2342009

Necessary accessories, also order:

7x	Hose line with quick release couplings, 600 mm	152960
2x	Hose line with quick release couplings, 1000 mm	152970
4x	Hose line with quick release couplings, 1500 mm	159386
4 mm Safety laboratory cables → Page 155		
Digital multimeter		8040005
Aluminum profile plate → Page 39		
Hydraulic power pack → Pages 148 – 149		
Protective cover for weight, 9 kg → Page 143		
Tabletop power supply unit → www.festo-didactic.com		
Power supply unit for mounting frame → Page 155		

Also order:

Workbook



The basic electric circuits for hydraulic control technology are presented in 15 exercises. In order to carry out the exercises, students require the equipment set of TP 601 Electrohydraulics, Basic Level.

The workbook contains:

- Sample solutions
- Training notes
- Multimedia CD-ROM with graphics, photos of industrial applications, animations, and FluidSIM® circuit diagrams
- Worksheets for students

Campus license (→ Page 19):

de	550143
en	551150
es	551151
fr	551152

Supplementary media

- Designing and simulating with FluidSIM®
- Measuring and controlling with FluidLab®
- WBT Electrohydraulics
- Textbook: Basic principles of Hydraulics and Electrohydraulics
- Hydraulics poster set

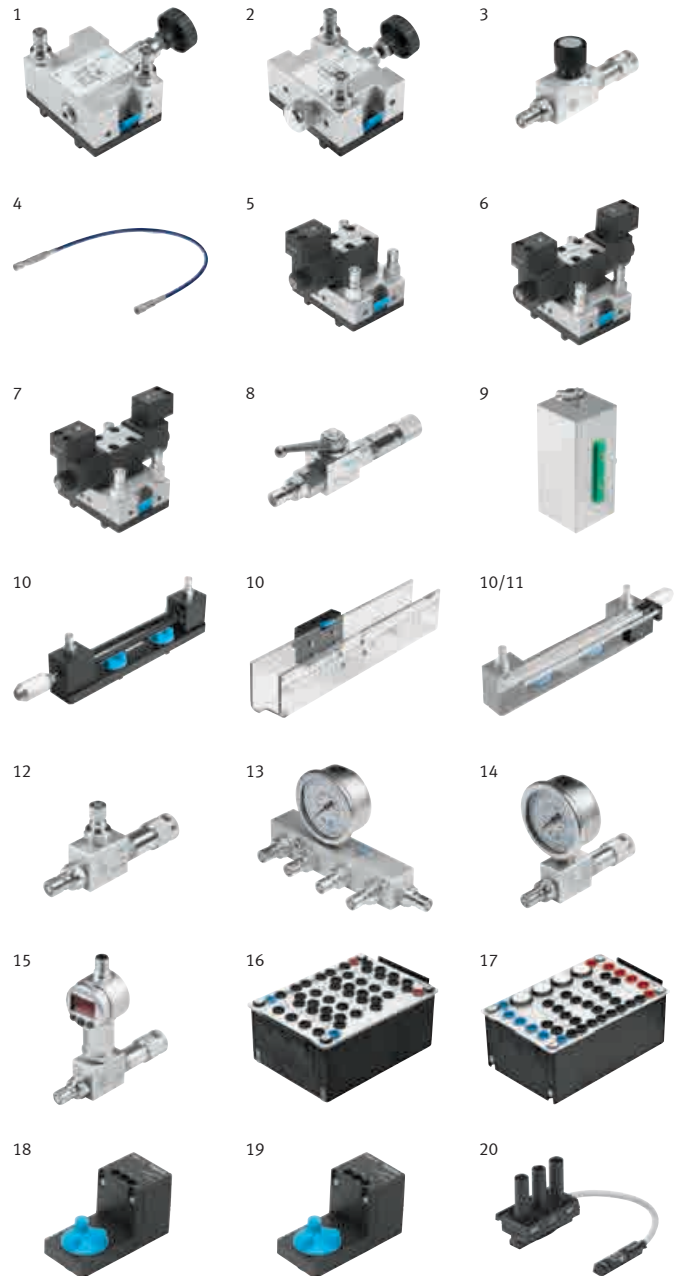

Supplementary equipment sets

Electrohydraulics

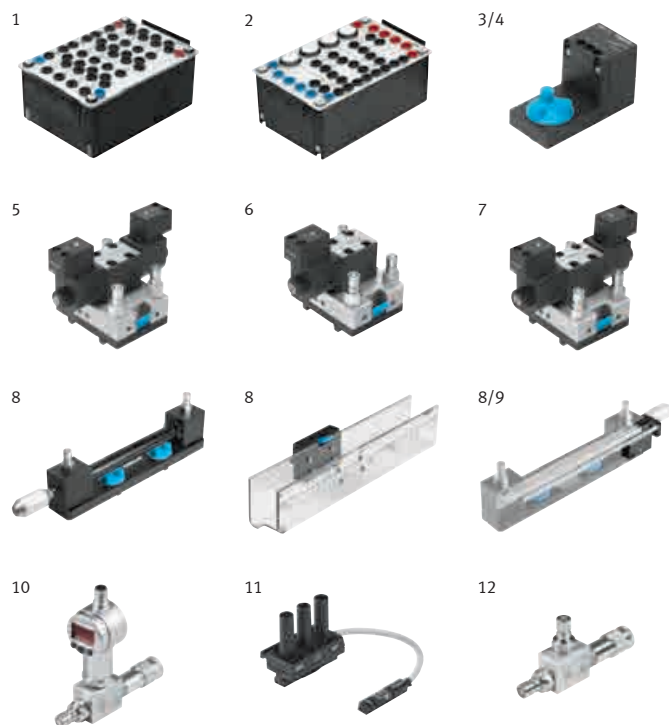

Supplementary equipment set from Hydraulics, Basic level TP 501 to Electrohydraulics, Basic level TP 601

For training aims, see Electrohydraulics, Basic level TP 601 equipment set.

Complete supplementary equipment set TP 501 – TP 601 **573039**

The most important components at a glance:

1	2x Relay, three-fold	162241
2	1x Signal input, electrical	162242
3	1x Limit switch, electrical, left-actuated	183322
4	1x Limit switch, electrical, right-actuated	183345
5	1x 4/2-way double solenoid valve, detenting	544352
6	1x 4/2-way solenoid valve, spring return	544346
7	1x 4/3-way solenoid valve, closed mid-position	544347
8	1x Differential cylinder 16/10/200 with cover	572746
9	1x Mounting kit for cylinders	544371
10	1x Pressure switch, electronic	548612
11	2x Proximity sensor, electronic	2342009
12	1x T-distributor	152847

Supplementary equipment set from Hydraulics, Basic level TP 501 and Advanced level TP 502 to Electrohydraulics, Basic level TP 601

For training aims, see Electrohydraulics, Basic level TP 601 equipment set.

Complete supplementary equipment set TP 501 and TP 502 – TP 601 **573040**

The most important components at a glance:

1	2x Relay, three-fold	162241
2	1x Signal input, electrical	162242
3	1x Limit switch, electrical, left-actuated	183322
4	1x Limit switch, electrical, right-actuated	183345
5	1x 4/2-way double solenoid valve, detenting	544352
6	1x 4/2-way solenoid valve, spring return	544346
7	1x 4/3-way solenoid valve, closed mid-position	544347
10	1x Pressure switch, electronic	548612
11	2x Proximity sensor, electronic	2342009

Supplementary equipment sets

Controllers for electrohydraulics

Supplementary equipment set Controlling using FluidSIM®/ EasyPort USB

With this package, the FluidSIM® software can be used to control training packages. FluidSIM® controls via EasyPort USB and processes the inputs and outputs connected to the universal connection unit according to their programming, e.g., using the digital module contained in FluidSIM®.

The Controlling using FluidSIM® package contains everything you need to control training packages TP 201 and TP 601. FluidSIM® Pneumatics is required for TP 201 and FluidSIM® Hydraulics for TP 601. A set of brief instructions provides information on the individual steps.

The sample solutions are included on a data storage medium as FluidSIM® CT programs.



Complete supplementary equipment set Controlling using FluidSIM/EasyPort USB in equipment tray		556270
--	--	---------------

The most important components at a glance:

1	1x Brief instructions for FluidSIM, de/en/es/fr	556267
2	1x EasyPort USB	548687
3	1x Quick-Fix screw adapter	549806
4	1x Universal connection unit, digital (SysLink)	162231
5	1x I/O data cable with SysLink connectors (IEEE 488) at both ends, 2.5 m	34031

Prerequisite:

Equipment set TP 601 – Basic Level → Pages 92 – 93
FluidSIM Hydraulics → Pages 12 – 13
Aluminum profile plate → Page 39

Supplementary equipment set Controlling using LOGO! 8 TP EduTrainer® Compact TP/LOGO! Soft Comfort

A quick, straightforward, and inexpensive introduction to logical signal processing.

With its extensive basic and special control technology functions, LOGO! replaces a variety of conventional switchgears and control devices.

The LOGO! 8 TP EduTrainer® Compact training package contains everything you need to control training packages TP 201 and TP 601. A set of brief instructions provides information on the individual steps. Programming is carried out using the LOGO! programming software, Soft Comfort.

The sample solutions are included on a data storage medium as LOGO! Soft Comfort programs.

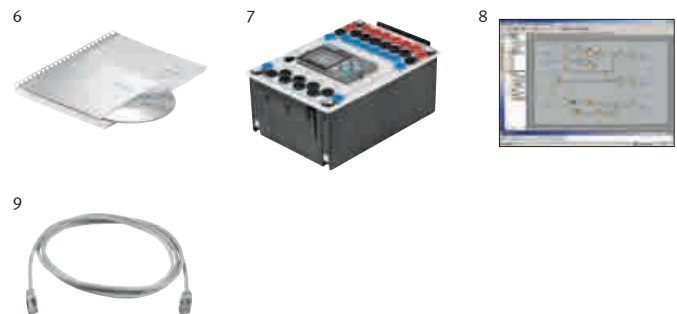

Complete supplementary equipment set with LOGO! 8 TP EduTrainer Compact TP/LOGO! Soft Comfort included in order		8049517
---	--	----------------

The most important components at a glance :

6	1x Brief instructions for LOGO!, de/en/es/fr	8049519
7	1x LOGO! 8 TP EduTrainer Compact TP	8040886
8	1x LOGO! Soft Comfort, de/en/es/fr	8040050
9	1x Ethernet cable	567280

Prerequisite:

Equipment set TP 601 – Basic Level → Pages 92 – 93
--

Necessary accessories, also order:

Hydraulic power pack → Pages 148 – 149
Power supply unit for mounting frame → Page 155
4 mm Safety laboratory cables → Page 155

For additional controllers suitable for your requirements see:
→ www.festo-didactic.com
Keyword “EduTrainer Compact”

Equipment set TP 602 – Advanced Level

Electrohydraulics for advanced students

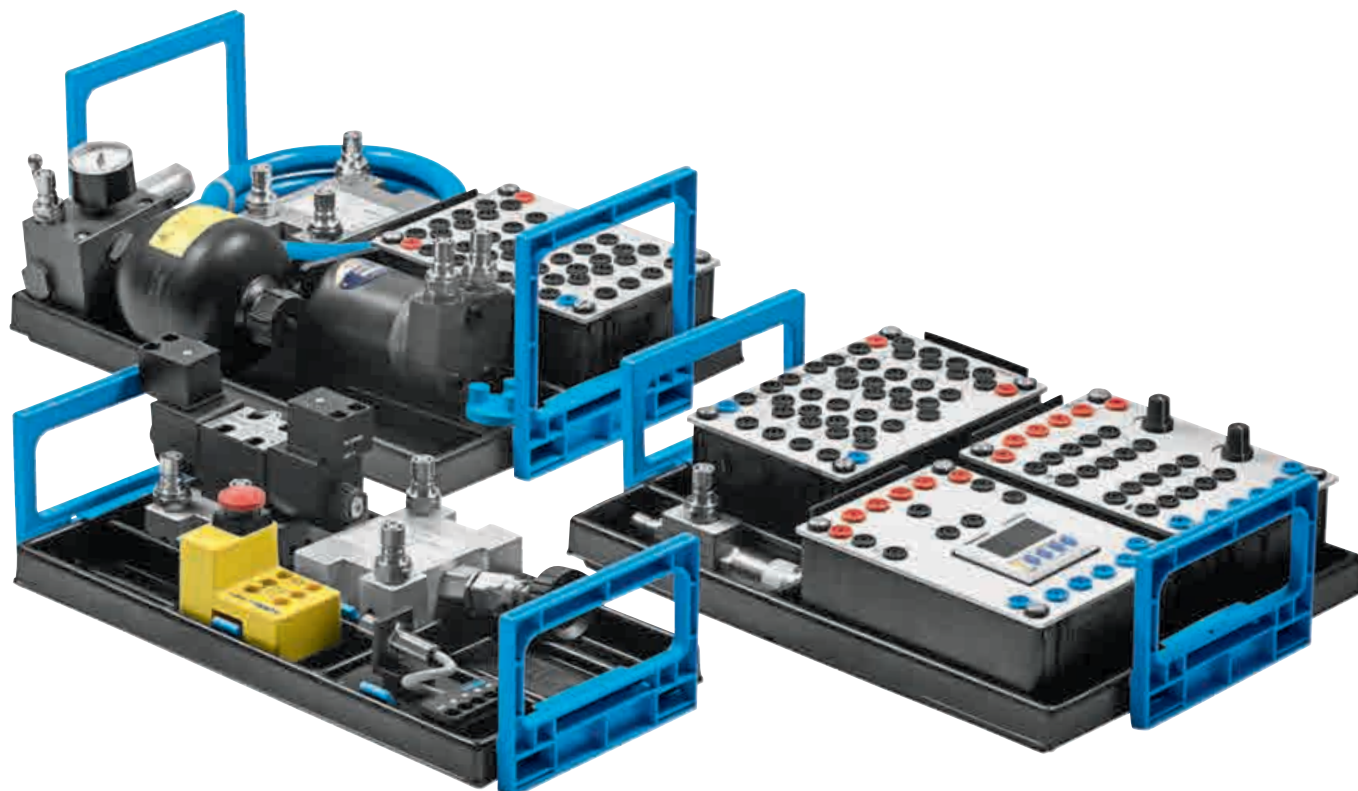

The new advanced level

The training package TP 602 builds directly on the material covered in basic principles package TP 601 adding more in-depth projects.

It provides students with advanced knowledge about the basic physical principles of electrical engineering and electrohydraulics, as well as how electrohydraulic and control technology components function and are used.

In order to carry out the projects, users require the components and the necessary accessories from TP 601.

The number and version of the components are specifically adapted to the projects in the workbook. This makes it possible to achieve many important training objectives at little cost.

Training content

Power packs and components:

- Design and mode of operation of different proximity sensors
- Function and possible applications of a time relay with switch-on and switch-off delay
- Design and use of an electrical predetermining counter

Learning objectives for hydraulic circuits:

- Selecting proximity sensors according to the technical control requirements
- Expanding electrohydraulic control systems and adjusting the documentation
- Designing and arranging path- and pressure-dependent sequence controls
- Identifying signal overlaps in a sequence control and taking the appropriate action
- Designing and arranging sequence control as a standing sequencer

- Using memory to implement an emergency operation
- Implementing control systems with the operating modes single cycle and continuous cycle
- Querying time in electrohydraulic control systems
- Getting to know and using further logical connections
- Designing and arranging pressure sequence control
- Knowing safety-related conditions that could be needed for a drive
- Designing and arranging safety functions with a predefined motion sequence for a control system
- Implementing control systems with the operating modes inching and aligning
- Systematically identifying and eliminating errors in complex electrohydraulic control systems
- Creating sequence control as a displacement-step diagram
- Representing procedure descriptions with GRAFCET

Hydraulics plus!

Delivered in practical, Systainer-compatible equipment trays. The trays fit into the drawers in Learnline workstations. The new components, with added training value and relevant project tasks, form the basis for advanced training in fundamental principles.

Complete equipment set TP 602 in equipment tray 573038

The most important components at a glance:

1	1x Time relay, two-fold	162243
2	2x Relay, three-fold	162241
3	1x Preset counter, electronic	1677856
4	1x Diaphragm accumulator with shut-off block	152859
5	1x Hydraulic motor	152858
6	1x 4/3-way solenoid valve, relieving mid-position (AB -> T)	544348
7	1x Proximity sensor, inductive, M12	548643
8	1x Emergency stop pushbutton, electrical	183347
9	1x T-distributor	152847
10	1x Non-return valve, delockable	544339
11	1x Pressure relief valve, compensated	567237

Necessary accessories, also order:

8x	Hose line with quick release couplings, 600 mm	152960
4x	Hose line with quick release couplings, 1000 mm	152970
2x	Hose line with quick release couplings, 1500 mm	159386
	4 mm Safety laboratory cables → Page 155	
	Digital multimeter	8040005
	Aluminum profile plate → Page 39	
	Hydraulic power pack → Pages 148 – 149	
	Protective cover for weight, 9 kg → Page 143	
	Tabletop power supply unit → www.festo-didactic.com	
	Power supply unit for mounting frame → Page 155	

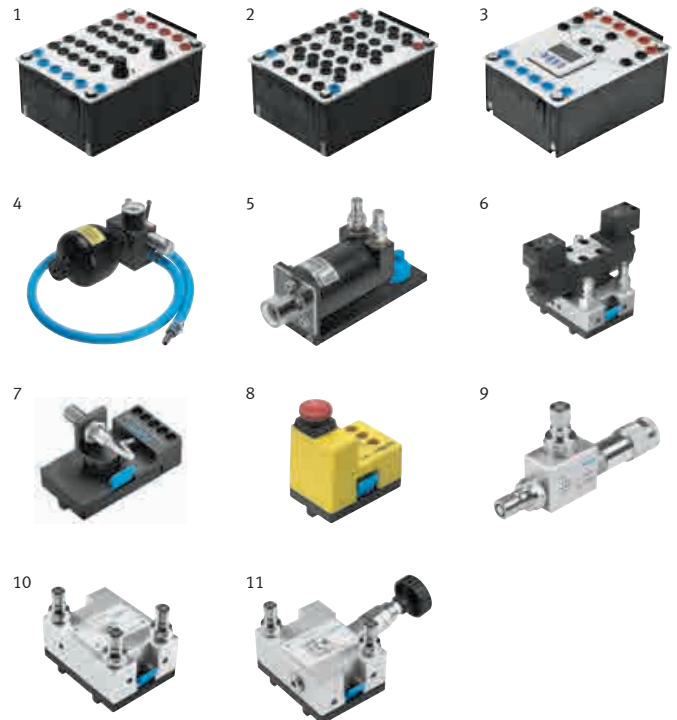

Also order:

Workbook



The basic practical circuits in electrohydraulics are presented in 12 exercises. In order to carry out the exercises, students require the equipment set of TP 601 Electrohydraulics, Basic Level and Advanced Level TP 602.

The workbook contains:

- Sample solutions
- Training notes
- Multimedia CD-ROM with graphics, photos of industrial applications, animations, and FluidSIM® circuit diagrams
- Worksheets for students

Campus license (→ Page 19):

de	550144
en	551153
es	551154
fr	551155

Supplementary media

- Designing and simulating with FluidSIM®
- Measuring and controlling with FluidLab®
- WBT Hydraulics
- WBT Electrohydraulics
- Textbook: Basic principles of Hydraulics and Electrohydraulics
- Hydraulics poster set

Electrohydraulics – Basic level – TP 601 America

Supplementary equipment set TP 501 A – TP 601 A

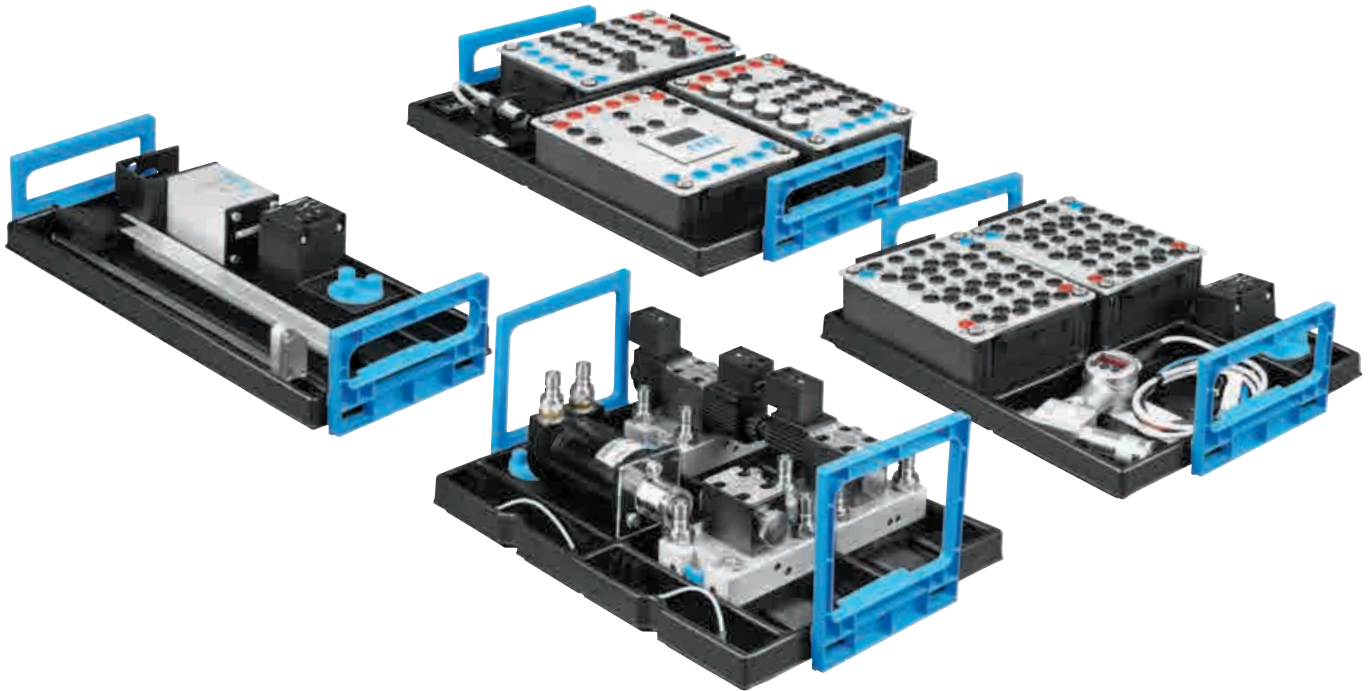

The Lab-Volt Hydraulics Electrical Control successor

The Lab-Volt Fluid Power System has been re-engineered and transferred to Festo Didactic's Training Packages series.

TP 601 America is an extension to TP 501 America and a comprehensive introduction to electrohydraulics.

Equipment set TP 501 America is a prerequisite to use TP 601 America.

The electrical symbols in the courseware and on the modules are drawn according to NEMA standards. The design and simulation software FluidSIM® provides all required NEMA symbols in easy-to-access component libraries. In addition, all circuits in the courseware procedures are available in FluidSIM® for reference.

Next step: our additions – your choice

A variety of possibilities can be added according to your educational needs.

Supplementary equipment sets:
 TP 610 – Measurement and control
 TP 810 – Diagnostic system for measurement, visualization, and analysis

Mobile Hydraulics training packages addressing the needs of future professionals dealing with vehicles e. g. from the construction, mining, and agriculture industries:
 TP 801 – Mobile Hydraulics/Working Hydraulics I
 TP 802 – Hydrostatic steering system
 TP 803 – Working Hydraulics II (Load-Sensing)

Hydraulics energy supply

A variety of hydraulic power packs are available.

For basic hydraulic education workstations, a small hydraulic power pack with a single, constant-displacement pump is recommended. For double-sided workstation arrangements, two power packs are required to power each workplace individually.

For double-sided workstations covering basic and advanced hydraulics, a hydraulic power pack with two constant-displacement pumps and a higher flow rate is recommended. The power pack can be fitted with a wheel set to make it mobile beside the workstation.

The hydraulic power pack combining a load sensing controller and a variable and constant displacement pump is required only for TP 803 – Working Hydraulics II (Load-Sensing) but can be used also for the basics by using the constant pump.

Training aims – TP 601 America

Introduction to electrohydraulics
 – Familiarization with the equipment
 – Electrical concepts
 – Basic electricity
 – Ladder diagrams and logic operators
 – Basic electrohydraulic circuits

Sequence systems
 – Limit switches
 – Pressure switches
 – Electrical counters and continuous reciprocation
 – Multi-pressure systems
 – Time-delay relays

Hydraulic motors and industrial applications
 – Hydraulic motors
 – Optical proximity sensors
 – Flow divider valves
 – Deceleration of cylinders
 – Industrial drilling systems
 – Garbage compactor circuit

Troubleshooting
 – Troubleshooting electrical control circuits
 – Troubleshooting electrohydraulic systems

Complete supplementary equipment set TP 501 A – TP 601 A in equipment tray 8060228

The most important components at a glance:

1	1x Flow dividing valve	544340
2	1x 4/2-way solenoid valve, spring return	544346
3	1x 4/3-way solenoid valve, bypass mid-position (P → T)	544349
4	1x Mounting kit for cylinders	544373
5	1x Hydraulic motor	152858
6	1x Pressure switch, electronic	548612
7	1x Flow sensor	567191
8	1x Signal input, electrical	8062950
9	1x Time relay, two-fold	8062960
10	1x Proximity sensor, optical, M12	8062967
11	1x Limit switch, electrical, left-actuated	183322
12	1x Limit switch, electrical, right-actuated	183345
13	1x Preset counter, electronic	8062962
14	2x Relay, three-fold	8062958
15	2x Proximity sensor, electronic	2342009

Necessary accessories, also order:

8x	Hose line with quick release couplings, 600 mm	152960
4x	Hose line with quick release couplings, 1000 mm	152970
4x	Hose line with quick release couplings, 1500 mm	159386
1x	4 mm Safety laboratory cables, 106 pieces, red, blue, and black	571806
1x	Digital multimeter	8040005
Workstation → Pages 39		
Hydraulic power pack → Pages 148 – 149		
1x	Power supply unit for mounting frame (NEMA 5-15 plug)	162411
Only required when upgrading to TP 610		
1x	4/3-way solenoid valve, closed mid-position	544347

Also order:

Courseware TP 601 America



Detailed procedure descriptions with hydraulic and electrical diagrams, thorough analysis, troubleshooting exercises, and comprehensive theory coverage provide the ideal preparation for the real-life industrial environment.

Campus license (→ Page 19):

en **793158**

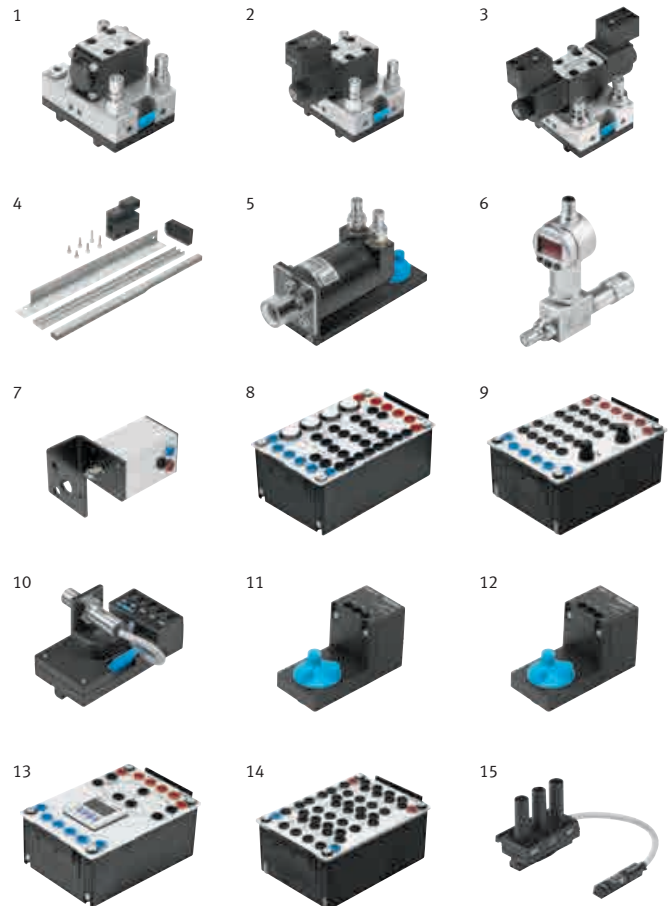

The Campus License consists of an Instructor Guide and a Student Manual.

In the courseware, exercises progressively increase in complexity, providing an ideal introduction to electrohydraulics.

Equipment set TP 610 – Advanced level

Measurement and control in Hydraulics with FluidLab®-H

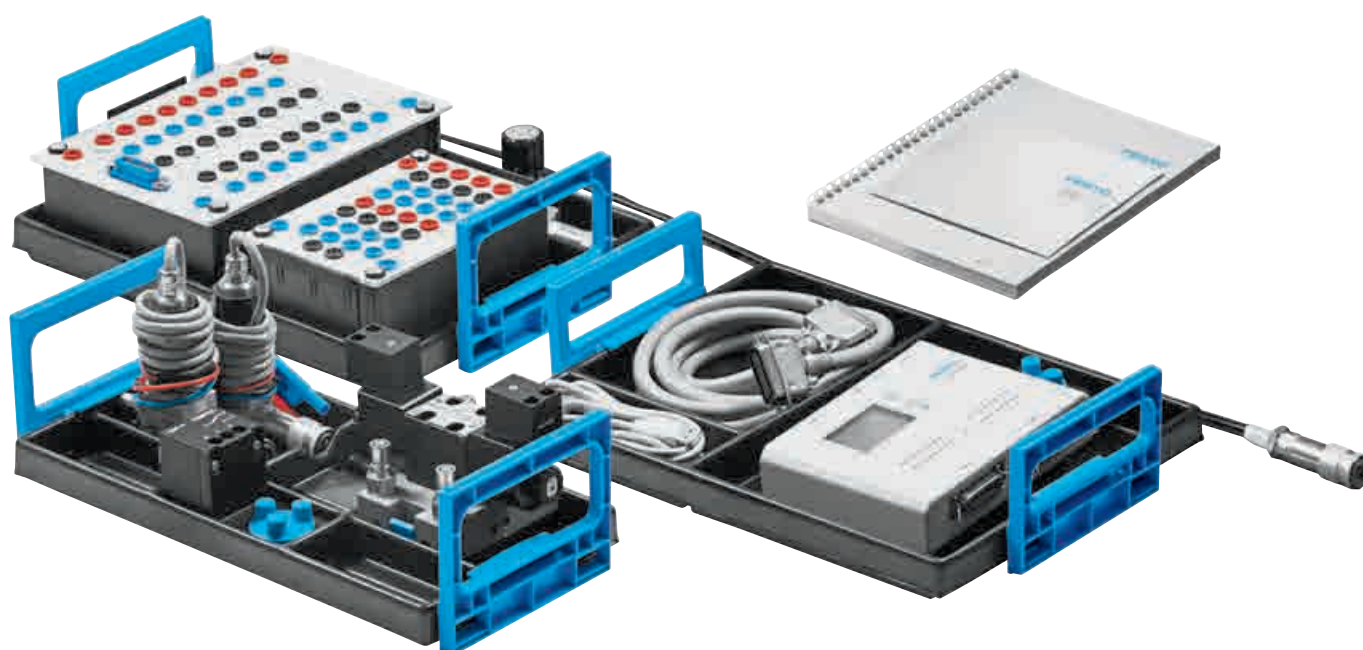

Fit for tomorrow?

The equipment set for TP 610 expands the training content of TP 501 and TP 601 to include the topic of hydraulics measurement and control. The material covered ranges from recording simple characteristic curves of individual hydraulic valves through to the basic principles of cylinder control. In addition, awareness is raised in a clear and striking manner about the effective use of hydraulic energy, e.g. with resistance experiments.

New features of FluidLab®-H include the measurement experiments for proportional technology with recording characteristic curves, and applications such as pressure stages and rapid traverse feed circuits, as well as control technology with position, sequence and pressure control.

Exercises for the measurement and analysis of system and control behavior point to a future in which diagnostics, preventative maintenance, and saving energy are becoming more and more important.

Something extra special

In order to complete the exercises, sensors (e.g., pressure, flow and position) are connected to the inputs, and control signals are transmitted to the EasyPort USB outputs. The FluidLab®-H software included in the scope of delivery interprets and visualizes the signals. Analog values are displayed as measurement curves.

Each exercise includes notes on its implementation, with positional sketches and block circuit diagrams. Students are guided step-by-step through the experiments. Measured results are then interpreted and compared with sample solutions, and questions are asked to check students' understanding.

Training content

- Basic principles of analog processing
- Using and adjusting sensors
- Interpreting measurement results
- Reading and understanding technical data and measurement curves
- Getting to know fluid engineering components and their influence and function
- Demonstrating fluid engineering effects and special features
- Analytical fault finding
- Hydraulic energy
- Evaluating changes of state
- Proportional technology
- Control technology with position, sequence and pressure control

Your advantages

- Fast, PC-supported recording of measured values
- Greater training success through measurement of components and interpretation of results
- Sensors that enable students “to look into” the circuit and components
- Suppositions regarding system behavior can be easily proven
- Learning the principles of measurement and analysis and applying them directly in other circuits
- Demonstrate and understand the principles of fluid engineering faster
- System analysis via a PC: State-of-the-art diagnostic method
- Better understanding of fluid engineering components and processes and thus better training outcomes

Complete equipment set TP 610 in equipment tray 567194

The most important components at a glance:

1	1x I/O data cable with SysLink connectors (IEEE 488) at both ends, 2.5 m	34031
2	1x Universal connection unit, digital (SysLink)	162231
3	1x Analog cable, parallel, 2 m	529141
4	1x Connection unit, analog	567232
5	1x EasyPort USB	548687
6	1x Quick-Fix screw adapter	549806
7	1x 4/3-way solenoid valve, relieving mid-position (AB → T)	544348
8	2x Pressure sensor	525964
9	1x Flow control valve	152842
10	1x Resistance hose line with quick release couplings, 1000 mm	549858
11	1x FluidLab-H Single license, de/en	573286
12	1x Limit switch, electrical, left-actuated	183322

The exercises for proportional and control hydraulics also require:

Proportional amplifier	162255
Displacement encoder for cylinder, 200 mm stroke	167090
Mounting kit for cylinders	544371
4/3-way proportional valve	544350
Proportional pressure relief valve	544351
Pressure filter	548609

Optionally, the regulating valve can be used instead of the proportional amplifier with the proportional valves for the control technology exercises.

4/3-way regulating valve	567269
--------------------------	--------

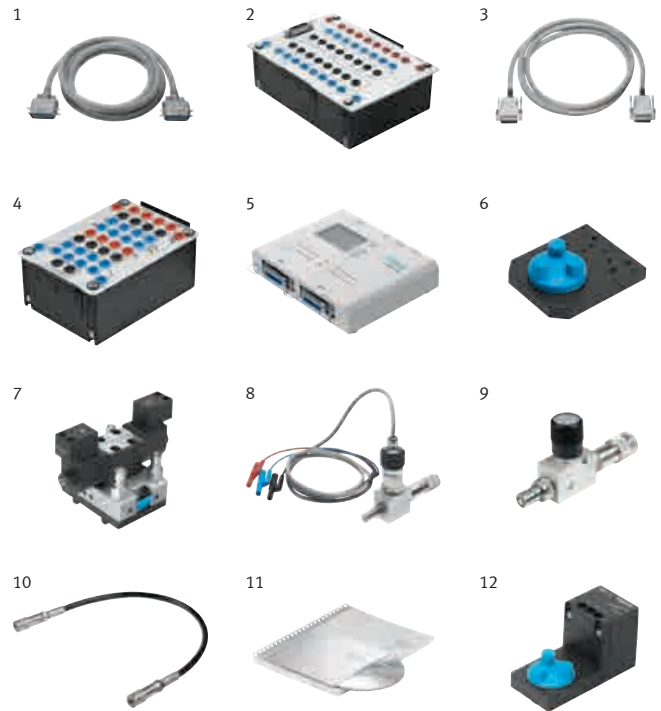

Includes FluidLab®-H measurement software

The FluidLab®-H software is an important component of the training package TP 610. Just a few simple steps are needed to configure the interface, adapt the sensors, and select the language (de/en). Then the exercises can begin, which are divided into the areas of basic experiments, cylinder controls, proportional technology and control engineering. Connection diagrams, descriptions, and sample solutions support students during the exercises. The software also controls the measurement sequence. Diagrams can be dimensioned and printed out using the cursors. The software also includes the complete book of exercises, with sample solutions, in PDF format.

System requirements

- PC with Windows 7/8/10
- Pentium® III or equivalently
- 2 GB RAM
- CD-ROM disk drive
- USB 2.0 or serial interface
- 1280 x 1024 pixels
- NI LabView 2012 Runtime (included in scope of delivery)

To carry out the exercises, students require the components and appropriate accessories from training packages 501 and 601.

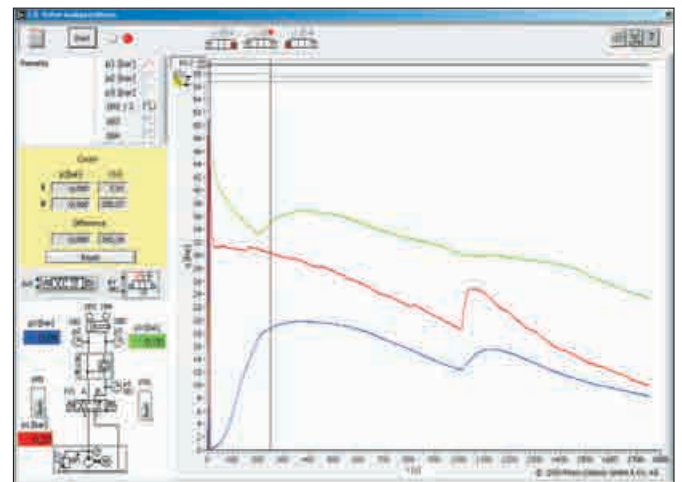

Equipment set TP 701 – Basic level

Basic proportional hydraulics training



Proportional hydraulics, Basic Level

Proportional valves are continuous valves that, thanks to proportional magnets, not only permit simple switching positions, but also enable a continuous transition in the valve opening.

These valves are specifically used in hydraulics where variable volumetric flows (proportional directional control valve or proportional throttle) are needed together with load compensation (proportional flow control valve) or variable pressures (proportional pressure-relief valve). The equipment set provides information about proportional valves, how they function, and how they are activated using proportional amplifiers and a setpoint value card. The set can be used to design, set, and commission simple proportional control systems.

Training content

Components:

- Design and function of different proportional valves
- Characteristic curves and characteristics of proportional valves
- Design and function of amplifiers and setpoint specification
- Getting to know the characteristics of the 1 and 2-channel amplifier
- Completely setting the 1-channel amplifier
- Setting the basic current, step current, and maximum current
- Getting to know the characteristics of the 4/3-way proportional valve and the proportional pressure-relief valve
- Deriving the settings for the 2 channel amplifier
- Setting ramps
- Deriving the ramp settings from the function diagram

Measurements and calculations:

- Determining characteristic curves and characteristics of valves and equipment
- Measuring parameters such as pressure, volumetric flow, and time
- Calculating the flow for proportional directional control valves
- Calculating speeds for double-acting cylinders with varying load
- Calculating the natural frequency of a cylinder drive
- Calculating times for acceleration and braking

Hydraulic circuits:

- Controlling pressure and speed
- Reading and creating hydraulic and electric circuit diagrams
- Creating a function diagram
- Designing and commissioning control systems, including fault finding
- Basic circuits for proportional hydraulics, such as pressure stage circuit, rapid traverse feed circuit, pump bypass, approaching positions, controlled acceleration and braking, logically connecting setpoint values, load-independent speeds
- Getting to know the pressure stage control system
- Braking a cylinder feed
- Reversing a hydraulic motor
- Setting process-dependent pressure stages
- Externally and logically interconnecting setpoint values
- Approaching a position with braking
- Creating a load-independent feed speed

Complete equipment set TP 701 184465

The most important components at a glance:

1	1x Relay, three-fold	162241
2	1x Proportional amplifier	162255
3	1x Setpoint value card	162256
4	1x Signal input, electrical	162242
5	2x Proximity sensor, inductive, M12	548643
6	1x 4/3-way proportional valve	544350
7	1x 4/2-way solenoid valve, spring return	544346
8	1x Proportional pressure relief valve	544351
9	1x Pressure filter	548609
10	1x Pressure balance (proportional flow control valve)	159351
11	1x Pressure relief valve	544335
12	1x Differential cylinder 16/10/200 with cover	572746
13	1x Hydraulic motor	152858
14	1x Flow control valve	152842
15	1x One-way flow control valve	152843
16	2x Pressure gauge	152841
17	2x T-distributor	152847
18	1x Weight, 9 kg, for cylinder	152972

Necessary accessories, also order:

5x	Hose line with quick release couplings, 600 mm	152960
2x	Hose line with quick release couplings, 1500 mm	159386
	Measuring case	177468
	Pressure relief unit	152971
	4 mm Safety laboratory cables → Page 155	
	Aluminum profile plate → Page 39	
	Hydraulic power pack → Pages 148 – 149	
	Protective cover for weight, 9 kg → Page 143	
	Tabletop power supply unit → www.festo-didactic.com	
	Power supply unit for mounting frame → Page 155	

Also order:

Workbook



Ten exercises provide an introduction to the equipment and circuits for proportional hydraulics. Individual items of equipment are presented and their settings are tested. The progressively complex exercises then provide a complete solution.

The workbook contains:

- Sample solutions
- Training notes
- Multimedia CD-ROM with graphics, photos of industrial applications, animations, and FluidSIM® circuit diagrams
- Worksheets for students

Campus license (→ Page 19):

de	94457
en	94472
es	94404
fr	94352

Supplementary media

- Designing and simulating with FluidSIM®
- Measuring and controlling with FluidLab®
- WBT Hydraulics
- WBT Electrohydraulics
- WBT Open- and closed-loop control
- Textbook: Proportional hydraulics, Basic level
- Hydraulics poster set

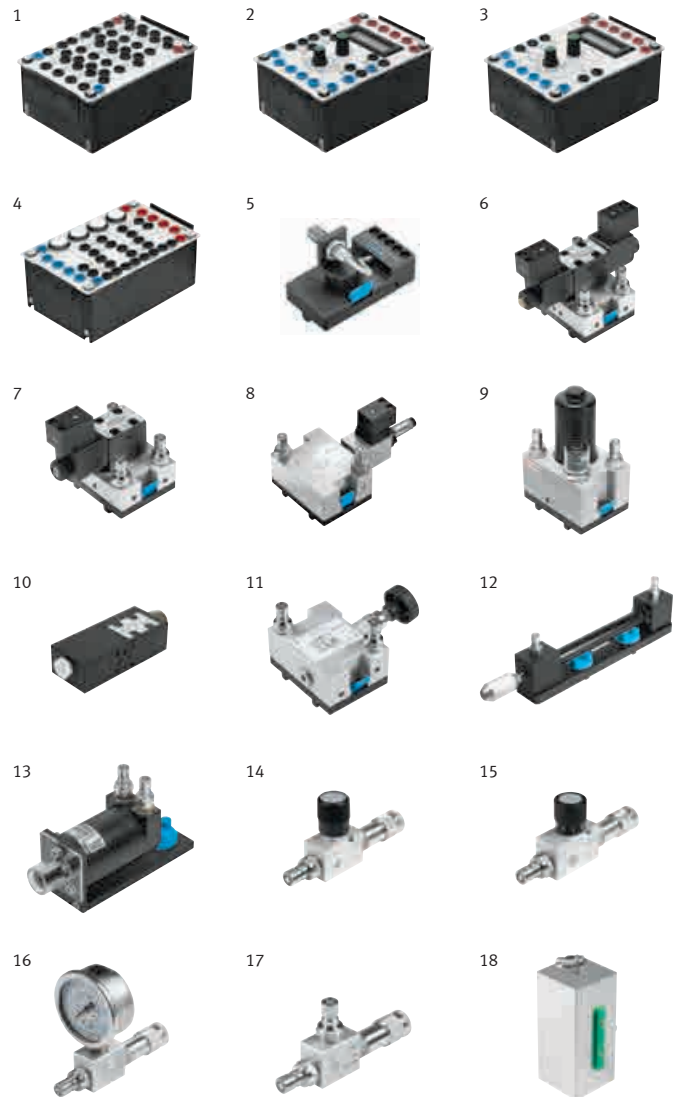

Equipment set TP 702 – Advanced level

Advanced proportional hydraulics training

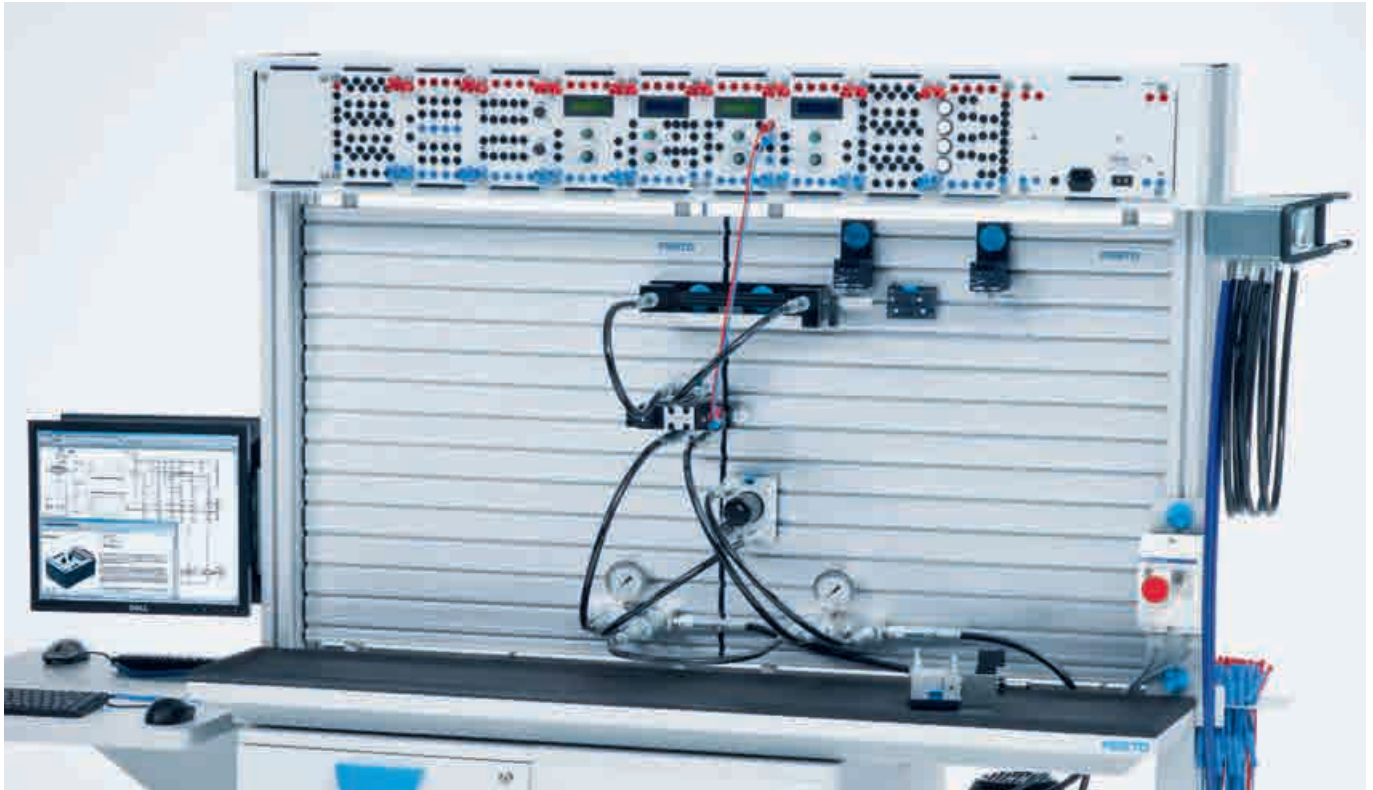

Proportional hydraulics, Advanced Level

The training package TP 702 builds directly on the material covered in package TP 701, Basic Level, and adds nine additional more in-depth and real-life case studies.

The package includes the following steps:

- Understanding the task using a positional sketch, diagram and problem description
- Designing the hydraulic circuit diagram
- Determining the necessary signal transmitters
- Compiling the sequence table
- Designing the electric signal control system
- Structuring and commissioning the proportional hydraulic control system
- Settings and evaluating the result

Training content

Components:

- Determining characteristic curves and characteristics of different sensors
- Coordinating electrical and hydraulic equipment
- Creating characteristic curves for displacement, pressure, and temperature sensors

Measurements and calculations:

- Measuring and processing parameters such as displacement, time, pressure, and temperature
- Further signal processing of analog signals

Hydraulic circuits:

- Controlling pressure, speed, acceleration, delay, and position
- Reading and creating proportional hydraulic and electric circuit diagrams
- Reading motion diagrams
- Designing and commissioning proportional hydraulic control systems, including fault finding
- Adjusting and coordinating as per the specified procedure description
- Using basic circuits for proportional hydraulics such as: speed, rotational speed, stage, acceleration, braking, and differential circuits, as well as positioning
- Implementing specific displacement-time and positioning programs
- Setting precise switch-off positions
- Implementing drive acceleration with a proportional pressure-relief valve
- Implementing oscillating movements for a cylinder with a proportional hydraulic control system
- Implementing the specified speed profile by means of an additional bypass circuit and slow retraction to the end positions
- Implementing a travel process with a 2/2-way proportional valve and a proportional pressure-relief valve

Complete equipment set TP 702 184466

The most important components at a glance:

1	1x Setpoint value card	162256
2	1x Comparator	162257
3	1x Time relay, two-fold	162243
4	1x Indicator unit and distributor, electrical	162244
5	3x Relay, three-fold	162241
6	1x Limit switch, electrical, left-actuated	183322
7	1x Limit switch, electrical, right-actuated	183345
8	1x Proximity sensor, capacitive, M12	548651
9	1x Proximity sensor, optical, M12	572744
10	1x Non-return valve, delockable	544339
11	1x T-distributor	152847
12	1x Non-return valve, 0.05 MPa opening pressure	548617
13	1x Displacement encoder for cylinder, 200 mm stroke	167090
14	1x Mounting kit for cylinders	544371

Necessary accessories, also order:

5x	Hose line with quick release couplings, 600 mm	152960
3x	Hose line with quick release couplings, 1000 mm	152970
2x	Hose line with quick release couplings, 1500 mm	159386
	Measuring case	177468
	Pressure relief unit	152971
	4 mm Safety laboratory cables → Page 155	
	Aluminum profile plate → Page 39	
	Hydraulic power pack → Pages 148 – 149	
	Protective cover for weight, 9 kg → Page 143	
	Power supply unit for mounting frame → Page 155	

Also order:

Workbook



Nine exercises illustrate the most important circuits and equipment in proportional hydraulics. To carry out the exercises, the equipment sets for proportional hydraulics TP 701 (Basic Level) and TP 702 (Advanced Level) are required.

The workbook contains:

- Sample solutions
- Training notes
- Worksheets for students

Campus license (→ Page 19):

de	94458
en	94473
es	94450

Supplementary media

- Designing and simulating with FluidSIM®
- Measuring and controlling with FluidLab®
- WBT Hydraulics
- WBT Electrohydraulics
- WBT Open- and closed-loop control
- Textbook: Proportional hydraulics, Basic level
- Hydraulics poster set

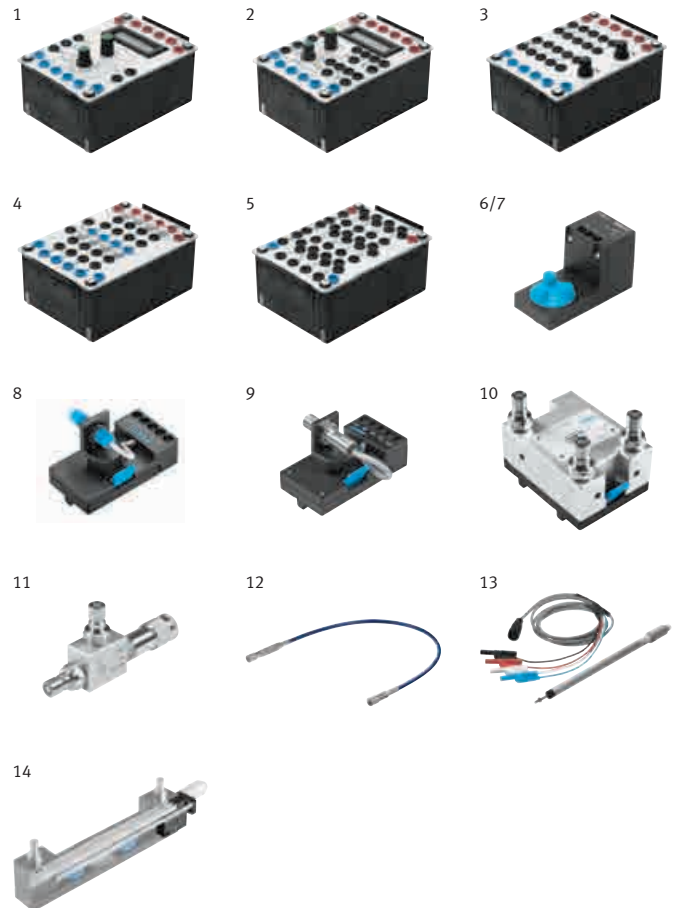

Equipment set TP 511

Basic closed-loop hydraulics training

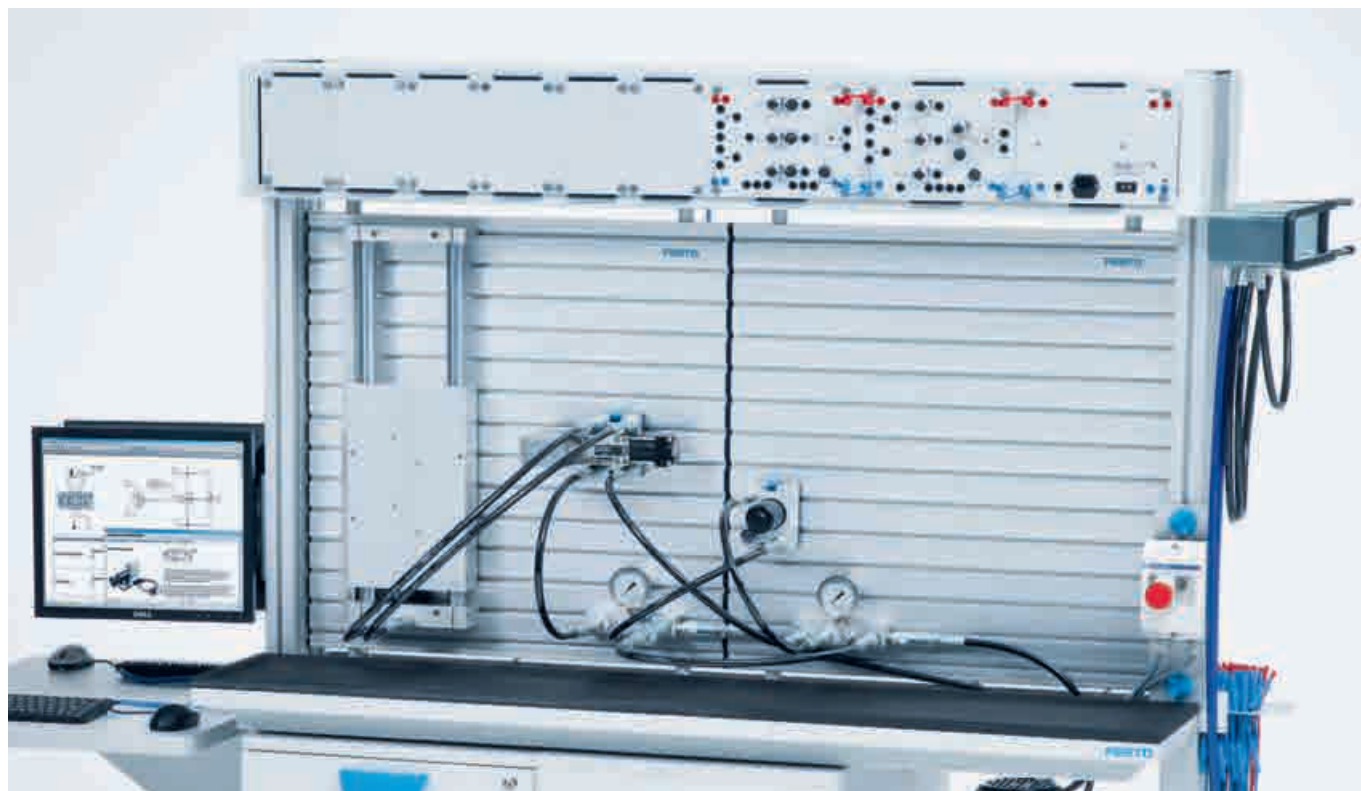

Closed-loop hydraulics, Basic Level

Hydraulic closed-loop control circuits are normally operated with continuous valves. A control valve with integrated electronics, linear characteristic curve (volumetric flow to control piston position), and zero overlap makes commissioning easy and provides good results in the closed-loop control circuit.

Training content

Position control circuits:

- Characteristic curve of a displacement sensor
- Flow rate characteristics of a continuous directional control valve
- Linear unit as a controlled system for position control
- Designing and commissioning a position control circuit
- Lag errors in the position control circuit
- Position control with a changed controlled system
- Commissioning a position control circuit with disturbances
- Characteristics and transition functions of a status controller
- Parameterizing a status controller

Pressure control circuits:

- Characteristic curve of a pressure sensor
- Controlled system for pressure control
- Characteristics of a PID controller board

- Transition function of a P controller
- Control performance of a pressure control circuit with P controller
- Transition functions of I and PI controllers
- Transition functions of D, PD and PID controllers
- Empirical parameterization of a PID controller
- Parameterizing using the Ziegler-Nichols method
- Changed controlled system with disturbances

Controllers in hydraulics:

- Controlled systems with and without compensation
- Low-delay hydraulic controlled systems
- First, second, and third order hydraulic controlled systems
- Classifying controlled systems according to their step response
- Operating point and controller amplification
- Discontinuous controllers
- Block diagrams for discontinuous and continuous controllers
- P, I, D, PI, PD and PID controllers

- Status controllers
- Selecting the controller structure
- Disturbance reaction and control factor
- Designing control circuits
- Hydraulic, mechanical and electrical controllers
- Analog and digital controllers
- Selection criteria for controllers

Valves and measuring systems:

- Designation, circuit symbols and function of continuous directional control valves
- Stationary characteristics and dynamic behavior of continuous directional control valves
- Function, design, and mode of operation of a pressure regulating valve
- Pressure control with a directional control valve
- Mode of operation and interface of a measuring system

Complete equipment set TP 511 in equipment tray 8028723

The most important components at a glance:

1	1x PID controller	162254
2	1x Status controller	162253
3	2x Pressure sensor	525964
4	1x Pressure gauge	152841
5	1x Hydraulic motor	152858
6	1x Flow sensor	567191
7	1x Pressure filter	548609
8	1x Flow control valve	152842
9	1x Shut-off valve	152844
10	2x 4-way distributor with pressure gauge	159395
11	2x T-distributor	152847
12	1x 4/3-way regulating valve	567269
13	1x Linear drive	8028726
14	2x Weight, 5 kg, for linear drive	34065

Necessary accessories, also order:

4x	Hose line with quick release couplings, 600 mm	152960
3x	Hose line with quick release couplings, 1000 mm	152970
2x	Hose line with quick release couplings, 1500 mm	159386
2x	Hose line with quick release couplings, 3000 mm	158352
1x	Pressure relief unit	152971
1x	Function generator	152918
3x	Cable BNC – 4 mm	152919
1x	Cable BNC – BNC	158357
1x	T-connector BNC	159298
	4 mm Safety laboratory cables → Page 155	
	Digital multimeter	8040005
	Aluminum profile plate → Page 39	
	Digital storage oscilloscope → Page 154	
	Hydraulic power pack $q > 3.5$ l/min → Pages 148 – 149	
	Power supply unit for mounting frame → Page 155	

Also order:

Workbook



The 20 exercises in this book are used to introduce the fundamentals of analog closed-loop hydraulics: pressure and position control with PID controllers, and position control with status controllers. For extra task number 21, which deals with position control with disturbance variables and an active load, the cush-

ioning cylinders for linear drives (order no. 152295), three additional tubing lines with quick connection coupling and a shut-off valve (order no. 152844) are required. These are not included in the scope of delivery.

The workbook contains:
 – Sample solutions, training notes
 – Worksheets for students

Campus license (→ Page 19):

de	94460
en	94469
es	94368
fr	94348

Supplementary media

- FluidSIM®
- FluidLab®
- WBT Hydraulics
- WBT Electrohydraulics
- WBT Open- and closed-loop control
- Textbook: Proportional hydraulics, Basic level
- Hydraulics poster set

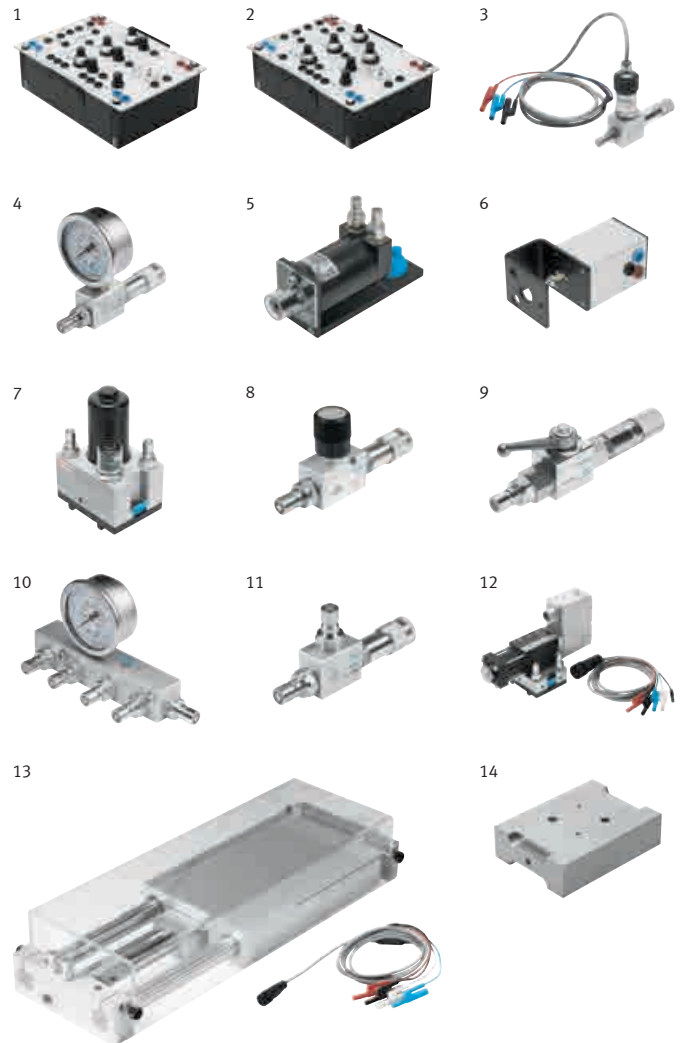

BIBB hydraulics equipment sets

Suitable for BIBB hydraulics course, lessons A – Z

BIBB hydraulics equipment set – basic equipment set

Matches BIBB hydraulics instruction course, exercises A-Z

Training content

The 21 exercises in the BIBB hydraulics course teach the fundamentals of hydraulic control engineering. Topics covered: hydraulic power pack, directional control valves and drives, shut-off and flow control valves, pressure regulators and pressure switches, hydraulic reservoirs, application switches, hoisting a load, Grätz switches, neutral circulation of the pump delivery, commissioning, and maintenance.

Basic equipment set in the equipment tray **8025069**

The most important components at a glance:

1x Differential cylinder 16/10/200 with cover	572746
1x 3-way pressure reducing valve	544337
1x 2-way flow control valve	544338
1x Flow control valve	152842
1x One-way flow control valve	152843
4x T-distributor	152847
1x Diaphragm accumulator with shut-off block	152859
1x Weight, 9 kg, for cylinder	152972
1x Pressure switch, electronic	548612
1x Flow sensor	567191
2x Hydraulic motor	152858
1x Pressure relief valve, piloted	8025067
1x Pressure relief valve	544335
1x Non-return valve, delockable	544339
1x Shut-off valve	152844
2x Non-return valve, 0.05 MPa opening pressure	548617
2x Non-return valve, 0.6 MPa opening pressure	548618
2x Pressure gauge	152841
2x 4-way distributor with pressure gauge	159395

Necessary accessories, also order:

6x Hose line with quick release couplings, 600 mm	152960
4x Hose line with quick release couplings, 1000 mm	152970
4x Hose line with quick release couplings, 1500 mm	159386
Pressure relief unit	152971
4 mm Safety laboratory cables → Page 155	
Digital multimeter	8040005
Aluminum profile plate → Page 39	
Hydraulic power pack → Pages 148 – 149	
Protective cover for weight, 9 kg → Page 143	
Tabletop power supply unit → www.festo-didactic.com	
Power supply unit for mounting frame → Page 155	

Possible combinations (only available when ordered as combination)

- Basic equipment set and electro-hydraulics equipment set extension (Order no. 8025069 and order no. 8025073)
- Basic equipment set and hand lever valve equipment set extension (Order no. 8025069 and order no. 8025072)
- Basic equipment set and hand lever valve equipment set extension and electro-hydraulics equipment set extension (Order no. 8025069 and order no. 8025072 and order no. 8025073)

BIBB hydraulics equipment set – electro-hydraulics extension set

Required for the BIBB hydraulics instruction course, exercises A-Z

When combined with the BIBB basic equipment set (order no. 8025069), the electro-hydraulics extension set covers all the devices required to complete the BIBB hydraulics instruction course tasks A – Z.

Electro-hydraulics equipment set extension **8025073**

The most important components at a glance:

1x 4/2-way solenoid valve, spring return	544346
1x 4/3-way solenoid valve, closed mid-position	544347
1x 4/3-way solenoid valve, bypass mid-position (P → T)	544349
1x 4/3-way solenoid valve, relieving mid-position (AB → T)	544348
2x Relay, three-fold	162241
1x Signal input, electrical	162242
1x Time relay, two-fold	162243
1x Proximity sensor, inductive, M12	548643

BIBB hydraulics equipment set – hand lever valve extension set

Optional for the BIBB hydraulics instruction course, exercises without electro-hydraulics

When combined with the BIBB basic equipment set (order no. 8025069), the hand lever valve extension set covers all the devices required to complete the BIBB hydraulics instruction course, except for the electro-hydraulics section of the course.

Hand lever valve extension set **8025072**

The most important components at a glance:

1x 4/2-way hand lever valve, spring return	544342
1x 4/3-way hand lever valve, closed mid-position, detenting	544343
1x 4/3-way hand lever valve, bypass mid-position (P → T), detenting	544345
1x 4/3-way hand lever valve, relieving mid-position (AB → T), detenting	544344

Recommended training media

- WBT Hydraulics
- Design and simulation program FluidSIM® Hydraulics

Also order:

BIBB hydraulics instruction course

(on request)

Equipment set TP 800 – Mobile hydraulics

From basic principles to mobile machine

Mobile hydraulics from Festo Didactic

Mobile hydraulics has a range of specific features compared to conventional industrial hydraulics. These are normally taught directly on a vehicle. But what if the components or the vehicle are not accessible or the entire system is too complex for teaching purposes?

Simplified

In contrast to a vehicle, with a learning system each hydraulic subsystem can be separately and individually constructed and examined. And measured values can be recorded almost everywhere for improved understanding.

Accessible

While in a vehicle there is usually little room and access is restricted to qualified personnel, the elements of a learning system are manageable, easy to identify and fault-tolerant.

Clean

Work on a vehicle usually means dealing with dirt and unpleasant weather. A learning system is clean and ergonomic.

With the mobile hydraulics equipment set, Festo Didactic closes the gap between the basic principles of hydraulics and hydraulic systems on a vehicle.

For an ideal introduction to mobile hydraulics, a hydraulic power unit is available, with variable displacement pump and load sensing controller and a constant displacement pump. This enables both basic and advanced levels to be taught and load simulations to be carried out with just one power unit.



Equipment sets:

Working hydraulics – Basic level

At the basic level, flow control with directional valves with different mid positions are compared in terms of their energy usage. This is done using a cylinder load simulator which, depending on the design, is capable of simulating a wide variety of different load situations.

In addition, the topics of holding and lowering the load and two 6/3 way valves for actuation of two drives are discussed using the series, parallel, and tandem circuits.

As a transition to the Working hydraulics – Advanced level, a simple load sensing controller with constant pump is implemented.

Working hydraulics – Advanced level

Here, the focus is on load sensing systems with variable displacement pump. This includes the construction, operation, and adjustment of a variable displacement pump with a load sensing controller and mobile or control block. The energy usage with flow control, open center load sensing, and closed center load sensing with a variable displacement pump can then be compared.

Remote control and hydraulic pilot control of mobile blocks can also be discussed and developed. In addition, the effects of upstream and downstream pressure balances can be tested.

Hydrostatic steering system

The working hydraulics can also be extended with a steering system. This teaches the construction and functioning of a hydrostatic steering system, with typical shock and suction valves and double-rod cylinders.

The influence and effect of loads on the steering cylinder are investigated. Combinations of working hydraulics and a steering system based on different priorities can also easily be set up. This illustrates the effect of steering activity on the downstream working hydraulics.

Equipment set TP 801 – Basic level

Mobile hydraulics – Working hydraulics 1

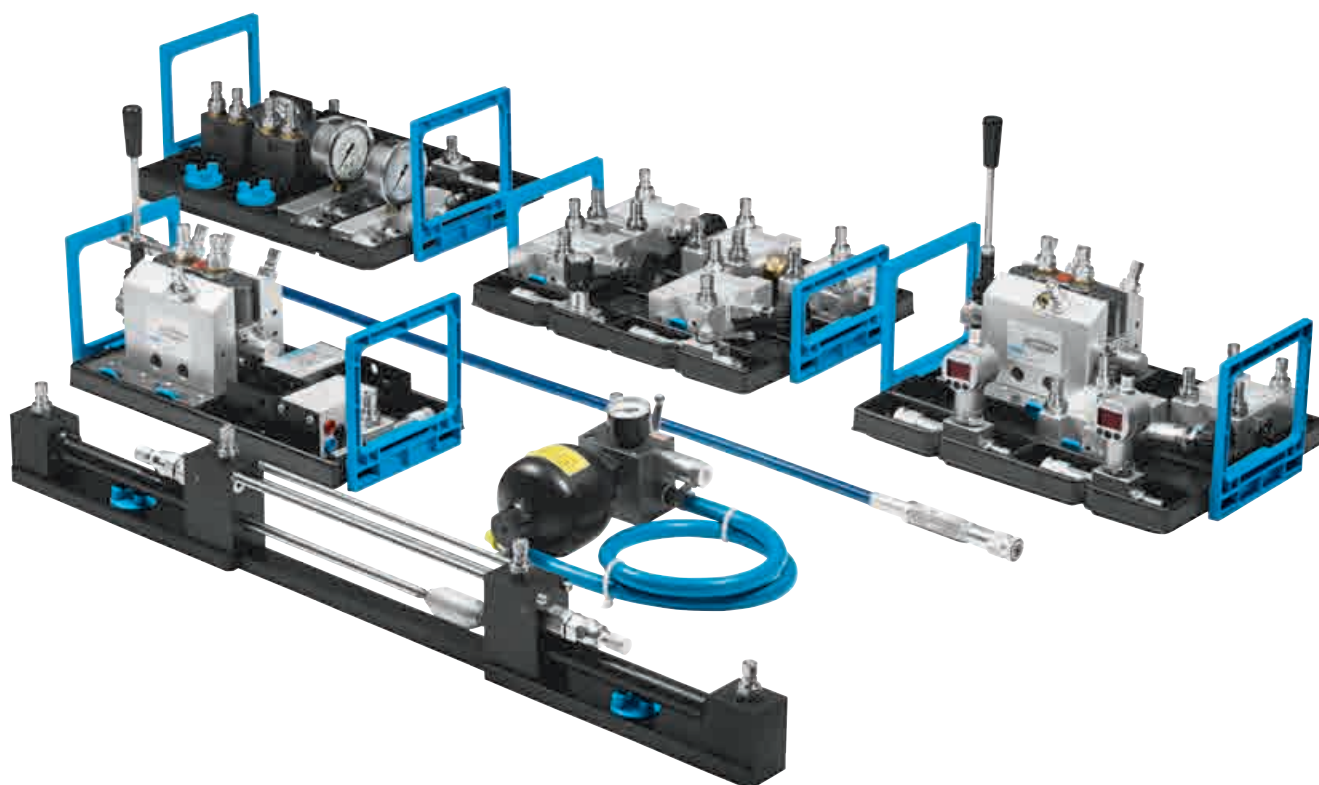

Mobile hydraulics from Festo Didactic

Mobile hydraulics has a range of specific features compared to conventional industrial hydraulics. Training content is therefore usually explained and demonstrated directly on the vehicle.

But what if the hydraulic components being explained or the vehicle are not accessible or the system is too complex for teaching purposes?

Festo Didactic's new training system closes the gap between the basic principles of hydraulics and the hydraulic systems on a vehicle.

Complexity clarified

The new training packages for mobile hydraulics take components which often appear in vehicles as highly integrated, functional modules and present them as separate, individual elements with unique symbols and clear terminal identification codes.

The teaching principle behind this is that of guiding students step-by-step from a simple component to a complex, complete picture, with practical demonstrations. The universal compatibility of the single elements allows them to be used for other function units, making this equipment set highly flexible.

Fully compatible

With uniform interfaces and a modular structure, it is possible to put together even quite complex, entire systems. All mobile hydraulics elements are compatible with the current Festo Didactic equipment sets for hydraulics fundamentals, electrohydraulics, proportional, and closed-loop hydraulics.

However, it is the double pump power unit with a pressure-limited constant displacement pump, and variable displacement pump with load sensing control, which forms the basis for the perfect training station and workstation. It also allows assembly of the load sensing system with TP 803.

Alternatively, it is possible to use a hydraulic power unit with a constant displacement pump and a volumetric flow rate of about 4 l/min for TP 801 and TP 802.

TP 801 – training content

Many vehicles and applications make use of constant displacement pumps which continue to provide volumetric flow even when no hydraulic power is required. In TP 801, the energy usage of different systems – also when under load – is compared and assessed. Systems with multiple consuming devices are set up, connected in parallel, tandem, and series, and examined in terms of characteristics, such as priority, flow rate distribution, and pressure dependency.

The training also looks into the basics of holding the load with poppet valves and lowering the load with counter pressure and a counterbalancing valve.

Complete equipment set TP 801 in equipment tray 574161

The most important components at a glance:

1	1x Counterbalance valve	572149
2	1x Pressure compensator for open center load sensing	572123
3	1x 3-way pressure reducing valve	544337
4	2x Pressure relief valve	544335
5	1x Flow control valve	152842
6	1x Non-return valve, 0.6 MPa opening pressure	548618
7	1x Shuttle valve	572122
8	1x Double non-return valve, delockable	572151
9	1x Shut-off valve	152844
10	2x 6/3-way proportional hand lever valve	572141
11	1x Loading unit/cylinder load simulator	572145
12	1x Diaphragm accumulator with shut-off block	152859
13	2x Hydraulic motor	152858
14	2x 4-way distributor with pressure gauge	159395
15	3x T-distributor	152847
16	2x Pressure switch, electronic	548612
17	2x Flow sensor	567191

Necessary accessories, also order:

10x	Hose line with quick release couplings, 600 mm	152960
4x	Hose line with quick release couplings, 1000 mm	152970
2x	Hose line with quick release couplings, 1500 mm	159386
2x	Digital multimeter	8040005
	4 mm Safety laboratory cables → Page 155	
	Hydraulic power pack → Pages 148 – 149	
	Power supply unit for mounting frame → Page 155	

The equipment tray

The training package is supplied with an equipment tray, which also fits in the drawers of the workstations. A fixed drawer unit for mobile hydraulics with two drawers is recommended for particularly large components.

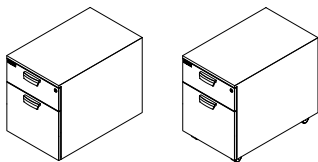

Fixed drawer unit for mobile hydraulics (2 drawers)

Order no. **574153**

Wheeled drawer unit for mobile hydraulics (2 drawers)

Order no. **574152**

The media on offer for TP 801

- Workbook for mobile hydraulics TP 800
- Diagnostic system TP 810 with FluidLab®-M
- Designing and simulating with FluidSIM®
- WBT Hydraulics
- WBT Electrohydraulics
- Hydraulics poster set

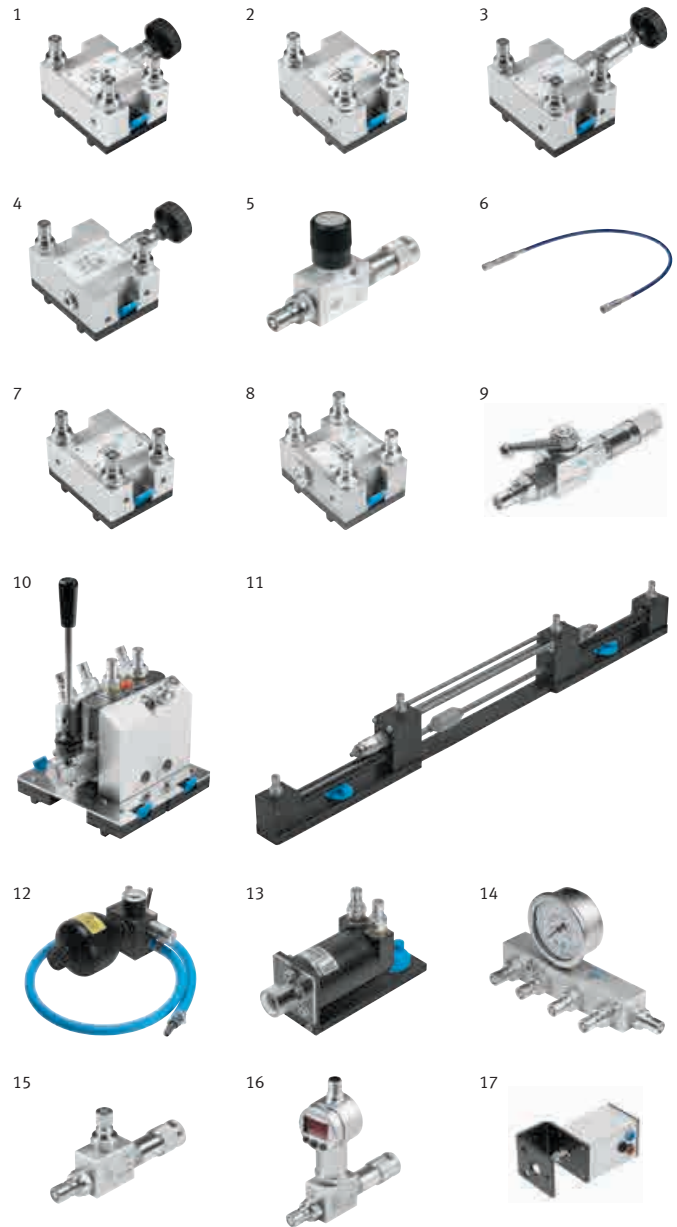

Supplementary equipment set

Mobile hydraulics

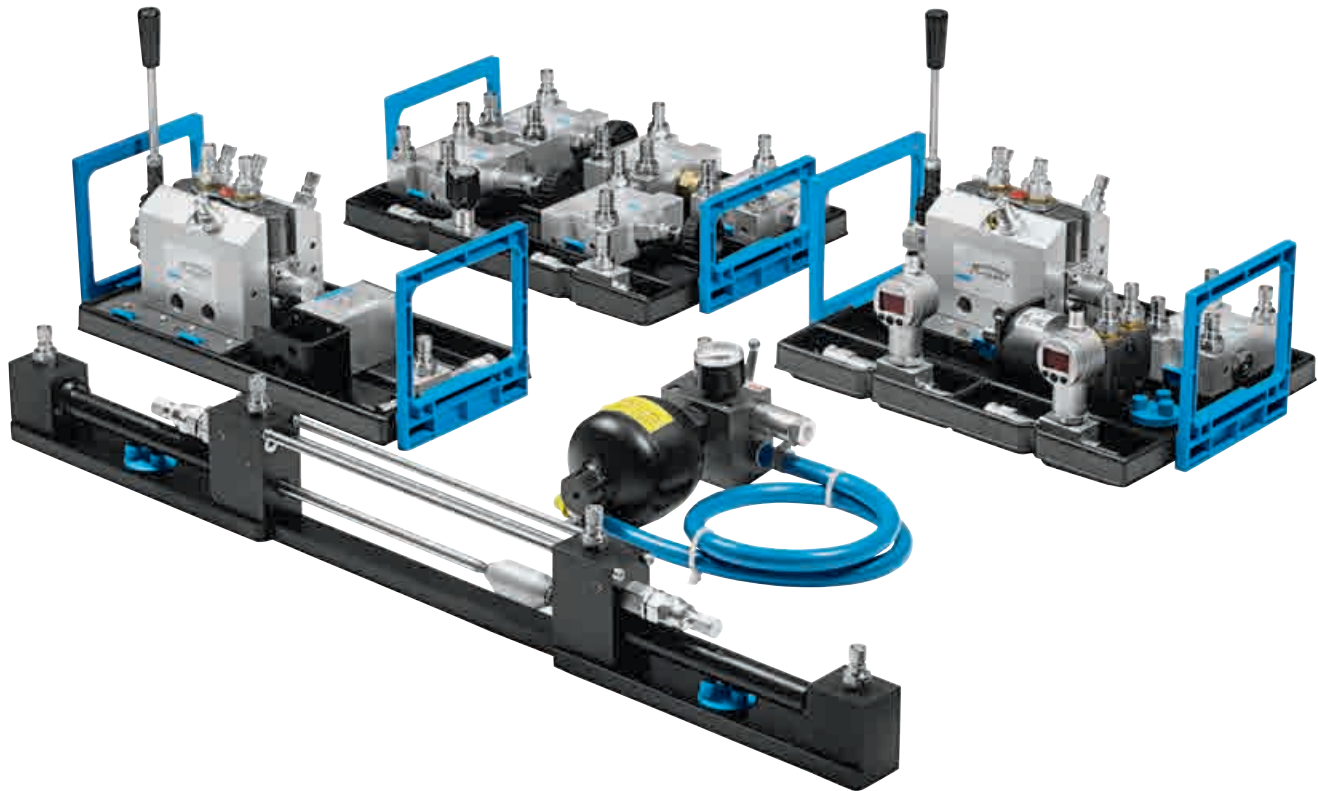

Supplementary equipment set from Hydraulics, Basic level TP 501 to Mobile hydraulics, Working hydraulics 1 TP 801

The supplementary equipment set extends TP 501 (order no. 573035) to form TP 801. The necessary accessories from TP 801 are required in order to carry out the exercises. Supplements are available on request for other/older equipment sets.

For training content, see Equipment set, Mobile hydraulics, Working hydraulics 1 TP 801.

Complete supplementary equipment set TP 501 – TP 801 in equipment tray **574160**

The most important components at a glance:

1x Counterbalance valve	572149
1x Pressure compensator for open center load sensing	572123
1x 3-way pressure reducing valve	544337
1x Pressure relief valve	544335
1x Flow control valve	152842
1x Shuttle valve	572122
1x Double non-return valve, delockable	572151
2x 6/3-way proportional hand lever valve	572141
1x Diaphragm accumulator with shut-off block	152859
1x Loading unit/cylinder load simulator	572145
1x Hydraulic motor	152858
2x T-distributor	152847
2x Pressure switch, electronic	548612
1x Flow sensor	567191

Mobile hydraulics TP 800

Workbook



The workbook contains 21 project exercises designed for equipment sets TP 801, TP 802 and TP 803 together with the corresponding exercise sheets and sample solutions. It thus provides a comprehensive course companion, conveying the essential knowledge and basic principles of the hydraulic systems of mobile machines.

The workbook contains:

- Basic information
- Exercise sections comprising project exercises, and sample solutions for TP 801, TP 802 and TP 803
- Training notes
- Multimedia CD-ROM with supplementary media
- Worksheets for students

The basic level contains the following topics:

- Definition of terms and basic principles of hydraulics
- Closed hydraulic circuit
- Load-sensing systems and variable displacement pumps
- Flow divider
- Mobile control blocks
- 6/3-way proportional valves and valve configurations
- Pressure balances
- Holding and lowering loads
- Hydraulic pilot control (joystick)
- Priority valves
- Steering systems

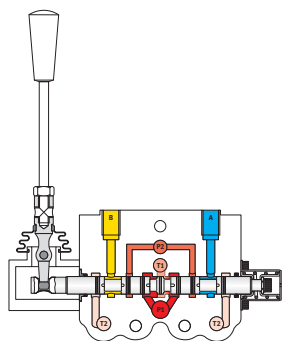

Exercise section TP 801 Working hydraulics 1

This training section, made up of nine project exercises, is designed for the equipment set TP 801.

Each project exercise begins by presenting the training objectives. Next, the vehicle or application under discussion is presented. Parameters are provided to ensure a uniform starting point, and the project goal ensures a structured approach.

Energy usage

- Of flow control
- Of open center load sensing
- Of a proportional valve (supply)
- Of a proportional valve (supply and discharge) with and without open center load sensing
- Of a proportional valve with pump bypass with and without loaded cylinder

Holding load, lowering load

- Holding load (piloted non-return valves)
- Lowering load (counter pressure)
- Lowering load (counterbalancing valve)

Circuits with multiple loads

- Features of parallel connection
- Features of tandem connection
- Features of series connection

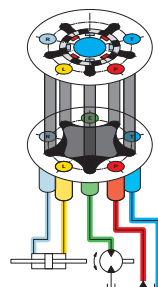

Exercise section TP 802 Hydrostatic steering system

This training section, made up of five project exercises, is designed for the equipment set TP 802.

During all project exercises, trainees set up a circuit as per the instructions and the relevant circuit diagram, and carry out measurements and calculations. Each project exercise ends with a series of questions to test trainees' understanding. The measurements, calculations, and answers can then be compared with the sample solutions and discussed.

Basic principles of hydrostatic steering

- Structure of a steering system with through-rod cylinders
- Structure of a steering system with two differential cylinders
- Displacement of the steering valve
- Emergency steering characteristics of the steering valve
- Loads and overloads in the steering system
- Torque dependency of the steering valve
- Priorities of the steering system and secondary loads

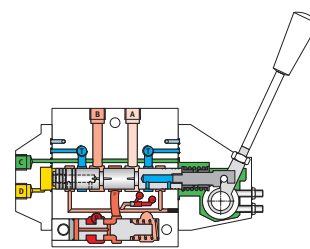

Exercise section TP 803 Working hydraulics 2

This training section, made up of seven project exercises, is designed for the equipment set TP 803.

The content builds on the training content of TP 801, Working hydraulics 1 and expands it to include the complex topic of systems with a variable displacement pump with load sensing control. However, the complexity is kept to a manageable level because the project exercises are progressive, each building on the one before.

Load-sensing systems

- Design and function of a control block
- Control block with closed center load sensing
- Control block with two loads
- Flow rate limitation on the control block
- Pilot control of a control block
- Dependencies of load and flow
- Functioning of an upstream pressure balance
- Pressure compensation for load sensing
- Characteristics of upstream pressure balances when there is more than one load
- Characteristics of downstream pressure balances when there is more than one load

L. Unan, U. Schedel, C. Löffler
Edition 2013, 540 pages, colour, in folder.

Campus license (→ Page 19):

de	574165
en	574166
es	8042424

Equipment set TP 802 – Advanced level

Mobile hydraulics – Hydrostatic steering system

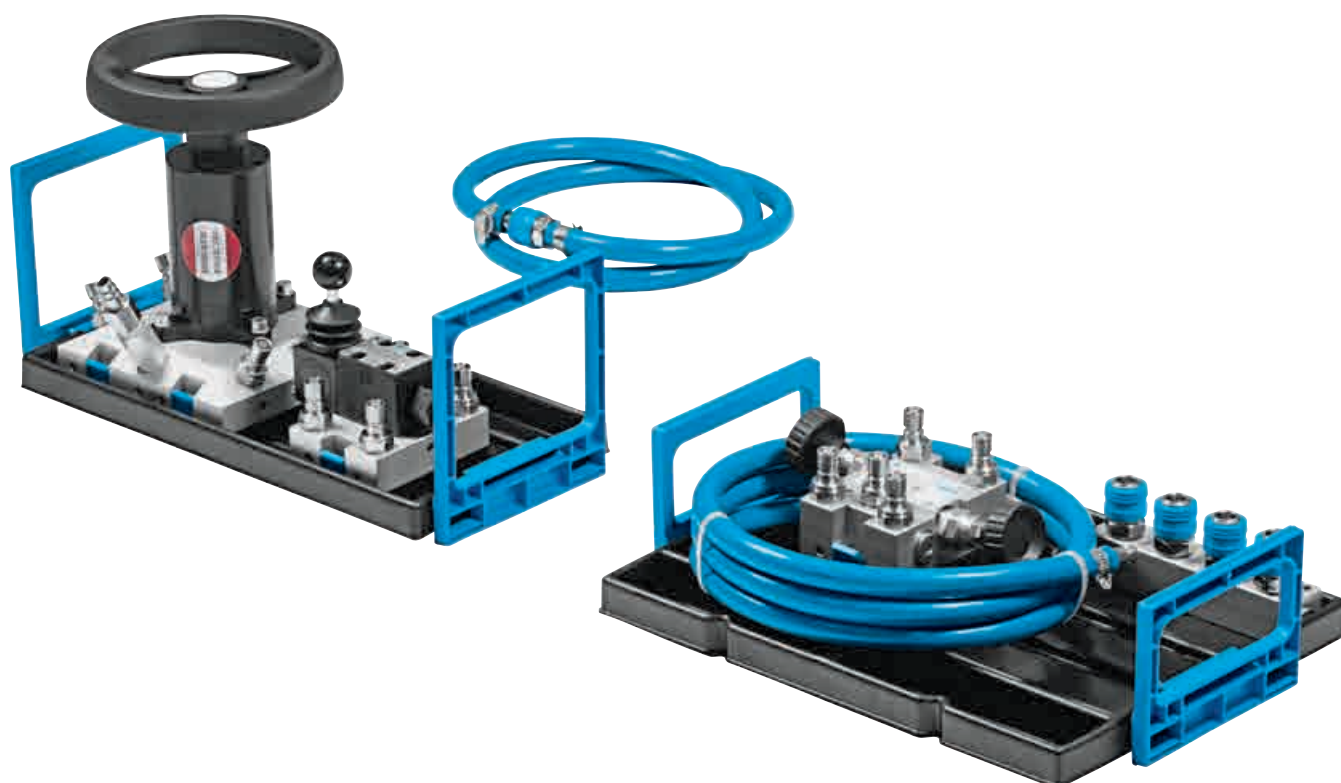

Hydrostatic steering system

Hydrostatic steering is an essential subsystem in many mobile machines and is especially well-suited to managing high steering forces.

The number and design of the components are specifically adapted to the projects in the workbook. This ensures a maximum return on the training with minimum effort.

For multiple use

As with all Festo Didactic training packages, including mobile hydraulics, all components are designed to be used as parts of a single, compatible system. This means that many parts at basic level can also be used for experiments at advanced levels. Long-term maintenance of the interfaces is also an important part of the design, whether mechanical with Quick-Fix, hydraulic with low-leakage couplings, or electrical with safety plug technology.

Components and accessories from the equipment set TP 801 are required to carry out the projects.

Safety first!

Safety in the use of our training system is top priority. Many mobile hydraulics elements are not designed to be pressure resistant. This is why our oil return ports use an open coupling system. Students should nonetheless be made fully aware of safety matters. Making sure connections are correct will minimize impact on resources and the environment.

TP 802 – training content

TP 802 promotes the practical testing and technical measurement of the structure and method of operation of a hydrostatic steering system, comprising a steering valve, anti-shock and anti-cavitation valves, steering cylinder(s), constant-displacement pump, and (if needed) secondary loads.

The basics include the structure of different steering systems with through-rod and differential cylinders, and determining the displacement and the torque dependencies of the steering unit. In addition, emergency steering characteristics are explored and tested. An overload is applied to the system, its behavior is analyzed and anti-shock valves are set accordingly. The steering system's priority over a secondary load also forms part of this training package.

Complete equipment set TP 802 in equipment tray **574162**

The most important components at a glance:

1	1x Steering unit (Orbitrol)	572146
2	1x Shock and anti-cavitation valve	572148
3	1x 4/3-way hand lever valve, relieving mid-position (AB → T), detenting	544344
4	1x Tubing line for unpressurized return	573024
5	1x 4-way return header, unpressurized	573026

Necessary accessories, also order:

9x	Hose line with quick release couplings, 600 mm	152960
4x	Hose line with quick release couplings, 1000 mm	152970
3x	Hose line with quick release couplings, 1500 mm	159386
2x	Digital multimeter	8040005
4 mm Safety laboratory cables → Page 155		
Hydraulic power pack → Pages 148 – 149		
Power supply unit for mounting frame → Page 155		

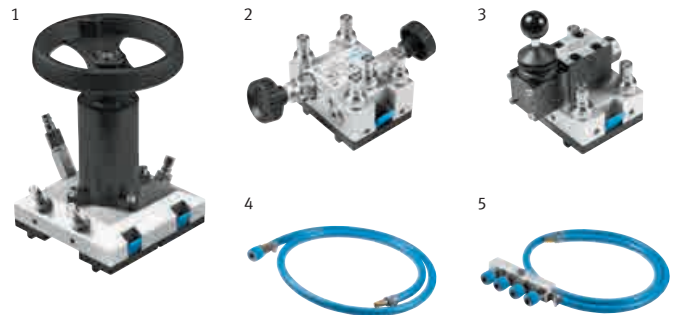

The media on offer for TP 802

- Workbook for mobile hydraulics TP 800
- Diagnostic system TP 810 with FluidLab®-M
- Designing and simulating with FluidSIM®
- WBT Hydraulics
- WBT Electrohydraulics
- Hydraulics poster set

The workstation system

Learnline has a modular design and offers an almost unlimited range of configuration possibilities for the Learnline workstation, such as the table extension for PC-assisted measurement with TP 810 and FluidLab®.

Learnline has a profile surface area of 1400 x 700 mm per side – lots of room for large components and complex circuits.

Quality isn't compromised, as its construction and functionality are the very best. The torsionally rigid design and the high-quality coating on the work surface and frame guarantee a long service life despite high loads. Learnline can handle the hard daily lesson routine, as well as a vibrational load during the hydraulic position control.

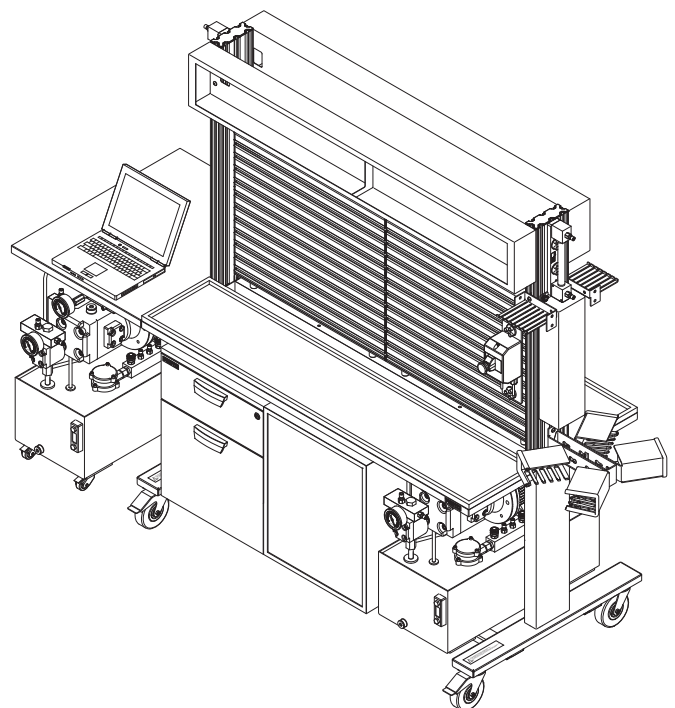

Equipment set TP 803 – Advanced level

Mobile hydraulics – Working hydraulics 2

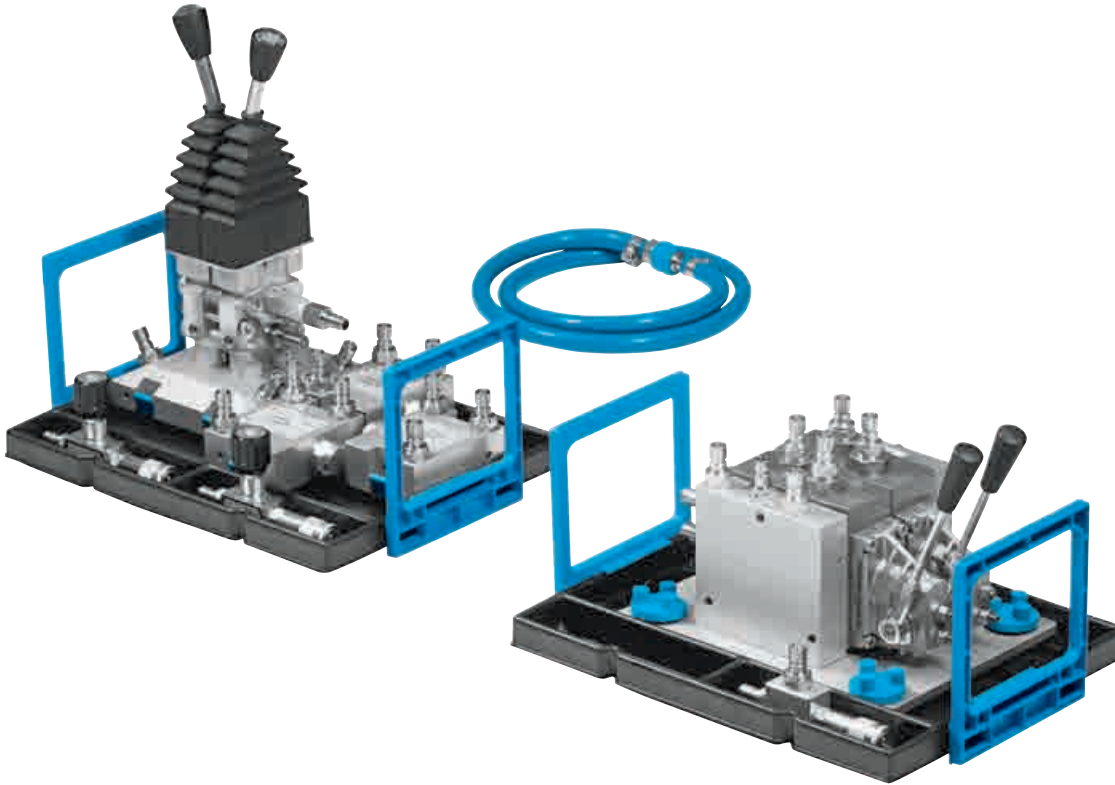

Working hydraulics 2

The challenge for the efficient operation of machines is how to handle frequently changing loads and fluctuating speeds during the operation cycle.

Constant displacement pump systems generally have a very poor degree of efficiency in such cases, as they are always designed for the highest, most likely pressure and flow rate.

Load-sensing systems are different. Both the pressure and the flow rate are adapted to the actual needs. This requires a variable displacement pump with a load-sensing (LS) controller, as well as valves with the right type of control paths for load feedback to the pump controller.

System behavior under load

In practical applications, the challenge is to handle continuously changing large loads reliably and efficiently. To reflect this challenge properly in the training system, we have developed a cylinder load simulator which allows an extremely wide range of load types, even with the TP 801 set.

An active or passive hydraulic counteracting force is applied to a combination of two differential or through-rod cylinders.

By doing away with large working loads and integrating an overload safeguard, the cylinder load simulator is not just highly flexible, but also safe to use and extremely manageable.

TP 803 – Working hydraulics advanced level training content

The advanced level focuses on the load-sensing system with variable displacement pump, control block, pilot control, and up to two loads.

Components and accessories from the equipment sets TP 801 and TP 802 are required to carry out the projects.

The content:

- Design, mode of operation, and setting of a variable displacement pump with load sensing controller and control block.
- Comparing and assessing the energy usage of flow control, open center load sensing and closed center load sensing with a variable displacement pump.
- Remote control and hydraulic pilot control of control blocks.
- Characteristics of load sensing systems with upstream and downstream pressure balances (flow distribution independent of load pressures).

Complete equipment set TP 803 in equipment tray 574163

The most important components at a glance:

1	1x Pilot valves (joystick), 2x2-channel	572147
2	1x Mobile valve block, Load sensing	572144
3	1x Pressure compensator, upstream (pre)	573023
4	2x Pressure compensator, downstream (post)	572741
5	2x Flow control valve	152842
6	1x T-distributor	152847
7	1x Tubing line for unpressurized return	573024

Necessary accessories, also order:

10x	Hose line with quick release couplings, 600 mm	152960
6x	Hose line with quick release couplings, 1000 mm	152970
3x	Hose line with quick release couplings, 1500 mm	159386
2x	Digital multimeter	8040005
	4 mm Safety laboratory cables → Page 155	
	Hydraulic power pack → Pages 148 – 149	
	Power supply unit for mounting frame → Page 155	

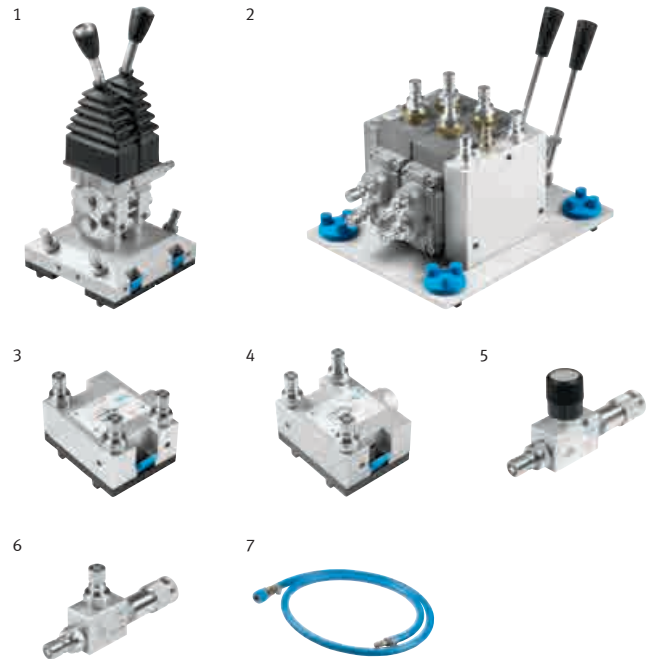

The hydraulic power unit

The power unit used for the mobile hydraulics training packages is a variable and constant displacement pump combination. The constant displacement pump is ideal both for the basic principles of hydraulics and electrohydraulics and for the mobile hydraulics sets TP 801 and TP 802. With TP 803, the focus shifts to the variable displacement pump with LS controller, with the function of the constant-displacement pump now being applied to active hydraulic loads on the cylinder load simulator.



The media on offer for TP 803

- Workbook for mobile hydraulics TP 800
- Diagnostic system TP 810 with FluidLab®-M
- Designing and simulating with FluidSIM®
- WBT Hydraulics
- WBT Electrohydraulics
- Hydraulics poster set

Equipment set TP 810 – Advanced level

Diagnostic system FluidLab®-M: Measurement – Visualization – Analysis



A greater understanding of diagnostic systems

System diagnostics, condition monitoring, and energy efficiency are becoming more important all the time.

A fluid power system can only be optimally set if measurements are taken at the correct points. The correct conclusions must then be drawn from the measurement data. However, with dynamic system conditions, measuring techniques such as the use of a pressure gauge are pushed to their limits. That is why permanent measured data acquisition with visualization of measurement curves is necessary. Servicing and maintenance personnel then have access to crucial information for the tasks at hand and settings required. FluidLab®-M is the universal measuring tool for all pneumatic and hydraulic training packages.

The new FluidLab-M®

Do you want the measuring system for your fluid power circuits, processes, or systems to be simple but high quality? To start with, any number of sensors with voltage output and connected to a PC via EasyPort, can be adapted to the measurement software in a few simple steps. Your sensor settings, designations, and ranges of values are stored and immediately ready to use next time. FluidLab-M® can record up to four analog and digital inputs simultaneously.

Reproducible measurement processes

Simply start the measurement and record digital and analog input and output signals. During the measurement, you can set and reset the digital outputs manually and control the analogue outputs. A reproducible, controlled measurement process is important if you want to be able to compare series of measurements. This is a particularly strong point of FluidLab®-M. The measurement process can be programmed and saved directly in a text editor using a simple programming code. For example, delay times, jump or repeat commands, and periodic analog output signals can all be programmed.

Visualization and analysis

Two display modes are available for measured-data data acquisition. One displays up to two Y-axes over time (X-axis). For example, changes in pressure and flow rate over the course of a cycle can be recorded. The other is an XY graph to record e.g., a flow control or pump characteristic; in other words, pressure over flow rate. The measured values can be saved and superimposed over other records within the software, or compared and analyzed. There are two measuring cursor and zoom and detail functions available for the purpose of analysis. Alternatively, a spreadsheet program such as Microsoft Excel can be used to open and work with the measured values.

Complete equipment set TP 810 in equipment tray **574164**

The most important components at a glance:

1	1x EasyPort USB	548687
2	1x Analog cable, parallel, 2 m	529141
3	1x I/O data cable with SysLink connectors (IEEE 488) at both ends, 2.5 m	34031
4	1x Universal connection unit, digital (SysLink)	162231
5	1x Quick-Fix screw adapter	549806
6	1x Connection unit, analog	567232
7	1x FluidLab-M Single license, de/en	573029

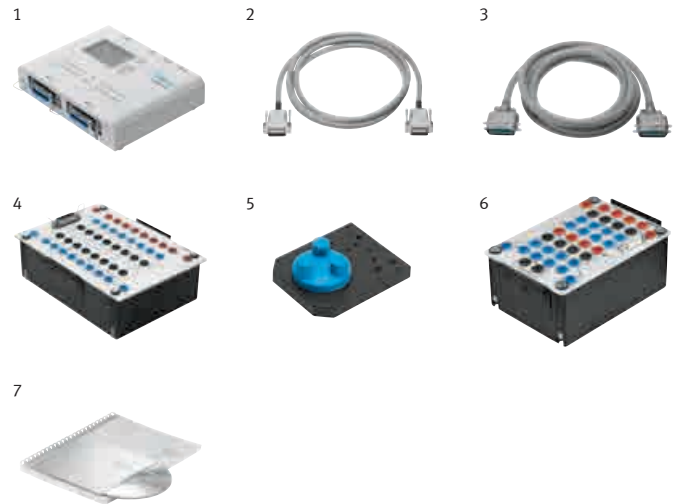

System requirements

- PC with Windows 7/8/10
- Pentium® III or equivalently
- 2 GB RAM
- CD-ROM disk drive
- USB 2.0 or serial interface
- 1280 x 1024 pixels
- NI LabView 2012 Runtime (included in scope of delivery)

The media on offer for TP 810

- Workbook for mobile hydraulics TP 800
- Designing and simulating with FluidSIM®
- WBT Hydraulics
- WBT Electrohydraulics
- Hydraulics poster set

Measurements can be carried out with any sensor with voltage output and 4 mm safety plug. Sensors are not included in scope of delivery.

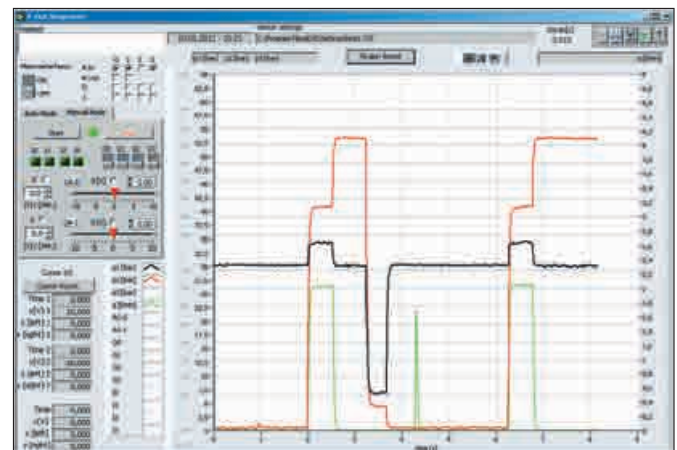

Components

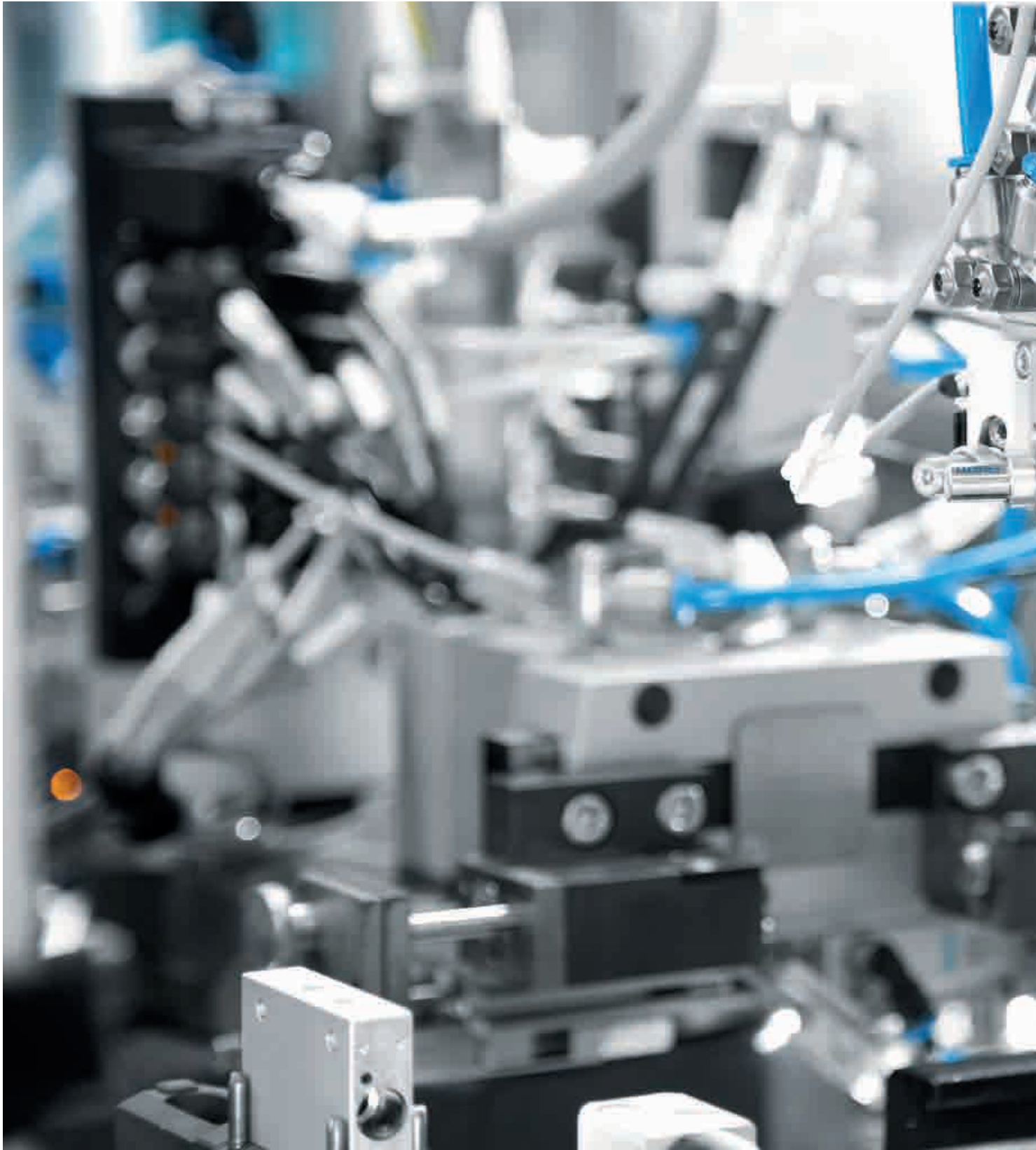



Pneumatics Components	124
Directional control valves	124
Paths and pressure valves	126
Power and shut-off valves	127
Control valves	128
Drives/actuators	130
Hosing, distributing	133
Sensors/Measuring technology	134
Accessories and optional components	136
Additional components	137
Hydraulics Components	138
Directional control valves	138
Pressure valves	140
Power/Lock valves	142
Drives	144
Accessories and optional components	148
Sensors/Measuring technology	150
Power packs	152
Additional Components	154
Measurement and control electronics	154
Sensors/Measuring technology	157
Electrical power supply	159
Organizers	160

Pneumatics

Directional control valves



1/2/3/4/5 Directional control valves, manually operated

Poppet valve – directly actuated, with spring return, quick action push/pull connector for plastic tubing PUN-4 x 0.75 for inside/outside calibrated tubes. Quick and secure click-on system for the profile plates

- Working pressure: at 600 kPa (6 bar) 6 N
- Nominal flow rate: 1(P) – 2 (A) 60 l/min
- Safety and quick mounting system

1 3/2-way-panel mounted with Pushbutton Actuator, normally closed

- Actuation: Pushbutton
- Pressure range: -95 – 800 kPa (-0.95 – 8 bar)

Order no. 152860

2 3/2-way-panel mounted valve with Pushbutton Actuator, normally open

- Actuation: Pushbutton
- Pressure range: -95 – 800 kPa (-0.95 – 8 bar)

Order no. 152861

3 5/2-way panel mounted valve with Selector Switch

- Actuation: Selector switch
- Pressure range: 0 – 800 kPa (0 – 8 bar)

Order no. 152862

4 3/2-way panel Mounted Valve with Selector Switch, normally closed

- Actuation: Selector switch
- Pressure range: 0 – 800 kPa (0 – 8 bar)

Order no. 152863

5 3/2-way panel mounted valve with lockable mushroom actuator, red, normally open

Poppet valve, directly actuated in one direction, with spring return. The valve is actuated when the red mushroom actuator is pressed. Once the actuator is released, the switching status is retained. Turning the mushroom actuator clockwise will return it to its basic setting again, with the valve set to normal position by the return spring.

- Actuation: Mushroom actuator
- Pressure range: 0 – 800 kPa (0 – 8 bar)

Order no. 152864

6/7/8 Directional control valves, mechanically operated

Seat valve, one-sided, indirectly operated, with return spring

- Actuating force at 600 kPa (6 bar) 1.8 N
- Quick action mounting system Quick-Fix

6 3/2-way roller lever valve with idle return, normally closed

The roller lever valve with idle return is actuated when the roller lever is traversed by the cam of a cylinder in a certain direction. After release of the roller lever, the valve is returned to its initial position by a return spring. When traversed in the reverse direction, the roller lever has an idle return and the valve is not actuated.

- Pressure range: 0 – 800 kPa (0 – 8 bar)

- Standard nominal flow rate: 1(P) – 2(A) 80 l/min

Order no. 152867

7/8 3/2-way roller lever valve, normally closed

The roller lever valve is actuated when the roller lever is pressed, for example, by the cam of a cylinder. After release of the roller lever, the valve is returned to its initial position by a return spring.

- Pressure range: 350 – 800 kPa (3.5 – 8 bar)

- Nominal flow rate: 1 (P) – 2 (A) 120 l/min

Order no. 152866

8 3/2-way roller lever valve, normally open

Order no. 162267

Pneumatics

Directional control valves

1/2/3/4/5/6 Directional control valves, pneumatically actuated

Directly actuated, mono- and bistable piston valve with mechanical spring return.

- Quick push-in fitting for plastic tubing PUN-4 x 0.75 or for internally or externally calibrated tubing types
- Symbol, port identification, and connection position to DIN ISO 1219
- Pilot pressure: 150 – 1,000 kPa (1.5 – 10 bar)
- Operating pressure:
 - 90 – 1,000 kPa (-0.9 – 10 bar)
- Suitable for vacuum and reverse operation
- Quick action mounting system Quick-Fix

1 3/2-way valve, pneumatically actuated on one side

Order no. **576302**

2 5/2-way pneumatic valve, pneumatically actuated, one side

Order no. **576307**

3 5/2-way double pilot valve, pneumatically actuated on both sides

Order no. **576303**

4 5/3-way valve, mid-position pressurized

Order no. **576305**

5 5/3-way valve, mid-position exhausted

Order no. **576306**

6 5/3-way valve, mid-position closed

Order no. **576304**

7/8/9/10/11 Directional control valves, electromagnetically operated

Pilot actuated, single solenoid piston spool valve with pneumatic spring return, non-detenting and detenting manual override, and LED.

- Electrical connection via integrated 4 mm safety sockets
- 24 V DC power supply
- Pneumatic connection via QS-4 push-in fitting
- Quick action mounting system Quick-Fix

7 2 x 3/2-way solenoid valve with LED, normally closed

- Switching time on/off 6/16 ms
- Operating pressure: 150 – 800 kPa (1.5 – 8 bar)

Order no. **567198**

8 2 x 3/2-way solenoid valve with LED, normally open

- Switching time on/off 6/16 ms
- Operating pressure: 150 – 800 kPa (1.5 – 8 bar)

Order no. **2326587**

9 5/2-way solenoid valve with LED

- Switching time on/off 7/19 ms
- Operating pressure: 250 – 800 kPa (2.5 – 8 bar)

Order no. **567199**

10 5/2-way double solenoid valve with LED

- Response time 7 ms
- Operating pressure: 150 – 800 kPa (1.5 – 8 bar)

Order no. **567200**

11 5/3-way double solenoid valve, mid position closed

- Response time 7 ms
- Operating pressure: 150 – 800 kPa (1.5 – 8 bar)

Order no. **567201**

1



2



3



4



5



6



7



8



9



10



11



Pneumatics

Directional control and pressure valves

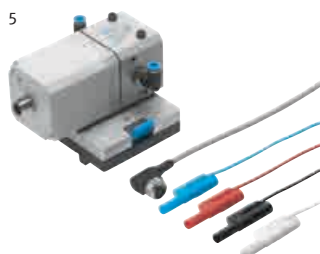
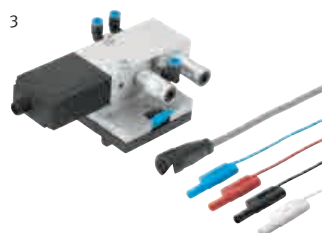

1 Electromagnetically actuated 3/2-way fast-switching solenoid valve

Normally closed single-solenoid poppet valve with mechanical spring and non-detenting manual override.

- Electrical connection with 4 mm safety plug
- Power supply: 24 V DC
- Pneumatic connection with push-in fitting QS-6
- Switching time on/off 2.3/2.8 ms
- Max. switching frequency: 280 Hz
- Operating pressure: -90 – 800 kPa (-0.9 – 8 bar)
- Safety and quick mounting system

Order no. **544312**

2 Valve terminal with 4 valve slices (MMJJ)

Valve manifold type MPA with two 5/2-way solenoid valves and two 5/2-way double solenoid valves. The solenoid coils are connected to power with safety plugs that are labelled with the coil index.

- Switching status indicator: LED
- Operating pressure: -0.9 – 10 bar
- Pilot pressure: 3 – 8 bar
- Standard nominal flow rate: 360 l/min
- Nominal operating voltage: 24 V DC
- Safety and quick mounting system

Order no. **540696**

3 5/3-way proportional valve

The proportional, directional control valve converts an analog electrical input signal into corresponding opening cross sections at the outputs.

- Operating medium: filtered, unlubricated compressed air (5 µm filtration grade)
- Nominal/maximum pressure: 600/1,000 kPa (6/10 bar)
- Max. nominal flow rate: 700 l/min
- Operating voltage: 24 V DC
- Analog setpoint voltage: 0 – 10 V DC
- Power consumption: 2 W (piston in mid-position)
- Power consumption: 20 W (max.)
- Max. hysteresis: 0.4%
- Cut-off frequency: 100 Hz
- Safety and quick mounting system

Order no. **167078**

4 Pressure regulator with pressure gauge

Control valve with pressure gauge, adjustable by lockable rotary knob, precision quick connector for plastic tubing PUN-4 x 0.75 or for internally or externally calibrated tubing types.

- Standard nominal flow rate: 110 l/min
- Max. input pressure: 1,000 kPa (10 bar)
- Control pressure: 50 – 700 kPa (0.5 – 7 bar)
- Safety and quick mounting system

Order no. **539756**

5 Proportional pressure regulator

Proportional pressure regulator with connecting cable with safety plugs for installation on profile plates. The regulator supplies pressure (0.15 – 6 bar) proportional to the input voltage (0 – 10 V).

- Supply voltage: 21.6 – 26.4 V/3.6 W
- Residual ripple: 10%
- Electrical setpoint value: 0 – 10 V
- Inlet pressure 7 – 8 bar
- Pressure regulation range: 0.15 – 6 bar
- Flow rate: 600 l/min
- Safety and quick mounting system

Order no. **539779**

Pneumatics

Power and shut-off valves

1 Flow control valve

- Standard nominal flow rate: 85 l/min
- QS-4 connection

Order no. **193972**

2 Non-return valve

- Standard nominal flow rate: 136 l/min
- QS-4 connection

Order no. **153462**

3 Non-return valve, delockable

As long as a pilot signal is applied to the non-return valve, compressed air should flow to and from the cylinder. When the pilot signal is cancelled, the non-return valve should shut off the cylinder exhaust air, thereby stopping the cylinder motion. The valve should be suitable for use for positioning and braking functions.

- Operating pressure: 0.5 – 10 bar
- Standard nominal flow rate: 108 l/min

Order no. **540715**

4/5/6 One-way flow control valve

The one-way flow control valve is a combination of a flow control valve and a nonreturn valve. The cross-section of the restrictor can be set by means of a knurled screw.

- Design: One-way flow control valve
- Pressure range: 20 – 1000 kPa (0.2 – 10 bar)
- Nominal flow rate in flow control direction: 0 – 85 l/min
- Nominal flow rate in open direction: 100 – 110 l/min

Order no. **193967**

5 One-way flow control valve

- Safety and quick mounting system

Order no. **560159**

6 One-way flow control valve

- Safety and quick mounting system

Order no. **152881**

7 Second one-way flow control valve

For controlling the flow rate. Flow control screws for continuous flow rate adjustment in either flow direction. In the reverse direction, the air flows through a full cross-section check valve.

- Push-in fitting via QS-4 pneumatic connection
- Standard nominal flow rate in flow control/non-return direction: 90/70 l/min

Order no. **548634**

8 Quick-exhaust Valve

Quick-exhaust valve with built-in silencer.

- Design: Poppet valve
- Nominal flow rate: 1 – 2: 300 l/min
- Nominal flow rate: 2 – 3: 390 l/min

Order no. **539772**

9 Pneumatic resistance, long

The component acts as pneumatic resistance. Due to the small diameter and long length of the tubing, the two key features of pneumatic tubing and how they affect the flow rate and system behavior can be examined.

- Tubing outside diameter: 2 mm
- Tubing length: 12 m
- Pneumatic connection with QS-4 push-in fitting
- Quick-action mounting system Quick-Fix

Order no. **4646991**

10 Pneumatic resistance, short

The component acts as pneumatic resistance. Due to the small tubing diameter, the effects on the flow rate and system behavior can be examined.

- Tubing outside diameter: 2 mm
- Tubing length: 10 cm
- Pneumatic connection with QS-4 push-in fitting

Order no. **4809992**



Pneumatics

Control valves

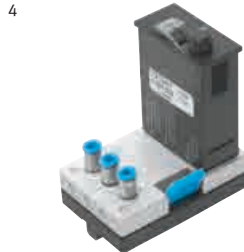
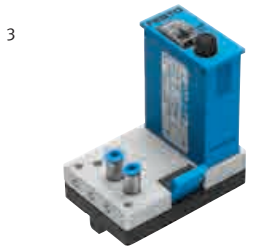

1 Dual-pressure valve (AND)

The dual-pressure valve is switched through to the output by applying compressed air to both of the inputs (AND function).

- Design: AND gate (dual-pressure valve)
- Pressure range: 100 – 1000 kPa (1 – 10 bar)
- Nominal flow rate: 1, 1/3 – 2: 550 l/min

Order no. **539770**

2 Shuttle valve (OR)

The shuttle valve is switched through to the output by applying compressed air to one of the inputs (OR function).

- Design: OR gate (shuttle valve)
- Pressure range: 100 – 1000 kPa (1 – 10 bar)
- Nominal flow rate: 1, 1/3 – 2: 500 l/min

Order no. **539771**

3 Pneumatic timer, normally closed

Pneumatic timer (time delay valve). The timer switches input pressure applied to port 1 through to port 2 after a preset time delay has expired. The time delay is infinitely adjustable between 2 and 30 sec. via an adjusting knob.

Order no. **540694**

4 Pneumatic timer, normally open

Pneumatic timer (time delay valve). In the normal position, port 1 is switched through to port 2. The pneumatic timer is started by a pneumatic signal at the control port. It is actuated at the end of a set time delay and reset via spring return to the initial position after the signal has been removed. The time delay is infinitely adjustable between 2 and 30 sec. via an adjusting knob.

Order no. **539759**

5 Pneumatic preset counter

The pneumatic preset counter counts pneumatic signals, decrementing from a preset number. When zero is reached, the counter emits a pneumatic output signal.

- Design: Mechanical counter with pneumatic drive
- Display: 5-digit, character size 4.5 mm
- Reset: Manual pushbutton or pneumatic signal
- Pressure range: 200 – 800 kPa (2 – 8 bar)
- Minimal pulse duration Drive: 10 ms
- Minimal pulse duration Reset: 180 ms
- Continuous counting frequency: 2 Hz

Order no. **152877**

6 Pressure sequence valve

The pressure of the control signal can be set by means of the pressure setting screw (infinitely variable).

- Design: Poppet valve with return spring
- Operating pressure range: 180 – 800 kPa (1.8 – 8 bar)
- Control pressure range: 100 – 800 kPa (1 – 8 bar)
- Nominal flow rate: 1 – 2: 100 l/min
- Quick action mounting system Quick-Fix

Order no. **152884**

Pneumatics

Control valves/vacuum technology

1 Back pressure valve

The back pressure valve with plunger control is actuated by the face of the cylinder cam. The supply pressure can be regulated by means of a one-way flow control valve.

- Supply pressure range: 0 – 800 kPa (0 – 8 bar)
- Closing force at 600 kPa (6 bar): 12.5 N

Order no. **152868**

2 Stepper module

- Design: Poppet valve with integrated AND and OR gates
- Nominal flow rate: P – A: 60 l/min
- Pressure range: 200 – 800 kPa (2 – 8 bar)

2 Stepper module

Comprising three TAA modules and one TAB module.

Order no. **152886**

Stepper module, expansion

The stepper controller is obtained from the series connection of four type TAA basic modules. This module comprises a memory (5/2-way double pilot valve) with display and manual override as well as an AND and OR gate.

Order no. **152885**

3/4/5 Vacuum generator

- Operating pressure: 1 – 8 bar
- Nominal diameter of laval nozzle: 0.45 mm
- QS-4 connections
- With silencer, plug-in
- Quick action mounting system Quick-Fix

3 Vacuum generator, type H

- Nominal operating pressure: 4.5 bar
- Max. suction rate with respect to atmosphere: 6.2 l/min
- Maximum vacuum: 88%

Order no. **573258**

4 Vacuum generator, type L

- Nominal operating pressure: 6 bar
- Max. suction rate with respect to atmosphere: 15.7 l/min

Order no. **573259**

5 Vacuum generator, type M

- Nominal operating pressure: 6 bar
- Max. suction rate with respect to atmosphere: 6.1 l/min
- Maximum vacuum: 86%

Order no. **548628**

1



3/4/5



2

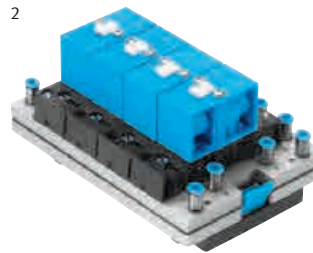

Pneumatics

Drives/actuators

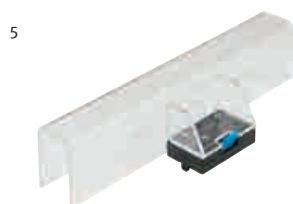
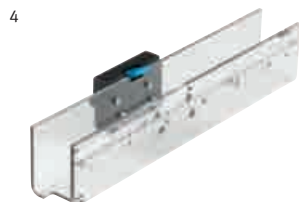

1 Single-acting cylinder

Single-acting cylinder with control cams.

- Operating pressure: Maximum 1000 kPa (10 bar)
- Stroke length: Maximum 50 mm
- Thrust at 600 kPa (6 bar): 150 N
- Spring return force minimal: 13.5 N

Order no. **152887**

2/3 Double-acting cylinder

Double-acting cylinder with control cams. End-position cushioning with two adjusting screws. A permanent magnet is mounted on the cylinder piston. Its magnetic field can trigger a proximity switch.

- Operating pressure: Maximum 1000 kPa (10 bar)
- Stroke length: Maximum 100 mm
- Thrust at 600 kPa (6 bar): 165 N
- Return thrust at 600 kPa (6 bar): 140 N

Order no. **152888**

3 Double-acting cylinder, smooth running

Order no. **4809915**

4/5 Cover for cylinder

Reduces the risk of injury. With a guide for easy positioning of limit switches and proximity sensors. Also suitable for a cylinder with mounting kit. For cylinders with more than 200 mm stroke, use two covers. For all differential and steady-speed cylinders. For differential cylinders 25/18/200 the adapter (order no. 573272) will also be needed.

- Quick-action mounting system Quick-Fix

Order no. **556290**

5 Cover for cylinder

Suitable for cylinders order no. 152887, 152888 and 549832 with weight order no. 572778, and cylinder order no. 152857 without weight. The position of the cover can be sensed, for example using electric limit switches order no. 183322 and 183345.

Order no. **572777**

6 Double-acting profile cylinder

Double-acting compact cylinder with trip cam. The cylinder piston is fitted with a permanent magnet, the magnetic field of which is used to actuate proximity sensors. There are slots on three of the sides for mounting the proximity sensors. Integrated cushioning rings absorb the residual energy in the end positions.

- Operating pressure: Maximum 1000 kPa (10 bar)
- Piston diameter: 20 mm
- Theoretical thrust at 600 kPa (6 bar): 188 N
- Theoretical return force at 600 kPa (6 bar): 141 N

Order no. **549832**

7 Weight, 2 kg, for cylinder

With plain-bearing guide and mounting material for attaching to cylinder with M8 thread.

Order no. **572778**

8 Driving/tractive load

Demonstration of a tractive or driving load. Consisting of a double-acting cylinder, a weight of 55 N and two restrictors. Mounting on the profile plate is by means of two hammer-head nuts.

- Operating medium: dried air, lubricated or unlubricated
- Operating pressure: 100 – 1000 kPa (1 – 10 bar)
- Cushioning length: 17 mm
- Theoretical force at 6 bar (return): 158.3 N
- Theoretical force at 6 bar (advance): 188.5 N
- Mode of operation: double-acting
- Impact energy in the end positions: 0.2 J

Order no. **152889**

9 Stop, 35 mm adjustment path

Facilitates adjustable end position of piston rod with (fixed) stop within stroke range of cylinder.

- Load max. N 190 (at 6 bar)
- Quick action mounting system Quick-Fix

Order no. **548630**

Pneumatics

Drives/actuators

1 Semi-rotary drive, size 16, 180°

- Semi-rotary drive with rotating plate for attaching weights (order no. 548581) in order to simulate loads.
- Freely adjustable swivel angle of 0 to 180°
 - Freely selectable setup position of 0 to 90°
 - Three adapters for attaching proximity sensors (order no. 2342009)
 - Flexible cushioning at both ends
 - Pneumatic connection with QS-4 push-in fitting
 - Operating pressure: 200 – 800 kPa (2 – 8 bar)
 - Quick action mounting system Quick-Fix

Order no. **544313**

2 Weight, 175 g

Set of two weights (2 x 175 g) for the quarter turn actuator.

Order no. **548581**

3 Fluidic muscle, size 10

With mounting accessories for adaptation to two double-acting cylinders:

Order no. **544311**

4 Optical display (red)

The pneumatically-operated, optical display is actuated if the pressure in the line is greater than 150 kPa (1.5 bar). Suitable for monitoring and display of operational status.

- Design: Reflection principle
- Display color: Red
- Pressure range: 150 – 800 kPa (1.5 – 8 bar)
- Quick action mounting system Quick-Fix

Order no. **152893**

5 Compressed air motor

The motor converts pneumatic energy into mechanical, rotational energy and can be operated both clockwise and anti-clockwise.

- Operating pressure: 300 – 600 kPa (3 – 6 bar)
- Nominal rotary speed: 975 RPM
- Flywheel
- Increments for optical sensor: 1/rev and 12/rev
- Pneumatic connection with QS-4 push-in fitting
- Quick-action mounting system Quick-Fix

Order no. **4645172**

6 Air bearing

The Air Bearing consists of a disk with an inlet duct leading to an underneath cavity. When pressurized air is applied, friction-free movement on a thin film of air is possible.

- Pneumatic connection with QS-4 push-in fitting

Order no. **4809899**

7/8/9/10/11/12/13

Suction gripper

- With suction cup holder and handle
- Connection QS-4 or QS-6

7 20 CS with vacuum security valve

- Diameter: 20 mm
- Bellows structure: 3.5 x
- Suction cup material: VMQ

Order no. **573047**

8 Suction gripper 20 SN

- Diameter: 20 mm
- Suction cup material: NBR

Order no. **573043**

9 Suction gripper 20 SS

- Diameter: 20 mm
- Suction cup material: VMQ

Order no. **573045**

10 Suction gripper 30 SN

- Diameter: 30 mm
- Suction cup material: NBR

Order no. **573044**

11 Suction gripper 30 SS

- Diameter: 30 mm
- Suction cup material: VMQ

Order no. **573046**

12 Suction gripper 4x20 ON

- Oval suction cup design, 4 x 20 mm
- Suction cup material: NBR

Order no. **573257**

13 Suction gripper, 10 mm diameter

- 360° rotatable, detenting every 15°
- Gripper diameter: 10 mm
- Breakaway force at 70% vacuum 4.5 N
- Quick action mounting system Quick-Fix

Order no. **560158**

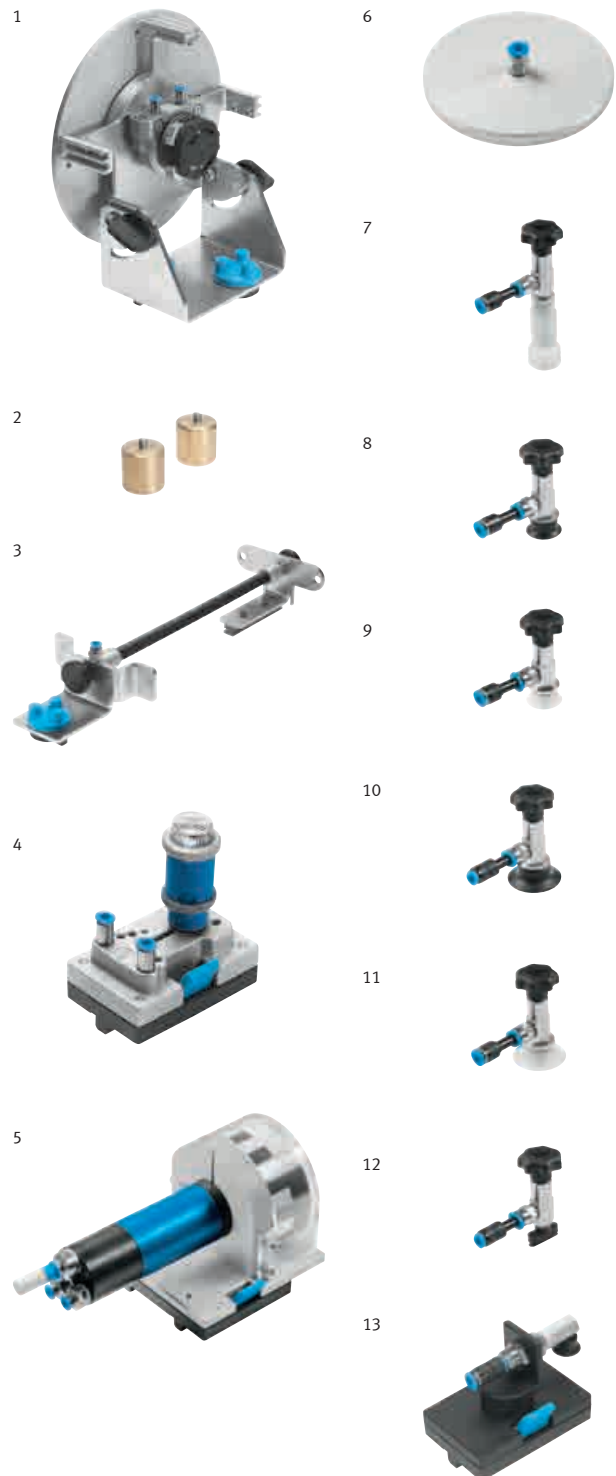

Pneumatics

Drives/actuators

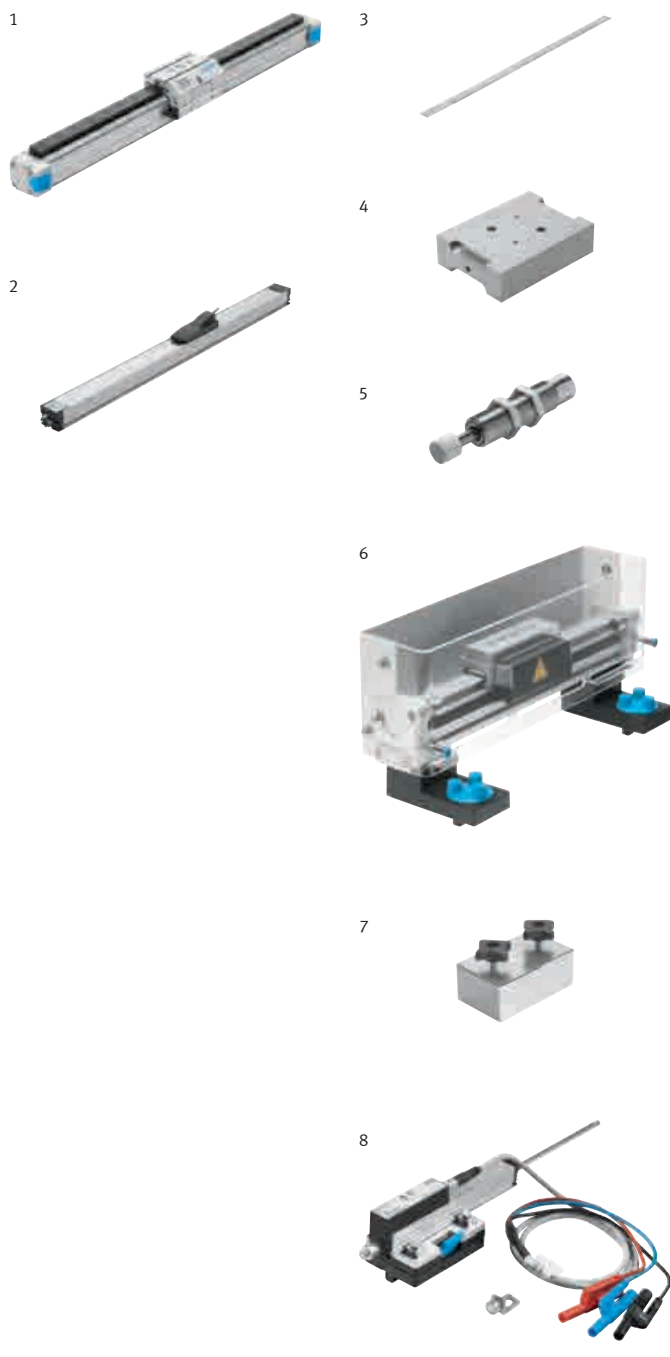

1 Linear drive, pneumatic, with guide and accessories

- Rodless linear drive with guide.
- Space-saving, rodless linear drive with recirculating ball bearing guide
 - Double-acting cylinder; compressed air produces forward and return stroke
 - The point of force delivery is protected against rotation around the longitudinal axis of the drive
 - Adjustable, end position cushioning at both end positions
 - The piston is fitted with a permanent magnet whose magnetic field can be sensed via suitable proximity switches. This permits contactless sensing of intermediate and end positions of the drive

- Cushioning type: pneumatic buffering, adjustable
- Cushioning length: 18 mm
- Protection against torsion: guide
- Stroke length: 450 mm
- Overall length: 650 mm
- Pressure range: 200 – 800 kPa (2 – 8 bar)
- Connection type: thread G 1/8"
- Effective force (theoretical) at 600 kPa (6 bar): 295 N
- Air consumption at 6 bar: 0.03 l/stroke
- Including connection and assembly material

Order no. **192501**

2 Position encoder

- (Position measuring system)
Analog displacement encoder for pneumatic linear drive unit (order no. 192501) for determining the current actual position. When ordering single units, please also order mounting accessories (order no. 178441). The connection cable (order no. 376177) is required for use in TP 111.
- Measuring stroke: 450 mm
 - Output signal at cable output of Connection cable (order no. 376177): 0 – 10 V

- Slide potentiometer without connecting rod, which delivers an output voltage proportional to the wiper setting.
- Operating voltage: 13 – 30 V
 - Eff. electrical displacement: 457 mm
 - Output voltage: 0 – 10 V
 - Adjustment speed: ≤ 10 m/s
 - Adjustment acceleration: ≤ 200 m/s²

Order no. **152628**

Mounting accessories for position encoder

Order no. **8065079**

Connecting cable for linear potentiometer

Order no. **376177**

3 Ruler

- Ruler, with millimeter scale printed on both sides, with two knurled screws. Used to measure position of the guides of the linear drive (order no. 192501).
- Total length: 580 mm
 - Scale length: 450 mm
 - 2 knurled screws

Order no. **525927**

4 Weight, 5 kg, for linear drive

- Weight for mounting on the linear drives (order no. 8028726 and order no. 167089), to be used as additional load.

Order no. **34065**

Adapter for Y-axis or weight

- Adapter for mounting the applied load on the pneumatic linear drive unit.

Order no. **167032**

5 Shock absorber

- Self-setting, hydraulic shock absorber for smooth deceleration. Suitable for a pneumatic linear drive (order no. 192501). When ordering separately, please also order shock absorber bracket (order no. 152908).
- Stroke: 12 mm
 - Impact speed: Maximum 3 m/s

Order no. **34572**

6 Linear drive, size 18, 170 mm stroke

- Stroke with plain-bearing guide, elastic cushioning rings, and safety guard

Order no. **548641**

7 Weight, 2 kg

- For linear drive (order no. 548641)

Order no. **548582**

8 Tec2Screen® measuring unit

- Displacement sensor with contactless, inductive measuring principle based on a PCB for direct, precision measurement of displacement. Integrated signal processing with teach-in function makes an absolute and proportional voltage signal available at the output.

Order no. **8030544**

Pneumatics

Hosing, distributing

1 On-off valve with filter/regulator, 5 µm

Filter regulator valve with pressure gauge, on-off valve, quick push-in connectors, and quick coupling plug, mounted on a swivel support. The filter with water separator removes dirt, pipe sinter, rust, and condensed water. The pressure regulator maintains the supply air pressure at the set operating pressure and compensates pressure fluctuations. The filter bowl has a condensate drain valve.

The on-off valve pressurizes and vents the entire control system. The 3/2-way valve is actuated by a rotary button.

- Design: Piston regulator valve with sintered filter and water trap
- Standard nominal flow rate: 1600 l/min
- Input pressure: max. 1600 kPa (16 bar)
- Working pressure: max. 1200 kPa (12 bar)
- Grade of filtration: 5 µm
- Condensate quantity: 43 cm³
- Connector: G 1/8, QS-6 for plastic tubing PUN 6 x 1

Order no. **526337**

2 Start-up valve with filter control valve

Filter control valve with Pressure gauge and Start-up valve mounted on adapter with adjustable angle. The Start-up valve pressurizes/exhausts the connected pressure zone.

- Design: sintered filter with water separator and piston regulator
- Standard flow: 120 l/min
- Pressure regulation range: 50 – 700 kPa (0,5 – 7 bar)
- Grade of filtration: 40 µm
- Fitting: G 1/8, QS-6, for Plastic tubing PUN 6 x 1

Order no. **540691**

3 Lockable on-off valve with filter regulator

Filter regulator with pressure gauge and on-off valve mounted on a swivel support. The on-off valve pressurizes and exhausts the connected pressure zone. The lockable on-off valve reliably prevents unauthorized activation.

- Design: lockable on-off valve, filter regulator with pressure gauge
- Standard nominal flow rate: 750 l/min
- Operating pressure: 100 – 1000 kPa (1 – 10 bar)
- Grade of filtration: 40 µm
- Connection: G 1/8, QS-6, for plastic tubing PUN 6 x 1

Order no. **4795290**

4 Plastic tubing

Very flexible and pressure secure.

4 x 0.75 silver 10 m **151496**

3 x 0.5 silver 5 m **197118**

6 x 1 silver 5 m **152963**

Minimum order quantity/packaging unit quantity: 50 m

4 x 0.75 silver **152584**

4 x 0.75 blue **159662**

4 x 0.75 black **159663**

4 x 0.75 red **178410**

4 x 0.75 yellow **178417**

4 x 0.75 green **178424**

5 Air pressure reservoir

The air reservoir with latching system can be mounted on a profile plate. The accumulator is equipped with pneumatic push-in fittings at both ends.

Functions:

- Generating static pressures using a one-way flow control valve
- Generating long time delays in connection with time-delay and flow control valves
- Compensation of pressure fluctuations
- Use as an accumulator if the pressure suddenly drops
- Generating a controlled system with a first-order delay (PT1)

Technical data:

- Operating medium: filtered, lubricated or unlubricated compressed air
- Pressure range: 0 – 600 kPa (0 – 16 bar)
- Connection: Both sides QSL-1/8-4 for plastic hose PUN 4 x 0.75
- Quick action mounting system Quick-Fix

5 Air pressure reservoir, 0.4 l

– Volume: 400 ml

Order no. **152912**

Air pressure reservoir, 0.1 l

– Volume: 100 ml

Order no. **573281**

6 Manifold

Manifold with eight self-closing non-return valves. A common manifold (QS-6 for plastic tubing PUN 6 x 1) allows supply of compressed air to the control via eight individual ports (QS-4 for plastic tubing PUN 4 x 0.75).

– Connector: G 1/8

Order no. **152896**

1



2



3



4



5



6



Pneumatics

Sensors/Measuring technology



1 Pressure gauge
 The pressure gauge shows the pressure in pneumatic control circuits.

- Design: Bourdon tube pressure gauge
- Display range: 0 – 1000 kPa (0 – 10 bar)
- Quality class: 1.6
- Quick action mounting system Quick-Fix

Order no. **152865**



2 Vacuum gauge

- Adjustable red/green range
- Indicating range/operating pressure: -1 – 0 bar
- Quick action mounting system Quick-Fix

Order no. **573042**



3 Pressure sensor with display
 Piezo-resistive relative pressure sensor with LCD display, freely programmable switching function, adjustable hysteresis, and analog output for direct measured data acquisition.

- 360° rotatable, detenting every 15°
- Power supply: 15 – 30 V DC
- Switching output: PNP
- Analog output: 0 – 10 V DC
- Pneumatic connection via QS-4 push-in fitting
- Pressure measuring range: 0 – 1000 kPa (0 – 10 bar)
- Quick action mounting system Quick-Fix



Symbols according to IEC standard
 Order no. **572745**

Symbols according to NEMA-Standard
 Order no. **8062966**



4 Proximity sensor, electronic, with cylinder mounting
 Magneto-resistive proximity sensor, magnetically operated

- Connection via 4 mm safety sockets
- Switching output N/O contact (PNP) with switching status indication
- Overload and short-circuit proof, with reverse polarity protection
- Operating voltage: 5 – 30 V DC
- Output current: max. 100 mA
- Switching time (on/off) max. 1 ms
- Mounting system for cylinder diameter 20 mm, 2x T-slot for simultaneous mounting of one pneumatic and one electronic proximity sensor

Order no. **2344752**

5 Proximity sensor, pneumatic, with cylinder attachment
 3/2-way valve, normally closed, magnetically actuated

- Precision quick plug connector for plastic tubing PUN-4 x 0.75 or for tubing types with standard inner or outer diameter
- Pressure range: 200 – 800 kPa (2 – 8 bar)
- Switching time (on/off) 22 ms/52 ms
- Visual switching status indication
- Mounting system for cylinder diameter 20 mm, 2x T-slot for simultaneous mounting of one pneumatic and one electronic proximity sensor

Order no. **2764815**



Cylinder mounting for pneumatic and electronic cylinder switches
 Mounting system for cylinder diameter 20 mm, 2x T-slot 8 for simultaneous mounting of one pneumatic and one electronic cylinder switch.

Order no. **2341763**

6 Pressure sensor, analog
 The analog pressure sensor is a piezo-resistive relative pressure transducer with integrated amplifier and built-in temperature compensation in an aluminum housing.

- Measured variable: relative pressure
- Measurement method: piezo-resistive pressure sensor
- Pressure measuring range: 0 – 1000 kPa (0 – 10 bar)
- Max. pressure: 1400 kPa (14 bar)
- Supply voltage: 12 – 30 V DC
- Analog output: 0 – 10 V, 0 – 20 mA
- Total error: ±1% of end value
- Operating medium: filtered compressed air, grade of filtration 40 µm
- Electrical connection: 4 mm safety sockets
- Maximum frequency: 100 Hz
- Electrical protection: short-circuit proof, protected against reverse polarity
- Quick action mounting system Quick-Fix

The sensor will also supply a signal at pressures of < 0 bar. Linearity and proportionality cannot be guaranteed in this case.

Order no. **167094**

Pneumatics

Sensors/Measuring technology

1 Flow sensor, 0.5 – 50 l/min, analog

- Rotatable, 90° detenting
- M12x1 connector, 5-pin
- Cable with M12 x 1 socket and 4 mm safety plug
- Switching output: 2 x PNP
- Analog output: 0 – 10 V
- Operating voltage range: 12 – 30 V DC
- Switching element function, selectable
- Switching function freely programmable
- Flow measurement range: 0.5 – 50 l/min
- Quick action mounting system Quick-Fix

Order no. **8036235**

2 Force sensor

Force sensor for piston force measurement in the TP 210. Mounting is performed on a slotted profile plate using two T-head nuts. Electrical connection is by means of 4 mm safety plugs.

- Measuring range: 0 – 1 kN
- Supply voltage: 24 V DC
- Output voltage: 0 – 10 V

Order no. **539780**

3 Flow indicator with float, pneumatic

- Mechanical flow indicator according to the float principle for measuring flow in standard liters, i.e., against atmospheric pressure.
- Operating pressure: 100 – 800 kPa (1 – 8 bar)
 - Measuring range: 30 – 200 SLPM, 1 – 7 SCFM
 - Pneumatic connection with QS-4 push-in fitting
 - Vertical positioning of the indicator can be adjusted without tools via a swivel mechanism
 - Quick-action mounting system Quick-Fix

Order no. **4741762**

4 Spring load for cylinders, pneumatic

The spring load is installed on the double-acting cylinder (order no. 152888). In the forward stroke, the cylinder compresses the spring. The stroke and force of the cylinder can be read off on the scale.

- Measuring range: stroke 0 – 50 mm/0 – 2 in force 0 – 230 N/0 – 50 lbf
- Quick-action mounting system Quick-Fix

Order no. **4646789**

1



2



3



4



Pneumatics

Accessories and optional components



1 T-connector (Quick Star quick push-in fitting)
 Precision barbed T connector for quickly establishing branches with low amounts of power, for plastic tubing, 4 mm outside diameter (calibrated).
 – Simply “plug and work”
 – Flexible assembly – all fittings can be rotated 360° around the threaded part
 – Absolutely safe and secure – with an NBR plastic seal
 – Multiple use – thread with self-sealing PTFE coating

Minimum order quantity/packaging unit quantity: 10 pieces

- Type 1 Straight fitting M5 (QSM-M5-4)
 Order no. **153304**
- Type 2 Straight fitting, G1/8 (QS-G1/8-4)
 Order no. **186095**
- Type 3 Elbow connector, rotatable, M5 (QSML-M5-4)
 Order no. **153333**
- Type 4 Elbow connector, rotatable, G1/8 (QSL-G1/8-4)
 Order no. **186116**
- Type 5 Elbow connector, 4H (QSL-4H)
 Order no. **153056**
- Type 6 Straight fitting, self-closing, M5 (QSK-M5-4)
 Order no. **153291**
- Type 7 Straight fitting, self-closing, G1/8 (QSK-G1/8-4)
 Order no. **186294**
- Type 8 T-connector (QST-4)
 Order no. **153128**
- Type 9 T-connector (QST-6)
 Order no. **153129**
- Type 10 Plug-in bulkhead connector (QSMS-4)
 Order no. **153376**
- Type 11 Blanking plugs (QSC-4H)
 Order no. **153267**
- Type 12 Push-in sleeve (QSH-4)
 Order no. **153251**
- Type 13 Push-in connector (QSM-6H-4)
 Order no. **153329**

2 Pipe and tubing cutter
 For plastic and Perbunan tubing with and without fabric reinforcement with outside diameters up to 20 mm. Ensures a vertical, burr-free cut through positive locking of tubing in the cutter. It also has a safety clip to prevent unauthorized opening. Supplied with two spare blades.
 Order no. **7658**

3 Tubing cutter
 For optimal cutting of plastic tubing.
 Order no. **255851**

Releasing tool
 For releasing all QS connectors for tubing outside diameters of 3 to 10 mm.
 Order no. **158419**

Silencer and sealing rings
 Minimum order quantity/packaging unit quantity: 10 pieces

- Sealing ring OL-M5
 Order no. **34634**
- Silencer U-1/8
 Order no. **2307**
- Sealing ring OL-1/8
 Order no. **33840**

4 Compressor
 Sound pressure of only 41 dBA, so well-suited for use in classrooms. Supplies up to four stations. Complete with pressure regulator, water separator, 5 m tubing 6 mm in diameter, 3 T-distributors.
 – Pressure: max. 400 kPa (4 bar)
 – Suction capacity: 14 l/min
 – Reservoir capacity: 2.5 l
 – Dimensions: 310 x 150 x 370 mm

Version: 230 V/50 Hz
 With IEC power cable to CEE 7/VII suitable for: DE, FR, NO, SE, FI, PT, ES, AT, NL, BE, GR, TR, IT, DK, IR, ID
 Order no. **548707**
 Version: 120 V/60 Hz
 With IEC power cable to NEMA 5-15 suitable for: US, CA, Central America, BR, CO, YU, EC, KR, TW, TH, PH, JP
 Order no. **556275**

5 Compressor
 Oil-lubricated, extremely quiet (45 dB (A)) compressor. Ideally suited for use in classrooms. With pressure regulator and water separator.
 – Pressure: 800 kPa (8 bar) P_{max}
 – Performance: 50 l/min
 – Reservoir capacity: 24 l
 – Compressed air outlet: ¼” or KD4
 – Noise level: 45 dB (A)/1 m
 – Duty cycle: max. 50 %
 – Pressure regulator valve with gauge

Version: 230 V/50 Hz
 With IEC power socket and IEC power cable to CEE 7/VII suitable for: DE, FR, NO, SE, FI, PT, ES, AT, NL, BE, GR, TR, IT, DK, IR, ID.
230V 91030
 Version: 120 V/60 Hz
 With IEC power socket and plug to NEMA 5-15 suitable for: US, CA, Central America, BR, CO, EC, KR, TW, TH, PH, JP.
110V 565440

Compressor accessories
 Consisting of:
 – Coupling socket (KD3-CK-4 and KD4-1/4-A)
 – Coupling plug (KS4-CK-4)
 – Tubing (6 x 1 silver 2.5 m)
 Order no. **102725**

Pneumatics

Additional components

1/2 Universal adapter

The adapter enables Festo pneumatic components and those of other manufacturers to be mounted on the aluminum profile plate. You can continue to use your existing components and still benefit from the advantages of using the aluminum profile plate system and the patented Quick-Fix mounting system from Festo Didactic.

- Plug-in, clamp, ready – no force required
- No worn-out sockets
- Exact positioning of components
- Working in a third dimension
- Universally suitable for Festo and third-party components
- Quick action mounting system Quick-Fix

You can mount the components onto the adapter yourself. It is quick, easy, and reliable with slotted screws (included in scope of delivery). Available in two sizes. The adapters are thus universally usable for an enormous number of components with a through hole – regardless of the manufacturer.

Not suitable for mounting of hydraulic components.

3 75 x 50 x 30 mm	195224
4 75 x 100 x 30 mm	195225

3 Quick-Fix screw adapter

The Quick-Fix screw adapter makes it possible to attach components to a slotted profile plate.

Order no. **549806**

4 Quick-Fix clamping adapter

The Quick-Fix clamping adapter makes it possible to attach small components on a slotted profile plate.

Order no. **8026327**

5 Multiple tubing holder strip set

Multiple tubing holder strip for aluminum profile plate. Easily attaches to the aluminum slotted profile plate; a neat solution for up to 6 tubes/cables per strip. Set of 10.

Order no. **544317**

6 DIN rail set

Two 300 mm long DIN rails, matching relay socket and terminal set, with mountings for adapter fitting to aluminum slotted profile plate.

Order no. **548637**

7 Cable duct set

1x 150 mm, 3x 265 mm and 1x 500 mm cable ducts with mountings for adapter fitting to aluminum slotted profile plate.

Order no. **548638**

8 Accessory box

The accessory box contains pneumatic connectors and tubing accessories as well as a tubing cutter and releasing tool for pneumatic connectors.

Order no. **167020**

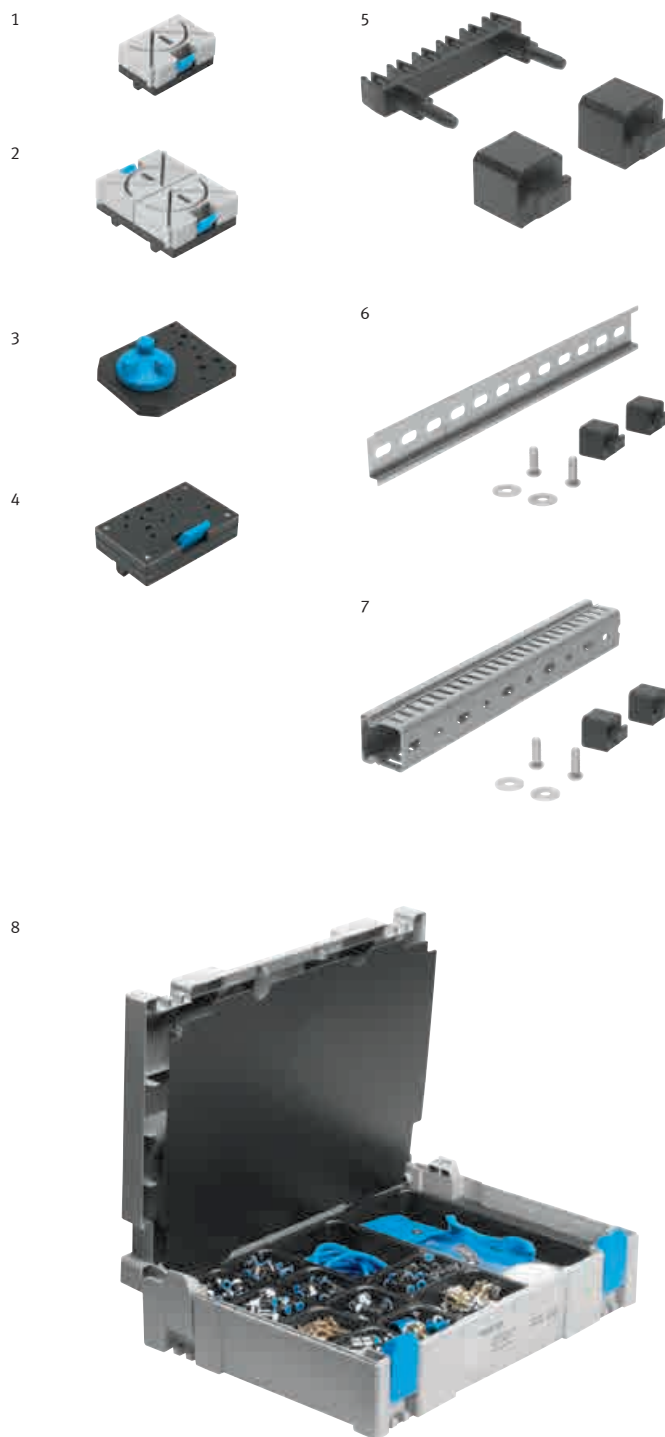

Hydraulics

Directional control valves

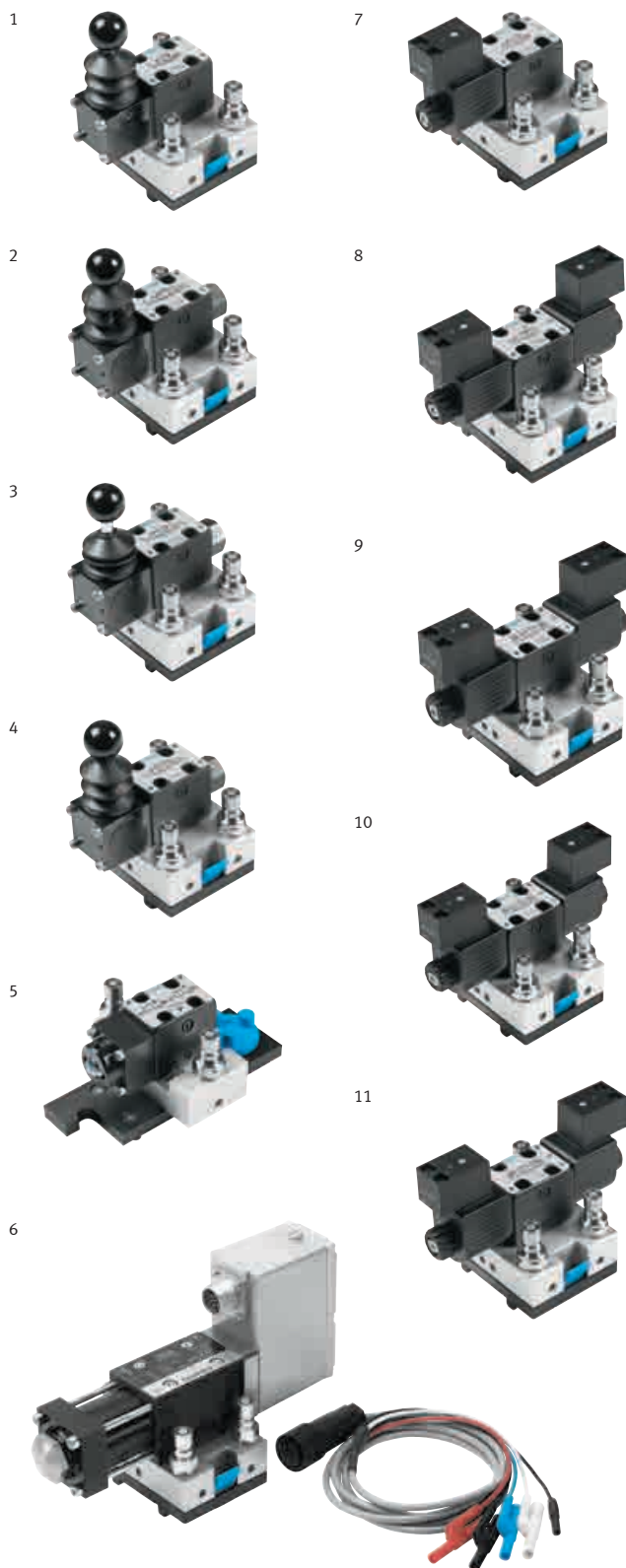

1/2/3/4 Hand lever valves

- Actuation: manual
- Operating pressure: 6 MPa (60 bar)
- Maximum permissible pressure: 12 MPa (120 bar)
- Valve port pattern, hydraulic ISO/DIN 4401 size O2
- Low-leakage, self-sealing coupling nipples
- Quick action mounting system Quick-Fix

1 4/2-way hand lever valve, spring return

Order no. **544342**

2 4/3-way hand lever valve, closed mid-position, detenting

Order no. **544343**

3 4/3-way hand lever valve, relieving mid-position (AB → T), detenting

Order no. **544344**

4 4/3-way hand lever valve, bypass mid-position (P → T), detenting

Order no. **544345**

4/3-way hand lever valve, H-center position, detenting (PTAB)

Order no. **8065281**

5 2/2-way stem actuated valve, convertible

- Manual actuation, by means of the guide bar of a cylinder with mounting kit, spring return
- Normal position P→A, can be converted
- Operating pressure: 6 MPa (60 bar)
- Maximum permissible pressure: 12 MPa (120 bar)
- Valve port pattern, hydraulic ISO/DIN 4401 size O2
- Low-leakage, self-sealing coupling nipples
- Quick action mounting system Quick-Fix

Order no. **544353**

6 4/3-way regulating valve

- Directly actuated servo valve with electrical, closed-loop position control of the control piston.
- Zero overlap and linear characteristic curve (flow rate to control piston position)
 - Mid-position closed, de-energized
 - Actuation: permanent magnet, adjustment by linear motor

- Integrated position, driver, and amplifier electronics
- Operating pressure: 6 MPa (60 bar)
- Maximum permissible pressure: 12 MPa (120 bar) on T 5 MPa (50 bar)
- Valve port pattern, hydraulic ISO/DIN 4401 size O3
- Low-leakage, self-sealing coupling nipples
- 24 V DC power
- Current consumption: Maximum 1.2 A
- Setpoint signal ±10 V DC
- Electrical connection: cable with 4 mm safety socket
- Quick action mounting system Quick-Fix

Order no. **567269**

7/8/9/10/11 Solenoid valves

- Actuation: switching solenoid
- Operating pressure: 6 MPa (60 bar)
- Maximum permissible pressure: 12 MPa (120 bar)
- Valve port pattern, hydraulic ISO/DIN 4401 size O2
- Low-leakage, self-sealing coupling nipples
- 24 V DC power
- 6.5 W output
- Electrical connection: 4 mm safety socket
- Quick action mounting system Quick-Fix

7 4/2-way solenoid valve, spring return

Order no. **544346**

8 4/2-way double solenoid valve, detenting

Order no. **544352**

9 4/3-way solenoid valve, closed mid-position

Order no. **544347**

10 4/3-way solenoid valve, relieving mid-position (AB → T)

Order no. **544348**

11 4/3-way solenoid valve, bypass mid-position (P → T)

Order no. **544349**

Hydraulics

Directional control valves

1 4/3-way proportional valve

This valve is used for controlling both the direction and rate of hydraulic volumetric flow.

- Mid-position closed, de-energized
- Actuation: proportional solenoid
- Operating pressure: 6 MPa (60 bar)
- Maximum permissible pressure: 12 MPa (120 bar)
- Valve port pattern, hydraulic ISO/DIN 4401 size 02
- Low-leakage, self-sealing coupling nipples
- 24 V DC power
- Nominal current 800 mA
- Electrical connection: 4 mm safety socket
- Quick action mounting system Quick-Fix

Order no. **544350**

2 Pressure balance (proportional flow control valve)

The pressure balance expands the 4/3-way proportional valve (order no. 544350) to form a proportional flow control valve. This vertical stacking valve is installed between the sub-base and the proportional directional control valve.

- Operating pressure: 6 MPa (60 bar)
- Maximum permissible pressure: 12 MPa (120 bar)
- Valve port pattern, hydraulic ISO/DIN 4401 size 02

Order no. **159351**

3 6/3-way proportional hand lever valve

This valve is used for controlling both the direction and rate of hydraulic volumetric flow rates. Serial, parallel, and tandem circuits can be created by linking several valves.

- Mid-position, spring centred, P1→T1, P2T2AB blocked
- Actuation: manual
- Operating pressure: 6 MPa (60 bar)
- Maximum permissible pressure: 12 MPa (120 bar), T2 for brief periods only 6 MPa (60 bar)
- Low-leakage, self-sealing coupling nipples
- Quick action mounting system Quick-Fix

Order no. **572141**

4 Mobile valve block, Load sensing

Two proportional directional control valves with supply pressure balance for load sensing controls (adaptation of pressure and volumetric flow). Suitable for pilot control device, 2x2-channel (order no. 572147).

- Mid-position closed, spring-centered (“closed center”)
- Actuation: hydraulic and manual (hand lever)
- Operating pressure: 6 MPa (60 bar)
- Pilot pressure up to 3.5 MPa (35 bar)
- Maximum permissible pressure: 12 MPa (120 bar)
- Low-leakage, self-sealing coupling nipples
- Open connection fitting for pressureless return (T)
- Quick action mounting system Quick-Fix

Order no. **572144**

5 Steering unit (Orbitrol)

This rotary slide valve is used for hydrostatic steering. When the steering wheel is turned, the steering unit dispenses a quantity of oil to the right or left which is proportional to the turning of the steering wheel. The excess volumetric flow is diverted through E and can be supplied to another consumer (“power beyond”).

- No load feedback (non-reaction)
- Open center (for constant-displacement pump)
- Actuation: manual (steering wheel)
- Operating pressure: 6 MPa (60 bar)
- Maximum permissible pressure: 12 MPa (120 bar)
- Low-leakage, self-sealing coupling nipples
- Open connecting plug for pressureless return (T)
- Quick action mounting system Quick-Fix

Order no. **572146**

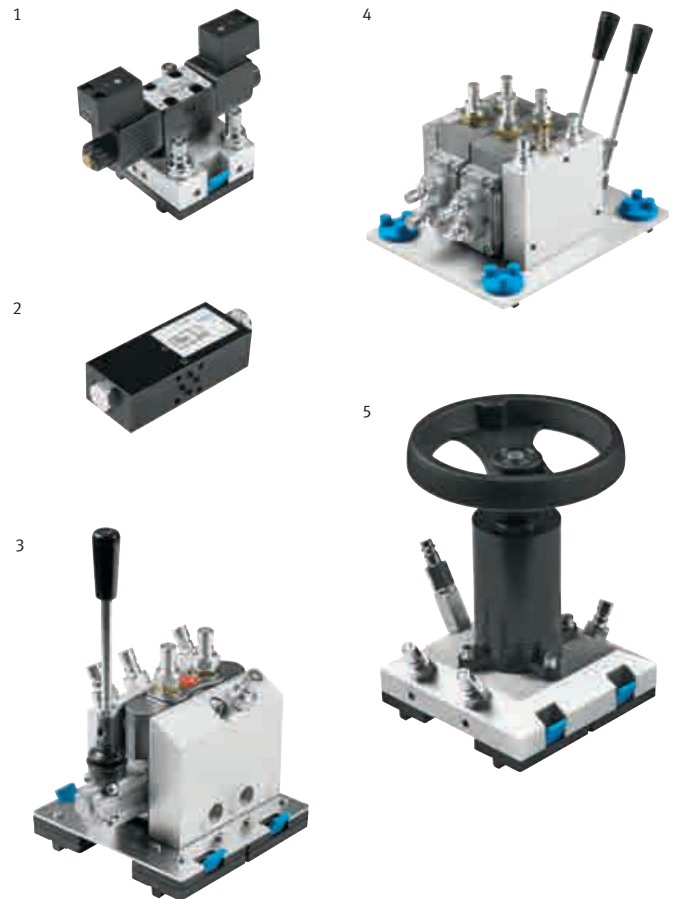

Hydraulics

Pressure valves



1 Pressure relief valve

The valve limits the pressure at port P relative to the pressure at T to the set value.

- Adjustment: manual
- Includes non-return valve
- Operating pressure 6 MPa (60 bar)
- Maximum permissible pressure: 12 MPa (120 bar)



2 Pressure relief valve, compensated

The valve limits the pressure at port P relative to the pressure at T to the set value. Pressure on T has no effect on this value because the spring chamber of the pressure relief is compensated.

- Adjustment: manual
- Includes non-return valve
- Operating pressure 6 MPa (60 bar)
- Maximum permissible pressure: 12 MPa (120 bar)



3 Pressure relief valve, piloted

The valve is capable of limiting the pressure of larger volumetric flow rates than would be possible with a directly actuated valve. The valve limits pressure from port P to port T in accordance with the spring in the primary stage and pilot pressure at X.

- Adjustment: manual
- Hydraulically piloted
- Pilot pressure accessible via port X
- Separate tank port Y for the pilot stage
- Operating pressure: 6 MPa (60 bar)
- Maximum permissible pressure: 12 MPa (120 bar)
- Low-leakage, self-sealing coupling nipples
- Quick action mounting system Quick-Fix

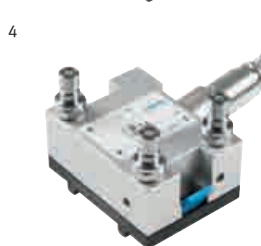

Order no. **544335**



4 3-way pressure reducing valve

The valve keeps the pressure set at port A constant, compensating for fluctuations in supply pressures and consumer loads. If the pressure at A rises above the set value, a connection opens from A to T.

- Adjustment: manual
- Operating pressure: 6 MPa (60 bar)
- Maximum permissible pressure: 12 MPa (120 bar)
- Low-leakage, self-sealing coupling nipples
- Quick action mounting system Quick-Fix



5 Pressure sequence valve

The valve connects P with T if the pressure at X is larger than the sum of the spring force and the pressure in port T.

- Adjustment: manual
- Operating pressure 6 MPa (60 bar)
- Maximum permissible pressure: 12 MPa (120 bar)
- Low-leakage, self-sealing coupling nipples
- Quick action mounting system Quick-Fix



Order no. **544337**

6 Proportional pressure relief valve

The valve is used for pressure limitation. The limit pressure is adjusted with the proportional solenoid.

- Actuation: proportional solenoid
- Operating pressure 6 MPa (60 bar)
- Maximum permissible pressure: 12 MPa (120 bar)
- Valve port pattern, hydraulic ISO/DIN 4401 size O2
- Low-leakage, self-sealing coupling nipples
- 24 V DC power
- Nominal current 800 mA
- Electrical connection: 4 mm safety socket
- Quick action mounting system Quick-Fix

Order no. **544341**

7 Counterbalance valve

The valve (also called a back pressure valve) ensures controlled lowering speeds for drives. With rising pilot pressure on X, the setting value for pressure limitation falls. The pressure relief valve is bypassed by a non-return valve from T to P.

- Adjustment: manual (with tool)
- Surface area ratio of X to P is 1:3
- Includes non-return valve
- Operating pressure 6 MPa (60 bar)
- Maximum permissible pressure: 12 MPa (120 bar)
- Low-leakage, self-sealing coupling nipples
- Quick action mounting system Quick-Fix

Order no. **572149**

Hydraulics

Pressure valves

1 Pilot valves (Joystick), 2x2-channel

Each channel has two pressure regulators which control the pressure from P to A or B. A and B are pressureless in the spring-centered neutral position. The hydraulic joysticks are used for functions such as remote or pilot control of the load sensing mobile block.

- Adjustment: manual (2x joystick)
- Operating pressure: 3.5 MPa (35 bar)
- Maximum permissible pressure: 3.5 MPa (35 bar)
- Low-leakage, self-sealing coupling nipples
- Open connection fitting for pressureless return (T)
- Quick action mounting system Quick-Fix

Order no. **572147**

2 Pressure compensator for Open Center Load Sensing

The valve is required for load sensing applications with a fixed displacement pump (open center).

- Adjustment: hydraulic
- Differential pressure: 0.055 MPa (5.5 bar)
- Operating pressure: 6 MPa (60 bar)
- Maximum permissible pressure: 12 MPa (120 bar)
- Low-leakage, self-sealing coupling nipples
- Quick action mounting system Quick-Fix

Order no. **572123**

3 Pressure compensator, upstream (pre)

This pressure compensator ensures a volumetric flow rate regardless of the load pressure.

- Adjustment: hydraulic
- Differential pressure: 0.055 MPa (5.5 bar)
- Operating pressure 6 MPa (60 bar)
- Maximum permissible pressure: 12 MPa (120 bar)
- Low-leakage, self-sealing coupling nipples
- Quick action mounting system Quick-Fix

Order no. **573023**

4 Pressure compensator, downstream (post)

The pressure compensator ensures a volumetric flow rate regardless of the load pressure. If the total volumetric flow rate demanded by all consumers together is more than that which can be supplied by the pump, the individual volumetric flow rates are reduced proportionally. The valve is used in load sensing applications with an LS variable displacement pump (closed center).

- Adjustment: hydraulic
- Differential pressure: 35 kPa (0.35 bar)
- Operating pressure: 6 MPa (60 bar)
- Maximum permissible pressure: 12 MPa (120 bar)
- Low-leakage, self-sealing coupling nipples
- Quick action mounting system Quick-Fix

Order no. **572741**

5 Flush valve with pressure relief valve

The valve is used for feeding out oil in a closed hydraulic circuit.

- Adjustment: hydraulic, with fixed setting on pressure relief valve
- Operating pressure: 6 MPa (60 bar)
- Maximum permissible pressure: 12 MPa (120 bar)
- Low-leakage, self-sealing coupling nipples
- Quick action mounting system Quick-Fix

Order no. **572126**

6 Shock and anti-cavitation valve

The valve manifold has two pressure relief valves (shock valves) to dissipate pressure peaks away to T and two replenishing valves to ensure supply to the consumer line even in the event of low pressure, e.g., during load changes.

- Adjustment: manual
- Operating pressure: 6 MPa (60 bar)
- Maximum permissible pressure: 12 MPa (120 bar)
- Low-leakage, self-sealing coupling nipples
- Quick action mounting system Quick-Fix

Order no. **572148**

1



2



3



4



5



6

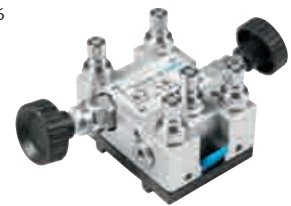

Hydraulics

Power/Lock Valves



1 Flow control valve

The valve is used to influence the volumetric flow rate through an adjustable throttle point, in both directions.

- Actuation: manual
- Operating pressure: 6 MPa (60 bar)
- Maximum permissible pressure: 12 MPa (120 bar)
- Low-leakage, self-sealing coupling nipples/quick coupling socket

Order no. **152842**



2 One-way flow control valve

The valve is used to influence the volumetric flow rate through an adjustable throttle point, in one direction. In the opposite direction, the throttle is bypassed using the non-return valve.

- Actuation: manual
- Integrated non-return valve
- Operating pressure: 6 MPa (60 bar)
- Maximum permissible pressure: 12 MPa (120 bar)
- Low-leakage, self-sealing coupling nipples/quick coupling socket

Order no. **152843**



3 Non-return valve

The valve is closed by a locking cone which is pressed against the seat by a spring. When the opening pressure on the seat side is exceeded, the valve opens and fluid can flow through it. When the pressure on the spring side is greater, the valve remains closed.

- Actuation: hydraulic
- Tube length 1000 mm
- Operating pressure: 6 MPa (60 bar)
- Maximum permissible pressure: 12 MPa (120 bar)
- Low-leakage, self-sealing quick coupling sockets

0.05 MPa opening pressure

Order no. **548617**

0.6 MPa opening pressure

Order no. **548618**



4 Shut-off valve

The valve can be closed by turning the lever. This presses a ball onto the seal on the non-pressurized side, sealing off the flow without any leakage.

- Actuation: manual
- Operating pressure: 6 MPa (60 bar)
- Maximum permissible pressure: 12 MPa (120 bar)
- Low-leakage, self-sealing coupling nipples/quick coupling socket

Order no. **152844**



5 Non-return valve, delockable

The valve is closed by a locking cone which is pressed against the seat by a spring. The locking cone does not open until X is activated. When the opening pressure on the seat side is exceeded, the valve opens and fluid can flow through it.

- Actuation: hydraulic
- Operating pressure: 6 MPa (60 bar)
- Maximum permissible pressure: 12 MPa (120 bar)
- Low-leakage, self-sealing coupling nipples
- Quick action mounting system Quick-Fix

Order no. **544339**



6 Double non-return valve, delockable

The two non-return valves are each unlocked from the opposite side.

- Surface area ratio of opening piston to non-return valve 3.3:1
- Operating pressure: 6 MPa (60 bar)
- Maximum permissible pressure: 12 MPa (120 bar)
- Low-leakage, self-sealing coupling nipples
- Quick action mounting system Quick-Fix

Order no. **572151**

Hydraulics

Power/Lock Valves

1 2-way flow control valve

The valve ensures a constant volumetric flow rate in the flow direction from A to B, regardless of the load pressure on B. The oil can flow from B to A via the non-return valve which opens.

- Actuation: manual
- Differential pressure of the pressure balance 0.55 MPa (5.5 bar)
- Operating pressure: 6 MPa (60 bar)
- Maximum permissible pressure: 12 MPa (120 bar)
- Low-leakage, self-sealing coupling nipples
- Quick action mounting system Quick-Fix

Order no. **544338**

2 3-way flow control valve

The valve ensures a constant volumetric flow rate in the flow direction from P to A, regardless of the load pressure on A. The excess volumetric flow is diverted through B and can be supplied to another consumer.

- Actuation: manual
- Differential pressure of the pressure balance 0.55 MPa (5.5 bar)
- Operating pressure: 6 MPa (60 bar)
- Maximum permissible pressure: 12 MPa (120 bar)
- Low-leakage, self-sealing coupling nipples
- Quick action mounting system Quick-Fix

Order no. **572150**

3 Flow dividing valve

The valve divides the volumetric flow rate from P between A and B in a 50:50 ratio, regardless of load.

- Actuation: hydraulic
- Minimum volumetric flow rate 0.5 l/min
- Operating pressure: 6 MPa (60 bar)
- Maximum permissible pressure: 12 MPa (120 bar)
- Valve port pattern, hydraulic ISO/DIN 4401 size 02
- Low-leakage, self-sealing coupling nipples
- Quick action mounting system Quick-Fix

Order no. **544340**

4 Shuttle valve

The flow to the outlet of the shuttle valve is opened by pressurization at one of the two inlets (OR function). If pressure is applied at both inlets, the flow is opened between the outlet and the inlet with the higher pressure.

- Actuation: hydraulic
- Operating pressure: 6 MPa (60 bar)
- Maximum permissible pressure: 12 MPa (120 bar)
- Low-leakage, self-sealing coupling nipples
- Quick action mounting system Quick-Fix

Order no. **572122**

5 Priority valve LS, dynamic

The preferential flow direction supplied by the valve is from P to CF and independent of the load pressure on CF. The excess volumetric flow is diverted through EF and can be supplied to another consumer.

- Actuation: hydraulic
- Differential pressure of the pressure balance 1.03 MPa (10.3 bar)
- Operating pressure: 6 MPa (60 bar)
- Maximum permissible pressure: 12 MPa (120 bar)
- Low-leakage, self-sealing coupling nipples
- Quick action mounting system Quick-Fix

Order no. **573022**

1



4



2



5



3



Hydraulics

Drives

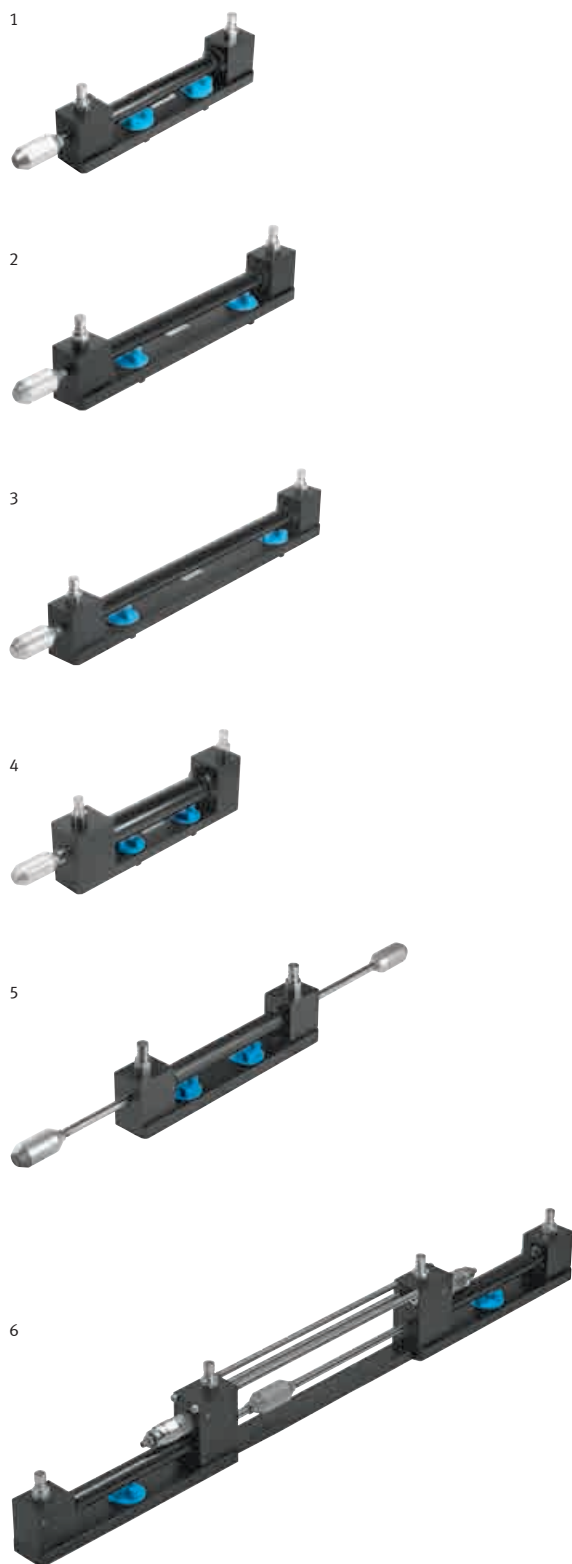

1/2/3/4 Differential cylinder

- Piston/Rod/Stroke
- Operating pressure: 6 MPa (60 bar)
- Maximum permissible pressure: 12 MPa (120 bar)
- Double-acting
- Low-leakage, self-sealing coupling nipples
- Quick action mounting system Quick-Fix

1 16/10/200 with cover

- Surface area ratio 1 : 1.6

Order no. **572746**

2 16/10/300 with cover

- Surface area ratio 1 : 1.6

Order no. **572748**

3 16/10/400 with cover

- Surface area ratio 1 : 1.6

Order no. **572749**

4 25/18/200 with cover

- Surface area ratio 1 : 2

Order no. **572747**

5 Steady-speed cylinder with covers

- Operating pressure: 6 MPa (60 bar)
- Maximum permissible pressure: 12 MPa (120 bar)
- Double-acting
- Low-leakage, self-sealing coupling nipples
- Quick action mounting system Quick-Fix
- Piston Ø: 16 mm
- Piston rod Ø: 2 x 10 mm
- Stroke: 200 mm
- Surface area ratio 1 : 1

Order no. **572750**

6 Loading unit/cylinder load simulator

With this combination, a hydraulic counteracting force can be applied to a differential or steady-speed cylinder, allowing a wide range of load situations to be set up and investigated. Available options include differential against differential (2 x 1 : 1.6), small steady-speed against large steady-speed, or large steady-speed against small steady-speed cylinder.

- Operating pressure: 6 MPa (60 bar)
- Maximum permissible pressure: 12 MPa (120 bar)
- Integrated safety valve
- Double-acting (2 x)
- Low-leakage, self-sealing coupling nipples
- Quick action mounting system Quick-Fix
- Piston Ø: 2 x 16 mm
- Piston rod Ø: 10 mm
- Stroke: 200 mm
- Surface area ratio 1 : 1 or 1 : 1.6

Order no. **572145**

Hydraulics

Drives

1 Pulling/pushing load, rotatable

Weight-loaded hydraulic cylinder with active direction rotatable without tools. The load is guided and cushioned in the end positions.

Electronic proximity sensors (order no. 2342009) can be used as an option. For mounting on a Learnline profile column or on a vertical profile plate in Learnline Mobile:

- Dimensions 665 mm x 190 mm x 157 mm
- Swivel radius 340 mm
- Weight 19 kg, of which 10 kg load
- Operating pressure: 6 MPa (60 bar)
- Maximum permissible pressure: 12 MPa (120 bar)
- Double-acting
- Low-leakage, self-sealing coupling nipples
- Piston \varnothing : 16 mm
- Piston rod \varnothing : 10 mm
- Stroke: 200 mm
- Surface area ratio 1 : 1.6
- Pressure buildup through load on piston side 0.48 MPa (4.8 bar)
- Pressure buildup through load on piston rod side: 0.8 MPa (8 bar)

Order no. **3137005**

2 Cover for cylinder

Reduces the risk of injury. With a guide for easy positioning of limit switches and proximity sensors. Also suitable for a cylinder with mounting kit. For cylinders with more than 200 mm stroke, use two covers. For all differential and steady-speed cylinders. For differential cylinders 25/18/200 the adapter (order no. 573272) will also be needed.

- Quick-action mounting system Quick-Fix

Order no. **556290**

3 Mounting kit for cylinders

Fitting a mounting kit on a cylinder makes the following possible:

- Actuation of the stem actuated valve by the guide bar
- Actuation of proximity sensors (order no. 2342009) by the permanent magnet of the guide bar
- Use of a displacement encoder

For cylinders 572746, 572750, 572145

Order no. **544371**

For cylinders 572748

Order no. **544372**

For cylinders 572747

Order no. **544373**

4 Spring load for cylinders, hydraulic

The spring load can be installed on the differential cylinder 16/10/200 without the need for tools. In the forward stroke, the cylinder compresses the spring. The stroke and force of the cylinder can be read off on the scale. For demonstrating the relationship between pressure and force for the topic of "holding load." Can be used as a piston spring accumulator.

- Measuring range:

Stroke 0 – 78 mm/0 – 3.1 in and force 0 – 1200 N/0 – 270 lbf

- Quick-action mounting system Quick-Fix

Order no. **4914138**

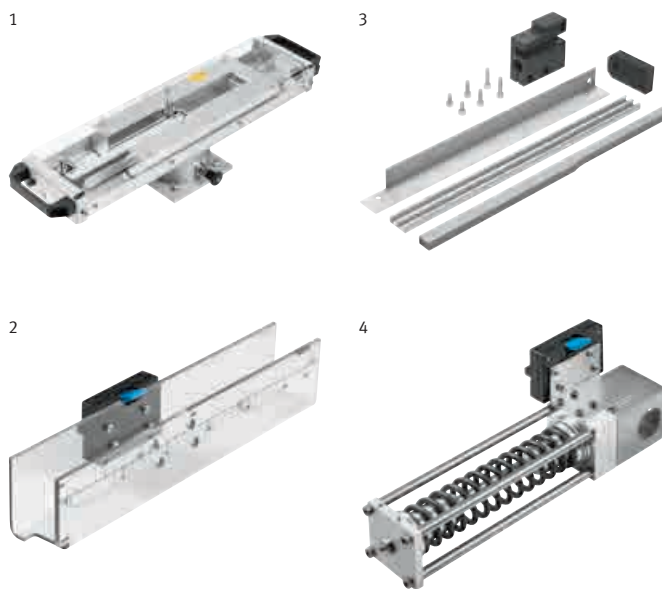

Hydraulics

Drives

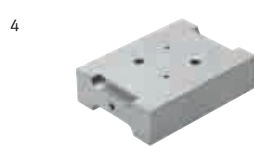

1/2 Displacement encoder for cylinder

- Linear potentiometer for installing on cylinders using a mounting kit.
- Connecting cable with 4 mm safety plug
- Output: 0 – 10 V (DC)

1 Linear potentiometer with 200 mm measuring stroke

- For cylinders order no. 572746 and 572750 with mounting kit order no. 544371 or
- For cylinders order no. 572747 with mounting kit order no. 544373

200 mm stroke **167090**

Linear potentiometer with 300 mm measuring stroke

- For cylinders order no. 572748 with mounting kit order no. 544372

300 mm stroke **525953**

2 Linear potentiometer with 450 mm measuring stroke

- For direct mounting on cylinders order no. 184488 and aluminum profile plate

450 mm stroke **525954**

3 Linear drive

Comprising a slide, double-acting cylinder, guide rods, cover with scale, yoke and mounting material. Integrated displacement encoder (linear potentiometer) with 200 mm stroke, connection with 4 mm safety plugs and 0 – 10 V DC output.

- Operating pressure: 6 MPa (60 bar)
- Maximum permissible pressure: 12 MPa (120 bar)
- Low-leakage, self-sealing coupling-nipples
- Piston Ø 16 mm
- Piston rod Ø 10 mm
- Stroke 200 mm
- Surface area ratio 1:1.6

Order no. **8028726**

4 Weight, 5 kg, for linear drive

Weight for mounting on the linear drives (order no. 8028726 and order no. 167089), to be used as additional load.

Order no. **34065**

Hydraulics

Drives

1 Cushioning cylinder for linear drive

- Load/cushioning cylinder for a linear drive unit (order no. 167089)
 - Operating pressure: 6 MPa (60 bar)
 - Maximum permissible pressure: 12 MPa (120 bar)
 - Double-acting
 - Low-leakage, self-sealing coupling nipples
 - Piston Ø: 16 mm
 - Piston rod Ø: 10 mm
 - Stroke: 200 mm
 - Surface area ratio 1 : 1.6
- Order no. **152295**

2 Weight, 9 kg, for cylinder

- Weight for mounting on a Learnline profile column. Can be used as the driving or tractive load of a hydraulic cylinder. With clevis and plain-bearing guide. For cylinder: order no. 152857, 572746, 572750
- Order no. **152972**

3/4 Protective cover for weight, 9 kg

- Protects reliably against injury. Only in combination with cylinder, order no. 152857, 572746, 572750 and weight, order no. 152972.

3 For the Learntop-S mounting kit

Order no. **152973**

4 Für die Learnline-Profilesäule

Order no. **541135**

5 Hydraulic motor

- The motor rotates because of the flow passing through it. When the direction of flow is changed, the direction of rotation changes as well. Leakage in the motor is conveyed to the lower-pressure side via the shuttle valve.

- Operating pressure: 6 MPa (60 bar)
- Maximum permissible pressure: 12 MPa (120 bar)
- Maximum permissible pressure in the return line 5 MPa (50 bar)
- Displacement: 8.2 cm³ per revolution, 0 – 10 l/min equates to 0 – 1220 r.p.m.
- Design: orbit
- Low-leakage, self-sealing coupling nipples
- Quick action mounting system Quick-Fix

Order no. **152858**

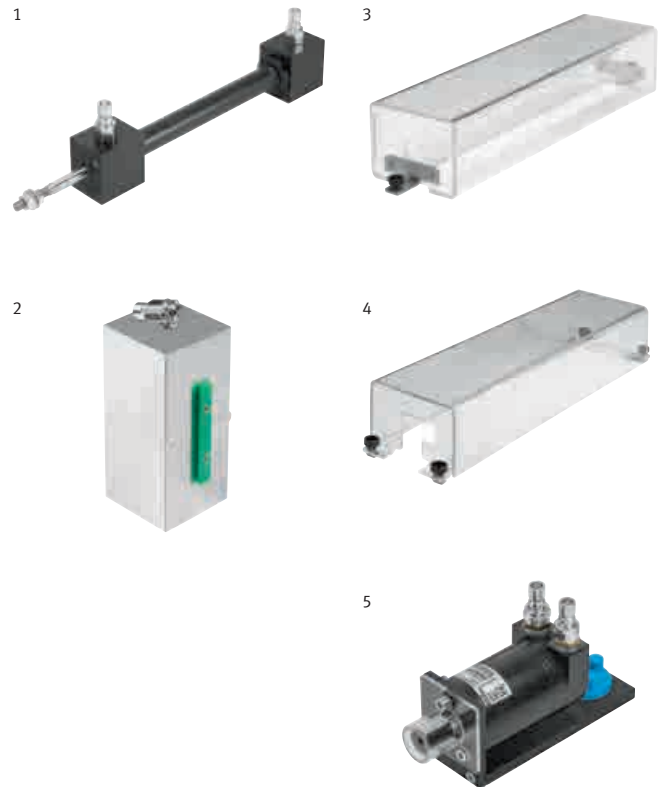

Hydraulics

Accessories and optional components



1 Hose line with quick release couplings

The high-pressure hose consists of three layers: The innermost layer is synthetic rubber, followed by a wire mesh, and sheath of abrasion-resistant synthetic rubber. The quick coupling sockets are self-sealing when decoupled. Used with a coupling nipple, the coupling sockets form a tightly sealed connection. Only the face of the coupling is coated with oil during the coupling process. Coupling and decoupling are only permissible when the hose is de-pressurised.

- Operating pressure: 6 MPa (60 bar)
- Max. permissible pressure: 12 MPa (120 bar)
- Temperature range: -40 – + 125 °C
- Min. bending radius: 100 mm
- DN 06 (Ø 6,3 mm)

600 mm	152960
1000 mm	152970
1500 mm	159386
3000 mm	158352



2/3 Coupling socket

- Maximum permissible pressure: 12 MPa (120 bar)
- Low-leakage, self-sealing quick coupling socket
- G $\frac{1}{4}$ " thread

2 Internal thread	567223
3 External thread	548610



4 Coupling nipple

- Maximum permissible pressure: 12 MPa (120 bar)
- Low-leakage, self-sealing coupling nipple
- G $\frac{1}{4}$ " male thread

Order no.	342047
-----------	--------



Blanking plug

To seal off connecting threads that are not needed.

- Maximum permissible pressure: 12 MPa (120 bar)
- G $\frac{1}{4}$ " male thread

Order no.	205284
-----------	--------



Resistance hose line with quick release couplings

DN 04 (Ø 4 mm)

1000 mm	549858
---------	--------

Hose line without quick release couplings

With G $\frac{1}{4}$ " external thread and spanner flat (AF19).



Please observe the following safety rules: Hoses should not be used for longer than 6 years, including a storage period of 2 years.

600 mm	337617
1000 mm	337618
1500 mm	350337
3000 mm	343616



5 T-distributor

The distributor can be inserted at any point.

- Ports: 2x coupling nipples and 1x quick coupling socket
- Maximum permissible pressure: 12 MPa (120 bar)
- Low-leakage, self-sealing couplings

Order no.	152847
-----------	--------

6 4-way distributor

Distributor with five ports.

- Maximum permissible pressure: 12 MPa (120 bar)
- Low-leakage, self-sealing coupling nipples
- Quick action mounting system Quick-Fix

Order no.	184455
-----------	--------

7 4-way distributor with pressure gauge

The distributor with five ports is equipped with a pressure gauge and is firmly screwed to the profile plate.

- Effective range and maximum permissible pressure 10 MPa (100 bar)
- Quality class 1.6% of the full scale value
- Operating pressure, static: 3/4 of the full scale value
- Operating pressure, dynamic: 2/3 of the full scale value
- Cushioning: glycerine
- Low-leakage, self-sealing coupling nipples

Order no.	159395
-----------	--------

Hydraulics

Accessories and optional components

1 4-way return header, unpressurized

Plate with five ports to bring together multiple safety-oriented return lines. The open quick-coupling plug is routed back to the tank of the hydraulic power unit.

- Maximum permissible pressure: 1 MPa (10 bar)
- Four self-sealing quick-coupling sockets
- A tube (2 m) with open quick-coupling plug

Order no. **573026**

2 Tubing line for unpressurized return

For connecting open connection fittings to the return header or the plug socket on the hydraulic power unit.

- Maximum permissible pressure: 1 MPa (10 bar)
- One side with open quick coupling plug, one side with quick coupling socket
- Length 1200 mm

Order no. **573024**

3 Pressure relief unit

The pressure relief unit is attached to the low-leakage, self-sealing coupling nipple so it can be forced open without requiring much power. This allows trapped hydraulic pressures to be relieved.

Order no. **152971**

4 Base plate

Base plates with four G $\frac{1}{4}$ " threaded connections and valve port patterns to ISO/DIN 4401. For the adaptation of any valves.

- Quick action mounting system Quick-Fix

Size 02 (NG4) port pattern, B left, A right

Order no. **572152**

Size 02 (NG4) port pattern, A left, B right

Order no. **572153**

Size 03 (NG6) port pattern, B left, A right

Order no. **669198**

Size 03 (NG6) port pattern, A left, B right

Order no. **750227**

5 Diaphragm accumulator with shut-off block

With the three-way ball valve integrated in the shut-off block, the following functions are possible:

1. Open connection between P and the diaphragm accumulator
 2. Closed connection between P and the diaphragm accumulator
 3. Open connection between T and the diaphragm accumulator (relief)
- Safety valve against overload
 - Pressure gauge for working pressure
 - Rated volume 0.32 dm³
 - Medium, gas side: nitrogen (N)
 - Gas charging pressure when delivered: p 1 MPa (10 bar)
 - Operating pressure 6 MPa: (60 bar)
 - Maximum permissible pressure: 12 MPa (120 bar)
 - Low-leakage, self-sealing coupling nipple for P
 - Tube with open quick-coupling plug for T
 - Material for mounting on the profile plate

Order no. **152859**

Accumulator filling device

For filling or topping up the gas side of the diaphragm accumulator (order no. 152859) with nitrogen (N). The accumulator filling device can be operated directly using a standard commercially available nitrogen bottle. If a pressure reducer is used, manufacturer-specific adapters may be required.

Order no. **92491**

6 Pressure filter, 5 μ m

Placed directly downstream of the pump, the pressure filter reliably protects the following hydraulic elements from solids suspended in the oil. The required purity class is determined by the most sensitive element in the system.

- Pore size of the filter: 5 μ m
- Contamination indicator
- Maximum permissible pressure: 12 MPa (120 bar)
- Low-leakage, self-sealing coupling nipples
- Quick action mounting system Quick-Fix

Order no. **548609**

Replacement filter cartridge for the pressure filter

Order no. **236302**



Hydraulics

Sensors/Measuring Technology



1 Pressure gauge

The pressure gauge can be inserted at any point for pressure measurement.

- Effective range and maximum permissible pressure: 10 MPa (100 bar)
- Quality class 1.6% of the full scale value
- Operating pressure, static: 3/4 of full scale value
- Operating pressure, dynamic: 2/3 of full scale value
- Cushioning: glycerine
- Low-leakage, self-sealing couplings

Order no. **152841**

2 Pressure sensor

The pressure sensor can be inserted at any point for pressure measurement and has an analog output.

- Operating voltage 15 – 30 V DC
- Effective range and maximum permissible pressure: 10 MPa (100 bar)
- Analog output 0 – 10 V
- Electrical connection on 4 mm safety plug
- Low-leakage, self-sealing couplings

Order no. **525964**

3 Pressure switch, electronic

The pressure switch can be inserted at any point for pressure measurement and has two switching outputs and an analog output.

- Operating voltage 18 – 35 V DC
- Switching outputs 2 x PNP, maximum 1.2 A
- Effective range and maximum permissible pressure: 10 MPa (100 bar)
- Analog output 0 – 10 V
- 4-digit digital display, can be rotated along 2 axes
- Electrical connection M12, 5-pin on 4 mm safety plug
- Low-leakage, self-sealing couplings

Order no. **548612**

4 Temperature sensor

The sensor can be inserted at any point for temperature measurement and has an analog output.

- Maximum permissible pressure: 12 MPa (120 bar)
- Operating voltage 20 – 30 V DC
- Measuring range 0 – 100 °C
- Analog output 0 – 10 V
- Electrical connection on 4 mm safety plug
- Low-leakage, self-sealing couplings

Order no. **525963**

5 Measuring case

The complete measuring set is packaged in the practical and sturdy Systainer. It can be used for commissioning, maintenance, troubleshooting and optimization of hydraulic circuits.

Complete measuring case, consisting of:

- Flow rate measuring device, electronic: 0 – 10 V analog output corresponds to 0 – 10 liters per minute or 0 – 1220 1220 r.p.m.
- Can only be operated with a hydraulic motor (order no. 152858): order no. 567191
- Measuring line, 500 mm, red: order no. 376937
- Measuring line, 500 mm, blue: order no. 376936
- Digital multimeter: order no. 8040005
- Pressure sensor, measuring range 0 – 10 MPa (0 – 100 bar), nominal size 4: order no. 525964
- Temperature sensor, measuring range 0 – 100 °C, nominal size 4: order no. 525963

Order no. **177468**

Hydraulics

Sensors/Measuring Technology

1 Sight glass flow indicator

The oil flow and cavitation can be observed through the sight glass. The float acts as an indicator for the flow direction and flow rate.

- Display range up to +/- 4 l/min
- Operating pressure: 6 MPa (60 bar)
- Maximum permissible pressure: 12 MPa (120 bar)
- Low-leakage, self-sealing coupling nipples
- Quick-action mounting system Quick-Fix

Order no. **3492037**

2 Flow indicator with float

Mechanical flow indicator according to the float principle for measuring flow in l/min und gal/min (US).

- Can be used whatever the position (spring return)
- Directly readable
- Measuring range: 0.5 – 4.5 l/min or 0.1 – 1.2 gal/min
- Maximum permissible pressure: 12 MPa (120 bar)
- Low-leakage, self-sealing couplings

Order no. **4857121**

3 Measuring container for hydraulic oil

The transparent measuring container is equipped with a stabilized inlet, a normal inlet, and an inlet for unpressurized return. There is also a scale, protection against overflow, and a manually opened outflow. For mounting on Learnline, the universal bracket (order no. 539736) is required. Measuring range up to 2 liters.

Order no. **541134**

4 Flow sensor

The sensor is connected to the hydraulic motor (order no. 152858). A tachometer generator transforms the rotational speed of the hydraulic motor into DC voltage. The speed of the hydraulic motor from 0 – 1220 r.p.m. equates to a voltage of 0 – 10 V and a flow rate of 0 – 10 l/min.

- Clockwise/counter-clockwise rotation: output as analog value from 0 – 10 V
- Operating voltage: 24 V DC
- Measuring range 0 – 10 l/min
- Analog output 0 – 10 V
- Electrical connection on 4 mm safety sockets

Order no. **567191**

1

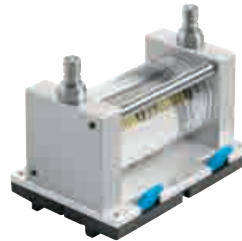

3



2



4



Hydraulics

Power packs



1 Hydraulic power pack with two constant-displacement pumps

Especially suitable for separate supply of two hydraulic circuits, each with its own ON/OFF switch e.g. on a mobile Learnline workstation. Equally recommended for reaching higher speeds in cylinders and motors. Also ideal for producing valve characteristic curves.

- Can be integrated into mobile Learnline workstation systems
- Pump design: 2x external gear motor each with pressure relief valve adjustable from 0 – 6 MPa (0 – 60 bar)
- Operating pressure: 6 MPa (60 bar)
- Two motors with overload protection, each with an ON/OFF switch on the Quick-Fix mounting system
- Rated output: 2 x 550 W
- Tank: 40 l volume, sight glass, temperature display, drain screw
- Tank lid with air filter and return filter
- Low-leakage, self-sealing coupling nipples for P and T
- Plug socket for unpressurized return
- Connecting flange for measuring container return
- Dimensions: 700 x 320 x 550 mm (W x D x H)
- Weight: 72 kg (empty)

Variant for AC 230 V/50 Hz

- Power pack with AC motors, single-phase and start capacitors
- Delivery rate: 2 x 3,4 l/min

Order no. **541114**

Variant for AC 120 V/60 Hz

- Power pack with AC motors, single-phase and start capacitors
- Delivery rate: 2 x 4.3 l/min (2 x 1.1 gpm)

Order no. **8064373**

Variant for AC 400 V/50 Hz

- Power pack with AC motors, three-phase
- Delivery rate: 2 x 3.4 l/min

Order no. **541116**

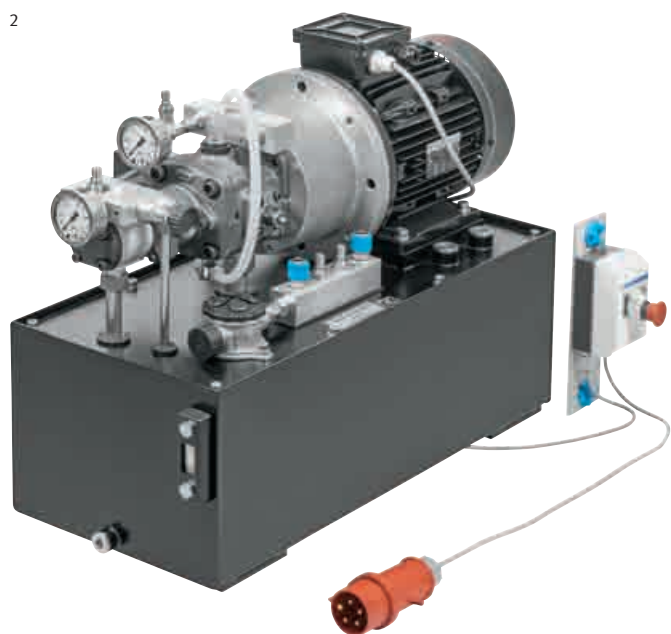

2 Hydraulic power pack with LS variable and constant displacement pump combination

Especially well-suited to all tests with the TP 800 standard equipment sets and other mobile hydraulics applications, especially processes controlled with load sensing (LS).

- Can be integrated into mobile Learnline workstation systems
- Pumps: axial piston pump with hydraulic load-sensing controller limited to 4 l/min (1 gpm) delivery rate and external gear pump with pressure-relief valve adjustable to 0 – 6 MPa (0 – 60 bar)
- Operating pressure: 6 MPa (60 bar)
- Motor with overload protection and an ON/OFF switch on quick action mounting system Quick-Fix
- Rated output: 1.1 kW
- Tank: 40 l, sight glass, temperature display, drain screw
- Tank lid with air filter and return filter
- Low-leakage, self-sealing coupling nipples for P and T
- Plug socket for unpressurized return
- Connecting flange for measuring container return
- Dimensions: 700 x 320 x 550 mm (W x D x H)
- Weight: 105 kg (empty)

Variant for AC 230 V/50 Hz

- Power pack with AC motors, single-phase and start capacitors
- Delivery rate of constant displacement: 3.8 l/min

Order no. **8065075**

Variant for AC 208 V/60 Hz

- Power pack with AC motors, three-phase
- Delivery rate of constant displacement: 4.5 l/min (1.2 gpm)

Order no. **8073527**

Variant for AC 400 V/50 Hz

- Power pack with AC motors, three-phase
- Delivery rate of constant displacement: 3.8 l/min

Order no. **8065076**

Hydraulics

Power packs

1 Hydraulic power pack with two constant-displacement pumps and one motor

Recommended for reaching higher speeds in cylinders and motors. Also ideal for producing valve characteristic curves.

- Can be integrated into mobile Learnline workstation systems
- Pump design: 2 x external gear motors, each with pressure relief valve adjustable from 0 – 6 MPa (0 – 60 bar)
- Operating pressure: 6 MPa (60 bar)
- Motor with overload protection, and ON/OFF switch on Quick-Fix mounting system
- Rated output: 1.1 kW
- Tank: 40 l volume, sight glass, temperature display, drain screw
- Tank lid with air filter and return filter
- Low-leakage, self-sealing coupling nipples for P and T
- Plug socket for unpressurized return
- Connecting flange for measuring container return
- Dimensions: 700 x 320 x 550 mm (W x D x H)
- Weight: 65 kg (empty)

Variant for AC 230 V/50 Hz

- Power pack with AC motor, single-phase and start capacitor
- Delivery rate: 2 x 3.6 l/min

Order no. **539733**

Variant for AC 400 V/50 Hz

- Power pack with three-phase AC motor
- Delivery rate: 2 x 3.7 l/min

Order no. **541115**

2 Hydraulic power pack with a constant-displacement pump

Ideal for individual hydraulic workstations for all experiments using standard equipment sets TP 500, TP 600 and the MPS® punching station.

- Mounting on Learnline with universal bracket (order no. 539736)
- Mounting on Learntop-S: direct
- Pump design: external gear motor with pressure relief valve adjustable from 0 – 6 MPa (0 – 60 bar)
- Operating pressure: 6 MPa (60 bar)
- Motor: AC, single-phase with overload protection, start capacitor, and ON/OFF switch
- Tank: 5 l volume, sight glass, temperature display, drain screw
- Air filter and return filter
- Low-leakage, self-sealing coupling nipples for P and T
- Plug socket for unpressurized return
- Connecting flange for measuring container return
- Dimensions: 580 x 300 x 180 mm (W x D x H)
- Weight: 19 kg (empty)

Variant for AC 220 – 230 V/50 – 60 Hz

- Rated output: 650 W
- Delivery rate: 2.3 - 2.7 l/min

Order no. **152962**

Variant for AC 120 V/60 Hz

- Rated output: 450 W
- Delivery rate: 2.7 l/min (0.7 gpm)

Order no. **8065049**

3 Wheel set for mounting on the tank

- Suitable for hydraulic power units with 40 l tank
- Four guide rollers, two with locking brake
- Mounting material included

Order no. **539734**

4 Hydraulic oil (DIN 51524)

Brand-name hydraulic oil for all Festo hydraulic power units.

HLP22, 10 Liters

Order no. **192215**

HLP22, 20 Liters

Order no. **14572**

Funnel

Funnel for filling various devices with oil.

Order no. **374038**



All 230 V power packs with power plug CEE 7, suitable for: DE, FR, NO, SE, FI, PT, ES, AT, NL, BE, GR, TR, IT, DK, IR, ID.

Note:
For safety reasons the hydraulic power packs are not filled with oil when delivered. Please order the oil separately.

Measurement and control electronics



1/2 Signal input, electrical

The device contains an illuminated push-button switch (control switch) and three illuminated push-buttons (momentary contact switches) with terminals and two buses for power supply.

- Contact set: 1 makes, 1 breaks
- Contact load: Maximum 2 A
- Power consumption (Miniature bulb): 0.48 W

1 Symbols according to IEC standard

Order no. **162242**

2 Symbols according to NEMA standard

Order no. **8062950**

3 Indicator unit and distributor, electrical

The device contains an acoustic indicator and eight lamps with terminals and three buses for power supply. Through-contact socket pairs per lamp allow the element to also be used as a distributor.

- Power consumption acoustic indicator: 0.04 W
- Power consumption indicator lamps: 1.2 W
- Frequency acoustic indicator: 420 Hz

Order no. **162244**

4/5 Relay, three-fold

The device has three relays with terminals and two buses for power supply.

- Contact load: max. 5 A
- Cut-off load: max. 90 W
- Pick-up time: 10 ms
- Drop-off time: 8 ms

4 Symbols according to IEC standard

Order no. **162241**

5 Symbols according to NEMA standard

Order no. **8062958**

6/7 Time relay, two-fold

The element contains a release-delay and a pickup-delay time relay. Both relays are infinitely variable, using the rotary knob of the potentiometer.

- Contact set: 2 makes, 2 breaks
- Contact load: Maximum 5 A
- Cut-off load: Maximum 100 W
- Delay: 0.5 – 10 s adjustable

6 Symbols according to IEC standard

Order no. **162243**

7 Symbols according to NEMA standard

Order no. **8062960**

8/9 Preset counter, electronic

Electronic preset counter with terminals for count pulse, contact set, and reset pulse, as well as bus bars for supply power.

- Contact set: 1 changeover contact
- Contact rating: max. 5 A
- Power consumption: 3 W
- Maximum counting rate: 30 Hz
- Preset value display: 4-place, red (counter reading) and yellow (preselection) illuminated
- Preset value programmable at each digit with up/down keys
- Reset key for manual resetting
- Lock key for locking the preset value

8 Symbols according to IEC standard

Order no. **1677856**

9 Symbols according to NEMA standard

Order no. **8062962**

Measurement and control electronics

1 Proportional amplifier

The amplifier allows control of proportional valves. It is designed so that it can either be driven by two independent solenoids (1 channel) or a valve with two solenoids (2 channel) such as a 4/3-way proportional valve. The proportional amplifier thus works either as a 1-channel amplifier or a 2-channel amplifier. The inputs are short-circuit protected or surge-proof up to 24 V.

- Setpoint values: ± 10 V DC in steps of 100 mV
- Switching signal for internal setpoint values: 15 – 30 V DC
- Solenoid outputs: PWM signal, 24 V, max. 1 A
- Enabling switching signal: 15 – 30 V DC
- Basic current, Jump current: 0 – 250 mA, in steps of 1 mA
- Maximum current: 100 mA – 1 A, in steps of 5 mA
- Dither frequency: 100 – 250 Hz, in steps of 1 Hz

Order no. **162255**

2 Setpoint value card

The setpoint value card has the following functions:

- Programmable setpoint generation
- Programmable ramp generation
- Cyclical sequencing of setpoints and ramps
- Stopwatch
- Number of setpoint values: 8
- Output voltage range: -10 – $+10$ V tol. ± 5 mV (adjustable in steps of 0.1 V)
- Number of ramps: 4
- Ramp times: 0 – 10.0 s/1 V (adjustable in steps of 50 ms/1 V)
- Activating voltage of inputs: Min. 15 V
- Output rate: 1 kHz
- Stop watch: Input 1, measuring time 0 – 100 hrs.

Order no. **162256**

3 Comparator

Positive switching comparator with hysteresis. The inputs are short-circuit-proof or surge-proof to 24 V. 2 separate inputs (IN A, IN B) each acting on two independent comparators. Each comparator can be set to:

- Reference voltage (-10 – $+10$ V), Hysteresis (0 – $+5$ V).
- Input voltage (inputs A and B): -10 – $+10$ V
- Input resistance (inputs A and B): > 10 k Ω
- Display accuracy: ± 30 mV
- Outputs A and B: Floating relay contacts, changeover contacts
- Contact load: 24 V DC/2 A and 120 V AC/1 A

Order no. **162257**

4 PID controller

PID controller for pneumatic and hydraulic control circuits. The controller comprises the following:

- Voltage supply
- Differential inputs
- Comparators
- Final control elements: positional control elements, speed control elements, acceleration control elements (status controller), proportional control elements, integral control elements (PID controller)
- Overall gain (Status controller)
- Correcting variable offset
- Summing junction
- Limiter
- Output

Order no. **162254**

5 Status controller

The status controller is used as a regulator in pneumatic and hydraulic position control circuits. The controller comprises the following:

- Voltage supply
- Differential inputs
- Comparators
- Final control elements: positional control elements, speed control elements, acceleration control elements (status controller), proportional control elements, integral control elements (PID controller)
- Overall gain (Status controller)
- Correcting variable offset
- Summing junction
- Limiter
- Output

Order no. **162253**



Measurement and control electronics



1 Function generator/counter/stopwatch

Multi-function device: function generator, counter, and stop-watch.

Order no. **544315**



2 Operational status display

For easy connection and for display of various operating modes and statuses by flashing and continuous signals in various colors. Three LED illuminating elements (green, yellow, red), each with socket for continuous light und flashing light, supply voltage sockets each 6 x 24 V DC and 0 V, all sockets designed for 4 mm safety plugs, mounting via protection device (against accidental contact) with integrated locking strip in the ER mounting frame for electrical connection and control units.

Order no. **567263**



3 Mushroom-head safety switch

With two-circuit switch-off and self monitoring, removable. The two N/C contacts open when the mushroom-head safety switch is pressed. An additional N/O contact is actuated when the mushroom-head safety switch is attached and opens when the mushroom-head safety switch is removed or interfered with. Supply voltage sockets each 6 x 24 V DC and 0 V, all sockets designed for 4 mm safety plugs, mounting via protection device (against accidental contact) with integrated locking strip in the ER mounting frame for electrical connection and control units.

Order no. **567261**



5 Terminal strip and distributor, electrical

The device contains six numbered terminal strips and three bus bars for the power supply. Like an industrial terminal strip, this can be divided into control, jumper; and field level. Rows of sockets connected with a potential can be bridged with 19 mm safety jumper plugs (not included).

Order no. **3584313**



4 Safety relay for emergency stop and safety door

With four positively-driven relay outputs and two input channels, can be used as a safety door monitoring device or for emergency stop monitoring.

- Operating modes: startup testing, short circuit detection, self test, automatic start, single-channel, manual start, manual start with monitoring, without short circuit detection, two-channel
- 3 safety contacts (N/O contacts), undelayed
- 1 auxiliary contact (N/C contact), undelayed
- 1 semiconductor output
- Supply voltage 24 V DC
- Supply voltage sockets each 6 x 24 V DC and 0 V, all sockets designed for 4 mm safety plugs, mounting via protection device (against accidental contact) with integrated locking strip in an ER mounting frame for electrical connection and control units.

Order no. **567262**

6 Universal connection unit, digital (SysLink)

The universal connection unit connects all 4 mm safety plugs with the 24-pin system connector as per IEEE 488 (SysLink). It thus becomes a universal interface between units with 4 mm connection technology and devices equipped with SysLink connectors as per IEEE 488:

- Simple connection of actuators and sensors via 4 mm laboratory connectors with the EasyPort interface unit for FluidSIM®

Inputs:

- Three safety sockets each for eight three-wire sensors

Outputs:

- Two safety sockets each for eight actuators

Connections:

- 4 mm safety sockets for 24 V DC, SysLink connector (IEEE 488)
- I/O status display: Via LED

Order no. **162231**

7 Connection unit, analog

Using an analog cable (order no. 529141), the unit can also be used as an analog connection unit for the EduTrainer® PLC or EasyPort USB.

- Permissible voltage range: 22 – 27 V DC
- Reference: GND
- Four analog voltage inputs: Range: -10 V – +10 V (max. 30 V), input resistance: 200 kΩ
- Four analog current inputs: Range: 0 – 20 mA (max. -4 – +24 mA), input voltage: max. ±30 V
- Two analog outputs: Voltage: -10 – +10 V, short-circuit-proof, max. ±30 V, fuse-protected, current: max. 20 mA

Order no. **567232**



Sensors/Measuring technology

1/2/3/4 Proximity sensor

Proximity sensor with protection against polarity reversal, overload and short circuit.

- M12 design
- 360° rotatable, detenting every 15°
- Connection via the 4 mm safety connectors integrated in the Quick-Fix quick connector system
- Power supply 10 – 30 V DC
- N/O contact (PNP) starting function
- NEMA variant: Symbols as per NEMA standard
- Quick action mounting system Quick-Fix

1/2 Proximity sensor, optical, M12

Adjustable sensing distance of 70 – 300 mm, with LED

1 Symbols according to IEC standard

Order no. **572744**

2 Symbols according to NEMA standard

Order no. **8062967**

3 Proximity sensor, inductive, M12

Sensing distance of 0 – 4 mm

Order no. **548643**

4 Proximity sensor, capacitive, M12

Sensing distance of 0 – 4 mm

Order no. **548651**

5 Limit switch, electrical

The micro switch is actuated mechanically when the roller lever is pressed, for example, by the trip cam of a cylinder. The micro switch can be wired as a N/O contact, N/C contact or a changeover switch, using the 4 mm safety sockets integrated in the quick action mounting system Quick-Fix. Possible contact load: maximum 5 A.

Limit switch, electrical, left-actuated

Order no. **183322**

Limit switch, electrical, right-actuated

Order no. **183345**

6 Emergency stop push-button, electrical

Emergency stop push-button, consisting of an illuminated mushroom-head emergency button and a contact set with 1 make and 1 break. Accommodated in yellow plastic housing.

Emergency Stop switch in the form of an impact push-button, one normally-open contact, one normally-closed contact, connection for 4 mm safety plug with power supply bus-bar, mounting via anti-shock cover with integrated snap-in grip strip on mounting frame for electrical interface and control units or via plug adapters on profile panel.

- Actuator: mushroom-head key with detent ring
- Contact set: 1 make, 1 break
- Contact load limit: maximum 8 A

Order no. **183347**

7 Proximity sensor, electronic

Magneto-resistive proximity sensor, magnetically operated

- Connection via 4 mm safety connectors
- Switching output N/O contact (PNP) with switching status indication
- Overload and short-circuit proof, with reverse polarity protection
- Operating voltage 5 – 30 V DC
- Output current: max. 100 mA
- Switching time (on/off) max. 1 ms
- Mounting system for T-slot

Order no. **2342009**

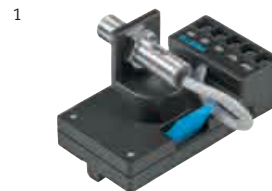

Sensors/Measuring technology



1 Contact tachometer

For measuring rotary speed on the hub of a hydraulic or compressed air motor.

- 5 – 99999 RPM (optical measurement)
- 0.5 – 19999 RPM (contact measurement)
- Last, minimum, or maximum measurement value can be saved

Order no. **8062148**

2 Beha-Amprobe AM-510 digital multimeter

Simple entry-level device for basic training.

- Automatic and manual range selection, 3¾-digit LCD display, measurement of direct and alternating voltage, direct and alternating current, resistance, continuity, flow diode test, capacity and frequency measurement.
- Voltage: 1 mV – 600 V
- Current: 0.1 µA – 10 A
- Resistance: 0.1 Ω – 40 MΩ
- Frequency: 1 Hz – 10 MHz
- Capacity: 0.01 nF – 100 µF
- Measuring circuit category CAT III/600 V

Scope of delivery

- Measuring leads
- Battery
- Operating instructions

Order no. **8040005**

3 Tektronix TBS1052B-EDU digital storage oscilloscope

Standard oscilloscope for observing relationships during basic training in electrical engineering. Curves can be traced and evaluated on a PC.

- Display: Color
- Bandwidth: 50 MHz
- Channels: 2
- Time base: 2,5 ns – 50 s/div
- Sampling rate: 1.0 GS/s
- Resolution: 8 bits
- Y deflection: 2 mV/div – 5 V/div
- Interface: USB

Scope of delivery

- Mains cable
- 2x TPP0051 probe
- Documentation

Order no. **571845**

4 Function generator

- Signal types: Sinusoidal, square, triangular, TTL
- Frequency range: 0.1 Hz – 500 kHz
- Voltage output: DC
- Offset: -15 – +15 V
- Voltage amplitude: 0 – 30 V

Order no. **152918**

5 Cable BNC – 4 mm

Cable with BNC socket and 2 jack-plugs (4 mm). For use in conjunction with a function generator and oscilloscope.

Order no. **152919**

Cable BNC – BNC

Order no. **158357**

T-piece BNC

Order no. **159298**

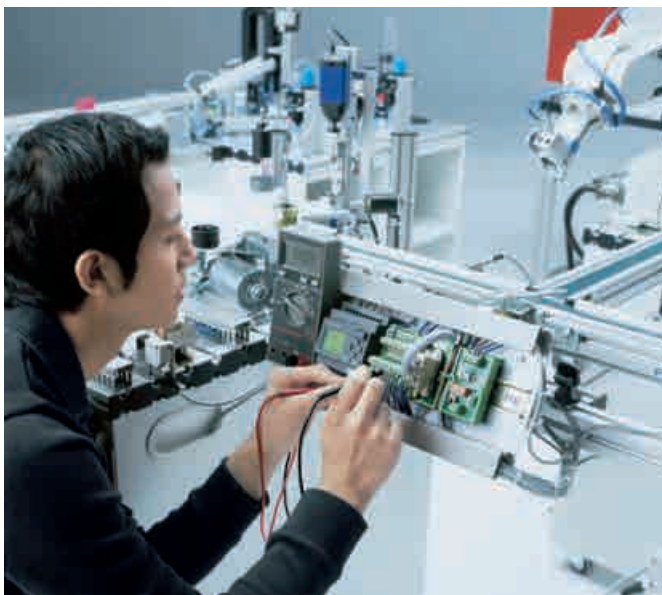

Accessories

Electrical power supply

1 Power supply unit for mounting frame

- Input voltage: 85 – 265 V AC (47 – 63 Hz)
- Output voltage: 24 V DC, short-circuit-proof
- Output current: max. 4 A
- Dimensions: 170 x 240 x 92 mm

Without power cable

Order no. **8049382**

Connector as per CEE 7/VII for DE, FR, NO, SE, FI, PT, ES, AT, NL, BE, GR, TR, IT, DK, IR, ID

Order no. **159396**

Connector as per NEMA 5-15 for US, CA, Central America, BR, CO, EC, KR, TW, TH, PH, JP

Order no. **162411**

Connector as per BS 1363 for GB, IE, MY, SG, UA, HK, AE

Order no. **162412**

Connector as per AS 3112 for AU, NZ, CN, AR

Order no. **162413**

Connector as per SEV 1011 for CH

Order no. **162414**

Connector as per SANS 164-1 for ZA, IN, PT, SG, HK, (GB), (AE)

Order no. **162415**

2 IEC power cable

One side designed as a connector and one side with a country-specific plug.

Connector as per CEE 7/VII for DE, FR, NO, SE, FI, PT, ES, AT, NL, BE, GR, TR, IT, DK, IR, ID

Order no. **247661**

Connector as per NEMA 5-15 for US, CA, Central America, BR, CO, EC, KR, TW, TH, PH, JP

Order no. **350362**

Connector as per BS 1363 for GB, IE, MY, SG, UA, HK, AE

Order no. **350363**

Connector as per AS 3112 for AU, NZ, CN, AR

Order no. **350364**

Connector as per SEV 1011 for CH

Order no. **350366**

Connector as per SANS 164-1 for ZA, IN, PT, SG, HK, (GB), (AE)

Order no. **350367**

3/4 4 mm Safety laboratory cables

- Plugs with rigid protective sleeve and axial socket
- Conductor cross section: 1 mm²
- 1000 V CAT II, Rated current: 16 A

3 4 mm Safety laboratory cables, 98 pieces, red, and blue

Complete set, consisting of 98 safety laboratory cables with 4 mm safety plugs in the colors red and blue:

- 10x red 50 mm
- 10x blue 50 mm
- 26x red 300 mm
- 11x blue 300 mm
- 21x red 500 mm
- 12x blue 500 mm
- 3x red 1000 mm
- 3x blue 1000 mm
- 1x red 1500 mm
- 1x blue 1500 mm

For the third cable color, safety laboratory cables, 47 pieces, black, are suitable (order no. 8092667)

Order no. **8092666**

4 4 mm Safety laboratory cables, 106 pieces, red, blue, and black

Complete set, consisting of 106 safety laboratory cables with 4 mm safety plugs in the colors red, blue, and black:

- 10x red 50 mm
- 10x blue 50 mm
- 8x black 50 mm
- 8x red 300 mm
- 8x blue 300 mm
- 18x black 300 mm
- 8x red 500 mm
- 8x blue 500 mm
- 18x black 500 mm
- 2x red 1000 mm
- 3x blue 1000 mm
- 2x black 1000 mm
- 1x red 1500 mm
- 1x blue 1500 mm
- 1x black 1500 mm

Order no. **8092668**

5 Measuring lead holder

Mobile measuring lead holder with storage box.

- Dimensions (W x H x D)
54 x 135 x 54 cm
- Storage dimensions (W x D)
42 x 51 cm

Order no. **8043430**

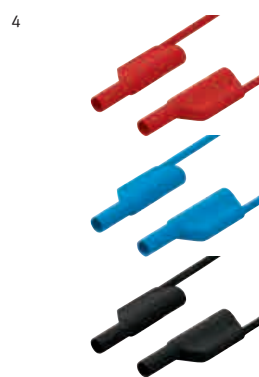
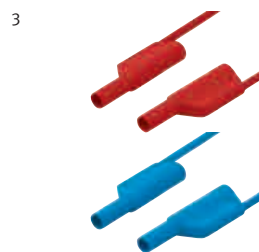

Accessories

Organizers



1/2/3/4/5 Systainer® with T-LOC system

Stackable and interlocking case system, made of light gray plastic with light blue T-LOC rotary locks, one-hand operation, for opening and interlocking the Systainers®. With four slots for credit-card-sized labels or markings.

Size I: external 105 x 396 x 296, internal 75 x 383 x 267

Order no. **8022295**

Size II: external 157.5 x 396 x 296, internal 127.5 x 383 x 267

Order no. **8022296**

Size III: external 210 x 396 x 296, internal 180 x 382 x 266

Order no. **8022297**

Size IV: external 315 x 396 x 296, internal 285 x 382 x 266

Order no. **8022298**

Size V: external 420 x 396 x 296, internal 384 x 381 x 265

Order no. **8022299**

(Dimensions in mm H x W x D).

6 Dolly truck for Systainer

Dolly truck for transporting T-LOC and Classic Line Systainers in sizes I to V. Four guide rollers, two with clamping brakes.

Order no. **549789**

7 Storage system for A4 EduTrainer®

Transport and storage system for A4 EduTrainer® and training packages.

Case with slotted foam sheets for holding A4 boards and permanently attached lid with a stop in the open position. The enclosed divider can be used to partition off an area for holding measuring devices and cables and also provides convenient access to an EduTrainer® with a width of 133 mm. The exterior consists of grained laminate with edges protected by metal profiles. The case features a sturdy folding handle, rubber feet, and two buckles that can be locked with padlocks.

Provides space for up to three A4 EduTrainers® with a width of up to 399 mm and additional accessories.

Order no. **8047571**

Accessories

Organizers

Systainer/Container Inserts

Didactic components need to be stored in a clearly arranged and safe way. Simply clamp two handles onto the narrow side of the insert of your choice and stack the inserts in the Systainer. Note: Two large and one small insert exactly fill a Learnline container drawer.

1 Systainer/Container Insert A

Dimensions (W x D): 351 x 172 mm.
For Systainers sizes 1 – 4.

Order no. **687927**

2 Systainer/Container Insert B

Dimensions (W x D): 351 x 264 mm.
For Systainers sizes 1 – 4.

Order no. **687461**

3 Systainer/Container Insert C

Dimensions (W x D): 351 x 264 mm.
For Systainers sizes 1 – 4.

Order no. **687929**

4 Systainer/Container Insert D

Dimensions (W x D): 351 x 264 mm.
For Systainers sizes 1 – 4.

Order no. **689087**

5 Systainer/Container Insert E

Dimensions (W x D): 351 x 264 mm.
For Systainers sizes 1 – 5.

Order no. **701309**

6 Systainer/Container Insert F

Dimensions (W x D): 351 x 264 mm.
For Systainers sizes 1 – 5.

Order no. **709844**

7 Systainer/Container Insert G

Dimensions (W x D): 351 x 264 mm.
For Systainers sizes 1 – 5.

Order no. **687943**

8 Systainer/Container Insert H

Dimensions (W x D): 351 x 264 mm.
For Systainers sizes 1 – 5.

Order no. **687944**

9 Systainer/Container Insert I

Dimensions (W x D): 351 x 264 mm.
For Systainers sizes 1 – 5.

Order no. **722009**

10 Systainer/Container Insert J

Dimensions (W x D): 351 x 264 mm.
For Systainers sizes 1 – 5.

Order no. **754668**

11 Systainer/Container Insert K

Dimensions (W x D): 351 x 264 mm.
For Systainers sizes 1 – 5.

Order no. **754701**

12 Systainer/Container Insert L

Dimensions (W x D): 351 x 172 mm.
For Systainers sizes 1 – 4.

Order no. **754704**

13/14/15 Handles for Systainer/Container Inserts

The handles are available in three different versions, suitable for Systainer sizes 2 – 5:

- Handle 80: 80 mm high version
- Handle 100: 100 mm high version
- Handle 150: 150 mm high version

When stacking the inserts in the Systainer, the handle height determines the distance between the stacked inserts. The handles can be used for all Systainer/container inserts. Two handles are required per insert.

13 Handle 80 **683012**

14 Handle 100 **687455**

15 Handle 150 **683464**

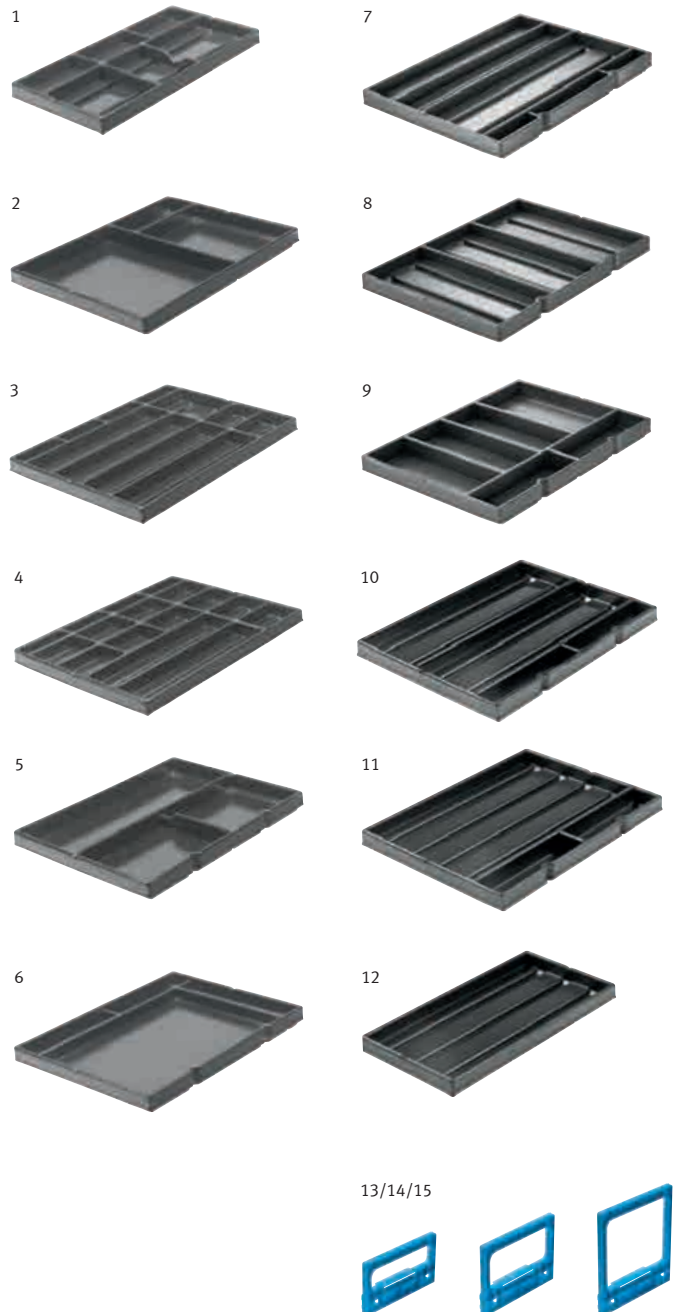

Services





Services164

Services

Make more of your potential



Service solutions tailored to your equipment and needs. A qualified team provides services that will enable you to maximize the capacity of your learning systems.

Knowing that your equipment is effectively maintained will allow you to focus on what is most important: teaching.



Worldwide availability? No problem. We are able to deliver our training services around the world in local languages to the high standard that both you and we require.



Installation, commissioning, and training will be carried out by qualified technicians in order to guarantee safe, efficient set-up and ensure that your team can use your new products immediately.



Free software, demos, and reading samples – For example, EasyVeep is a new graphic 2D process simulation software containing a number of attractive examples for PLC training that is available for download free of charge. You can sample for free many of our software products and all our books on the Internet using test and demo versions.



Service solutions to suit your needs

- Free delivery
- Commissioning
- Training
- Demos and reading samples
- Seminars
- Service contracts
- Extended warranty



Certification

Instructor certification trainings help you to get the best possible use out of your new learning system. Our qualified instructors introduce the equipment and provide the training material, as well as explain how to perform the exercises and integrate them quickly into your existing training programs. These training sessions can be conducted on your premises, at a Festo core location, or via video conference.



Festo is a global engineering and manufacturing company that maintains its own global training and consulting teams for customers all around the world.

Operating in the same economic sector and environment as our customers, we have a level of understanding and insight into your challenges that allows us to meet your needs by providing targeted training and consulting solutions.



Customized service contracts give you peace of mind as our team takes care of your equipment. Available services include on-site hardware maintenance and calibration, warranty extension and repairs, continuous instructor training, and much more.



Personal advice

We will be glad to provide an on-site consultation regarding concept and planning.

For more information, please contact your Festo contact person or write to: seminare@festo.com

Notes

A series of horizontal dotted lines for writing notes.

Publisher

Festo Didactic SE

P.O. Box 10 07 10
73707 Esslingen
Rechbergstraße 3
73770 Denkendorf
Germany

Edition: November 2019

Terms and conditions of sale

→ www.festo-didactic.com

As a result of continuous development and research work technical specifications and illustrations are subject to change. They are not binding. The specified data serves purely as a product description and is no guarantee in a legal sense.

All of the texts, diagrams, illustrations and drawings featured in this publication are the property of Festo Didactic SE and are thus protected under copyright.

Any reproduction, revision, translation, microfilming in any form, or storage and processing in electronic systems can only be undertaken with the written permission of Festo Didactic SE.





SNS Industrial Group

221 Holiday Inn Drive, Unit 102A
Cambridge Ontario N3C 3T2

www.snsindustrial.com

226-566-9677

Sales@snsindustrial.com

Festo Didactic SE

Rechbergstraße 3
73770 Denkendorf
Germany
Tel. +49 (711) 3467-0
Fax +49 (711) 347-54-88500
did@festo.com

Festo Didactic Inc.

607 Industrial Way West
07724 Eatontown,
New Jersey
United States
Tel. +1 (732) 938-2000
Fax +1 (732) 774-8573
services.didactic@festo.com

Festo Didactic Ltée/Ltd

675, Rue du Carbone
Québec, Québec, G2N 2K7
Canada
Tel. +1 (418) 849-1000
Fax +1 (418) 849-1666
services.didactic@festo.com

www.festo-didactic.com
www.labvolt.com