



Solutions for Power Switching, Power Monitoring, Power Conversion and Energy Storage

UL/CSA
Ed.4



POWER SWITCHING



POWER MONITORING



POWER CONVERSION



ENERGY STORAGE



EXPERT SERVICES

When **energy** matters





SNS Industrial Group

221 Holiday Inn Drive, Unit 102A
Cambridge Ontario N3C 3T2

www.snsindustrial.com
226-566-9677
Sales@snsindustrial.com

Notes



Contents

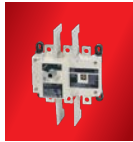

Non-fusible disconnect switches

Non-fusible disconnect switches for machine control and power distribution *p. 14*



Photovoltaic range

Photovoltaic non-fusible disconnect switches, fuse bases and fuses *p. 48*



Fusible disconnect switches

Fusible disconnect switches, fuse bases and fuses *p. 92*



Transfer switches

Manual, non-automatic & automatic transfer switches *p. 132*



Mounting, cable & accessories

All the components to facilitate the use of your electrical equipment *p. 172*



Enclosed disconnect solutions

Enclosed protection and switching devices ... *p. 199*



Metering, monitoring & power quality

Measurement and monitoring system, multifunction meters & supervision software *p. 208*



Power Conversion: UPS / STS

UPS and STS Solutions *p. 370*



Energy Storage Solutions

Energy Storage Solutions. *p. 382*

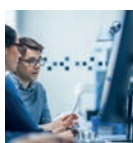

Expert Services

Expert Services *p. 392*



SIRCO M
UL 508
p. 16



SIRCO M
UL 98
p. 24



SIRCO
UL 98
p. 30



SIRCO
UL 98C
p. 38



SIRCO MC PV
p. 50



INOSYS LBS
p. 58



INOSYS ESS
p. 70



**SIRCO MAN
and MOT DC
& DC ESS**
p. 78



FP ESS
p. 82



FUSERBLOC
p. 94



**FUSERBLOC
DRIVE 1PP**
p. 110



RM CC
p. 118



RM and RMS
p. 122



COMO CS
p. 134



SIRCOVER
UL 98 & 1008
p. 140



ATyS
UL 1008
p. 152



ATyS FT/DT
p. 162



ATyS C66
p. 170



Power
distribution
blocks
p. 174



Rigid copper
bars
p. 178



Insulated
flexible copper
bars
p. 180



Insulated
copper braids
p. 182



Busbar
supports
p. 184



UL / NEMA 3R/12
Painted steel
p. 200



UL / NEMA 4, 4X
Fiberglass
p. 200



UL / NEMA 4, 4X
Stainless steel
p. 200



**UL / NEMA 1, 3,
3R, 12, 4, 4X**
Polycarbonate
p. 200



Multi-point
Power Metering
& monitoring
p. 240



Single-point
Power Metering
& monitoring
p. 284



Enclosed
Power Metering
& monitoring
p. 320



Current
Sensors
p. 348



Software
suite
p. 368



MODULYS GP-UL
p. 372



MASTERYS BC+ 208 V
p. 378



STATYS Integratable
p. 380



SUNSYS HES L
p. 384



SUNSYS HES XXL
p. 388

Ensuring the energy performance of your installations, wherever it is critical

When **energy** matters



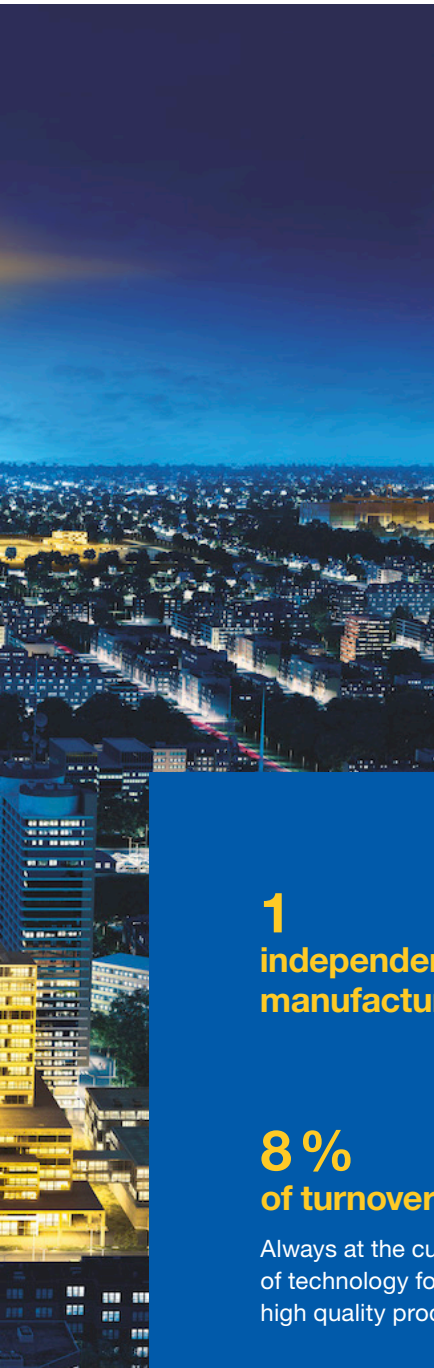

SYD/1514

For more than a century, Socomec, a family-owned industrial group, has been designing, manufacturing and selling a wide range of electrical equipment such as: inverters, measuring stations, energy storage, switches, automatic source switches, and more.
With a strong expertise in critical power applications, Socomec is an innovative player in energy transition and renewable energy.

Throughout its history, Socomec has constantly anticipated market changes by developing cutting-edge technologies, providing solutions that are adapted to customer requirements and fully in keeping with international standards. Expert in electrical networks and installations performance, Socomec improves the energy efficiency of electrical installations wherever it is critical: industry, infrastructure, healthcare, data center, energy and C&I buildings. With 12 production sites, 30 subsidiaries, products and services distributed in 80 countries by more than 100 distributors, Socomec accompanies you for a more secure, flexible and efficient energy.

100 years
OF SHARED ENERGY

1
independent
manufacturer

3,500 m²
of test platforms

One of the leading independent power testing labs in Europe

8 %
of turnover invested in R&D

Always at the cutting-edge of technology for innovative, high quality products

110,000
on-site interventions per year

Nearly 400 experts in commissioning, technical audit, consultancy and maintenance

Your energy, our expertise



Power switching

Managing power and protecting people, equipment and installations

Active in the industrial switching market since its foundation in 1922, Socomec is today an undisputed leader in the field of low voltage switchgear, providing expert solutions that ensure:

- isolation and on load breaking for the most demanding switching applications
- continuity of the power supply to electrical facilities via manual remotely operated or automatic transfer switching equipment
- protection of persons and assets via fusebased and other specialist solutions

Power monitoring

Improving energy performance and monitoring installations

Socomec solutions - from current sensors to power meters and from IOT to energy management software - are driven by experts in energy performance. They meet the requirements of facility managers and operators of commercial, industrial and critical buildings to enable and facilitate:

- the measurement of energy consumption, the identification of sources of excess consumption and the generation of awareness amongst occupants as to their impact
- the utilisation of the best available tariffs, utility bill checks and the accurate distribution of energy billing between consumer entities
- the limitation of reactive energy and avoidance of associated tariff penalties
- capacity management and the evolution of the electrical installation
- improvements to power availability by monitoring and detecting insulation faults

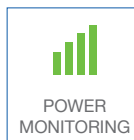

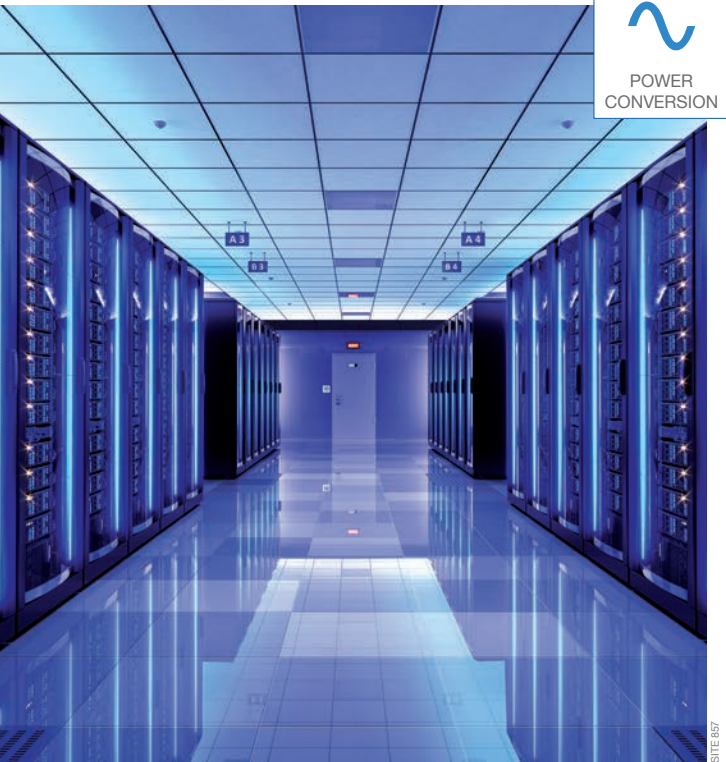

Power conversion

Ensuring the availability and storage of high quality power

With its wide range of continuously evolving products, solutions and services, Socomec are recognised experts in the cutting-edge technologies used for ensuring the highest availability of the electrical power supply to critical facilities and buildings, including:

- static uninterruptible power supplies (UPS) for high-quality power free of distortions and interruptions occurring on the primary power supply
- changeover of static, high availability sources for transferring the supply to an operational back-up source
- permanent monitoring of the electrical facilities to prevent failures and reduce operating losses
- energy storage for ensuring the proper energy mix of buildings and for stabilisation of the power grid

Energy storage

High power and scalable outdoor systems

An all-in-one range of outdoor Energy Storage Systems available in various sizes and features for on-grid and off-grid applications:

- modular energy storage system (ESS) can decouple energy production from consumption to better meet consumption needs
- harness the potential of renewable energy to charge batteries
- become more efficient in terms of UPS battery monitoring and maintenance to integrate these intermittent sources into the power grid

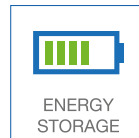



Your partner in expert services

Socomec is committed to delivering a wide range of value-added services to ensure the reliability and optimisation of end-users' equipment during its life cycle

- Prevention and service operations to reduce risk and enhance equipment efficiency.
- Measurement and analysis of a wide range of electrical parameters leading to recommendations for power quality improvement.
- Consultancy, deployment and training from the project engineering stage to the final procurement stage.



Specialists - at your service

Our Services team comprises qualified engineers whose mission is to ensure the correct operation of your equipment. We offer a comprehensive support service package which gives you complete peace of mind: commissioning, on-site testing, preventive maintenance visits, 24-hour call out and rapid on-site repairs, original spare parts, power quality and energy efficiency audits, consultancy, design and implementation of installation modifications and updates.

Our Services team is the most reliable partner when it comes to advising you on the maintenance of Socomec equipment and providing resolution to any problems in accordance with current environmental standards and procedures.



Professional tools

Our Services team is provided with the latest essential equipment including:

- Personal Protective Equipment (protective goggles, helmet, insulated gloves, fireproof jacket, safety shoes, earplugs...)
- laptop embedded with all software required to optimize equipment performance
- measuring equipment calibrated annually by our metrology department (multimeter, digital scope, current clamps, infra-red camera, power analyzer)



Reports

An exhaustive report is generated for each intervention (including commissioning, preventive maintenance and troubleshooting) which is then automatically sent to the customer and synchronized with our systems.



Remote diagnostics

In case of any anomaly, an automatic notification is sent to a local call center for proactive online troubleshooting.



Availability of original spare parts

The various original parts and components that we stock guarantee that any faulty equipment can be rapidly brought back online, whilst maintaining its original performance and reliability.

Key figures

Nearly 400 Socomec experts - supported by 200 engineers and technicians from across our distributor network - can provide the solutions to your specific needs.

- Subsidiaries
- Distributors
- Contact us

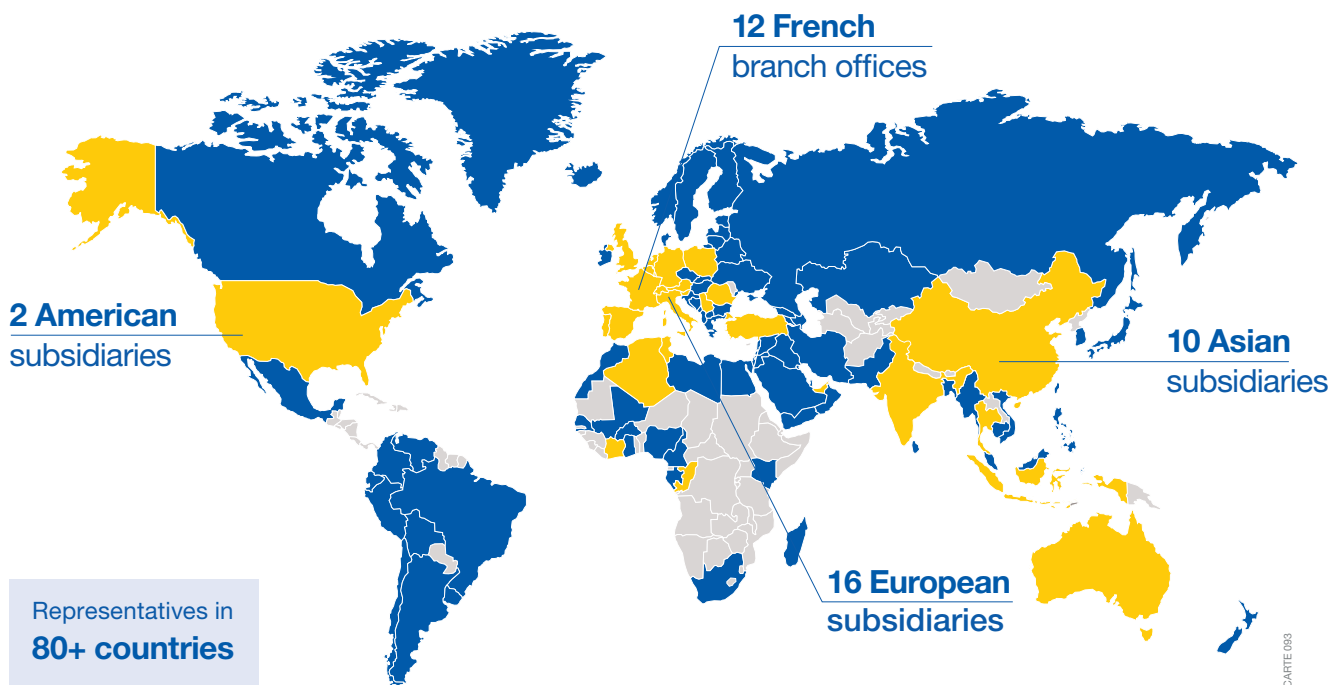

On-site service management



98%

Service Level Agreement compliance rate

Technical hotline network



25+

languages spoken

3

advanced technical support centres

Certified expertise



8,000

hours of technical training undertaken every year (product, methodology and safety)

A cutting-edge laboratory the backing of an expert

Created in 1965, SOCOMEC's laboratory brings its expertise to guarantee the reliability and the conformity of our products and solutions.

Since 2015, the laboratory renamed Tesla Lab – Power Testing and Certification in 2015, offers its testing and certification services to all its customers.

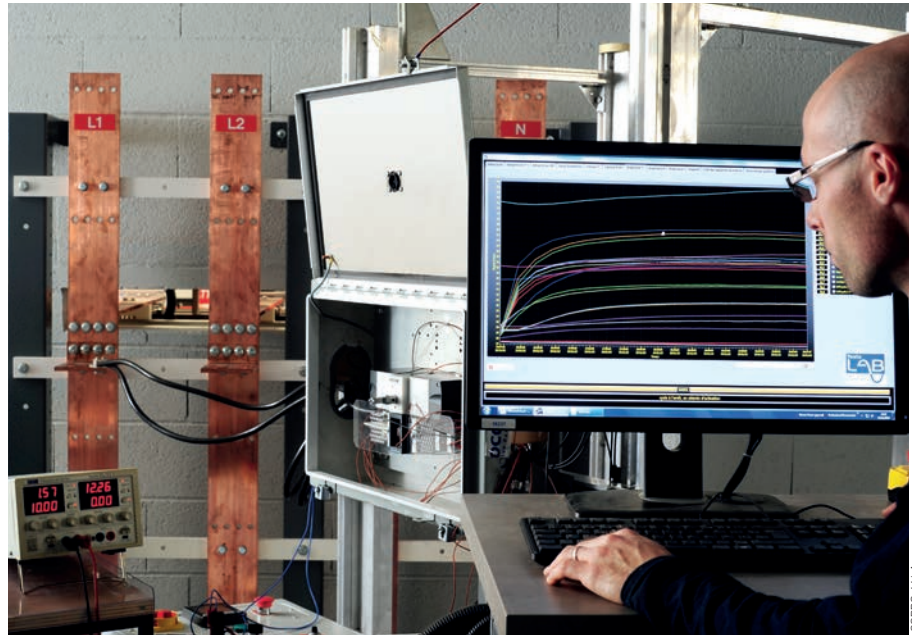

Proven expertise

Tesla Lab is an independent laboratory specialised in testing of LV switchgear, components and switchgear assemblies. 4 M€ has been invested since 2011 in this 2000 m² laboratory, where 30 experts guarantee the quality of the performed tests, making the Tesla Lab one of the most modern laboratories in Europe.

Vast range of tests

The laboratory has a 100 MVA (I_{cc} 100 kA rms 1 s) short-circuit platforms, three 10 kA overload platforms and many other test facilities covering 2000 m² for:

- functional tests
- mechanical tests: endurance
- dielectric tests
- environmental tests: vibration
- Ingress Protection (IP)
- temperature rise tests up to 60 °C ambient

International partnership

The laboratory is recognised by the major certification bodies worldwide: member of ASEFA and LOVAG, it is accredited by COFRAC, UL CTD, CSA (shared certification) and DEKRA (WMT).

The partnership with many international certification bodies guarantees the quality and safety requirements in each country.



Implementation of standard IEC / EN 61439

Electrical switchgear manufacturers

IEC/EN 61439 standards define the requirements of "Low voltage switchgear assemblies" as well as the tests necessary to ensure the achievement of the specified levels of performance. The compliance with these standards gives a guarantee of safety and performance to the user of the equipment



An original manufacturer according to IEC /

EN 61439 standards

Socomec offers a wide range of original manufacturer solutions complying with IEC/EN 61439 standards:

- FLEXYs and CADRYs cabinet systems designed for distribution panel applications.
- Local switching and equipment cabinets covering requirements in power availability and safety.
- Components for integration

Tesla Lab accredited by COFRAC

With its world-class testing facilities, the Tesla Lab can perform all of the tests required by IEC/EN 61439 standards for switchgear assemblies.

We can therefore help you to:

- define a verification program
- perform conformity tests
- issue test reports in order to get certification bodies (ASEFA, LOVAG, DEKAR, UL, CSA, COFRAC, ASTA...).

Expert in power conversion

maximizing power quality and availability



Socomec at the forefront of innovation

Proven expertise

Socomec's products are designed and developed by our talented team of in-house engineers with their real depth and wide knowledge in power electronics and digital controls. Our expertise in manufacturing - combined with the use of only the highest quality components in the most efficient production and testing processes – means that when it comes to reliability our products are unrivaled.

Socomec factories join the digital world

Since 2014, Socomec has been investing to bring its manufacturing facilities in line with industry 4.0 standards. Beyond lean manufacturing, the digitalization of production means that we can ensure the delivery of a competitive offering with continuously improving service levels whilst also supporting the creation of more personalised products.

Factory Acceptance Test (FAT)

The FAT service is available to all customers who want to audit their order before it leaves the factory. With the support of Socomec Platform Engineers and dedicated infrastructure, several live product tests are available, including:

- standard tests to verify product performance
- custom tests according to your precise requirements.



ELITE UPS: a mark of efficiency

Socomec, as CEMEP UPS manufacturer member, has signed a Code of Conduct put forward by the Joint Research Centre of the European Commission (JRC), to ensure the protection of critical applications and processes ensuring 24/7 continuous high quality supply.

The JRC commits to mitigating energy losses and gas emissions caused by UPS equipment, therefore maximizing UPS efficiency.

3 levels of UPS protection to keep your business up and running



PRIME

Trustworthy power

Reliable and cost effective UPS to assure operational continuity.



SUPERIOR

Unrivaled power performance

Best in class & certified UPS performance to optimize usage and Total Cost of Ownership (TCO).



ULTIMATE

Fault tolerant power without compromise

Ultimate UPS with fully redundant architecture for maximum availability, minimum MTTR and risk free maintenance.



ON
OFF

SIRCO 100A 27003011
General purpose switch 100A 600V_{a.c.} 3ph 50/60Hz
250V_{d.c.} 3 poles in series

V _{d.c.}	125	250
Max. HP	10	15
Poles in series	2	3

V _{a.c.}	240	480	600
1ph	3ph	3ph	3ph
Max. HP	10	30	75, 100

socomec LISTED OPEN TYPE SWITCH 46HM



CE

Use accessories according to instruction sheet: IS 537504

Use copper or aluminium wire

Use 75°C min. wire
Use of listed ZMFV lugs CMC, LA 300-R

Terminal tightening torque: 1600 N.m
This switch is suitable for use on a circuit capable of delivering not more than:
- 200kA rms symmetrical, 600V_{a.c.} max, when protected by class J fuses rated 100 amperes maximum
- 20kA, 250V_{d.c.}, when protected by 100A current limiting fuse type FEFRVAZ, A70P100

AC non-fusible disconnect switches

Selection guide..... p. 14

Non-fusible disconnect switches



SIRCO M
UL 508
16 to 100 A
p. 16



SIRCO M
UL 98
30 to 100 A
p.24



SIRCO
UL 98
100 to 1200 A
p. 30



SIRCO
UL 98C
400 to 1000 A
p. 38

Enclosed solution

SOCOMEC offers a range of pre-equipped enclosure in polyester, polycarbonate, stainless steel or painted steel.



Selection guide

Non-fusible disconnect switches

UL/CSA standards for disconnect switches

UL 98 - Enclosed and dead front switches (equivalent to CSA-C22.2 no 4)

These requirements cover enclosed or dead front switches doesn't need to be capitalized, with or without provision for fuses, at 600 V or less.

These products are used as disconnecting means without restrictions; they are heavy duty products requiring 2 inches (50 mm) minimum of creepage distance, which gives a maximum safety for users and installation. The short circuit withstand of these products goes up to 200 kA.

UL 489 - Molded case switches (equivalent to CSA-C22.2 no 5)

These requirements cover Molded-case Circuit Breaker, Molded case switches and fused Molded-case switches, rated at 600 volts or less and 6 000 amperes or less.

Typical control panel

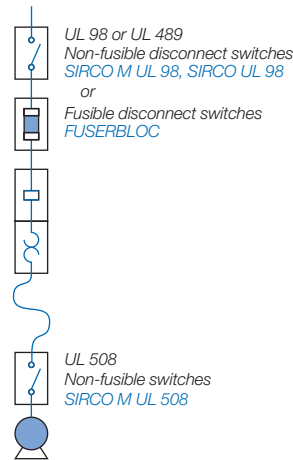

sirco-ul_022_b_1_dat



sircom_174_a

UL standards for electrical machinery





UL 508 - Industrial Control Equipment (equivalent to CSA-C22.2 no 14)

These requirements cover manual, starter, controllers, and overload don't need to be capitalized.

These products are IEC type products, requiring only a creepage distance between phases of 1/2 inch. UL 508 standard requested only 5 kA or 10 kA as short circuit withstand with fuse protection. Their use as a disconnecting mean is therefore limited to local disconnection of motors. These products can only be used as a disconnect mean when they have been additionally tested "suitable as motor disconnect". This additional testing ensures that the switch as a proper closing capacity on short circuit. UL 508 (switches or Circuit breakers) can not be used as main disconnect of a electrical panel. (i.e. in entrance of control panels).

A manual motor controller marked "Suitable as motor disconnect" shall be installed only on the load side of the branch circuit protective device (UL 508A 30.3.3 and NEC 430.109(6)).



Machine control		Power distribution	
			
SIRCO M UL 508 16 to 100 A	SIRCO M UL 98 30 to 100 A	SIRCO UL 98 100 to 1200 A	SIRCO UL 98C 400 to 1000 A

Applications

Main switchboard	•	•	•	
Distribution panel	•	•	•	
Emergency disconnect	•	•	•	
Genset output		•	•	
Network coupling		•	•	
Local safety disconnect	•	•	•	
Machine control	•	•		
Photovoltaic disconnect				•
Enclosed switches	•	•	•	

Functions

3/4 pole non-fusible disconnect switch	•	•	•	•
6/8 pole non-fusible disconnect switch	•			
3/4 pole changeover switch (I-0-II)	•			
3/4 pole changeover switch (I-I+II-II)	•			

Characteristics

Rating				
600 VAC	•	•	•	
800 VAC				•
Operation				
Manual (rotating)	•	•	•	•
Manual flange				
Manual toggle	•			
Direct operation handle				
Front	•	•	•	•
External operation handle				
Front	•	•	•	•
Right side	•	•		
Flange				
Indication of breaking				
Positive break indication	•	•	•	•
Switch body				
Modular	•	•		

SIRCO M UL 508

Non-fusible disconnect switches standards UL and CSA
from 16 to 100 A

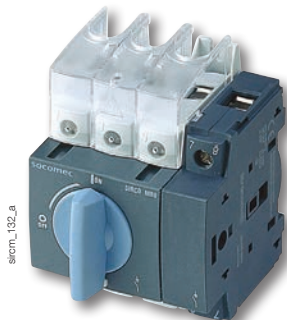

Rotary switch
SIRCO M2 3x80A



Toggle switch
SIRCO M2 3x80A + 2 auxiliary contacts



Rotary switch
SIRCO M2 3x80A

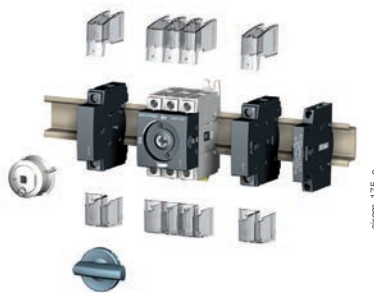

Function

SIRCO M UL/CSA are compact and modular non-fusible disconnect switches. They make and break under all types of load conditions and provide safe isolation for any low voltage circuit, especially for machine control circuits.

General characteristics

- Positive break indication.
- Direct or external operation.
- Compact footprint.
- DIN-rail, base or door mounting.
- Wide range of accessories.
- Up to 8 pole or 4 pole MTS.

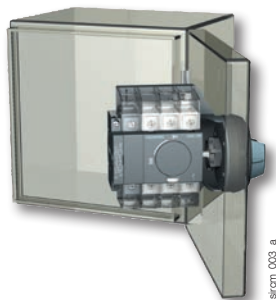

The solution for

- > OEM/Machine Builders
- > Industrial Control Panel Manufacturers (UL 508A)
- > Switchboard Manufacturers (UL 891)
- > Distributors



Strong points

- > Positive break indication
- > Direct or external operation
- > Compact footprint
- > DIN-rail or base mounting
- > Wide range of accessories
- > Up to 8 pole or 4 pole MTS

Conformity to standards

- > UL 508, CSA-C22.2 No. 14, Guide NLRV, File E173959
- > CSA-C22.2 No. 14, Class 3211-05, File 112964
- > IEC 60947-3



UL 508 manual motor controller “Suitable as motor disconnect”

References

Rating (A)	No. of poles	Toggle switch (direct handle included)	Rotary switch	Direct handle	External front and right side handles ⁽⁴⁾	Shaft for external handles	Switched fourth pole module	Auxiliary contacts	Terminal shrouds	Door mounting kit
16 A	3 P	2205 3000	2200 3000	Blue 2299 5012	S00 type 1-0 Black 3R, 12 1473 1111	S00/S0 type 5.9 in 150 mm 1407 0515 7.9 in 200 mm 1407 0520 12.6 in 320 mm 1407 0532 ⁽²⁾	1 P 2200 1000	M type 1 AC NO + NC 2299 0001 1 AC 2 NC 2299 0011	1 P 2294 1005 ⁽³⁾ 3 P 2294 3005 ⁽³⁾	2299 3409
20 A	3 P	2205 3001	2200 3001		Red/Yellow 3R, 12 ⁽¹⁾ 1474 1111		1 P 2200 1001			
25 A	3 P	2205 3002	2200 3002		Black 4, 4X ⁽¹⁾ 147D 1111		1 P 2200 1002			
32 A	3 P	2205 3003	2200 3003		Red/Yellow 4, 4X ⁽¹⁾ 147E 1111		1 P 2200 1003			
40 A	3 P	2205 3004	2200 3004		S0 type 1-0 Black 1, 3R, 12 ⁽¹⁾ 1483 1111		1 P 2200 1004			
63 A	3 P	2205 3006	2200 3006		Red/Yellow 1, 3R, 12 ⁽¹⁾ 1484 1111		1 P 2200 1006			
80 A	3 P	2205 3008	2200 3008		Black 4, 4X ⁽¹⁾ 148D 1111		1 P 2200 1008			
100 A CD	3 P		2200 3009		Red/Yellow 4, 4X ⁽¹⁾ 148E 1111		1 P 2200 1009			

(1) Common accessories - more available on next pages.

(2) Please order the shaft guide: 1419 0000 with the shaft.

(3) Top and bottom.

(4) There is no door interlocking when the switch is fitted on the side of the enclosure.

UL 508 non-metallic polycarbonate 4, 4X enclosed SIRCO M



Function

Enclosed SIRCO M switches allow safe control and disconnection of any motor application.

General characteristics

- Grey enclosure with red handle.
- Equipped with a 3 pole SIRCO M UL 508.
- 1 removable ground terminal.
- Possibility of adding 1 power pole and 1 auxiliary contact.
- Nema/UL type 1, 3R, 12, 4, 4X.

Conformity to standards⁽¹⁾

- > UL 508, CSA-C22.2 No. 14 Guide NLRV, File E173959
- > CSA-C22.2 No. 14, Class 3211-05, File 112964
- > IEC 60947-3



(1) Product reference on request.

SIRCO M UL 508

Non-fusible disconnect switches standards UL and CSA
from 16 to 100 A

Accessories

Direct operation handle

Rating (A)	Handle color	Handle type	Reference
16 ... 100 CD	Blue	M00	2299 5012

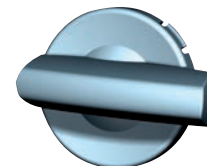

M00 handle

access_277_a_2_cat

External operation handle

Use

The handle locking function prevents the user from opening the door of the enclosure when the switch is in the "ON" position (only if the handle is fitted on the door).

No interlock in the "OFF" position for S00 and S0 handles.

Opening the door when the switch is in the "ON" position is possible by defeating the interlocking function with the use of a tool (authorized persons only). The interlocking function is restored when the door is closed. The handle is padlockable with 3 padlocks.



S00 handle

access_264_a_2_cat

Front and right side handles I - 0

Rating (A)	Handle color	Handle type	Nema / UL type	Reference
16 ... 100 CD	Black	S00	3R, 12	1473 1111
16 ... 100 CD	Red/Yellow	S00	3R, 12	1474 1111
16 ... 100 CD	Black	S00	4, 4X	147D 1111
16 ... 100 CD	Red/Yellow	S00	4, 4X	147E 1111
16 ... 100 CD	Black	S0	1, 3R, 12	1483 1111
16 ... 100 CD	Red/Yellow	S0	1, 3R, 12	1484 1111
16 ... 100 CD	Black	S0	4, 4X	148D 1111
16 ... 100 CD	Red/Yellow	S0	4, 4X	148E 1111
16 ... 100 CD	Black	S01 ⁽¹⁾	3R, 12	140F 2111
16 ... 100 CD	Red/Yellow	S01 ⁽¹⁾	3R, 12	140G 2111
16 ... 100 CD	Black	S01 ⁽¹⁾	4, 4X	140D 2111
16 ... 100 CD	Red/Yellow	S01 ⁽¹⁾	4, 4X	140E 2111

(1) Not compatible with door mounting kit.

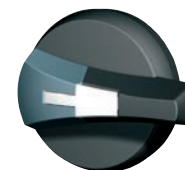

S0 handle

access_279_a_2_cat



S01 handle

access_304_a_2_cat

Front handle for heavy duty I - 0 with metallic lever

Rating (A)	Handle color	Handle type	Nema / UL type	Reference
16 ... 100 CD	Black	S01	4, 4X	140D 2911
16 ... 100 CD	Red/Yellow	S01	4, 4X	140E 2911

Front handle for transfer switches I - 0 - II

Rating (A)	Handle color	Handle type	Nema / UL type	Reference
16 ... 100 CD	Black	S00	4, 4X	1473 1113⁽¹⁾

(1) Not UL.

Shafts for external handle

Use

Standard lengths:

- 5.9 in / 150 mm
- 7.9 in / 200 mm
- 12.6 in / 320 mm

Other lengths: please consult us.

For 3/4 pole switches, shaft extensions for external front and side handle.

For 6/8 pole switches and SIRCO M transfer switches.



access_280_a_2_cat

For 3/4 pole

Ratg (A)	Handle type	Length		Reference
		(in)	(mm)	
16 ... 100 CD	S00/S0	5.9	150	1407 0515
16 ... 100 CD	S00/S0	7.9	200	1407 0520
16 ... 100 CD	S00/S0	12.6	320	1407 0532
16 ... 100 CD	S01	7.9	200	1404 0520
16 ... 100 CD	S01	12.6	320	1404 0532
16 ... 100 CD	S01	15.7	400	1404 0540

For 6/8 pole

Rating (A)	Handle type	Length		Reference
		(in)	(mm)	
16 ... 100 CD	S00/S0	5.9	150	1407 0515
16 ... 100 CD	S00/S0	7.9	200	1407 0520
16 ... 100 CD	S00/S0	12.6	320	1407 0532

Accessories (continued)

Shaft guide for external handle

Use

This accessory enables handle to engage extension shaft with a misalignment of up to 0.59 in/15 mm. Required for a shaft length over 12.6 in/320 mm.

Handle type	Reference
S00 and S0	1419 0000



access_280_a_2_cat

Additional pole

4th pole

Rating (A)	No. of poles	Type	Reference
16	1 P	switched	2200 1000
20	1 P	switched	2200 1001
25	1 P	switched	2200 1002
32	1 P	switched	2200 1003
40	1 P	switched	2200 1004
63	1 P	switched	2200 1006 ⁽¹⁾
80	1 P	switched	2200 1008 ⁽¹⁾
100 CD	1 P	switched	2200 1009 ⁽¹⁾

(1) Not UL.

Use

Transforms:
 - 3 pole SIRCO M non-fusible disconnect switch into a 4 pole,
 - 3 pole SIRCO M transfer switch into a 4 pole.



sircm_072_b_1_cat

Solid neutral pole

Rating (A)	No. of poles	Type	Reference
16 ... 40	1 P	unswitched	2200 5005
63 ... 100 CD	1 P	unswitched	2200 5009

Use

Transforms the 3-pole switch into a 3-pole + solid neutral.

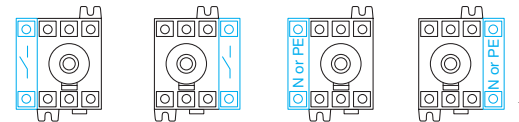

sircm_078_a_1_gp_cat

Ground module

Rating (A)	No. of poles	Type	Reference
16 ... 40	1 P	unswitched	2200 9005
63 ... 100 CD	1 P	unswitched	2200 9009

Use

Adds 1 protective ground module pole to the non-fusible disconnect switch.

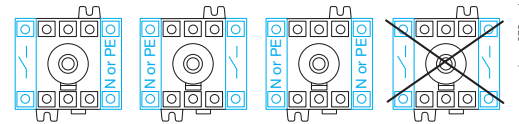

Terminal shrouds

Use

Top and bottom additional protection against direct contact with the terminals or connection parts. 1 or 3 pole are available.

Perforation on each terminal cover enables remote thermographic inspection without dismantling.

Rating (A)	No. of poles	Position	Reference
16 ... 40	1 P	top and bottom	2294 1005
16 ... 40	3 P	top and bottom	2294 3005
63 ... 100 CD	1 P	top and bottom	2294 1009
63 ... 100 CD	3 P	top and bottom	2294 3009



sircm_048_a_1_cat

SIRCO M UL 508

Non-fusible disconnect switches standards UL and CSA
from 16 to 100 A

M type Auxiliary Contacts

Use

Pre-break and signaling of positions 0 and I by NO+NC or 2 NO Auxiliary Contacts.
They can be mounted on the left or on the right side of the device.

Max 4 Auxiliary Contacts per product (2 modules).

Characteristics

A300.

Rating (A)	No. of AC	AC type	Reference
16 ... 100 CD	1 AC	NO + NC	2299 0001
16 ... 100 CD	1 AC	2 NO	2299 0011

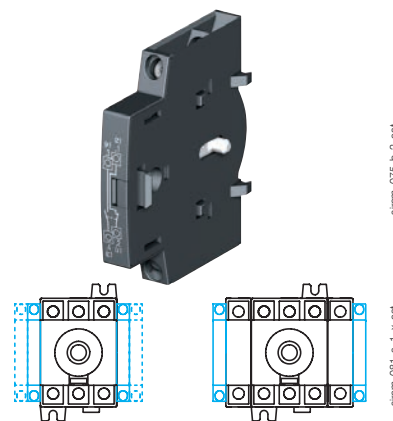

Auxiliary contacts configurations for SIRCO M

Conversion kit

Use

These accessories enable the assembly of 2 switches in order to achieve:

- 6 or 8 pole switches
- 3 or 4 pole open or close transition transfer switches.

Rating (A)	Type	Reference
16 ... 100 CD	Non-fusible disconnect switches 6/8 pole	2269 6009
16 ... 100 CD	Transfer switch 3/4 pole (I - 0 - II)	2209 6009
16 ... 100 CD	Transfer switch 3/4 pole (I - I+II - II)	2299 6009 ⁽¹⁾

(1) Not UL.



Conversion kit for 6 or 8 pole non-fusible disconnect switches



Conversion kit for 3 and 4-pole transfer switches (I - 0 - II) or (I - I+II - II)



Door mounting kit

Use

This kit enables direct mounting of the switch on the panel door or on the right or left side of the panel with S00 and S0 handles.

The S0 and S00 external handles are quick and easy to install due to an internal locking nut mounted on the inside of the enclosure.

Rating (A)	No. of poles	Reference
16 ... 100 CD	3/4 P	2299 3409

Not compatible with S01 handle.
No need of external shaft.

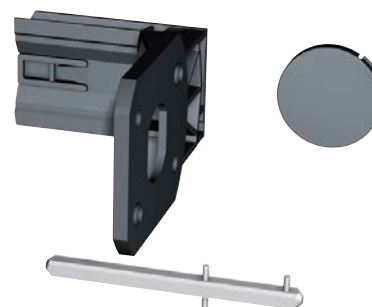

Characteristics

Characteristics according to UL 508 and CSA-C22.2 No. 14

General use rating (A)	16 A	20 A	25 A	32 A	40 A	63 A	80 A	100 A CD
Short circuit rating at 600 VAC (kA)	65	65	65	65	10/65	50/65	50/65	50/65
Type of fuse	J	J	J	J	J	J	J	J
Max fuse rating (A)	30	30	30	30	60/30	100/60	100/60	100/60
Max. motor hp/FLA 3 ph motor max.								
208 VAC	3/0.6	5/16.7	7.5/24.2	7.5/24.2	7.5/24.2	15/46.2	15/46.2	15/46.2
220-240 VAC	5/15.2	5/15.2	7.5/22	7.5/22	7.5/22	20/54	20/54	20/54
440-480 VAC	10/14	10/14	15/21	20/27	20/27	40/52	40/52	40/52
600 VAC	10/11	15/17	20/22	25/27	25/27	40/41	40/41	40/41
Connection terminals								
Solid - 1 wire	#14 - #10	#14 - #10	#14 - #10	#14 - #10	#14 - #10	#14 - #10	#14 - #10	#8 - #2
Solid - 2 wires	2 x #12	2 x #12	2 x #12	2 x #12	2 x #12	2 x #12	2 x #12	2 x - #12
Stranded - 1 wire	#14 - #4	#14 - #4	#14 - #4	#14 - #4	#14 - #4	#14 - #1	#14 - #1	#14 - #10
Stranded - 2 wires	2 x (#14 - #12)	2 x (#14 - #12)	2 x (#14 - #12)	2 x (#14 - #12)	2 x (#14 - #12)	2 x (#10 - #6)	2 x (#10 - #6)	2 x - (#10 - #6)
Auxiliary contacts								
Electrical characteristics	A300	A300	A300	A300	A300	A300	A300	A300
Mechanical characteristics								
Endurance (number of operating cycles)	10,000	10,000	10,000	10,000	10,000	10,000	10,000	10,000
Operating torque (lbs.in/Nm)	7/0.8	7/0.8	7/0.8	7/0.8	7/0.8	8.9/1	8.9/1	8.9/1

Characteristics according to IEC 60947-3

Thermal current I_{th} (40°C)	16 A	20 A	25 A	32 A	40 A	63 A	80 A	100 A CD
Rated insulation voltage U_i (V)	800	800	800	800	800	800	800	800
Rated impulse withstand voltage U_{imp} (kV)	8	8	8	8	8	8	8	8
Rated operational currents I_e (A)								
Rated voltage	Utilization	A/B ⁽¹⁾	A/B ⁽¹⁾	A/B ⁽¹⁾	A/B ⁽¹⁾	A/B ⁽¹⁾	A/B ⁽¹⁾	A/B ⁽¹⁾
415 VAC	AC-23 A/AC-23 B	16/16	20/20	25/25	32/32	40/40	63/63	80/80
500 VAC	AC-22 A/AC-22 B	16/16	20/20	25/25	32/32	40/40	63/63	-
500 VAC	AC-23 A/AC-23 B	16/16	20/20	25/25	25/25	25/25	63/63	63/63
690 VAC	AC-21 A/AC-21 B	16/16	20/20	25/25	32/32	40/40	63/63	80/80
690 VAC	AC-22 A/AC-22 B	16/16	20/20	25/25	32/32	32/40	40/63	63/80
690 VAC	AC-23 A/AC-23 B	16/16	20/20	25/25	25/25	25/25	40/40	40/40
Operational power in AC-23 (kW)								
At 400 VAC without prebreaking AC in AC-23 (kW) ⁽¹⁾⁽²⁾	7.5	9	11	15	18.5	30	37	-
At 500 VAC without prebreaking AC in AC-23 (kW) ⁽¹⁾⁽²⁾	7.5	9	11	15	15	30	37	-
At 690 VAC without prebreaking AC in AC-23 (kW) ⁽¹⁾⁽²⁾	7.5	11	15	18.5	18.5	30	37	-
Fuse protected short-circuit withstand (kA rms prospective)								
Prospective short-circuit current (kA rms) ⁽³⁾	50	50	50	50	50	50	50	25
Associated fuse rating (A) ⁽³⁾	16	20	25	32	40	63	80	100
Overload capacity (U_e 415 VAC)								
Rated short-time withstand current 0.3 s. I_{cw} (kA rms) ⁽³⁾	2.5	2.5	2.5	2.5	2.5	3	3	1.5
Rated short-circuit making capacity I_{cm} (kA peak) ⁽³⁾	6	6	6	6	6	9	9	2.1
Connection								
Minimum Cu cable cross section (mm ²)	1.5	1.5	1.5	1.5	1.5	2.5	2.5	2.5
Maximum Cu cable section (mm ²)	16	16	16	16	16	35	35	35
Tightening torque min/ max (Nm)	2/2.2	2/2.2	2/2.2	2/2.2	2/2.2	3.5/3.85	3.5/3.85	3.5/3.85

(1) A/B: Category with index A = frequent operation - Category with index B = infrequent operation.

(2) The power value is given for information only, the current values vary from one manufacturer to another.

(3) For a rated operating voltage $U_e = 400$ VAC.

SIRCO M UL 508

Non-fusible disconnect switches standards UL and CSA
from 16 to 100 A

Dimensions (in/mm)

16 to 100 A

Toggle operation

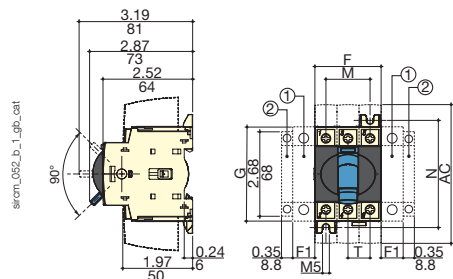

Direct operation with handle

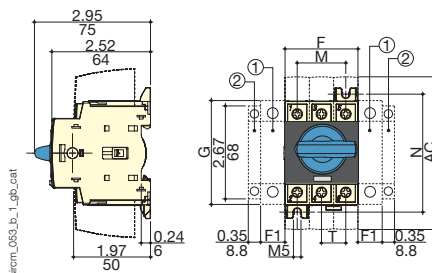

1. Position for 1 switched fourth pole module (1 per device max.) or 1 unswitched neutral pole or 1 protective ground module or 1 auxiliary contact.
2. Position for 1 auxiliary contact only.

Note: Maximum of 4 additional blocks.

External front handle

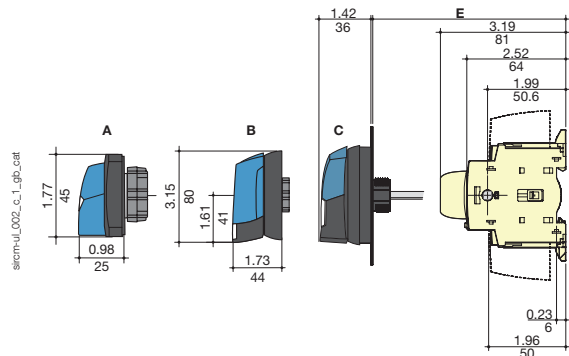

External side handle

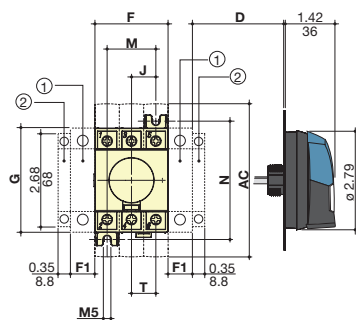

1. Position for 1 switched fourth pole module (1 per device max.) or 1 unswitched neutral pole or 1 ground module or 1 auxiliary contact.
2. Position for 1 auxiliary contact only.

Note: Maximum of 4 additional blocks.

Rating (A)	Units	Overall dimensions				Terminal shrouds		Switch body			Switch mounting		Connection
		D min	D max	E min	E max	AC	F	F1	G	J	M	N	T
16 ... 40	in	1.18	9.25	3.94	14.64	4.33	1.77	0.59	2.67	0.59	1.18	2.95	0.59
	mm	30	235	100	372	110	45	15	68	15	30	75	15
63 ... 100 CD	in	1.18	9.25	3.93	14.64	4.33	2.06	0.69	2.99	0.69	1.38	3.35	0.69
	mm	30	235	100	372	110	52.5	17.5	76	17.5	35	85	17.5

Direct front handle for 6/8-pole non-fusible disconnect switches
or 3/4-pole transfer switches

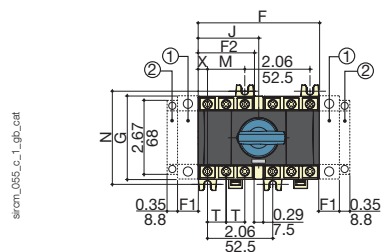

External front handle for 6/8-pole non-fusible disconnect switches
or 3/4-pole transfer switches

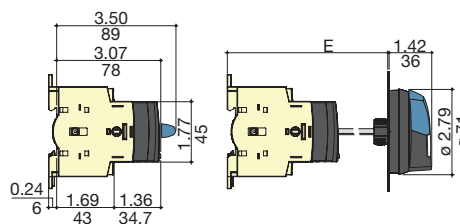

1. Position for 1 switched fourth pole module (1 per device max.) or 1 unswitched neutral pole or 1 ground module or 1 auxiliary contact.
2. Position for 1 auxiliary contact only.

Note: Maximum of 4 additional blocks.

Rating (A)	Units	Overall dimensions				Switch body				Switch mounting		Connection	
		E min	E max	F	F1	F2	G	J	M	N	T	X	
16 ... 40	in	4.13	14.64	3.83	0.59	1.77	2.67	1.92	1.18	2.95	0.59	0.29	
	mm	105	372	97.5	15	45	68	48.75	30	75	15	7.5	
63 ... 100 CD	in	4.13	14.65	4.13	0.69	2.06	2.99	2.06	1.38	3.35	0.69	0.34	
	mm	105	372	105	17.5	52.5	76	52.5	35	85	17.5	8.75	

External handle dimensions (in/mm)

16 to 100 A

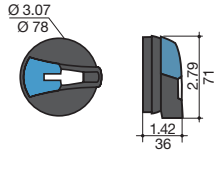
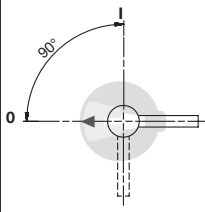
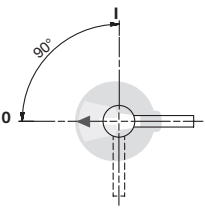
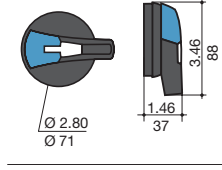
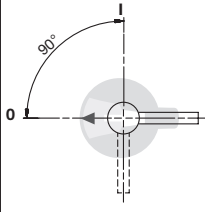
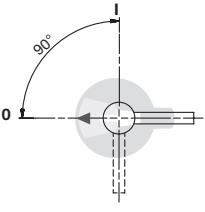
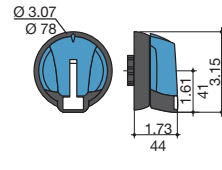
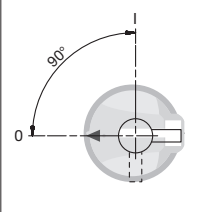
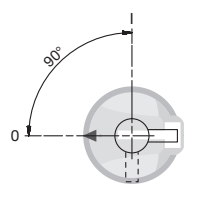
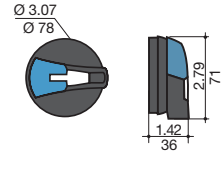
Handle type	Front operation Direction of operation	Side operation Direction of operation	Door drilling
S00 type 			Door drilling With 4 fixing screws: Ø 1.22, Ø 31, 1.57, 40, 2 Ø 0.28, 2 Ø 7, 1.57, 40. With fixing nut: 0.12, 3, 0.53, 13.5, Ø 0.89, Ø 22.5.
S0 type 			Door drilling With 4 fixing screws: Ø 1.22, Ø 31, 1.57, 40, 2 Ø 0.28, 2 Ø 7, 1.57, 40. With fixing nut: 0.12, 3, 0.53, 13.5, Ø 0.89, Ø 22.5.
S01 type 			Door drilling With 4 fixing screws: Ø 1.46, Ø 37, 1.57, 40, 4 Ø 7, 4 Ø 0.28, 1.10, 28.
S00 type Transfer switches 	Front operation Direction of operation: 0 or I-II, 90°, 90°.		Door drilling With 4 fixing screws: Ø 1.45, Ø 37, 1.10, 28, 4 Ø 0.27, 4 Ø 7. With fixing nut: 0.53, 13.5, Ø 0.88, Ø 22.5, 0.12, 3.

pogn_009_a_1_us_cat

pogn_060_a_1_us_cat

pogn_018_a_1_gb_cat

pogn_070_a_1_gb_cat

SIRCO M UL 98

Non-fusible disconnect switches standards UL and CSA
from 30 to 100 A



Rotary switch
SIRCO M 3 x 100 A

Function

SIRCO M UL 98 are compact non-fusible disconnect switches that make and break under on and off load conditions and provide safe isolation.

These switches are extremely durable and are tested and approved for use in the most demanding applications.

General characteristics

- Positive break indication.
- Touch safe.
- DIN rail or back plate-mounted.
- Direct or external operation handle.

Specific characteristics

- Contact point technology.

References

UL 98 non-fusible disconnect switches

Rating (A)	No. of poles	Switch body	Direct handle	External front and right side handles	Shafts for external front and side handles	Switched fourth pole module	Unswitched neutral pole	Ground module	Auxiliary contacts	Terminal shrouds
30 A	3 P	2201 3003		S0 type 1 - 0	5.9 in 150 mm 1407 0515	1 P 2201 1003				
60 A	3 P	2201 3006	Blue 2299 5032	Black 4, 4X 148D 1111	7.9 in 200 mm 1407 0520	1 P 2201 1006	1 P 2200 5011	1 P 2200 9011	M type 1 AC NO + NC 2299 0001	1 P 2294 1011 ⁽³⁾
100 A	3 P	2200 3010		Red/Yellow 4, 4X 148E 1111	12.6 in 320 mm 1407 0532 ⁽²⁾	1 P 2200 1010			M type 1 AC 2 NC 2299 0011	3 P 2294 3016 ⁽³⁾

(1) Common accessories - more available on next pages.

(2) Shaft guide reference 14190000, is required for shaft length over 12.6 in / 320 mm.

(3) Top and bottom.

The solution for

- > OEM/Machine Builders
- > Industrial Control Panel Manufacturers (UL 508A)
- > Switchboard Manufacturers (UL 891)
- > Distributors



Strong points

- > Positive break indication
- > Touch safe
- > DIN rail or back plate-mounted
- > Direct or external operation handle
- > Contact point technology

Conformity to standards

- > UL 98, CSA-C22.2 No. 4, Guide WHTY, File E201138
- > CSA-C22.2 No. 4, Class 4651-02, File 112964
- > IEC 60947-3



Accessories

Direct operation handle

Rating (A)	Handle color	Handle type	Reference
30 ... 100	Blue	M01	2299 5032

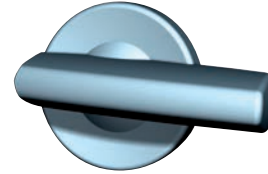

accses_285_a_2_cat

M01 handle

External operation handle

Use

The handle locking function prevents the user from opening the door of the enclosure when the switch is in the "ON" position (only if the handle is fitted on the door).

No interlock in the "OFF" position for S0 handles.

Opening the door when the switch is in the "ON" position is possible by defeating the interlocking function with the use of a tool (authorized persons only). The interlocking function is restored when the door is closed. The handle is padlockable with 3 padlocks.

Front and right side handles I - 0

Rating (A)	Handle color	Handle type	Nema/UL type	Reference
30 ... 100	Black	S0	1, 3R, 12	1483 1111
30 ... 100	Red/Yellow	S0	1, 3R, 12	1484 1111
30 ... 100	Black	S0	4, 4X	148D 1111
30 ... 100	Red/Yellow	S0	4, 4X	148E 1111
30 ... 100	Black	S01	3R, 12	140F 2111
30 ... 100	Red/Yellow	S01	3R, 12	140G 2111
30 ... 100	Black	S01	4, 4X	140D 2111
30 ... 100	Red/Yellow	S01	4, 4X	140E 2111

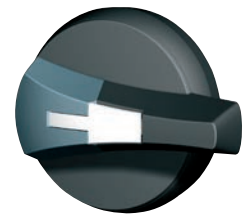

accses_279_a_2_cat

S0 handle



accses_304_a_2_cat

S01 handle

Front handle for heavy duty I - 0 with metallic lever

Rating (A)	Handle color	Handle type	Nema / UL type	Reference
16 ... 100 CD	Black	S01	4, 4X	140D 2911
16 ... 100 CD	Red / Yellow	S01	4, 4X	140E 2911

Shafts for external handle

Use

Standard lengths:

- 5.9 in / 150 mm,
- 7.9 in / 200 mm,
- 12.6 in / 320 mm,
- 15.7 in / 400 mm.

Other lengths: please consult us.

For 3/4 pole switches, shaft extensions for external front and side handle.



accses_280_a_2_cat

For 3/4 pole

Rating (A)	Handle type	Length		Reference
		(inches)	(mm)	
30 ... 100	S0	5.9	150	1407 0515
30 ... 100	S0	7.9	200	1407 0520
30 ... 100	S0	12.6	320	1407 0532
30 ... 100	S01	7.9	200	1404 0520
30 ... 100	S01	12.6	320	1404 0532
30 ... 100	S01	15.7	400	1404 0540

SIRCO M UL 98

Non-fusible disconnect switches
from 30 to 100 A

Accessories (continued)

Shaft guide for external handle

Use

This accessory makes shaft introduction easier with up to 0.59 in / 15 mm misalignment.
Required for a shaft length over 12.6 in / 320 mm.

Handle type	Reference
S0	1419 0000



access_260_a_2_cat

Additional pole for SIRCO M

4th pole

Rating (A)	No. of poles	Type	Reference
30	1 P	switched	2201 1003
60	1 P	switched	2201 1006
100	1 P	switched	2200 1010

Use

Adding one or two additional poles transforms a non-fusible disconnect switch from 3 poles to 4 poles.



siem_072_b_1_cat

Solid neutral pole

Rating (A)	No. of poles	Type	Reference
30 ... 100	1 P	unswitched	2200 5011

Use

Transforms the 3-pole switch into a 3-pole + solid neutral.

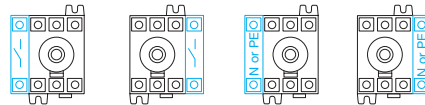

siem_078_a_1_cat

Ground module

Rating (A)	No. of poles	Type	Reference
30 ... 100	1 P	unswitched	2200 9011

Use

Adds 1 ground module pole to the switch-disconnector.

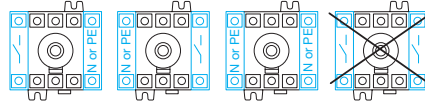

Terminal shrouds

Use

Top and bottom additional protection against direct contact with the terminals or connection parts. 1 or 3 pole are available.

Perforation on each terminal cover enables remote thermographic inspection without dismantling.



siem_049_a_1_cat

Rating (A)	No. of poles	Position	Reference
30 ... 100	1 P	top and bottom	2294 1011
30 ... 100	3 P	top and bottom	2294 3016

M type auxiliary contacts

Use

Pre-break and signaling of positions 0 and I by NO+NC or 2 NO auxiliary contacts.

Max 4 auxiliary contacts (2 modules).

They can be mounted on the left or on the right side of the switch.

Characteristics

A300.

Rating (A)	No. of AC	AC type	Reference
30 ... 100	1 AC	NO + NC	2299 0001
30 ... 100	1 AC	2 NO	2299 0011



siem_075_b_2_cat

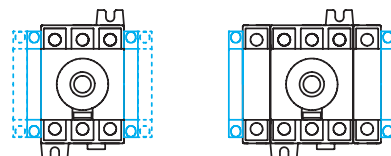

siem_081_a_1_cat

Auxiliary contacts configurations for SIRCO M

Characteristics

Characteristics according to UL 98 and CSA-C22.2 No. 4

General use rating	30 A	60 A	100 A
Short-circuit rating at 480 VAC (kA)	100	100	100
Short-circuit rating at 600 VAC (kA)	100	100	25
Type of fuse	J	J	J
Max fuse rating (A)	30	60	100
Max. motor hp / FLA 3 ph motor max.			
220-240 VAC	10/28	20/54	20/54
440-480 VAC	20/27	40/52	50/65
600 VAC	25/27	50/52	50/52
Max. motor hp / FLA 1 ph motor max.			
120 VAC	2/24	3/34	5/56
240 VAC	5/28	10/50	10/50
Connection terminals			
Solid - 1 wire	#10	#10	#10
Stranded - 1 wire	#10 - 2/0	#10 - 2/0	#10 - 2/0
Solid - 2 wires	2 x #10	2 x #10	2 x #10
Stranded - 2 wires	2 x (#10 - #1)	2 x (#10 - #1)	2 x (#10 - #1)
Mechanical characteristics			
Endurance (number of operating cycles)	10000	10000	10000
Operating torque (lbs.in/Nm)	12.4 / 1.4	12.4 / 1.4	12.4 / 1.4
Auxiliary Contacts			
Electrical Characteristics	A300	A300	A300

Characteristics according to IEC 60647-3

Thermal current I_{th} at 40°C (A)	30 A	60 A	100 A	
Rated insulation voltage U_i (V)	800	800	800	
Rated impulse withstand voltage U_{imp} (kV)	8	8	8	
Rated operational currents I_g (A)				
Rated voltage	Utilization category	A ⁽¹⁾	A ⁽¹⁾	A ⁽¹⁾
400 VAC	AC-22 A	32	63	100
400 VAC	AC-23 A	32	63	100
690 VAC	AC-22 A	32	63	80
690 VAC	AC-23 A	32	63	63
Operational power in AC-23 (kW)				
At 400 VAC without prebreak AC in AC23 (kW) ⁽²⁾⁽³⁾	15	30	45	
At 500VAC without prebreak AC in AC23 (kW) ⁽²⁾⁽³⁾	15	30	45	
At 690VAC without prebreak AC in AC23 (kW) ⁽²⁾⁽³⁾	18.5	30	45	
Overload capacity (U_g 415 VAC)				
Rated short-circuit making capacity I_{cm} (kA peak) ⁽⁴⁾	12	12	12	
Connection				
Min. connection section/ (mm ²)	2.5	2.5	10	
Max. connection section/ (mm ²)	70	70	70	

(1) Category with index A = frequent operation.

(2) A/B: Category with index A = frequent operation - Category with index B = infrequent operation.

(3) The power value is given for information only, the current values vary from one manufacturer to another.

(4) For a rated operating voltage $U_g = 400$ VAC.

SIRCO M UL 98

Non-fusible disconnect switches
from 30 to 100 A

Dimensions (in/mm)

30 to 100 A

Direct operation with handle

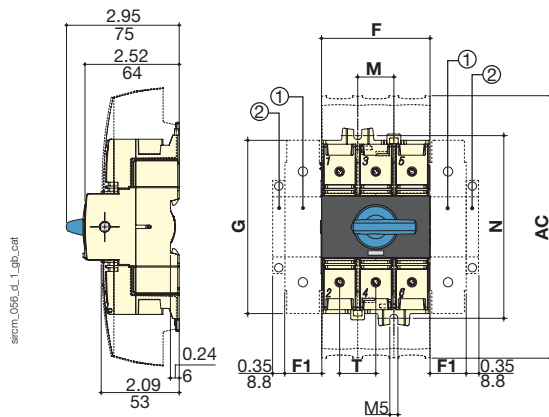

1. Location for: 1 switched fourth pole module (1 per device max.) or 1 unswitched neutral pole or 1 protective earth module or 1 auxiliary contact.
2. Position for 1 auxiliary contact module only.
Note: max 2 additional blocks.

External front operation

External side operation

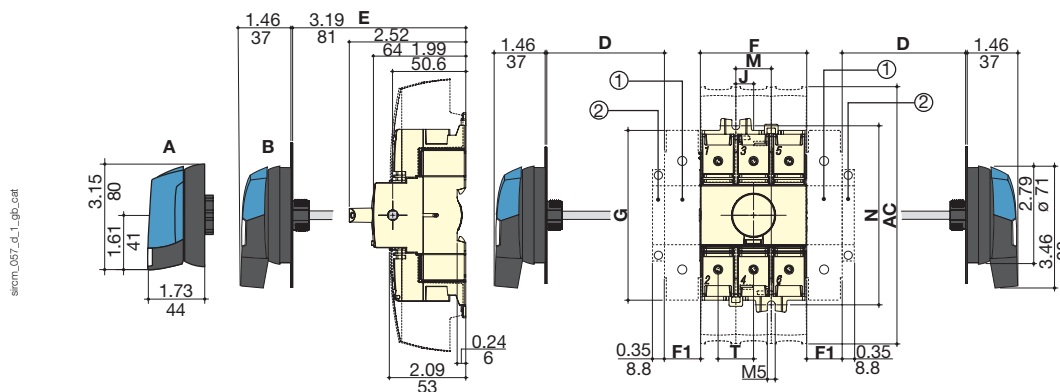

1. Location for: 1 switched fourth pole module (1 per device max.) or 1 unswitched neutral pole or 1 protective earth module or 1 auxiliary contact.

2. Position for 1 auxiliary contact module only.
Note: max 2 additional blocks.

A. S01 handle
B. S00 handle

Rating (A) / Frame size		Overall dimensions				Terminal shrouds		Switch body			Switch mounting		Connection
		D min	D max	E min	E max	AC	F	F1	G	J	M	N	T
30 ... 100 / M3	mm	30	201	100	372	189	78	26	124.6	13	26	131.4	26
	in	1.18	7.93	3.94	14.64	7.44	3.07	1.02	4.90	0.51	1.02	5.17	1.02

External handle dimensions (in/mm)

30 to 100 A

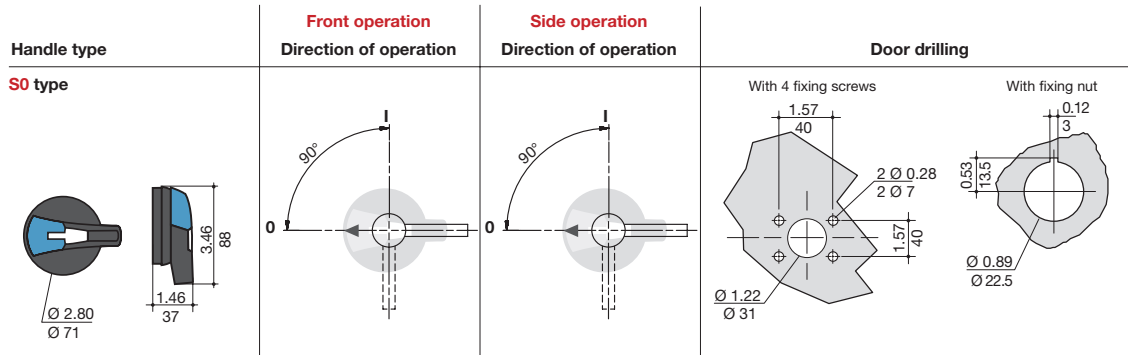

poign_060_a_1_Lus_cat

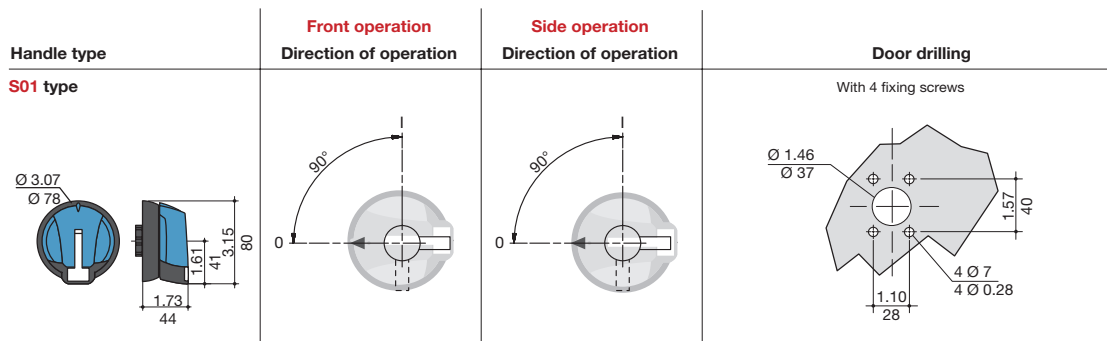

poign_016_a_1_Lus_cat

SIRCO UL 98

Non-fusible switches standards UL and CSA
100 to 1200 A



SIRCO
3 x 600 A



SIRCO
3 x 200 A

Function

SIRCO non-fusible disconnect switches are heavy duty switches that break and make power circuits on and off load and provide safety isolation.

These switches are extremely durable and are tested and approved for use in the most demanding applications.

General characteristics

- Positive break indication.
- Fully visualized disconnection.
- High thermal and dynamic withstand.
- Severe utilization categories.
- High electrical and mechanical endurance.

UL 508A painted steel NEMA 3R, 12 enclosed SIRCO UL 98



Function

Enclosed SIRCO UL 98 allow safe disconnection of power sources.

General Characteristics

- Painted steel enclosure with red handle.
- Fitted with a heavy duty handle that has a metallic padlock hasp.
- Equipped with a 3 pole SIRCO UL 98 switch.
- Possibility of adding unswitched neutral pole auxiliary contacts, and terminal screens.
- Nema 3R, 12 up to 1200 A.

The solution for

- > OEM/Machine Builders
- > Industrial Control Panels Manufacturers (UL 508A)
- > Switchboard Manufacturers (UL 891)
- > AC Combiner Builders
- > Distributors



Strong points

- > Reliability
- > Safety of property and personnel
- > Simplicity
- > Easy assembling

Conformity to standards⁽¹⁾

- > UL 98, CSA-C22.2 No. 4, Guide WHTY, File E201138
- > CSA-C22.2 No. 4, Class 4651-02, File 112964
- > IEC 60947-3



⁽¹⁾ Product reference on request.

Customized solutions

- > Please consult us

Enclosed Disconnect Standards

- > cULus 508A
- > UL 98, Guide WHTY, File E201138
- > CSA 22.2 No. 4, Class 4652-04, File 112964
- > IEC 60947-3



References

Rating (A)	No. of poles	Switch body	Direct handle	External handle	Shaft for external handle	Auxiliary contacts	Terminal protection screens	Terminal Lugs kits				
100 A	3 P	2700 3011	Black 2699 5052	S2 type Black 1, 3R, 12 142F 2111 ⁽¹⁾	7.9 in 200 mm 1400 1020	1 st contact NO/NC 2799 0021 2 nd contact NO/NC 2799 0022	3 P 2798 3021 ⁽²⁾	3 P 3954 3020 ⁽⁴⁾				
	4 P	2700 4011		Red/Yellow 1, 3R, 12 142G 2111 ⁽¹⁾			3 P 2798 8021 ⁽³⁾		4 P 3954 4020 ⁽⁴⁾			
200 A	3 P	2700 3021		Black 3799 6012	Black 4, 4X 142D 2111 ⁽¹⁾		12.6 in 320 mm 1400 1032	3 P 2798 3041 ⁽²⁾	3 P 3954 3040 ⁽⁴⁾			
	4 P	2700 4021			Red/Yellow 4, 4X 142E 2111 ⁽¹⁾			3 P 2798 8041 ⁽³⁾		4 P 3954 4040 ⁽⁴⁾		
400 A	3 P	2700 3041			Black 3799 6012		Black 4, 4X 143D 3111 ⁽¹⁾	7.9 in 200 mm 1401 1520	3 P 2798 3120 ⁽⁴⁾	3 P 3954 3120		
	4 P	2700 4041					Red/Yellow 4, 4X 143E 3111 ⁽¹⁾		4 P 2798 4120 ⁽⁴⁾		4 P 3954 4120	
600 A	3 P	2700 3060					Black 3799 6012	Black 4, 4X 143D 3111 ⁽¹⁾	12.6 in 320 mm 1401 1532	3 P 2798 3060 ⁽⁴⁾	3 P 3954 3060	
	4 P	2700 4060						Red/Yellow 4, 4X 143E 3111 ⁽¹⁾		4 P 2798 4060 ⁽⁴⁾		4 P 3954 4060
800 A	3 P	2700 3080						Black 3799 6012	Black 4, 4X 143D 3111 ⁽¹⁾	15.7 in 400 mm 1401 1540	3 P 2798 3120 ⁽⁴⁾	3 P 3954 3120
	4 P	2700 4080							Red/Yellow 4, 4X 143E 3111 ⁽¹⁾		4 P 2798 4120 ⁽⁴⁾	
1000 A	3 P	2700 3100	Black 3799 6012			Black 4, 4X 143D 3111 ⁽¹⁾			15.7 in 400 mm 1401 1540	3 P 2798 3120 ⁽⁴⁾	3 P 3954 3120	
	4 P	2700 4100				Red/Yellow 4, 4X 143E 3111 ⁽¹⁾				4 P 2798 4120 ⁽⁴⁾		4 P 3954 4120
1200 A	3 P	2700 3120		Black 3799 6012		Black 4, 4X 143D 3111 ⁽¹⁾			15.7 in 400 mm 1401 1540	3 P 2798 3120 ⁽⁴⁾	3 P 3954 3120	
	4 P	2700 4120				Red/Yellow 4, 4X 143E 3111 ⁽¹⁾				4 P 2798 4120 ⁽⁴⁾		4 P 3954 4120

Common accessories - more available on next pages

- (1) Defeatable handle.
- (2) Top.
- (3) Bottom.
- (4) Top or bottom.
- (5) Max. 4 ACs.

Accessories

Direct operation handle

Rating (A)	Color	Handle type	Reference
100 ... 400	Black	B	2699 5052
600 ... 1200	Black	H	3799 6012



H type handle

B type handle

SIRCO UL 98

Non-fusible disconnect switches

100 to 1200 A

Accessories (continued)

External operation handle

Use

The interlocking function of the front external handle prevents the user from opening the door of the enclosure when the switch is in the "ON" position or when the switch is padlocked in the "OFF" position.

Opening the door when the switch is in the "ON" position is possible by defeating the interlocking function with the use of a tool (authorized persons only). The interlocking function is restored when the door is closed.

Front handle I - 0

Rating (A)	Handle type	Color	Nema type	Reference
100 ... 400	S2	Black	1, 3R, 12	142F 2111
100 ... 400	S2	Red/Yellow	1, 3R, 12	142G 2111
100 ... 400	S2	Black	4, 4X	142D 2111
100 ... 400	S2	Red/Yellow	4, 4X	142E 2111
600 ... 1200	S3	Black	4, 4X	143D 3111
600 ... 1200	S3	Red/Yellow	4, 4X	143E 3111
600 ... 1200	S4	Black	4, 4X	144D 3111
600 ... 1200	S4	Red/Yellow	4, 4X	144E 3111

Front handle heavy duty I - 0 with metallic lever

Rating (A)	Handle type	Color	Nema type	Reference
100 ... 400	S2	Black	4, 4X	142D 2911
100 ... 400	S2	Red/Yellow	4, 4X	142E 2911
600 ... 1200	S3	Black	4, 4X	143D 3911
600 ... 1200	S3	Red/Yellow	4, 4X	143E 3911
600 ... 1200	S4	Black	4, 4X	144D 3911
600 ... 1200	S4	Red/Yellow	4, 4X	144E 3911



Shaft for external handle

Use

Standard lengths:

- 7.9 in / 200 mm,
- 12.6 in / 320 mm,
- 15.7 in / 400 mm.

Other lengths: please consult us.

Rating (A)	Dimension X (in)	Dimension X (mm)	Handle type	Length (inches)	Length (mm)	Reference
100 ... 400	5.31 ... 10.43	135 ... 265	S2	7.9	200	1400 1020
100 ... 400	5.31 ... 15.16	135 ... 385	S2	12.6	320	1400 1032
100 ... 400	5.31 ... 18.31	135 ... 465	S2	15.7	400	1400 1040
100 ... 400	5.31 ... 22.25	135 ... 565	S2	19.7	500	1400 1050
600 ... 1200	8.70 ... 13.50	221 ... 343	S3, S4	7.9	200	1401 1520
600 ... 1200	8.70 ... 18.23	221 ... 463	S3, S4	12.6	320	1401 1532
600 ... 1200	8.70 ... 21.38	221 ... 543	S3, S4	15.7	400	1401 1540
600 ... 1200	8.70 ... 26.73	221 ... 679	S3, S4	19.7	536	1401 1554⁽¹⁾

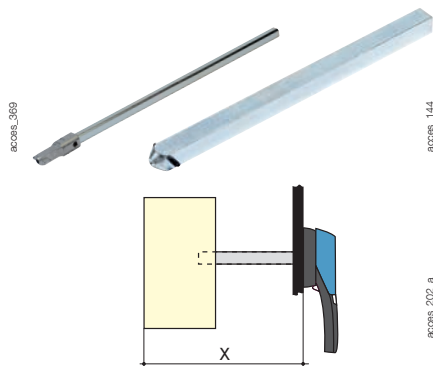

(1) UL pending, please consult us.

Alternative color S-type handle cover

Use

For single lever handles type S1, S2, S3 and double lever handle, type S4.

Other colors: please consult us.

Handle color	Pack qty	Handle type	Reference
Light grey	50	S1, S2, S3	1401 0001
Dark grey	50	S1, S2, S3	1401 0011
Light grey	50	S4	1401 0031
Dark grey	50	S4	1401 0041

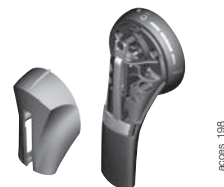

S-type handle raiser

Use

Enables S-type handles to be fitted in place of existing older style Socomec handles. Adapter can also be utilized as a spacer to increase the distance between the panel door and the handle lever.

Dimensions

Adds 0.47 in / 12 mm to the depth.

Handle color	Pack qty	Nema type	Reference
Black	10	1, 3R, 12	1493 0000



Shaft guide for external handle

Use

This accessory makes shaft introduction easier with up to 0.59 in / 15 mm misalignment.

Required for a shaft length over 12.6 in / 320 mm.

Description	Reference
Shaft guide	1429 0000



access_260

Auxiliary contacts

Use

Pre-break and color of positions 0 and I.
To have 2 NO/NC contacts per switch, please order 1st and 2nd auxiliary contacts per switch.
1st contact is mandatory to operate the 2nd one.

Electrical characteristics

A300 for 100 to 400 A.

NO/NC contact for 100 to 1200 A

These auxiliary contacts are for an application of 125-250VAC, 60Hz, general use 10A, 1A 1/2 HP.

Rating (A)	No. of AC	Reference
100 ... 1200	1 st	2799 0021
100 ... 1200	2 nd	2799 0022

Low level NO/NC contact for 100 to 1200 A

Low level auxiliary contacts are for an application of 125VAC, 60Hz, general use 1A.

Rating (A)	No. of AC	Reference
100 ... 1200	1 st	2799 0121
100 ... 1200	2 nd	2799 0122

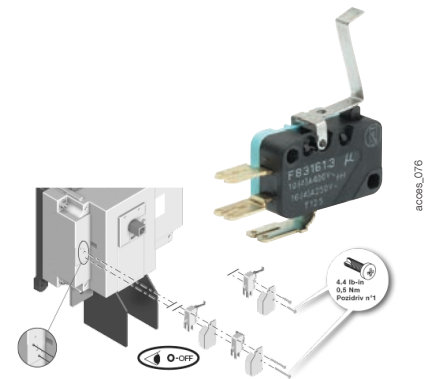

access_076

Terminal screens

Use

Top or bottom protection against direct contact with terminals or connection parts.

Rating (A)	No. of poles	Position	Reference
100 ... 200	3 P	top	2798 3021
100 ... 200	3 P	bottom	2798 8021
100 ... 200	4 P	top / bottom	2798 4021
400	3 P	top	2798 3041
400	3 P	bottom	2798 8041
400	4 P	top / bottom	2798 4041
600	3 P	bottom	2798 3060 ⁽¹⁾
600	4 P	bottom	2798 4060 ⁽¹⁾
800 ... 1200	3 P	bottom	2798 3120 ⁽¹⁾
800 ... 1200	4 P	bottom	2798 4120 ⁽¹⁾

(1) Load side screen, the line side is included with the switch.



access_079

Terminal lugs

Use

Connection of bare copper cables onto the lugs (without lugs).

Rating max (A)	Wires range	No wires per lug	Lugs per kit	Wires	Reference
100 ... 200	#6 - 300MCM	1	2	Cu / Al	3954 2020
100 ... 200	#6 - 300MCM	1	3	Cu / Al	3954 3020
100 ... 200	#6 - 300MCM	1	4	Cu / Al	3954 4020
400	#4 - 600MCM	1	2	Cu / Al	3954 2040
400	#4 - 600MCM	1	3	Cu / Al	3954 3040
400	#4 - 600MCM	1	4	Cu / Al	3954 4040
400	2x (#6 - 350MCM)	2	2	Cu / Al	3954 2041
400	2x (#6 - 350MCM)	2	3	Cu / Al	3954 3041
400	2x (#6 - 350MCM)	2	4	Cu / Al	3954 4041
600	2x (#2 - 600MCM)	2	2	Cu / Al	3954 2060
600	2x (#2 - 600MCM)	2	3	Cu / Al	3954 3060
600	2x (#2 - 600MCM)	2	4	Cu / Al	3954 4060
800 ... 1200 ⁽¹⁾	4x (#2 - 600MCM)	2	6	Cu / Al	3954 3120
800 ... 1200 ⁽¹⁾	4x (#2 - 600MCM)	2	8	Cu / Al	3954 4120

(1) Two lugs per a pole are provided to put side by side per a pole.



ul_032_a

SIRCO UL 98

Non-fusible disconnect switches

100 to 1200 A

Characteristics

Characteristics according to UL 98 and CSA-C22.2 No.4

SIRCO UL 98 - 100 to 1200 A							
General use rating (A)	100 A	200 A	400 A	600 A	800 A	1000 A	1200 A
Short circuit rating at 600 VAC (kA)	200	200	200	200	100	100	100
Type of fuse	J	J	J	J	L	L	L
Max. fuse rating (A)	100	200	400	600	800	1000	1200
Max. motor hp / FLA 3 ph motor max.							
220-240 VAC	30 / 80	75 / 196	125 / 312	200 / 480	200 / 480	200 / 480	200 / 480
440-480 VAC	75 / 96	150 / 180	250 / 302	400 / 477	500 / 590	500 / 590	500 / 590
600 VAC	100 / 99	200 / 192	350 / 336	350 / 336	500 / 472	500 / 472	500 / 472
Max. motor hp / FLA 1 ph motor max.							
220-240 VAC	10/50	10/50					
Max. motor hp / DC FLA motor max.							
125 VDC ⁽¹⁾	10 / 76	15 / 112	20 / 148	20 / 148			
250 VDC ⁽²⁾	15 / 55	15 / 55	50 / 173	50 / 173			
Connection terminals							
Min. connection section / AWG	#6	#6	2x #6 / #4	2x #2	4x #2	4x #2	4x #2
Max. connection section / AWG	300MCM	300MCM	2x 350 / 600MCM	2x 600MCM	4x 600MCM	4x 600MCM	4x 600MCM
Mechanical characteristics							
Endurance (number of operating cycles)	10000	8000	6000	6000	3500	3500	3500
Operating torque (lbs.in/Nm)	88.5/10	88.5/10	128.3/14.5	327.5/37	442.5/50	442.5/50	442.5/50
Auxiliary contacts							
Electrical characteristics	A300	A300	A300	A600	A600	A600	A600

(1) 2 pole in series.

(2) 3 pole in series.

Characteristics according to IEC 60947-3

SIRCO UL 98 - 600 to 1200 A				
Thermal current I_{th} (40°C)	600 A	800 A	1000 A	1200 A
Rated insulation voltage U_i (V)	1000	1000	1000	1000
Rated impulse withstand voltage U_{imp} (kV)	12	12	12	12
Rated operational currents I_e (A)				
Rated voltage	Utilization category	A ⁽¹⁾	A ⁽¹⁾	A ⁽¹⁾
400 VAC	AC-22 A	630	800	1000
400 VAC	AC-23 A	630	800	1000
690 VAC	AC-22 A	500	630	630
690 VAC	AC-23 A	200	400	400
Connection				
Min. Cu cable cross section (mm ²)	2 x 150	2 x 185	2 x 240	
Min. Cu busbar section (mm ²)	2 x 30 x 5	2 x 40 x 5	2 x 50 x 5	2 x 60 x 5
Operational power in AC-23 (kW)				
At 400 VAC without prebreaking AC in AC23 (kW) ⁽²⁾⁽³⁾	355	450	560	560
At 500 VAC without prebreaking AC in AC23 (kW) ⁽²⁾⁽³⁾	450	560	560	560
At 690 VAC without prebreaking AC in AC23 (kW) ⁽²⁾⁽³⁾	185	400	400	400
Overload capacity (U_e 415 VAC)				
Rated short-circuit making capacity I_{cm} (kA peak) ⁽⁴⁾	48	75	48	75

(1) Category with index A = frequent operation.

(2) A/B: Category with index A = frequent operation - Category with index B = infrequent operation.

(3) The power value is given for information only, the current values vary from one manufacturer to another.

(4) For a rated operating voltage $U_e = 400$ VAC.

Dimensions (in/mm)

100 and 200 A

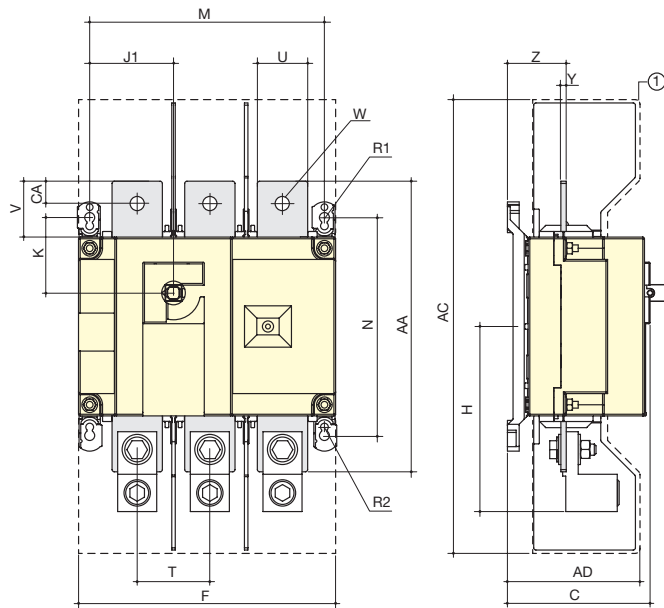

1. Terminal shrouds

sirco_ul011_a_2_x_cat

Rating (A)	Unit	Overall dimensions	Terminal shrouds		Switch body					Switch mounting					Connection								
		C	AC	AD	F 3p.	F 4p.	H	J1 3p.	J1 4p.	K	M 3p.	M 4p.	N	R1	R2	T	U	V	W	Y	Z	AA	CA
100	in	3.72	10.1	3.05	7.09	9.06	4.22	2.17	4.13	1.8	6.3	8.27	5.31	0.35	0.27	1.97	0.98	1.18	0.43	0.14	1.35	6.3	0.6
	mm	94.6	256	77.5	180	230	107	55	105	45.6	160	210	135	9	7	50	25	30	11	3.5	34.4	160	15
200	in	3.72	10.1	3.05	7.09	9.06	4.22	2.17	4.13	1.8	6.3	8.27	5.31	0.35	0.27	1.97	0.98	1.18	0.43	0.14	1.35	6.3	0.6
	mm	94.6	256	77.5	180	230	107	55	105	45.6	160	210	135	9	7	50	25	30	11	3.5	34.4	160	15

400 and 600 A

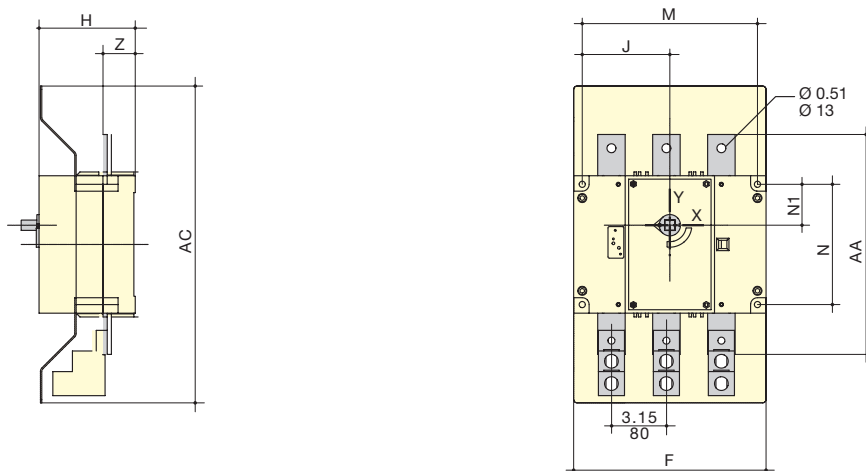

sirco_107_d_1_x_cat

Rating (A)	Unit	Terminal shrouds	Switch body				Switch mounting				Connection		
		AC	F 3p.	F 4p.	H	J 3p.	J 4p.	M 3p.	M 4p.	N	N1	AA	Z
400	in	18.12	11	14.17	5.5	5	6.59	10.04	13.19	6.88	2.34	11.81	1.85
	mm	460	280	360	140	127.5	167.5	255	335	175	59.5	300	47
600	in	18.12	11	14.17	5.5	5	6.59	10.03	13.19	6.88	2.34	12.6	1.85
	mm	460	280	360	140	127.5	167.5	255	335	175	59.5	320	47

SIRCO UL 98

Non-fusible disconnect switches
100 to 1200 A

Dimensions (in/mm) (continued)

800 to 1200 A

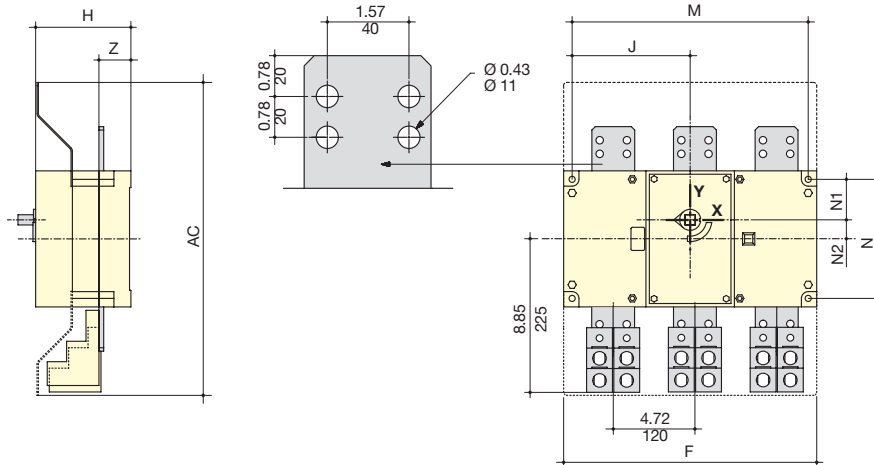

sircou228_d_1_x_cat

Rating (A)	Unit	Terminal shrouds		Switch body				Switch mounting			
		AC	F 3p.	F 4p.	H	J 3p.	J 4p.	M 3p.	M 4p.	N	N1
800	in	18.12	14.64	19.37	5.5	6.83	9.19	13.66	18.38	6.88	2.34
	mm	460	372	492	140	173.5	233.5	347	467	175	59.5
1 000	in	18.12	14.64	19.37	5.5	6.83	9.19	13.66	18.38	6.88	2.34
	mm	460	372	492	140	173.5	233.5	347	467	175	59.5
1 200	in	18.12	14.64	19.37	5.5	6.83	9.19	13.66	18.38	6.88	2.34
	mm	460	372	492	140	173.5	233.5	347	467	175	59.5

100 to 400 A

Front direct handle

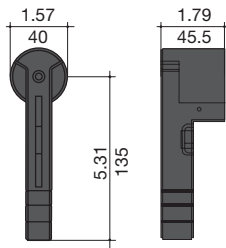

600 to 1200 A

Front direct handle

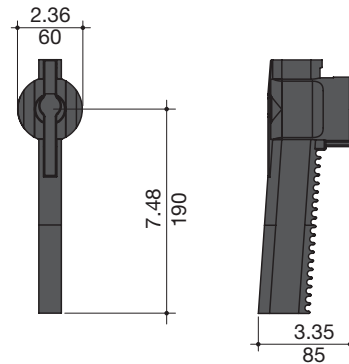

sircou027_a_1_x_cat

sircou287_b_1_x_cat

Mounting orientation

3/4 pole

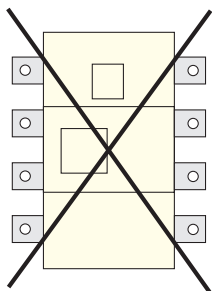

sircou028_a_1_x_cat

External handle dimensions (in/mm)

100 to 400 A

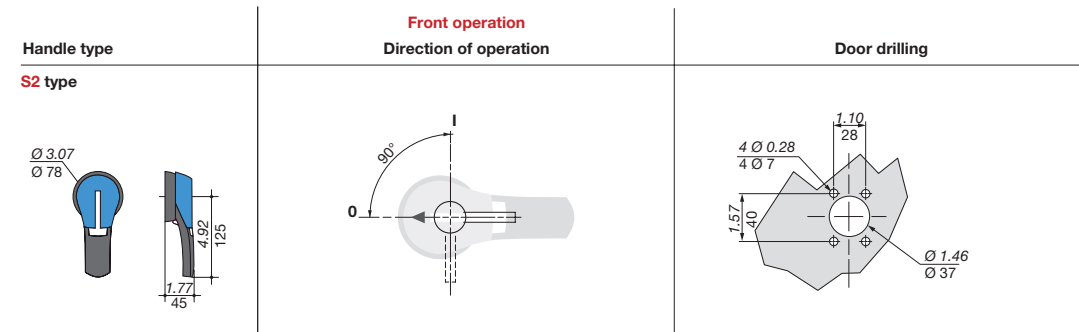

poign_013_a_1_us_cat

600 to 1200 A

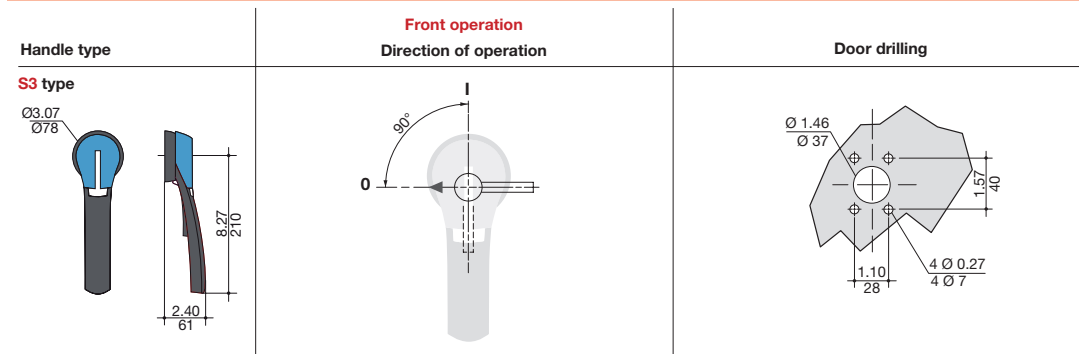

poign_046_a_1_us_cat

600 to 1200 A

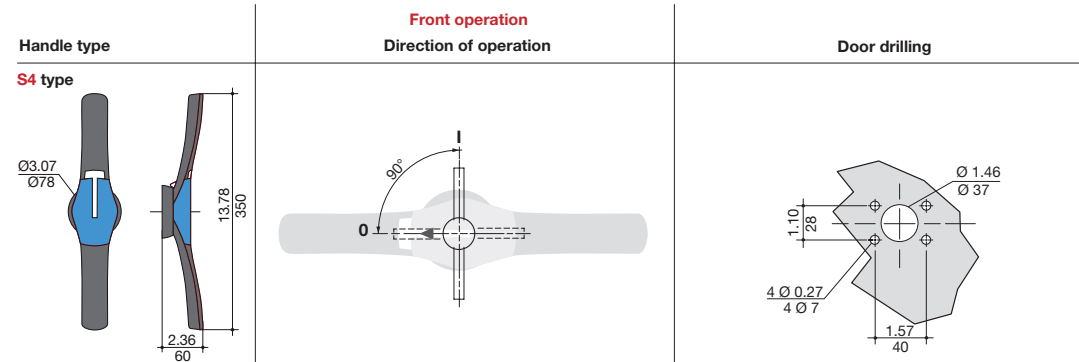

poign_096_a_1_us_cat

Terminal lugs (in/mm)

100 to 200 A

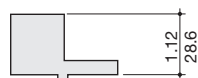
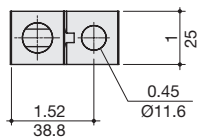

400 A

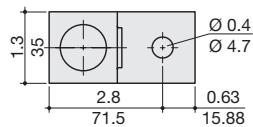

sirco_115_b_1_us_cat

sirco-l_010_b_1_us_cat

400 A

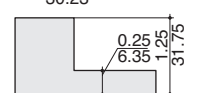
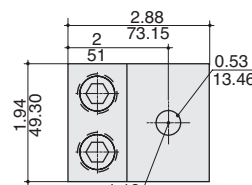

sirco-l_026_b_1_us_cat

600 to 1200 A

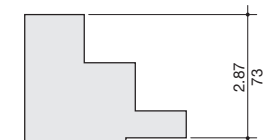
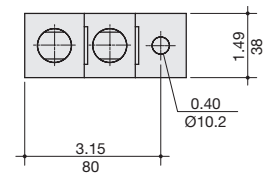

sirco_116_b_1_us_cat

SIRCO UL 98C

Non-fusible switches standards UL and CSA
400 to 1000 A

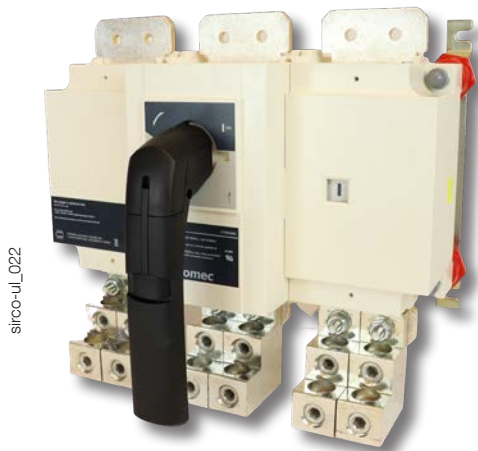

sirco-ul_022

SIRCO
3 x 400 A

Function

SIRCO non-fusible disconnect switches are heavy duty switches that break and make power circuits on and off load and provide safety isolation up to 800 VAC. These switches are extremely durable and are tested and approved for use in the most demanding applications.

General characteristics

- Positive break indication.
- Fully visualized disconnection.
- High thermal and dynamic withstand.
- Severe utilization categories.
- High electrical and mechanical endurance.

The solution for

- > AC Combiner Builders
- > String Inverter Manufacturers
- > Industrial Control Panels Manufacturers (UL 508A)
- > Switchboard Manufacturers (UL 891)
- > Distributors



Strong points

- > Up to 65 kA short circuit rating
- > Reliability
- > Safety of property and personnel
- > Simplicity
- > Easy assembling

Conformity to standards

- > UL 98C
Guide WHY2
File E201138



References

Rating (A)	No. of Poles	Switch Body	Direct handle	External handle	Shaft for external handle	Auxiliary contacts	Terminal protection screens	Terminal lugs kits
400 A	3 P	2700 3042	2699 5052	S2 type Black 1, 3R, 12 142F 2111 ⁽¹⁾	7.9 in 200 mm 1400 1020	1 st contact NO/NC 2799 0021	3 P 2798 3041 ⁽²⁾ 2798 8041 ⁽³⁾	3 P 3954 3040 ⁽⁴⁾
				Red/Yellow 1, 3R, 12 142G 2111 ⁽¹⁾	12.6 in 320 mm 1400 1032			
				Black 4, 4X 142D 2111 ⁽¹⁾	15.7 in 400 mm 1400 1040			
800 A	3 P	2700 3082	3799 6012	S3 type Black 4, 4X 143D 3111 ⁽¹⁾	7.9 in 200 mm 1401 1520	2 nd contact NO/NC 2799 0022	3 P 2798 3120	3 P 3954 3120
1000 A	3 P	2700 3102		Red/Yellow 4, 4X 143E 3111 ⁽¹⁾	12.6 in 320 mm 1401 1532			

Common accessories - more available on next pages

(1) Defeatable handle.

(2) Top.

(3) Bottom.

(4) Top or bottom.

(5) Load side screen, the line side is included with the switch.

Accessories

Direct operation handle

Rating (A)	Color	Handle type	Reference
400	Black	B	2699 5052
800	Black	H	3799 6012
1000	Black	H	3799 6012



B type handle

H type handle

SIRCO UL 98C

Non-fusible disconnect switches

400 to 1000 A

Accessories (continued)

External operation handle

Use

The interlocking function of the front external handle prevents the user from opening the door of the enclosure when the switch is in the "ON" position or when the switch is padlocked in the "OFF" position.

Opening the door when the switch is in the "ON" position is possible by defeating the interlocking function with the use of a tool (authorized persons only). The interlocking function is restored when the door is closed.



S2 type handle

accres_150

Front handle I - 0

Rating (A)	Handle type	Color	Nema type	Reference
400	S2	Black	1, 3R, 12	142F 2111
400	S2	Red/Yellow	1, 3R, 12	142G 2111
400	S2	Black	4, 4X	142D 2111
400	S2	Red/Yellow	4, 4X	142E 2111
800 / 1000	S3	Black	4, 4X	143D 3111
800 / 1000	S3	Red/Yellow	4, 4X	143E 3111



S3 type handle

accres_166

Front handle heavy duty I - 0 with metallic lever

Rating (A)	Handle type	Color	Nema type	Reference
400	S2	Black	4, 4X	142D 2911
400	S2	Red/Yellow	4, 4X	142E 2911
800 / 1000	S3	Black	4, 4X	143D 3911
800 / 1000	S3	Red/Yellow	4, 4X	143E 3911



Heavy duty S2 type handle

accres_236

Shaft for external handle

Use

Standard lengths:

- 7.9 in / 200 mm,
- 12.6 in / 320 mm,
- 15.7 in / 400 mm.

Other lengths: please consult us.

Rating (A)	Dimension X (in)	Dimension X (mm)	Handle type	Length (inches)	Length (mm)	Reference
400	5.31 ... 10.43	135 ... 265	S2	7.9	200	1400 1020
400	5.31 ... 15.16	135 ... 385	S2	12.6	320	1400 1032
400	5.31 ... 18.31	135 ... 465	S2	15.7	400	1400 1040
400	5.31 ... 22.25	135 ... 565	S2	19.7	500	1400 1050
800 / 1000	8.70 ... 13.50	221 ... 343	S3	7.9	200	1401 1520
800 / 1000	8.70 ... 18.23	221 ... 463	S3	12.6	320	1401 1532
800 / 1000	8.70 ... 21.38	221 ... 543	S3	15.7	400	1401 1540
800 / 1000	8.70 ... 26.73	221 ... 679	S3	19.7	536	1401 1554 ⁽¹⁾

(1) UL pending, please consult us.



accres_369

accres_144

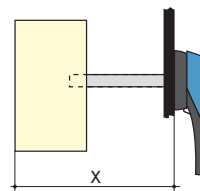

accres_202_a

Alternative color S-type handle cover

Use

For single lever handles type S2 and S3.

Other colors: please consult us.

Handle color	Pack qty	Handle type	Reference
Light grey	50	S2, S3	1401 0001
Dark grey	50	S2, S3	1401 0011



accres_198

S-type handle raiser

Use

Enables S-type handles to be fitted in place of existing older style Socomec handles. Adapter can also be utilized as a spacer to increase the distance between the panel door and the handle lever.

Dimensions

Adds 0.47 in / 12 mm to the depth.

Handle color	Pack qty	Nema type	Reference
Black	10	1, 3R, 12	1493 0000



accres_187

Shaft guide for external handle

Use

This accessory makes shaft introduction easier with up to 0.59 in / 15 mm misalignment. Required for a shaft length over 12.6 in / 320 mm.



access_200

Description	Reference
Shaft guide	1429 0000

Auxiliary contacts

Use

Pre-break and signaling of positions 0 and I. To have 2 NO/NC contacts per switch, please order 1st and 2nd auxiliary contacts per switch. 1st contact is mandatory to operate the 2nd one.

Electrical characteristics

A300 for 100 to 400 A.
A600 for 600 to 1200 A.

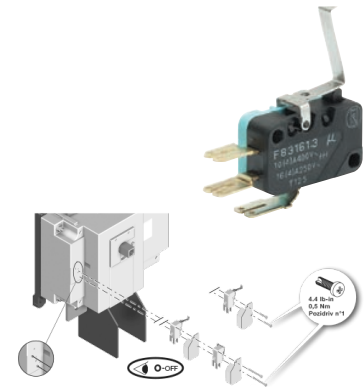

access_076

NO/NC contact for 400 to 1000 A

These auxiliary contacts are for an application of 125-250VAC, 60Hz, general use 10A, 1A 1/2 HP.

Rating (A)	No. of AC	Reference
400 ... 1000	1 st	2799 0021
400 ... 1000	2 nd	2799 0022

Low level NO/NC contact for 400 to 1000 A

Low level auxiliary contacts are for an application of 125VAC, 60Hz, general use 1A.

Rating (A)	No. of AC	Reference
400 ... 1000	1 st	2799 0121
400 ... 1000	2 nd	2799 0122

Terminal screens

Use

Top or bottom protection against direct contact with terminals or connection parts.

Rating (A)	No. of poles	Position	Reference
400	3 P	top	2798 3041
400	3 P	bottom	2798 8041
800 / 1000	3 P	bottom	2798 3120 ⁽¹⁾

(1) Load side screen, the line side is included with the switch.



s_079

Terminal cover

Rating (A)	No. of poles	Position	Reference
400	3 P	top	2794 3041
		bottom	2794 8041

Terminal lugs

Use

Connection of bare copper cables onto the lugs (without lugs).

Rating max (A)	Wires range	No wires per lug	Lugs per kit	Wires	Reference
400	#4 - 600MCM	1	3	Cu / Al	3954 3040
400	2x (#6 - 350MCM)	2	3	Cu / Al	3954 3041
800 - 1000 ⁽¹⁾	4x (#2 - 600MCM)	2	6	Cu / Al	3954 3120

(1) Two lugs per a pole are provided to put side by side per a pole.



UL 032_a

Rating max (A)	Wires range	No wires per lug	Lugs per kit	Wires	Reference
800 - 1000	#2 - 600MCM	2	2	Cu / Al	3954 2060
			3		3954 3060

SIRCO UL 98C

Non-fusible disconnect switches

400 to 1000 A

Characteristics

Characteristics according to UL 98C

General use rating (A)	400 A	800 A	1000 A
Short circuit rating at 800 VAC (kA)	65	65	50
Type of fuse	170M7402	170M6546	170M6548
Max. fuse rating (A)	400	800	1000
Connection terminals			
Min. connection section / AWG	2x #6 / #4	4x #2	4x #2
Max. connection section / AWG	2x 350 / 600MCM	4x 600MCM	4x 600MCM
Mechanical characteristics			
Endurance (number of operating cycles)	6000	3500	3500
Operating torque (lbs.in/Nm)	128.3/14.5	442.5/50	442.5/50
Auxiliary contacts			
Electrical characteristics	A300	A600	A600

Dimensions (in/mm)

400 A

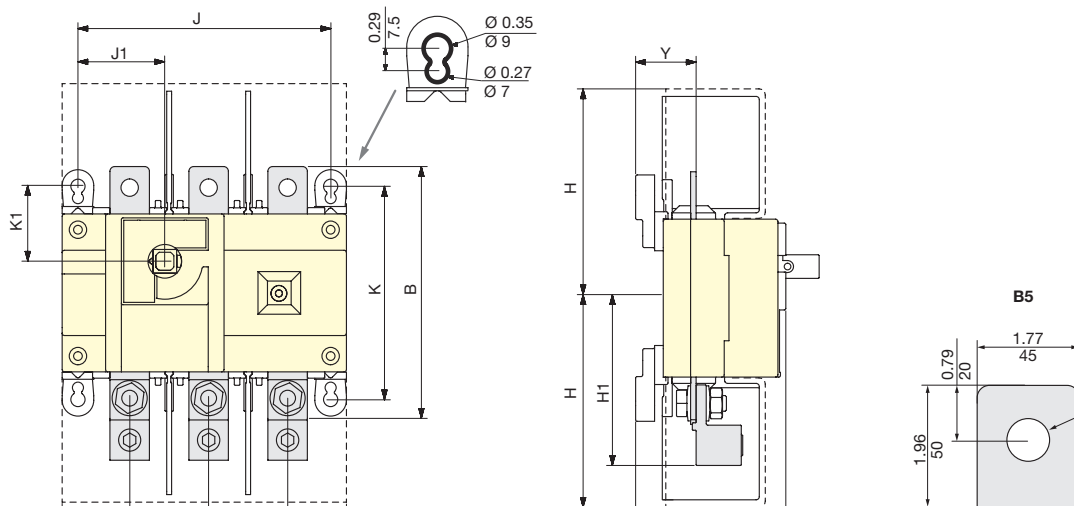

Frame size	No. of poles	Unit	A	B	C	H	H1 max.	J	J1	J2	K	K1	Y
B5	3P	in	9.05	10.23	4.98	8	6.53	8.26	2.95	2.56	7.67	2.65	2.02
		mm	230	230	126.5	203	166	210	75	65	195	67.5	51.5

Dimensions (in/mm) (continued)

800 - 1000 A

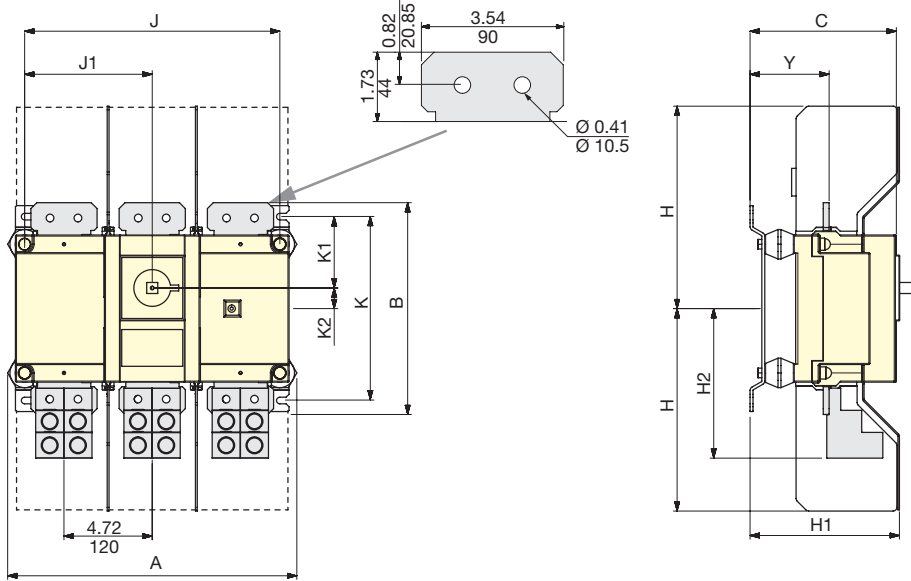

Frame size	No. of poles	Unit	A	B	C	H	H1	H2	H3	J	J1	K	K1	K2	Y
B7	3P	in	15.47	11.33	7.98	10.83	8.30	8.01	9.43	13.68	6.83	9.84	3.82	1.10	4.23
		mm	393	288	200	275	211	203.5	293.5	347	173.5	250	97	28	107.5

400 A

Front direct handle

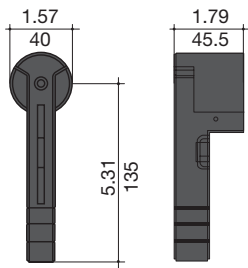

sirco-ul_027_a_1_x_cat

800 - 1000 A

Front direct handle

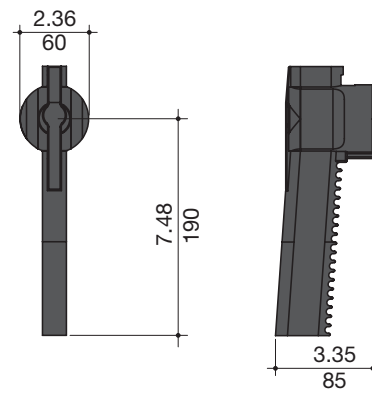

sirco_267_b_1_x_cat

Mounting orientation

400 and 1000 A

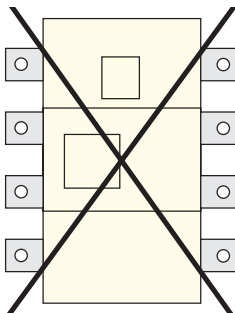

sirco-ul_028_a_1_x_cat

SIRCO UL 98C

Non-fusible disconnect switches

400 to 1000 A

External handle dimensions (in/mm)

400 A

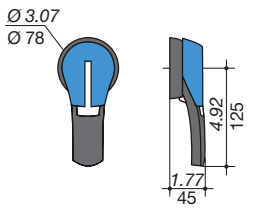
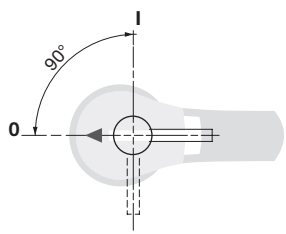
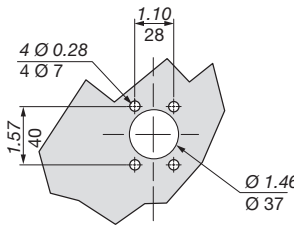
Handle type	Front operation Direction of operation	Door drilling
<p>S2 type</p> 		

poign_013_a_1_us_cat

800 A - 1000 A

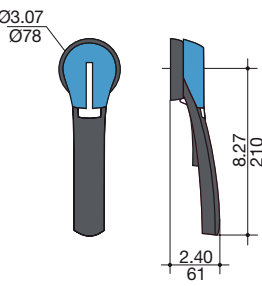
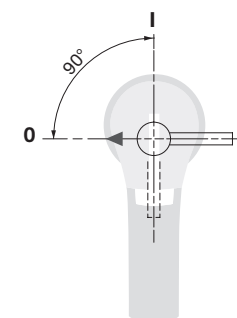
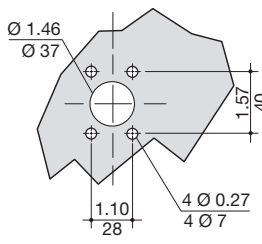
Handle type	Front operation Direction of operation	Door drilling
<p>S3 type</p> 		

poign_046_a_1_gb_cat

Terminal lugs (in/mm)

400 A

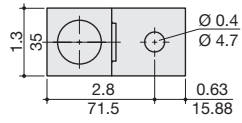

600 kcmil

sirco-ul_010_b_1_us_cat

400 A

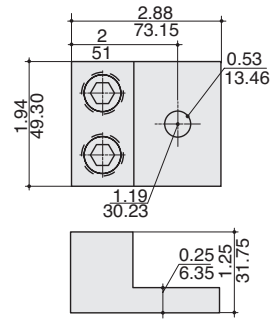

2 x 350 kcmil

sirco-ul_026_b_1_us_cat

800 A - 1000 A

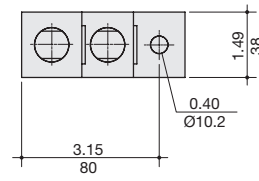

2 x 600 kcmil

sirco_116_b_1_us_cat



Photovoltaic range

A fully tested range for all your PV applications p. 48

Photovoltaic disconnect switches



SIRCO MC PV
UL 508i
25 to 45 A
p. 50



INOSYS LBS
UL 98B
100 to 1200 A
p. 58



INOSYS ESS
800 to 1200 A
p. 70



SIRCO MAN/MOT DC & DC ESS
UL 98B
2000 A
p. 78



FP ESS
160 to 3000 A
p. 82

Expert Services

Our experts are here for you to make your project a success.



A fully tested range for all your PV applications

Using tested and certified components is key for the success of the design for any photovoltaic system. The INOSYS LBS and SIRCO MOT / MAN range is tested and certified according to main standards used in the photovoltaic industry.

Global approvals

Our INOSYS LBS and SIRCO MOT / MAN solar disconnect range meets UL 98B, IEC 60947-3 Standards and bear the CE mark. Using the SOCOMEC range in your design is therefore a unique opportunity to standardize your components and use the same switches on 5 continents.



PV critical current

Under particular conditions PV systems can deliver a low current at high voltage. This type of current is extremely difficult to interrupt. Standard AC or DC products are usually not tested in these particular conditions and could therefore be unable to interrupt low currents at high DC voltage. If the electrical arc produced is not interrupted it may result in operator injury or fire. The INOSYS LBS and SIRCO MOT / MAN range has been specifically designed and tested to interrupt the current under all current/voltage conditions.

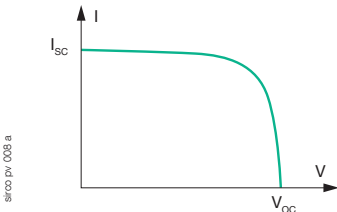

Current (I)/Voltage (V) curve of a PV system. When the current decreases (in the evening or when cloudy) the voltage may increase. SC = Short-circuit, OC = Open-circuit

Short Circuit

The complete UL 98B range is tested to withstand a short circuit of 10 kA for a duration of 50 ms without any specific protection. This allows the use of any overcurrent protection device for line protection.

Thermal current test

Thermal tests have been performed according to both IEC and UL standards.

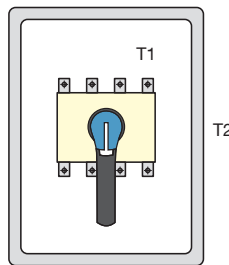

sircopv 005 a



According to UL 98B standard, the maximum difference authorized between T1 (temperature of terminals) and T2 is 40 °K when the switch is fully loaded.



According to IEC 60947-3, switches are tested in free air. Maximum temperature elevation on terminals is 70 °K.

Our UL 98B switches are certified up to 60 °C AMBIENT without derating

The standards for PV disconnect switches

USA

- UL 98B; Disconnect switches for photovoltaic systems, usually for rating above 40 A.
- Manual disconnect switches for photovoltaic systems, usually for ratings up to 40 A.
- UL 1741; Inverters and interconnection system equipment.

Worldwide

- IEC 60947; Low-voltage switchgear and controlgear. Part 3; Switches, disconnectors, switch-disconnectors and fuse-combination units.



The 5th largest European power laboratory

Since 1965, the Pierre Siat test laboratory has used its expertise to guarantee the reliability and compliance of SOCOMEC products and solutions.

This totally independent laboratory is recognized by the major certification bodies worldwide: member of UL, CSA and KEMA. It also works in partnership with numerous international certification organizations (CEBEC, ASTA, Lloyd's, Bureau Véritas, GOST-R, etc.). The quality and safety requirements specific to each country are therefore fully taken into account.

With its 100 MVA (I_{dc} 100 kA rms 1 s) short-circuit platform, three 10 kA overload platforms and numerous other test instruments, in facilities covering 1500 m², the Pierre Siat laboratory is currently the 2nd largest French power



compo 046 a





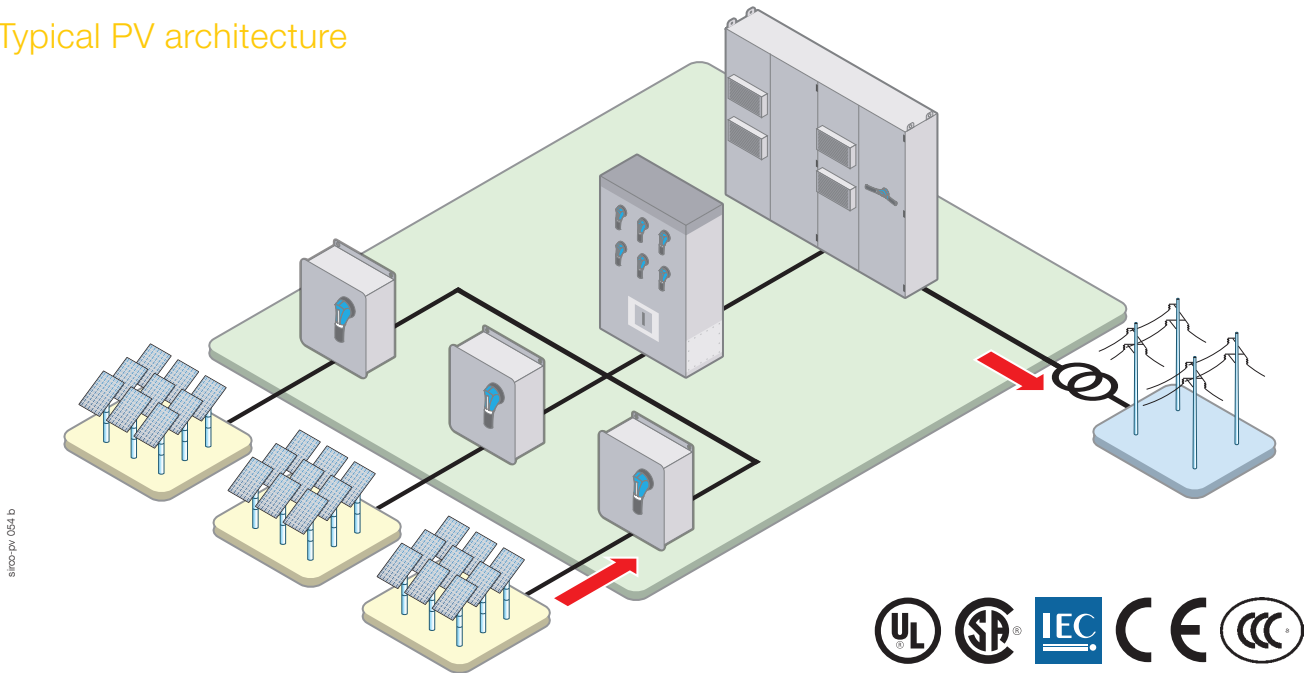

compo 046 a

Socomec DC Non-Fused Disconnects provide safe disconnection and isolation at all levels within your PV installation.

Typical PV architecture

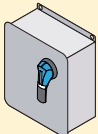

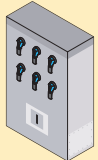
The SOCOMEC solutions

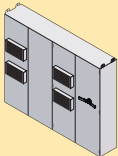
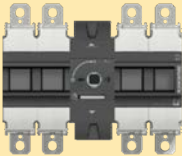
LEVEL OF INSTALLATION	SOCOMEK SOLUTIONS
Combiner box 	 INOSYS LBS One circuit 1200 A at 1500 VDC or two circuits up to 600 A at 1500 VDC  SIRCO MC PV UL 508i One circuit or two circuits up to 1000 VDC
Recombiner box 	 INOSYS LBS Two circuit up to 600 A at 1500 VDC
Inverter 	 INOSYS LBS One circuit up to 1200 A at 1500 VDC

SIRCO MC PV UL 508i

Non-fusible disconnect switches for photovoltaic applications
from 25 to 45 A, up to 1000 VDC



SIRCO MC PV 25 A - 1000 VDC
DIN-rail mounting

The solution for

- > Residential
- > Buildings
- > Solar parks



Strong points

- > Compact
- > High breaking capacity up to 1000 VDC
- > Safety

Conformity to standards

- > UL 508i
Guide NMSJ
File E365404
- > IEC 60947-3



Approvals and certifications⁽¹⁾



⁽¹⁾ Product reference on request.

Function

SIRCO MC PV are DC non-fusible disconnect switches. They make and break under load conditions and provide optimum safe isolation for any PV circuit.

Advantages

Compact

Due to its compact design, the space needed within the combiner box or the solar inverter is greatly reduced.

High breaking capacity up to 1000 VDC

- Making and breaking capacity under load conditions up to 1000 VDC.
- Specific photovoltaic test beyond requirements of UL 508i and IEC 60947-3 standard.

Safety

- Bridging bars are factory fitted for easier, quicker and safer connection.
- Direct access to connection terminals for adequate tightening.

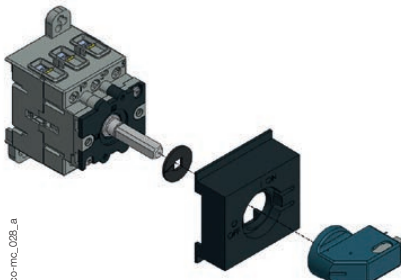

SIRCO MC PV
DIN-rail mounting

Multi-circuit switching

- The SIRCO MC PV for dual circuits (2 MPPT: Maximum Power Point Tracking) enables connection of two independent photovoltaic circuits to a single switch in order to reduce the costs of the global solution.

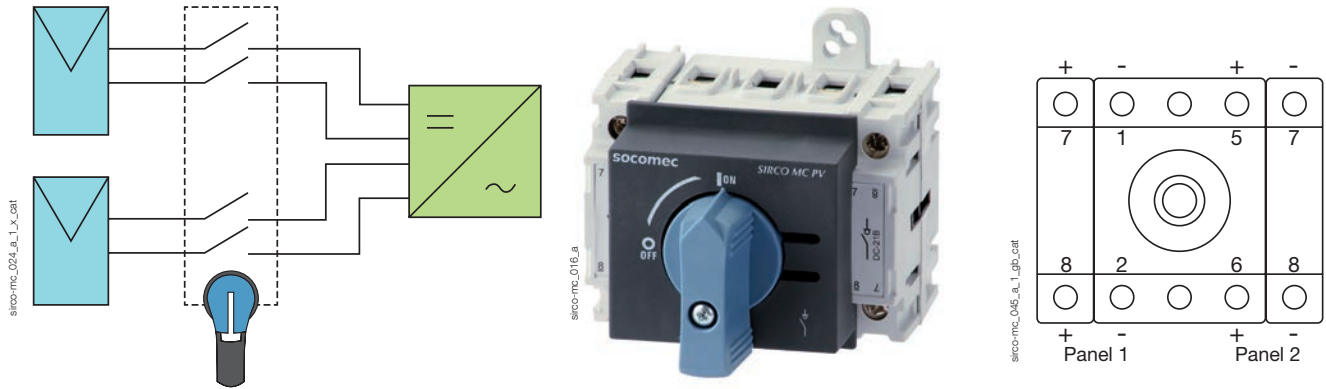

What you need to know

For grounded or ungrounded networks:

It is possible to use the SIRCO MC PV in both network systems, either switching one or both polarities.

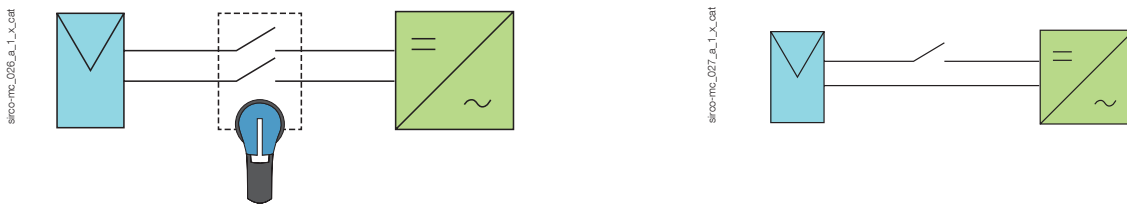

SIRCO MC PV UL 508i

Non-fusible disconnect switches for photovoltaic applications
from 25 to 45 A, up to 1000 VDC

References

600 VDC

Rating (A)	Circuit type	No. of poles	Switch body	Direct handle	External handle	Shaft for external handle	Auxiliary contact
25 A	Single PV circuit	2 P	21PV 2102-UL	MC01 type Blue 2119 1012	S00 type Black 4.4X 147D 0111 ⁽¹⁾	S00 type 10.43 in 265 mm 2107 0517	1 contact NC+NO 2119 0001
	Dual PV circuit	4 P	21PV 5102-UL				
45 A	Single PV circuit	4 P	21PV 4144	MC01 type Blue 2119 1412	Red 4.4X 147R 0111 ⁽¹⁾		
	Dual PV circuit	8 P	21PV 8144				

Common accessories - more available on next pages.

(1) Door interlocking.

1000 VDC

Rating (A)	Circuit type	No. of poles	Switch body	Direct handle	External handle	Shaft for external handle	Auxiliary contact
32 A	Single PV circuit	4 P	21PV 4144	MC01 type Black 2119 1012	S00 type Black 4.4X 147D 0111 ⁽¹⁾	S00 type 10.43 in 265 mm 2107 0517	1 contact NC+NO 2119 0001
	Dual PV circuit	8 P	21PV 8144	MC01 type Black 2119 1412			

Common accessories - more available on next pages.

(1) Door interlocking.

Accessories

Direct operation handle

Rating (A)	Handle color	Type of locking	Handle type	45 mm modular DIN front plate	Reference
25 ... 45	Blue	-	MC0	yes	2119 0012
25 ... 45	Blue	1 padlock Ø 0.20 in / 5 mm	MC01	yes	2119 1012
45	Blue	1 padlock Ø 0.20 in / 5 mm	MC01	yes	2119 1412



MC0 handle

acces_305_a_1_cnf



MC01 handle

acces_293_a_1_cnf

External operation handle

Use

The external control will allow the operator to safely disconnect and isolate the solar strings prior to any intervention.

External controls are user-friendly and adapted to meet requirements of residential installations, large roofs and ground-based generators.



S00 handle



MC1 handle

access_341_a_1_cat

access_302_a_1_cat

DIN-rail or back plate mounting

Rating (A)	Handle type	Handle color	Type of locking	Nema type	Reference
25 ... 45	MC1	Black	3 padlocks Ø 0.35 in / 8 mm	4, 4X	2119 3312
25 ... 45	MC1	Red/Yellow	3 padlocks Ø 0.35 in / 8 mm	4, 4X	2119 3313
25 ... 45	S00	Black	3 padlocks Ø 0.35 in / 8 mm	4, 4X	147D 0111
25 ... 45	S00	Red/Yellow	3 padlocks Ø 0.35 in / 8 mm	4, 4X	147R 0111

Shaft for external handle

Use

The shaft can be adjusted and cut depending on the need.

Shaft length

Device + shaft:
- 10.43 in / 265 mm



access_297_a_1_cat

DIN-rail or back plate mounting

Rating (A)	Device + shaft Length	Reference
25 ... 45	10.43 in / 265 mm	2107 0517⁽¹⁾

(1) Shaft for door interlocking.

Terminal shrouds

Use

Top or bottom protection against direct contact with the terminals or connection parts. 1 and 3 poles are available.

The SIRCO MC PV non-fusible disconnect switch is pre-bridged. Terminal covers are mounted on the top or bottom free space of the device.

Possibility to assemble a terminal shroud on the bridge side by removing the insulating material of the series connection bar (irreversible step).

Rating (A)	Type of mounting	No. of poles	Position	Reference
25 ... 45	DIN-rail	1 P	top or bottom	2194 1004
25 ... 45	DIN-rail	3 P	top or bottom	2194 3004

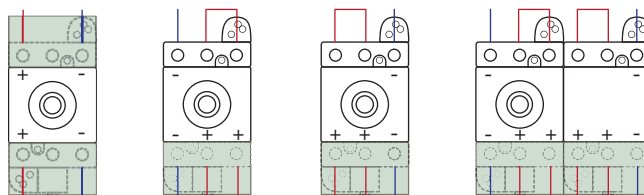

sirco-mc_011_a_1_cat



Terminal shrouds 1 pole



Terminal shrouds 3 pole

access_299_a_1_cat

access_300_a_1_cat

SIRCO MC PV UL 508i

Non-fusible disconnect switches for photovoltaic applications
from 25 to 45 A, up to 1000 VDC

Characteristics

According to UL 508i

			25 A	45 A
General use rating with 200% overload extra test				
Rated voltage	Number of poles of the device	Number of PV circuits	(A)	(A)
600 VDC	2 P	1	25	-
600 VDC	4 P	1	-	45
600 VDC	2 x 2 P	2	25	-
600 VDC	2 x 4 P	2	-	45
1000 VDC	4 P	1	-	32
1000 VDC	2 x 4 P	2	-	32
Short-circuit capacity at 600 VDC				
Prospective short-circuit current (kA rms)			5	5
Type of fuse			gPV	gPV
Associated fuse rating (A)			25	80
Short-circuit capacity at 1000 VDC				
Prospective short-circuit current (kA rms)			5	5
Connection terminals				
Min. connection wire range / AWG (solid or stranded)			14 / 7	14 / 3
Mechanical characteristics				
Durability (number of operating cycles)			30,000	30,000
Tightening torque (Nm)			2	2

According to IEC 60947-S

		25 A	45 A	
Rated current				
Thermal current I_{th} at 40°C (A)		25	45	
Thermal current at 50°C (A)		25	45	
Thermal current at 60°C (A)		25	45	
Rated insulation voltage U_i (V)		1,000	1,000	
Rated impulse withstand voltage U_{imp} (kV)		8	8	
Rated operational currents I_e (A)				
Rated voltage	Number of poles of the device	Number of PV circuits	(A)	(A)
600 VDC	2 P	1	30	-
600 VDC	4 P	1	-	40
600 VDC	2 x 2 P	2	30	-
600 VDC	2 x 4 P	2	-	40
1000 VDC	2 P	1	10	-
1000 VDC	4 P	1	-	40
1000 VDC	2 x 2 P	2	10	-
1000 VDC	2 x 4 P	2	-	40

Dimensions (in/mm)

DIN-rail mounting - Direct operation

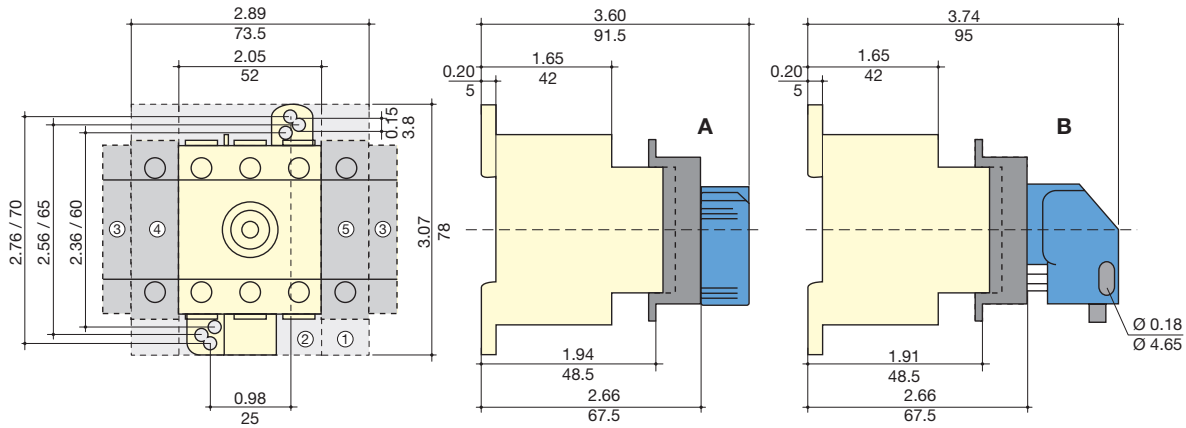

- 1. Terminal shrouds 1P.
- 2. Terminal shrouds 3P.
- 3. Auxiliary contact.
- 4. AC power pole.
- 5. AC or PV power pole.
- A. MC0 handle
- B. MC0 handle

DIN-rail mounting - External operation

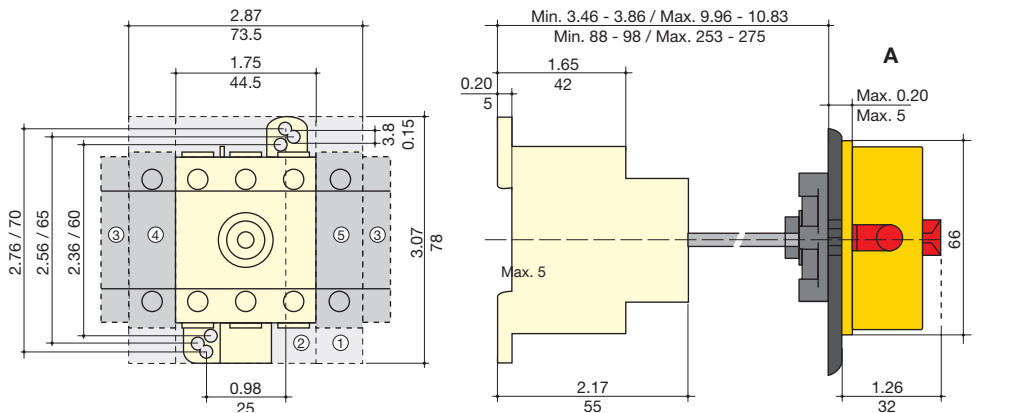

- 1. Terminal shrouds 1P.
- 2. Terminal shrouds 3P.
- 3. Auxiliary contact.
- 4. AC power pole.
- 5. AC or PV power pole.
- A. MC1 handle

2 MPPT - 45 A - 600 VDC and 32 S - 1000 VDC - DIN-rail mounting - Direct operation

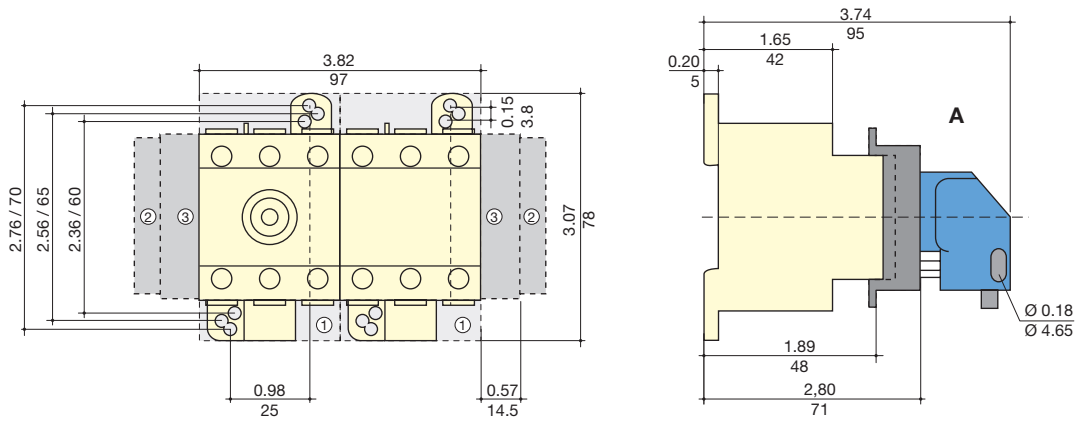

- 1. Terminal shrouds 3P.
- 2. Auxiliary contact.
- 3. PV power pole.
- A. MC01 handle.

SIRCO MC PV UL 508i

Non-fusible disconnect switches for photovoltaic applications
from 25 to 45 A, up to 1000 VDC

Dimensions (continued)

DIN-rail mounting - External operation

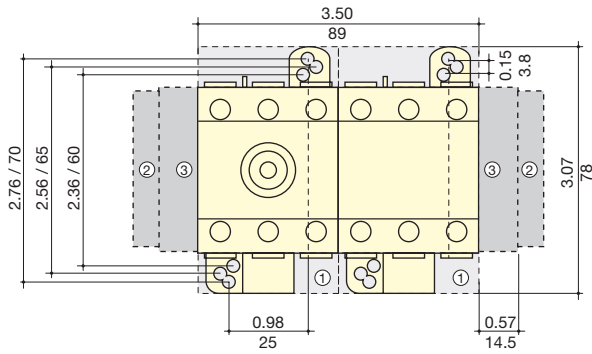

1. Terminal shrouds 3P.

2. Auxiliary contact.

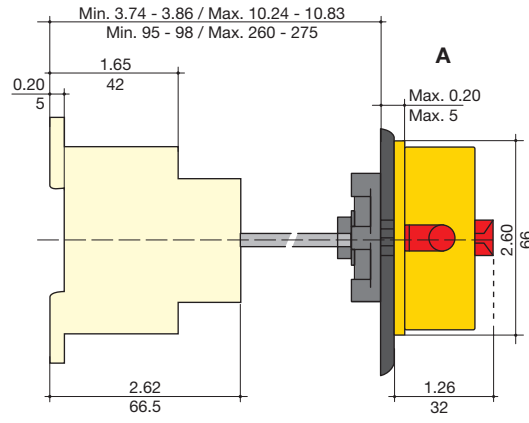

A. MC1 handle.

sirco-mc_040_b_1_us_cat

Dimensions for external handles (in/mm)

DIN-rail or back plate mounting

Handle type	Front operation Direction of operation	Door drilling
<p>MC1 type</p> <p>poign_001_a_1_us_cat</p>		
<p>S00 type</p> <p>poign_056_a_1_us_cat</p>		<p>With 4 fixing screws</p> <p>With fixing nut</p>

Poles connections

Switching of polarities + and - ⁽¹⁾

	Single PV circuit	Dual PV circuit
	<p><small>sirco-mc_023_a_1_x_cat</small></p>	<p><small>sirco-mc_024_a_1_x_cat</small></p>
Rating	Single PV circuit	Dual PV circuit
25 A - 600 VDC	<p>21PV 2102-UL</p> <p><small>sirco-mc_044_a_1_lgb_cat</small></p>	<p>21PV 5102-UL</p> <p><small>sirco-mc_045_a_1_lgb_cat</small></p>
45 A - 600 VDC 32 A - 1000 VDC	<p>21PV 4144</p> <p><small>sirco-mc_083_a_1_lgb_cat</small></p>	<p>21PV 8144</p> <p><small>sirco-mc_085_a_1_lgb_cat</small></p>

(1) For grounded systems, single polarity switching, a bridge shall be added.
 For spare bridging bars, please consult us.

INOSYS *LBS* UL 98B

Load Break Switches for DC & PV applications
from 100 to 1200 A, up to 1500 VDC

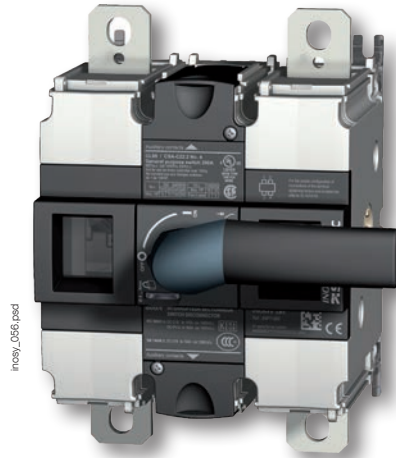

Also
available up
to 2000kV

The solution for

- > Combiner box
- > Recombiner box
- > Solar Inverter

Strong points

- > High performance power switching in a compact frame
- > Safe & reliable operation
- > Designed for harsh environments
- > Easy to install
- > Modular solution for flexible configuration

Conformity to standards

- > UL 98B
Guide WHVA
File E346418



- > IEC 60947-3,
DC-21B & DC-PV2



- > CCC



Function

INOSYS LBS is a range of load break switches that can be manually controlled. These switches can be operated manually using the handle to disconnect all or part of the electrical installation. They ensure on-load opening / closing and safe disconnection of any direct current low voltage electrical circuit up to 1500 VDC. They can also be used for emergency power switching applications. They are available for DC-PV2 utilization category.

Advantages

High-performance switching in a compact frame

INOSYS LBS load break switches incorporate patented technology that provides a breaking capacity of 750 VDC per pole, providing 1500 VDC in just 2 poles, and significantly limiting power dissipation. All in an exceptionally compact device.

Safe & reliable operation

- Direct position indication on the bar and visible contact with containment of the electrical arc.
- The opening and closing of the switch is fully independent from the speed of operation, ensuring safe operation under all conditions.
- High temperature withstand: no derating up to 131° F (55 °C), functional from -40 to +122 °F (-40 to +50 °C).

Designed for harsh environments

- Vibration testing (from 13.2 to 100 Hz at 0.7 g).
- Shock testing (15 g during three cycles).
- Humid temperature testing (2 cycles, 131°F/55°C with 95% humidity level).
- Salt mist testing (3 cycles with humidity storage, 104°F/40°C, 93% humidity after each cycle).

Easy to install

- Wiring: as the switch is non-polarized all types of wiring and connections are possible.
- Easy access without tools to integrate auxiliary contacts (located within the switch footprint).
- Mechanism can be centred or left aligned (in the factory) to accommodate installation requirements.

Modular solution for flexible configuration

- Single or dual polarity switching
- The same switch can be used for installation with either grounded or floating networks by choosing the wiring configuration.

General characteristics

- Range from 100A to 1200A.
- Up to 1500 VDC.
- High-performance switching in a compact design.
- Easy integration.
- Reinforced safety with visible contact indication.
- Efficient with low power-loss.

Typical applications: local safe disconnection for DC and PV applications

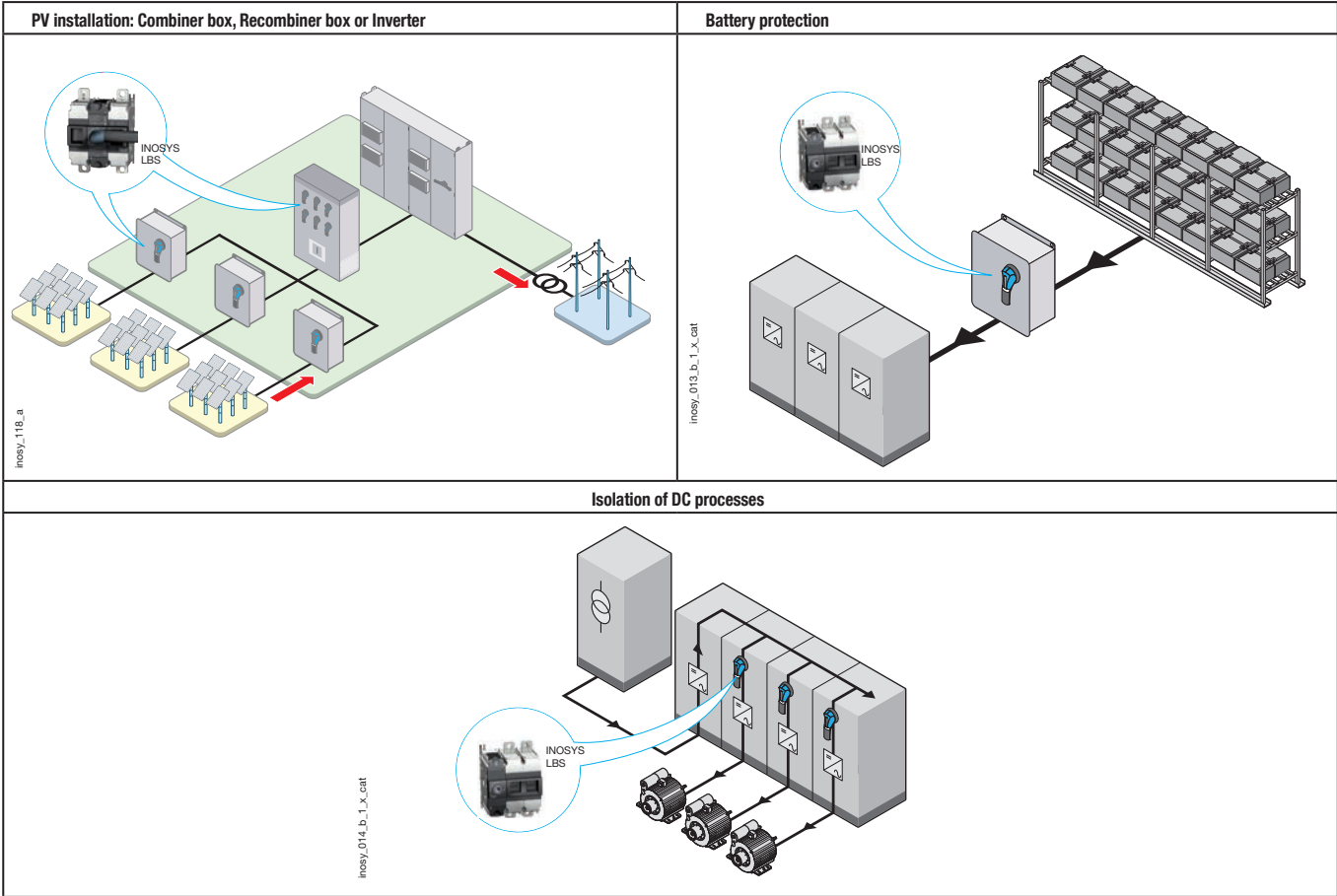

Overview



1. INOSYS LBS
2. External operation handle
3. Direct operation handle
4. Shaft for external operation
5. Auxiliary contact
6. Inter-phase barriers
7. Terminal shrouds
8. Terminal screen
9. Bridging bar to arrange the poles in series
10. Captive nut
11. Mounting insert
12. Cage terminals
13. Isolation plate

INOSYS LBS UL 98B

Load Break Switches for DC & PV applications
from 100 to 1200 A, up to 1500 VDC

References

INOSYS LBS

1000 VDC - 1 circuit

Rating (A)	Frame size	No. of poles per circuit	Switch body ⁽¹⁾	External operation	Aux. Contact	Bridging Bar ⁽²⁾
100 A	F2	2 P	87P0 2010	Shaft 12.6 inches 320 mm 1400 1032	NO/NC 8499 0001	8409 0016
250 A	F2	2 P	87P0 2025	S2 type handle Black 3R, 12 - 4, 4X 742D 2111		
400 A	F3	2 P	87P0 2040	Shaft 12.6 inches 320 mm 1400 1032		8409 0040
500 A	F3	2 P	87P0 2050	S2L type handle Black 3R, 12 - 4, 4X 14AD 2111		8409 0041

(1) The switches are supplied without accessories.

(2) For grounded network, single polarity switching.

1500 VDC - 1 circuit

Rating (A)	Frame size	No. of poles per circuit	Switch body ⁽¹⁾	External operation	Aux. Contact	Bridging Bar ⁽²⁾
100 A	F2	2 P (1 P+, 1 P-)	87P0 2011	Shaft 12.6 inches 320 mm 1400 1032	NO/NC 8499 0001	8409 0016
			87P1 1011 ⁽³⁾			8409 0024
200 A	F2	2 P (1 P+, 1 P-)	87P0 2021	S2 type handle Black 3R, 12 - 4, 4X 742D 2111	NO/NC 8499 0001	8409 0016
			87P1 1021 ⁽³⁾			8409 0024
250 A	F2	2 P (1 P+, 1 P-)	87P0 2026	S2L type handle Black 3R, 12 - 4, 4X 14AD 2111	NO/NC 8499 0001	8409 0016
			87P1 1026 ⁽³⁾			8409 0024
		3 P (2 P+, 1 P-)	87P0 3025	Shaft 12.6 inches 320 mm 1400 1032	NO/NC 8499 0001	2x 8409 0025
			87P1 1061 ⁽³⁾			8409 0040
400 A	F3	2 P (1 P+, 1 P-)	87P0 2042	S2L type handle Black 3R, 12 - 4, 4X 14AD 2111	NO/NC 8499 0001	8409 0040
			87P1 1041 ⁽³⁾			8409 0039
500 A	F3	2 P (1 P+, 1 P-)	87P0 2051	S2L type handle Black 3R, 12 - 4, 4X 14AD 2111	NO/NC 8499 0001	8409 0039
			87P1 1051 ⁽³⁾			8409 0041
600 A	F3	2 P (1 P+, 1 P-)	87P0 2061	S2L type handle Black 3R, 12 - 4, 4X 14AD 2111	NO/NC 8499 0001	8409 0063
			87P1 1061 ⁽³⁾			Consult us

1500 VDC - 2 circuits

Rating (A)	Frame size	No. of poles per circuit	Switch body ⁽¹⁾	External operation	Aux. Contact	Bridging Bar ⁽²⁾
400 A	F3	2 P (1P+, 1P-)	87P2 2041 ⁽³⁾	Shaft 12.6 inches 320 mm 1400 1032	NO/NC 8499 0001	8409 0041 8409 0063 ⁽⁴⁾
500 A			87P2 2051 ⁽³⁾	S2L type handle Black 3R, 12 - 4, 4X 14AD 2111		8409 0063
600 A			87P2 2061 ⁽³⁾			

(1) The switches are supplied without accessories.

(2) For isolated networks.

(3) Centered mechanism.

(4) In side mounting.

1500 VDC - high rating

Rating (A)	Frame size	No. of poles per circuit	Switch body ⁽¹⁾	External operation	Aux. Contact	Bridging bar
800 A	F3	4P (2P // 2P)	87P2 2081	Shaft 12.6 in / 320 mm 1400 1032	NO/NC 8499 0001	8409 1600
1000 A			87P2 2100	S2L type Handle Black 3R, 12 - 4, 4X 14AD 2111		
1200 A			87P2 2120			

(1) The switches are supplied without accessories.

Accessories

Direct operation handle

Frame size	Handle type	Handle colour	Reference
F2	E2	Black	8499 5022
F2	E2	Red	8499 5023
F3	E3	Black	8499 5032



E3 handle

access_400_a_1_cat

Door interlocked external operation handle

Use

Door interlocked external operation handles include an escutcheon and are padlockable. External handles must be utilized with an extension shaft.

Example

As the handle is interlocked in the "ON" position the operator must safely disconnect and isolate the circuit prior to accessing the panel for maintenance procedures.

Opening the door when the switch is in the "ON" position can only be done by defeating the interlocking function with the use of a dedicated tool (authorized personnel only). The interlocking function is restored when the door is re-closed.



S2 type handle

access_150_aps

Frame size	Handle type	Handle colour	Degree of protection	Front operation	Lateral operation
				Reference	Reference ⁽²⁾
F2	S2	Black	3R,12	742F 2111	
F2	S2	Black	4,4X	742D 2111	142J 6111
F2	S2	Red	4,4X	742E 2111	
F3	S2L ⁽¹⁾	Black	3R,12	14AF 2111	
F3	S2L ⁽¹⁾	Black	4,4X	14AD 2111	14AJ 2111
F3	S2L ⁽¹⁾	Red	4,4X	14AE 2111	

(1) S2L handles have an extended grip; please refer to the dimensions section.

(2) only compatible with left mechanism version.

Shaft for external handle

Frame size	Handle type	Length (in/mm)	Reference
F2 - F3	S2, S2L	7.87/200	1400 1020
F2 - F3	S2, S2L	12.6/320	1400 1032
F2 - F3	S2, S2L	15.75/400	1400 1040

Other lengths: please consult us.



Shaft for S2 and S2L type handle

access_401_a_1_cat

INOSYS **LBS** UL 98B

Load Break Switches for DC & PV applications
from 100 to 1200 A, up to 1500 VDC

Accessories (continued)

Isolation plate

Use

This isolation plate ensure safety for the customer.

Characteristics

Products above 800A are supplied from factory with isolation plates. For replacement purposes, quantity to order should be 2 kits.



access_599.jpg

Description	Quantity to order	Reference
Isolation plate	2	8499 1000 ⁽¹⁾

(1) Kit includes 2 identical isolation plates

Auxiliary contact

Use

The function of the auxiliary contact depends on where it is mounted on the mechanism.

Characteristics

Changeover type: NO/NC,
IP2X with front operation
(cover tap screwed).
10,000 operations.
Maximum 3 per switch.



access_402_a_1_cat

Frame size	Connection type	Type	Reference
F2 - F3	Screw	NO/NC standard	8499 0001
F2 - F3	Screw	NO/NC standard	8499 0002
F2 - F3	Screw	NC > 600 V	8499 0002

Characteristics

Auxiliary contact type	Min. current (A)	I _{th} (A)	Electrical characteristics per UL 60947-5-1
Standard	12.5 mA / 24 V	10	A300 - R300 - Q150
Low level	1 mA / 4 V	10	A300 - R300 - Q150
> 600 V	10 mA / 24 V	10	A600

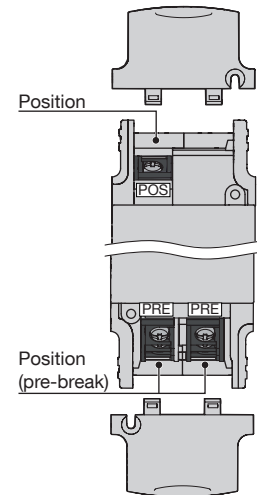

access_485_a_1_gpd_cat

Bridging bar for poles in series

Use

The bridging bars enable the poles to be connected in series, allowing the following configurations for 1500 VDC.

1000 VDC - 1 circuit

Frame size	Rating (A)	No. of poles	Quantity to be ordered	Reference
F2	100	2 P	1	8409 0016
F2	250	2 P	1	8409 0016
F3	400	2 P	1	8409 0040
F3	500	2 P	1	8409 0041
F3	600	2 P	1	8409 0063

1500 VDC - 1 circuit

Frame Size	Rating (A)	No. of poles	Quantity to be ordered	Reference
F2	100	3 P	2	8409 0016
F2	250	3 P	2	8409 0025
F3	400	2 P	1	8409 0040
F3	500 ... 600	2 P	1	8409 0041 8409 0063
F3	800 ... 1200	2P	2	8409 1600

1500 VDC - 2 circuits

Frame Size	Rating (A)	No. of poles	Quantity to be ordered	Reference
F3	400	2 P	2	8409 0041 8409 0063
F3	500 ... 600	2 P	2	8409 0063

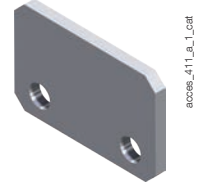

exce_411_b_1_c28

Terminal screen

Use

Provides top and bottom protection against direct contact with terminals or connection parts.

Advantages

Perforations for thermal checks.
Assembly requires mounting inserts (provided with terminal screens).

Frame size	No. of poles	Position	Reference ⁽¹⁾
F2	2 P	Top and bottom	8499 3222
F2	3 P	Top and bottom	8499 3232
F3	2 P	Top and bottom	8499 3722

(1) Each reference comprises 2 terminal screens for top and bottom protection.



exce_408_a_1_c21

INOSYS **LBS** UL 98B

Load Break Switches for DC & PV applications
from 100 to 1200 A, up to 1500 VDC

Accessories (continued)

Holding insert

Use

Used to secure terminal screens on the switch.

Frame size	Pack (unit)	Reference
F2 - F3	10	8499 6220
F2 - F3	100	8499 6221



acce_409_a_1_cat

Captive nut

Use

This accessory enables simple one-handed connection to the power terminals. It can be mounted on either side of the terminal for front or rear connection.

Frame size	Pack (unit)	Reference
F2	12	8499 6120
F2	120	8499 6121
F3	12	8499 6130
F3	120	8499 6131

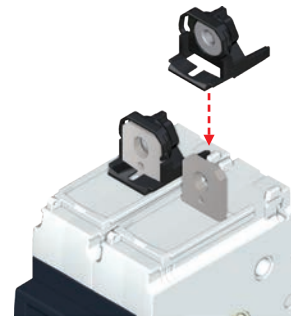

acce_399_a_1_cat

Voltage tap

Use

Allows connection of voltage sensing or power cables, with fast-on connection.

Frame size	Pack (unit)	Reference
F2	12	8499 9012
F3	12	8499 9013



acce_412_a_1_cat

Terminal lugs

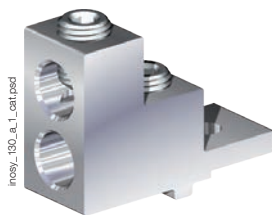

inosy_190_a_1_cat.psd

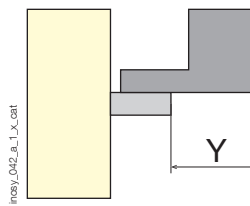

inosy_042_a_1_x_cat

Frame size	Number and size (min. - max.) of cables	Type of cable	Openings per lug	Quantity per reference	Dimension "Y" (mm/in)	Reference ⁽¹⁾
F3	2 conductors (#2 - 600 KCMIL)	Cu / Al	2	2	69,7 / 2.74	3954 2060 ⁽¹⁾
F3		Cu / Al		3		3954 3060 ⁽¹⁾
F3		Cu / Al		4		3954 4060 ⁽¹⁾

(1) Captive nut 8499 6xxx is mandatory.

Characteristics

Characteristics according to UL 98B

Rated current I _n	100 A	200 A	250 A	400 A	500 A	600 A
Frame size	F2	F2	F2	F3	F3	F3
Number of poles(s) in series per polarity - 1000VDC	2 P	2 P	2 P	2 P	2 P	2 P
Number of poles(s) in series per polarity - 1500VDC	2 P / 3 P	2 P / 3 P	2 P / 3 P	2 P	2 P	2 P
Number of pole(s) of the device - 1000VDC	2 P	2 P	2 P	2 P	2 P	2 P
Number of pole(s) of the device - 1500VDC	2 P / 3 P	2 P / 3 P	2 P / 3 P	2 P	2 P	2 P
Short-circuit capacity at 1000 & 1500VDC (with protection)						
Prospective short-circuit current (kA rms DC)	10 ⁽¹⁾	10 ⁽¹⁾	10 ⁽¹⁾	10 ⁽¹⁾	10 ⁽¹⁾	10 ⁽¹⁾
Mechanical characteristics						
Durability (number of operating cycles)	8000	8000	8000	8000	8000	8000
Power loss/pole (W/Pole)	2	5.1	11.2	13	21.6	29.3

(1) Without fuse during 50 ms.

Characteristics according to IEC 60947-3

Rated current I _n			160 A	250 A	315 A	400 A	500 A	630 A
Frame size			F2	F2	F2	F3	F3	F3
Thermal current at 40 °C (A)			160	250	315	400	500	630
Thermal current at 50 °C (A)			160	250	315	400	500	630
Thermal current at 60 °C (A)			160	250	315	400	500	630
Thermal current at 70 °C (A)			160	250	315	400	480	580
Thermal current at 80 °C (A)			140	220	280	360	430	520
Rated insulation voltage U _i (V)			1500	1500	1500	1500	1500	1500
Rated impulse withstand voltage U _{imp} (kV)			12	12	12	12	12	12
Number of circuits	Nominal voltage	Utilisation category	I_e (A)	I_e (A)	I_e (A)	I_e (A)	I_e (A)	I_e (A)
1 circuit	1000 VDC ⁽¹⁾	DC-21 B	160	250	315	400	500	630
1 circuit	1500 VDC ⁽²⁾	DC-21 B	160	250	315	400	500	630
Number of circuits	Nominal voltage	Utilisation category	I_e (A)	I_e (A)	I_e (A)	I_e (A)	I_e (A)	I_e (A)
1 circuit	1000 VDC ⁽¹⁾	PV2	-	-	-	-	-	-
1 circuit	1500 VDC ⁽²⁾	PV2	160	250	315	400	500	630
2 circuits	1500 VDC ⁽²⁾	PV2	-	-	-	400	500	630
Short-circuit operation at 1000 VDC and 1500 VDC (unprotected)								
Current rated as short-time withstand I _{sw} 1s (kA rms)			10	10	10	10	10	10
Rated short-circuit breaking capacity I _{cm} (peak kA) – 60 ms			10	10	10	10	10	10
Connection								
Recommended Cu rigid cable cross-section ⁽³⁾			70	120	185	240	2 x 150	2 x 185
Recommended width of copper bars (mm) ⁽³⁾			20	20	20	25	25	25
Mechanical characteristics								
Durability (number of operating cycles)			8000	8000	8000	8000	8000	8000
Power dissipation per pole (W/pole)			4.5	11.2	13	13	21.6	30.2

(1) 2 poles in series.

(2) 2 or 3 poles in series.

(3) For aluminium connections, please contact us.

INOSYS LBS UL 98B

Load Break Switches for DC & PV applications
from 100 to 1200 A, up to 1500 VDC

Characteristics (continued)

Characteristics according to UL 98B

Rated current I _n		800	1000	1200
		(A)	(A)	(A)
Short circuit capacity (UL)				
Prospective short-circuit current (kA rms DC) (kA rms)	UL 98B	10	10	10
Mechanical characteristics				
Durability (number of operating cycles)		8000	8000	8000
Power dissipation per pole (W/pole)		14	21	31

Characteristics according to IEC 60947-3

Rated current I _n		800	1000	1250
		(A)	(A)	(A)
Rated insulation voltage U _i (V)		1500	1500	1500
Rated impulse voltage U _{imp} (kV)		12	12	12
Frame Size		F3	F3	F3
Rated voltage	Ambient temperature (°C)	63	63	63
1500 VDC	40	800	1000	1250
1500 VDC	50	800	1000	1250
1500 VDC	60	720	900	1120
1500 VDC	70	650	810	1010
1500 VDC	80	580	730	910
Rated voltage	Utilisation category	63	63	63
1500 VDC	DC-21 B	800	1000	1250
1500 VDC	PV1	800	1000	1250
1500 VDC	PV2	800	1000	1250
Short circuit capacity				
"Rated short time withstand current I _{cw} 1s (kA rms)"	IEC 60947-3	20	20	20
"Rated short-circuit making capacity I _{cm} (kA peak)"	IEC 60947-3	20	20	20
Connection				
Rigid Cu cable cross-section (mm ²)		4 x 400	4 x 400	4 x 600
Maximum Cu busbar width (mm)		10 x 100	10 x 100	-
Tightening torque min (Nm)		35	35	35
Tightening torque max (Nm)		42	42	42

INOSYS LBS

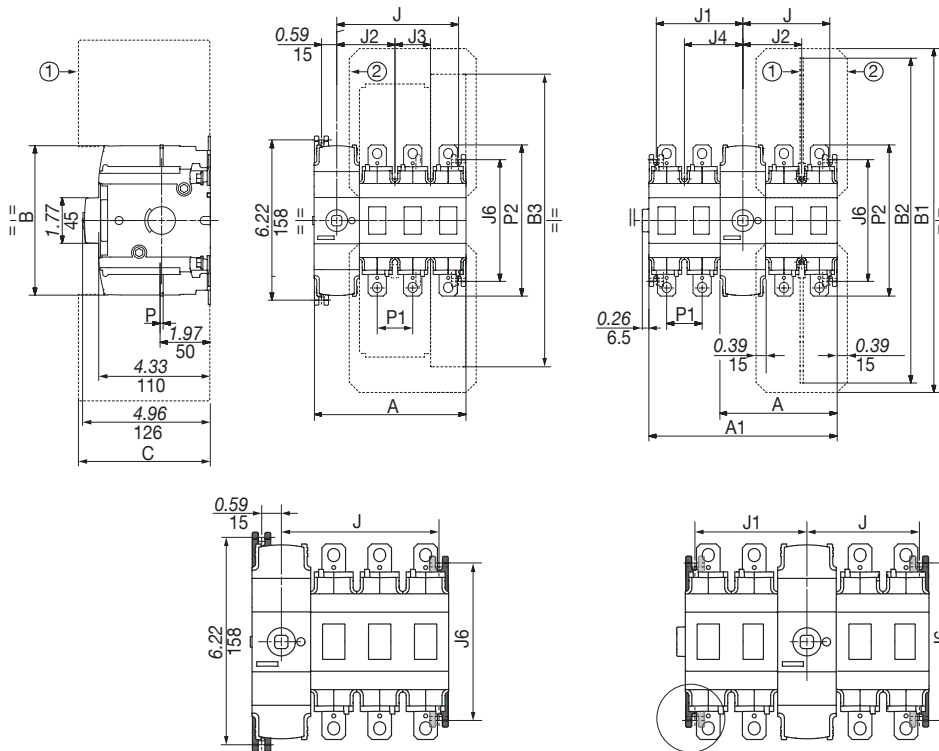

- 1. Inter-phase barrier.
- 2. Terminal screens..

Connection terminal F2

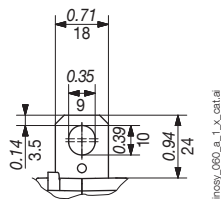

Connection terminal F3

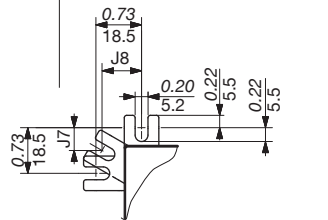
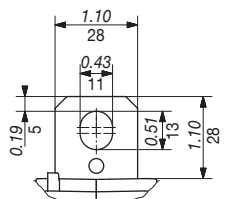

inosys_186_a_1_x_cat.it

Rating (A)	Frame size	Units	A		A1	J	J1	J	
			2 P	3 P	1+1 P / 2+2 P	1+1 P / 2+2 P	1+1 P / 2+2 P	2 P	3 P
100 ... 250	F2	in	4.60	5.98	4.60 / 7.36	1.97 / 3.37	2.05 / 3.44	3.35	4.72
		mm	117	152	117 / 187	50.5 / 85.5	52.5 / 87.5	85.5	120.5
400 ... 1200	F3	in	5.40	7.17	5.40 / 8.94	2.36 / 4.15	2.44 / 4.23	4.13	-
		mm	137	182	137 / 227	60.5 / 105.5	62.5 / 107.5	105.5	-

Rating (A)	Frame size	Units	B	B1	B2		B3	C		J2	J3	J4	J6	P1	P2	
			IEC short	IEC long	UL	IEC	UL									
100 ... 250	F2	in	5.90	13.35	7.85	12.61	10.31	11.64	4.33	4.33	2.26	1.38	2.34	4.72	1.38	5.87
		mm	154	339	199	320	262	296	110	110	57.5	35	59.5	120	35	149
400 ... 1200	F3	in	5.90	16.28	9.35	14.11	15.5	14.12	4.33	5.31	2.64	1.77	2.72	6.22	1.77	7.87
		mm	154	414	237	358	394	359	110	135	67.5	45	69.5	158	45	200

INOSYS LBS UL 98B

Load Break Switches for DC & PV applications
from 100 to 1200 A, up to 1500 VDC

Dimensions for external handles (in/mm)

F2 frame size

Handle type	Front operation Direction of operation	Door drilling
S2 type 		

page_087_a_1_us_calls

F3 frame size

Handle type	Front operation Direction of operation	Door drilling
S2L type 		

page_088_b_1_us_calls

Wiring configuration

1 circuit - 1000 VDC

F2-F3 - 2 P

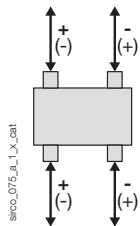

1 circuit - 1500 VDC

F2 - 3P

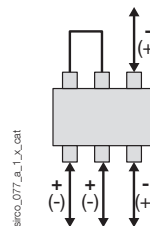

F2-F3 - 2P

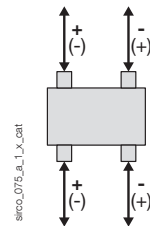

F3 - 2 P // 2P

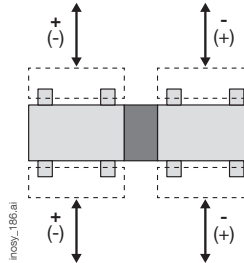

2 circuits - 1500 VDC

F3 - 2 P

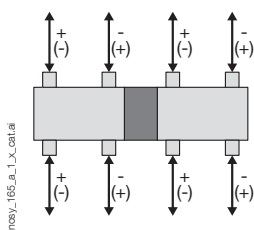

1 circuit - 1500 VDC per polarity

F3 - 2P+2P

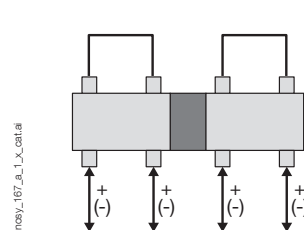

Bridging bars (in/mm)

F2

8409 0016⁽¹⁾

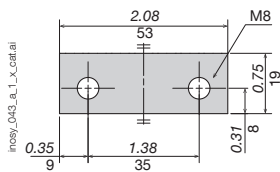

8409 0025

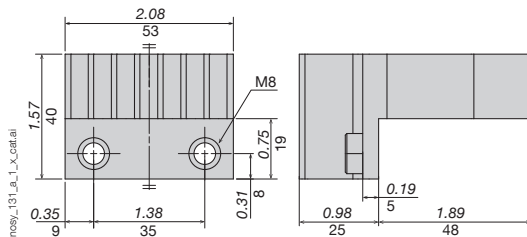

F3

8409 0040⁽¹⁾

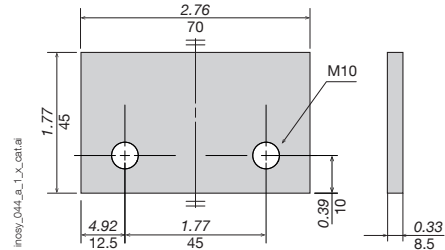

⁽¹⁾ Kit comprises 2 identical bars.

⁽¹⁾ Kit comprises 2 identical bars.

F3

8409 0041

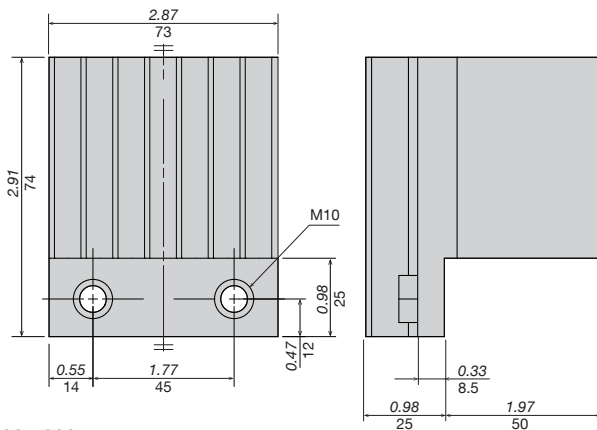

8409 0063

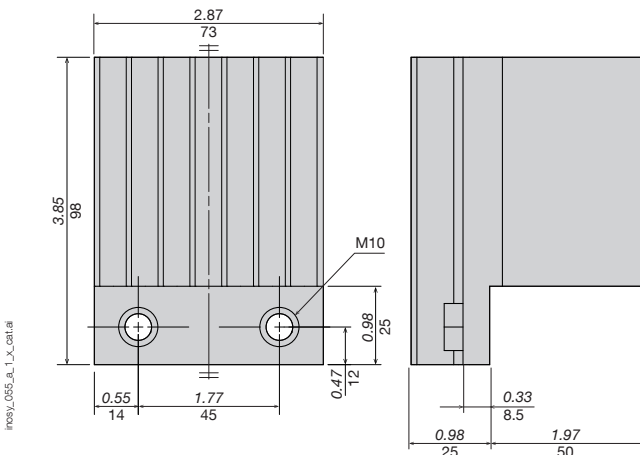

8409 1600

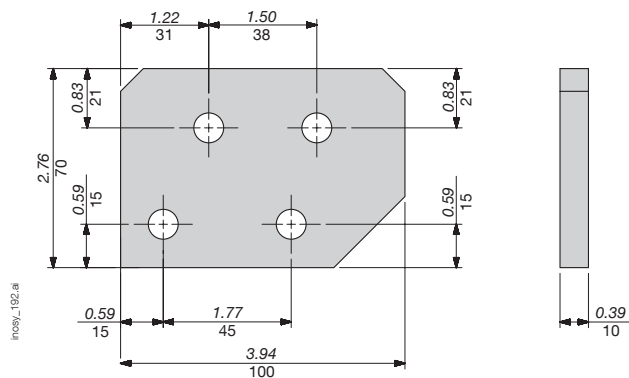

Mounting orientation

F2-F3

All mounting orientations are possible. Derating may apply - please consult us.

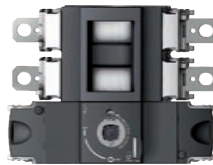

INOSYS ESS

Load Break Switches for DC & ESS applications
from 800 to 1200 A, up to 1500 VDC

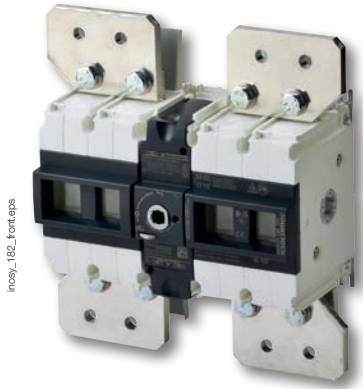

Function

INOSYS ESS LBS is a range of load break switches that can be manually controlled. These switches can be operated manually using the handle to disconnect all or part of the electrical installation. They ensure on-load opening / closing and safe disconnection of any direct current low voltage electrical circuit up to 1500 VDC. They can also be used for emergency power switching applications. They have been specifically designed to withstand high short circuit conditions in ESS applications.

Advantages

High short circuit withstand for DC and ESS applications

INOSYS ESS LBS load break switches have been specifically designed to withstand high short circuit conditions in ESS applications. Tested in both fused and nonfused applications to ensure maximum safety in all fault conditions.

High-performance power switching in a compact frame

INOSYS ESS LBS load break switches incorporate patented technology that provides a breaking capacity of 750 VDC per pole, providing 1500 VDC in just 2 poles, and significantly limiting power dissipation. All in an exceptionally compact device.

Safe & reliable operation

- Direct position indication on the bar and visible contact with containment of the electrical arc.
- The opening and closing of the switch is fully independent from the speed of operation, ensuring safe operation under all conditions.
- High temperature withstand: no derating up to 131 °F (55 °C), functional from -40 to +122 °F (-40 to +50 °C).

General characteristics

- High short circuit withstand for ESS applications.
- Range from 800A to 1200A.
- Up to 1500 VDC.
- High-performance switching in a compact design.
- Easy integration.
- Reinforced safety with visible contact indication.
- Efficient with low power-loss.

Designed for harsh environments

- Vibration testing (from 13.2 to 100 Hz at 0.7 g).
- Shock testing (15 g during three cycles).
- Humid temperature testing (2 cycles, 131 °F/55 °C with 95% humidity level).
- Salt mist testing (3 cycles with humidity storage, 104 °F/40 °C, 93% humidity after each cycle).

Easy to install

- Wiring: as the switch is non-polarized all types of wiring and connections are possible.
- Easy access without tools to integrate auxiliary contacts (located within the switch footprint).
- Mechanism can be centred or left aligned (in the factory) to accommodate installation requirements.

Modular solution for flexible configuration

- Single or dual polarity switching.
- The same switch can be used for installation with either grounded or floating networks by choosing the wiring configuration.

The solution for

- > Energy Storage Inverter
- > Battery Energy Storage Inverter

Strong points

- > High short circuit withstand for ESS applications
- > High-performance power switching in a compact frame
- > Safe & reliable operation
- > Designed for harsh environments
- > Easy to install
- > Modular solution for flexible configuration

Conformity to standards

- > UL 98B
Guide WHVA
File E346418



- > IEC 60947-3,
DC-21B & DC-PV2



- > CCC



Typical applications: local safe disconnection for ESS applications

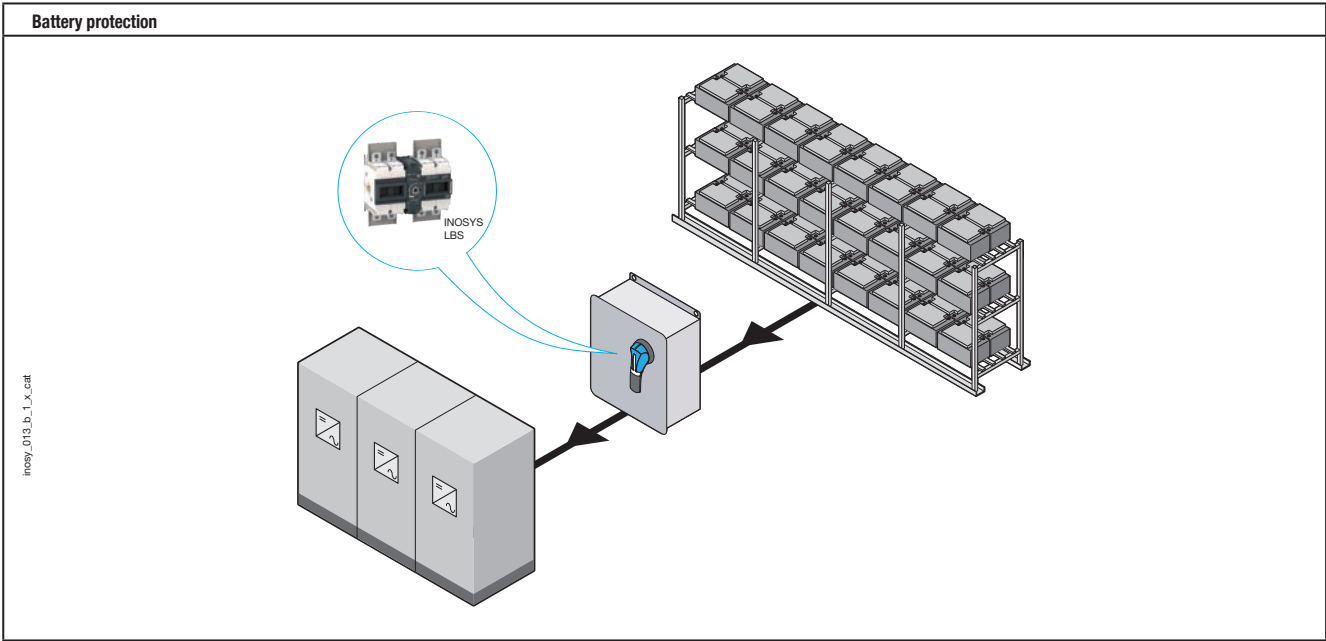

Overview

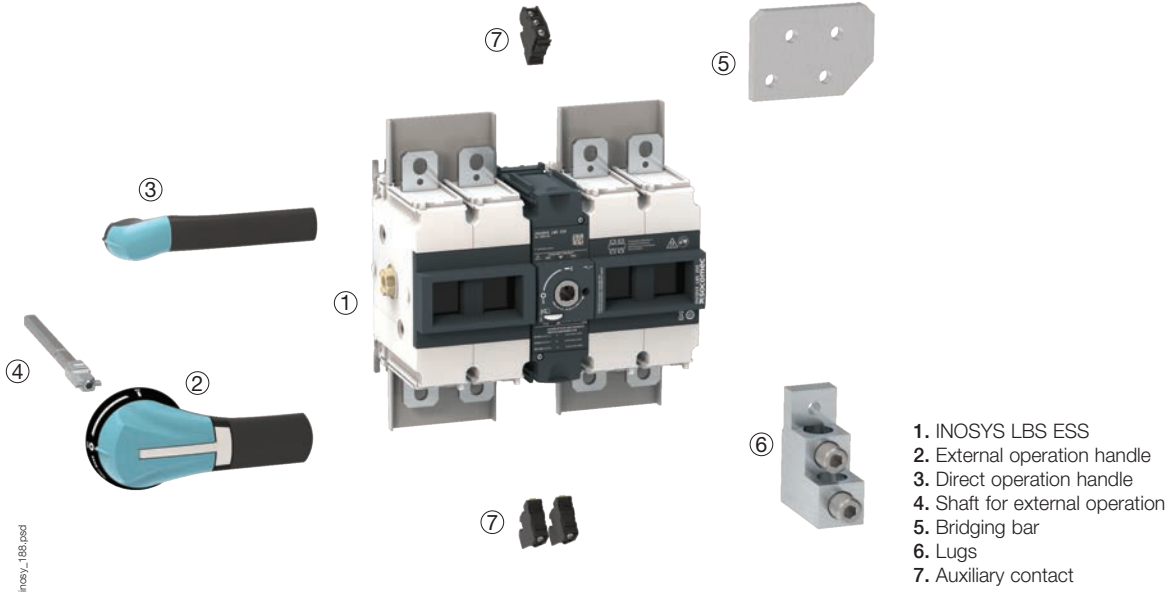

INOSYS ESS

Load Break Switches for DC & ESS applications
from 800 to 1200 A, up to 1500 VDC

References

1500 VDC - high rating

Rating (A)	Frame size	No. of poles per circuit	Switch body ⁽¹⁾	External operation	Aux. Contact	Bridging bar ⁽²⁾
800 A	F3	4P (2P // 2P)	87E2 2081	Shaft 12.6 in / 320 mm 1400 1032 Handle type S2L Black 3R, 12 - 4, 4X 14AD 2111	NO/NC 8499 0001	8409 1600
1000 A			87E2 2100			
1200 A			87E2 2120			

(1) The switches are supplied without accessories.

(2) For isolated networks.

Accessories

Direct operation handle

Frame size	Handle type	Handle colour	Reference
F3	E3	Black	8499 5032



E3 handle

access_400_s_1_cat

Door interlocked external operation handle

Use

Door interlocked external operation handles include an escutcheon and are padlockable. External handles must be utilized with an extension shaft.

Example

As the handle is interlocked in the "ON" position the operator must safely disconnect and isolate the circuit prior to accessing the panel for maintenance procedures.

Opening the door when the switch is in the "ON" position can only be done by defeating the interlocking function with the use of a dedicated tool (authorized personnel only). The interlocking function is restored when the door is re-closed.



S2 type handle

access_150_eps

Frame size	Handle type	Handle colour	Degree of protection	Front operation	Lateral operation
				Reference	Reference ⁽²⁾
F3	S2L ⁽¹⁾	Black	3R,12	14AF 2111	
F3	S2L ⁽¹⁾	Black	4,4X	14AD 2111	14AJ 2111
F3	S2L ⁽¹⁾	Red	4,4X	14AE 2111	

(1) S2L handles have an extended grip; please refer to the dimensions section.

(2) only compatible with left mechanism version.

Shaft for external handle

Frame size	Handle type	Length (in/mm)	Reference
F2 - F3	S2, S2L	7.87/200	1400 1020
F2 - F3	S2, S2L	12.6/320	1400 1032
F2 - F3	S2, S2L	15.75/400	1400 1040

Other lengths: please consult us.



acce_401_a_1_cad

Shaft for S2 and S2L type handle

Isolation plate

Use

This isolation plate ensure safety for the customer.

Characteristics

Products are supplied from factory with isolation plates. For replacement purposes, quantity to order should be 2 kits.



acce_596.eps

Description	Quantity to order	Reference
Isolation plate	2	8499 1000 ⁽¹⁾

(1) Kit includes 2 identical isolation plates

Bridging bar

Use

The bridging bars enable the poles to be connected in parallel, allowing the following configurations for 1500 VDC.

1500 VDC - 1 circuit

Frame Size	Rating (A)	No. of poles	Quantity to be ordered	Reference
F3	800 ... 1200	4P (2P // 2P)	2	8409 1600



acce_590.eps

INOSYS LBS ESS

Load Break Switches for DC & ESS applications
from 800 to 1200 A, up to 1500 VDC

Accessories (continued)

Auxiliary contact

Use

The function of the auxiliary contact depends on where it is mounted on the mechanism.

Characteristics

Changeover type: NO/NC,
IP2X with front operation
(cover tap screwed).
10,000 operations.
Maximum 3 per switch.



access_402_a_1_cat

Frame size	Connection type	Type	Reference
F2 - F3	Screw	NO/NC standard	8499 0001
F2 - F3	Screw	NO/NC standard	8499 0002
F2 - F3	Screw	NC > 600 V	8499 0002

Characteristics

Auxiliary contact type	Min. current (A)	I _{th} (A)	Electrical characteristics per UL 60947-5-1
Standard	12.5 mA / 24 V	10	A300 - R300 - Q150
Low level	1 mA / 4 V	10	A300 - R300 - Q150
> 600 V	10 mA / 24 V	10	A600

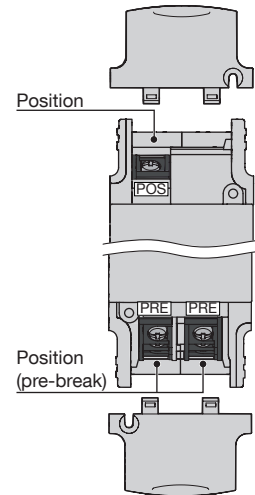

access_465_a_1_gb_cat

Terminal lugs

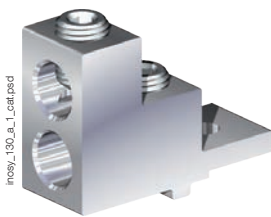

inosy_130_a_1_cat.psd

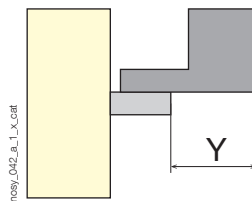

inosy_042_a_1_x_cat

Frame size	Number and size (min. - max.) of cables	Type of cable	Openings per lug	Quantity per reference	Dimension "Y" (mm/in)	Reference ⁽¹⁾
F3	2 conductors (#2 - 600 KCMIL)	Cu / Al	2	2	69.7 / 2.74	3954 2060
F3		Cu / Al		3		3954 3060
F3		Cu / Al		4		3954 4060

Characteristics

Characteristics according to UL 98B

Rated current I_n		800	1000	1200
		(A)	(A)	(A)
Short circuit capacity				
Prospective short-circuit current (kA rms DC) (kA rms)	UL 98B	10	10	10
Mechanical characteristics				
Durability (number of operating cycles)		8000	8000	8000
Short circuit capacity (ESS range)				
Rated conditional short-circuit current I_q (kA rms) ⁽¹⁾	IEC 60947-3, GB/T 14048.3	120kA at (I/r) 0.5ms. 80kA at 3ms.	120kA at (I/r) 0.5ms. 80kA at 3ms.	120kA at (I/r) 0.5ms. 80kA at 3ms.
Connection				
Rigid Cu cable cross-section (mm ²)		4 x 400	4 x 400	4 x 600
Maximum Cu busbar width (mm)		10 x 100	10 x 100	-
Tightening torque min (Nm)		35	35	35
Tightening torque max (Nm)		42	42	42

(1) Tested with fuses. For more information please contact us.

INOSYS ESS

Load Break Switches for DC & ESS applications
from 800 to 1200 A, up to 1500 VDC

Dimensions (in/mm)

INOSYS LBS ESS

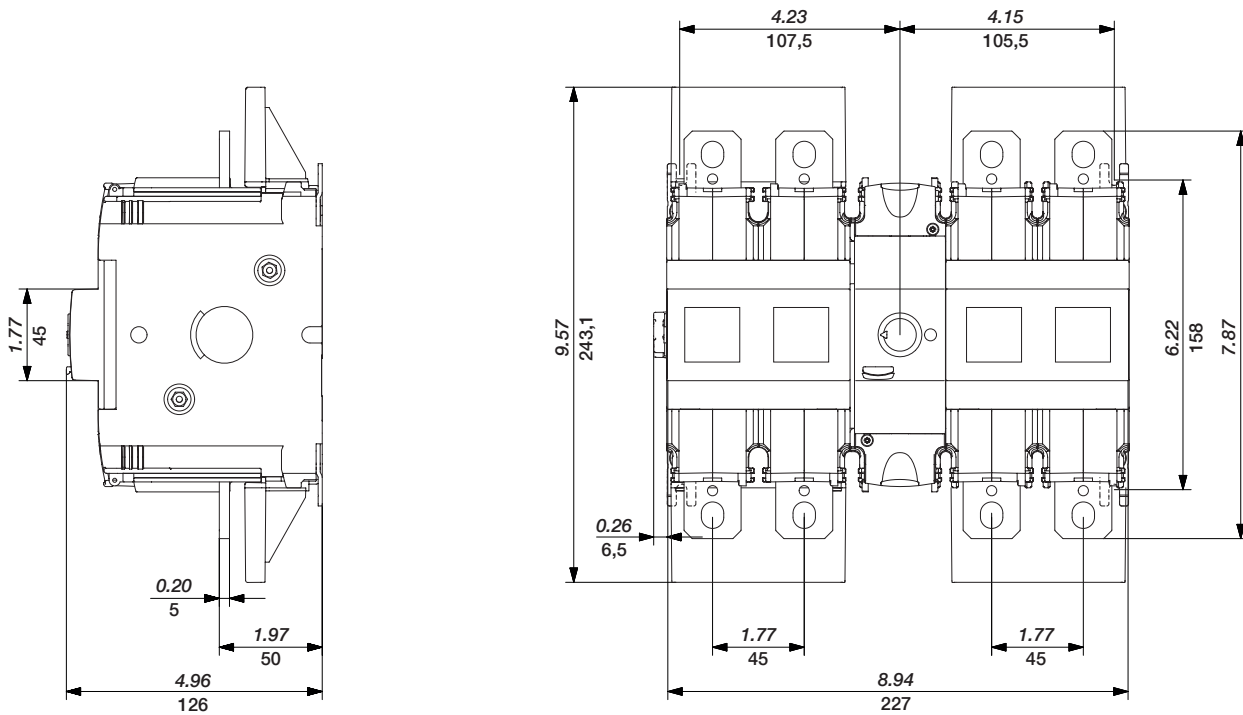

inosy_180.ai

F3 frame size

Dimensions for external handles (in/mm)

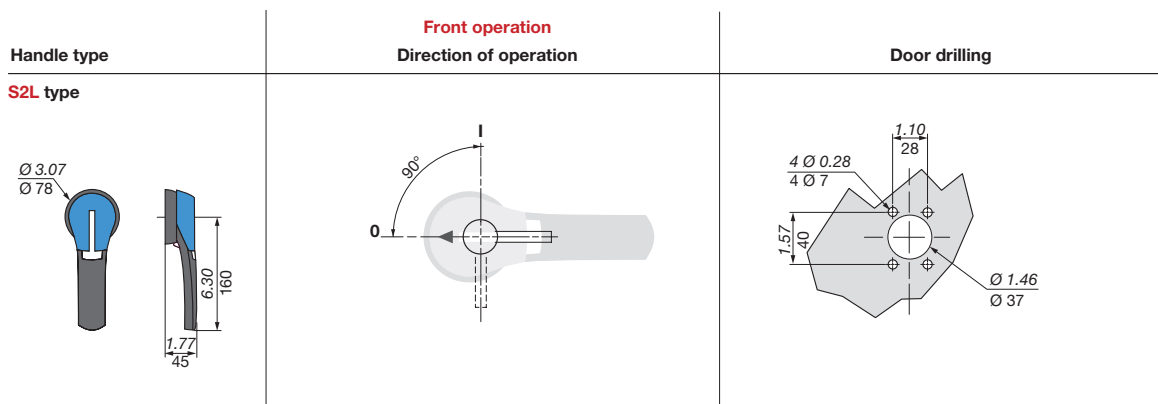

page_069_b_1_us_cat.eps

Bridging bars (in/mm)

F3

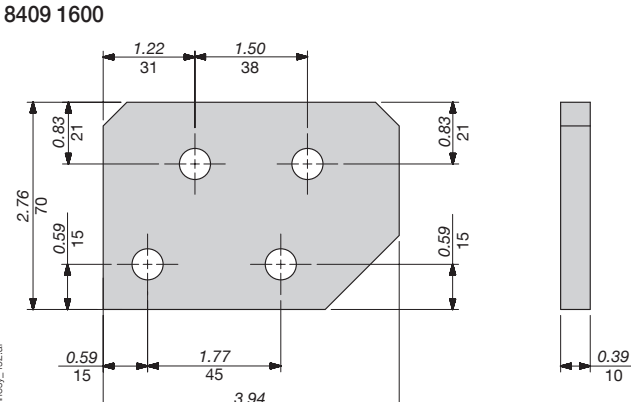

Wiring configuration

1 circuit - 1500 VDC

F3 - 2 P // 2P

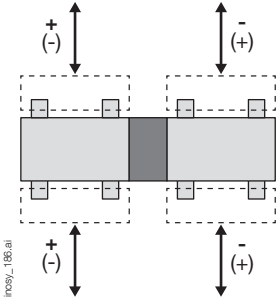

Mounting orientation

F3

Only one mounting operation allowed

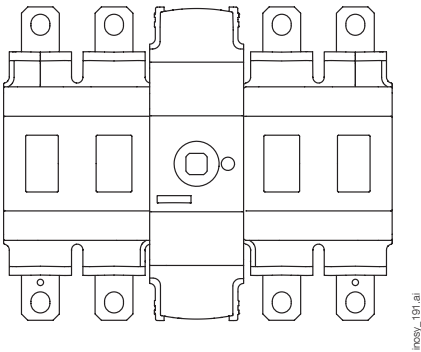

SIRCO MAN and MOT DC / DC ESS

Manual or motorized load break switches for DC applications
2000 A, up to 1500 VDC



SIRCO MAN DC / DC ESS
4 x 2000 A

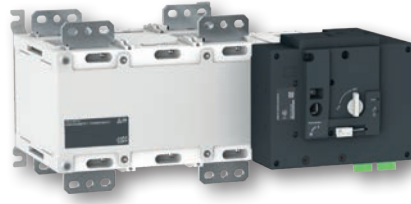

SIRCO MOT DC / DC ESS
4 x 2000 A

Function

SIRCO MAN DC / DC ES are manually operated multipolar load break switches, while **SIRCO MOT DC / DC ESS** are motorized. Both switches make and break under load conditions and provide safety isolation for any low voltage circuit dedicated to DC applications up to 1500 VDC.

Advantages

High performance switching

SIRCO MOT DC and SIRCO MOT DC ESS motorized load break switches incorporate patented technology, providing a breaking capacity at 1500 VDC with just 2 poles, significantly limiting power dissipation.

Application tested design

Designed and tested for several DC applications, with proven performance in the harshest of environments. The arc extinguishing system provides safe disconnection, rapid arc extinguishing and current interruption.

- Tested against high short circuit systems with and without fuse protection to ensure complete system protection above 210 kA.
- Proven against severe environmental factors including: "Annex Q level C according to IEC" salt spray tested, high temperature and altitude, humidity cycle tested.

Reduced total cost of ownership

Developed with user cost savings in mind, the product features improvements which ensure a lower total cost of ownership.

- Flexible wiring configurations allow for simple in and out wiring, and by not using series bridging bars, cost savings can be achieved.
- Compact solution with reduced footprint and weight improves sustainability with reduced packaging, transportation and installation costs.

General characteristics

- Up to 1500 VDC.
- Patented switching technology up to 1500 VDC in 2 poles.
- Remotely operated product (motor control) - SIRCO MOT only.
- 2 stable positions (I, 0).
- High short-circuit option available.

The solution for

- > Photovoltaic inverters and recombiter boxes (PV)
- > Energy Storage System (ESS)
- > Rail Infrastructure
- > Marine Distribution and microgrids
- > Data center



Strong points

- > High performance switching
- > Application tested design
- > Reduced total cost of ownership

Conformity to standards

- > UL 98B
- > IEC 60947-3
- > GB/T 14048.3



SIRCO MAN and MOT DC / DC ESS

Manual or motorized load break switches for DC applications
2000 A, up to 1500 VDC

References

1500 VDC MANUAL

Rating (A) / Frame size	No. of poles No. of circuits	Switch body	Bridging bars for series or parallel pole connection ⁽¹⁾
2000 A / B7ds (UL)	-	27DC 4200	1909 0001

1500 VDC MOTORIZED

Rating (A) / Frame size	No. of poles No. of circuits	Switch body	Bridging bars for series or parallel pole connection ⁽¹⁾
2000 A / B7ds (UL)	-	19DC 4200	1909 0001

1500 VDC ESS MANUAL

Rating (A) / Frame size	No. of poles No. of circuits	Switch body	Bridging bars for series or parallel pole connection ⁽¹⁾
2000 A / B7ds (UL)	-	27ES 4200	1909 0001

1500 VDC ESS MOTORIZED

Rating (A) / Frame size	No. of poles No. of circuits	Switch body	Bridging bars for series or parallel pole connection ⁽¹⁾
2000 A / B7ds (UL)	-	19ES 4200	1909 0001

Accessories

Bridging bars

Use

The bridging bars will easily connect the poles in parallel, allowing the following configurations:

- Bottom/Bottom
- Top/Top

Connection diagrams:

see "Pole parallel connections".

Rating (A) /Frame size	Number of poles of the device in parallel	Pack	Reference
2000 (UL) / B7ds ⁽¹⁾	2	1 piece	reference upon request

(1) UL B7ds requires 4 pcs

Auxiliary contact

Use

Pre-break and signalisation of position I:
1 to 2 NO/NC auxiliary contacts (1 as standard).
Low level auxiliary contacts: please consult us.

Connection to the control circuit

By 6.35 mm fast-on terminal.

Electrical characteristics

30 000 operations.

Characteristics		Operating current I _g (A)			
Rating (A)	Nominal current (A)	250 VAC AC-13	400 VAC AC-13	24 VDC AC-13	48 VDC AC-13
2000	16	12	8	14	6

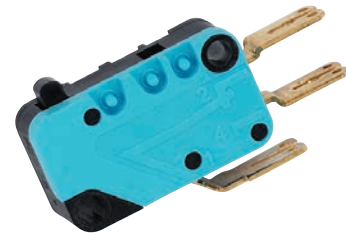

access_005_a_1_cat

References

NO/NC changeover contact

Frame size	Rating (A)	Contact(s)	Reference
B7ds	2000	2 nd	1999 1032



svr_058_a_1_cat

SIRCO MAN and MOT DC / DC ESS

Manual or motorized load break switches for DC applications

2000 A, up to 1500 VDC

Accessories (continued)

2 position padlocking (I - 0)

Use

Enables padlocking in position I (product can be padlocked in position 0 as standard).
Factory fitted.



atys_854_a_1_cat

Frame size	Rating (A)	Reference
B7ds	2000	9599 0004

Key handle interlocking system (motorized version only)

Use

Motorized and manual operations can be locked in position 0 using a RONIS EL11AP lock.

Factory fitted.

As standard, locking in position 0.

Optional padlocking in 2 positions: Locking in position 0 and I.

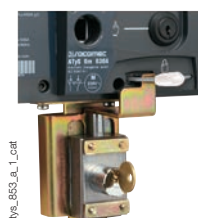

atys_853_a_1_cat

Frame size	Rating (A)	Reference
B7ds	2000	9599 1004

Door protective surround (motorized version only)

Use

When direct access to the SIRCO MOT front face (mode selection, manual operation, display...) is required, the door surround can be utilised to provide a clean and safe finish to the panel's cut-out.

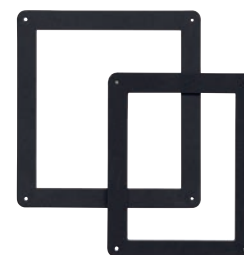

atys_595_a_2_cat

Frame size	Rating (A)	Reference
B7ds	2000	1529 0080

Characteristics according to UL 98B and IEC 60947-3

2000 A at 1500 VDC (B7ds UL)

Thermal current I _{th} at 104°F*			2000
Rated voltage	Utilization category	Ambient temperature (°F)	(A)
1500 VDC	UL 98B	104	2000
* for higher ambient temperature values, consult us			
Short circuit capacity			
Prospective short-circuit current (kA)	UL 98B	-	10
Short circuit capacity (ESS range)			
Rated conditional short-circuit current I _q (kA)	IEC 60947-3, GB/T 14048.3	-	210

SIRCO MAN and MOT DC / DC ESS

Manual or motorized load break switches for DC applications
2000 A, up to 1500 VDC

Dimensions

2000 A / B7ds / 1500 VDC

Dimensions in inch / mm.

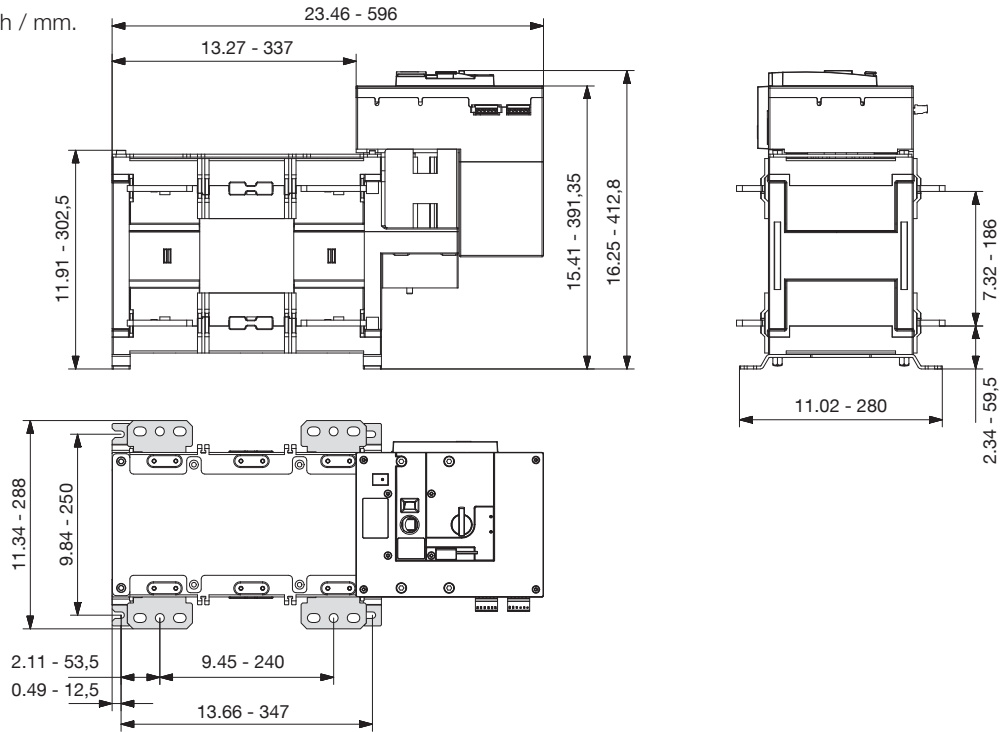

2000 A (1500 V) - UL

Dimensions in inch / mm.

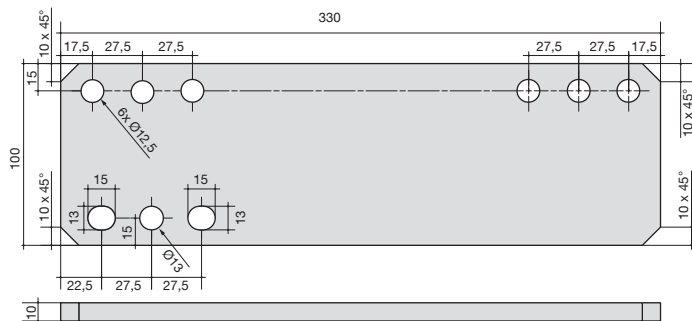

2 + 2 Pole (4 Pole) connections

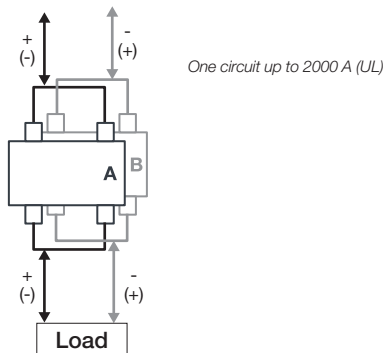

FP ESS

Fuses for energy storage systems
from 160 to 3000 A, up to 1500 VDC



gamme_310.psd

Function

FP ESS fuses are designed specifically for DC networks with high voltage and short circuit levels. They perfectly meet the requirements of energy storage applications and ensure optimal protection of battery racks and battery connection panel (BCP) against short circuits and overloads.

Advantages

Premium performance for energy storage
FP ESS fuses have been specially developed to meet the requirements of Energy Storage applications:

- they are sized for installations with potential short-circuit currents of up to 250 kA and continuous voltages of up to 1500 VDC,
- these fuses offer increased reliability, ensuring consistent performance over time. Their silver-based composition protects them from premature ageing, making them perfectly suited to the cyclic operations characteristic of energy storage application.

A range for a multitude of designs

The FP ESS fuse range covers requirements from 160 to 3000 A, several mounting types and complies with UL, CSA and IEC standards. Combined with the advice of our experts, manufacturers are guaranteed to find the most suitable technical solution by limiting the energy transmitted to the Energy Storage system as much as possible in the event of a fault.

Certified coordination

Combining load break switches with FP ESS fuses enables us to surpass industry standards for protection and safety. Socomec conducts rigorous real-world testing on this combination to push the boundaries of performance and safety even further.

The Solution For

- > Energy
- > Infrastructure & Transport
- > Industry

Strong Points

- > Premium performance for Energy Solution
- > A range for a multitude of designs
- > Certified coordination

Compliance with Standards

- > UL248-13
- > CSA C22.2 NO. 248.1-11
- > IEC 60269-1 /-4

Approvals and certifications⁽¹⁾

- > Combine INOSYS, SIRCOMOT DC ESS Load Break Switches and FP ESS fuses to achieve a level of protection and safety above market standards

The building blocks of an energy storage system

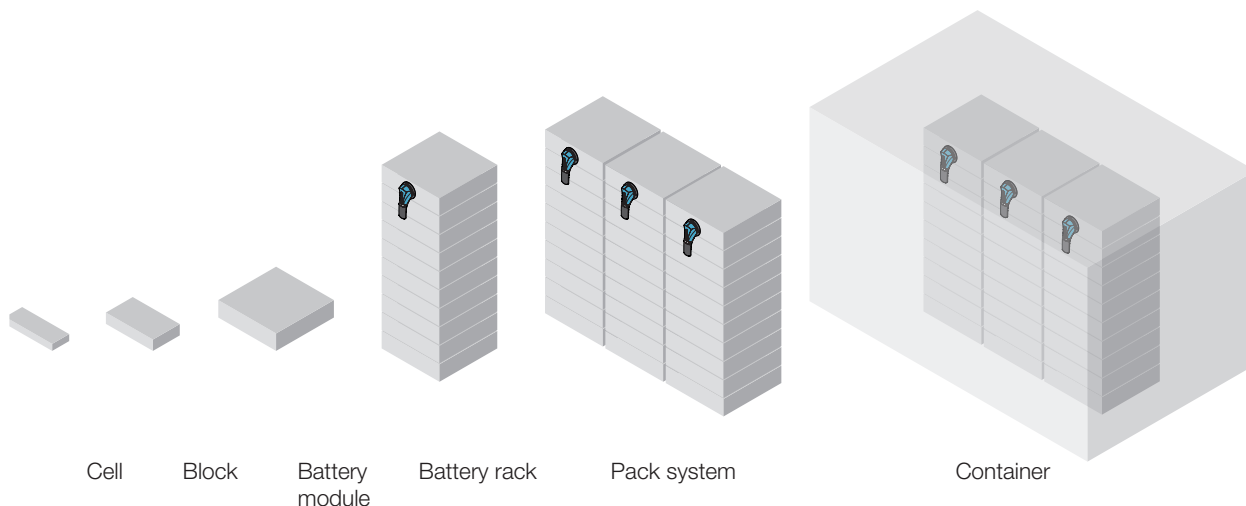

Rack construction

Cells: serial connection to increase ampacity

- Cells are connected in serial to create blocks.
- Blocks are connected together into the battery module.
- Battery rack contains several battery modules and includes switch and fuse protection.

System construction

Modules: parallel connection to reach a higher voltage

- Modules are connected together in parallel to reach a higher voltage (1000 VDC to 1500 VDC).
- Battery systems, pack system and containers are connected in parallel to increase ampacity.

Typical energy storage architecture

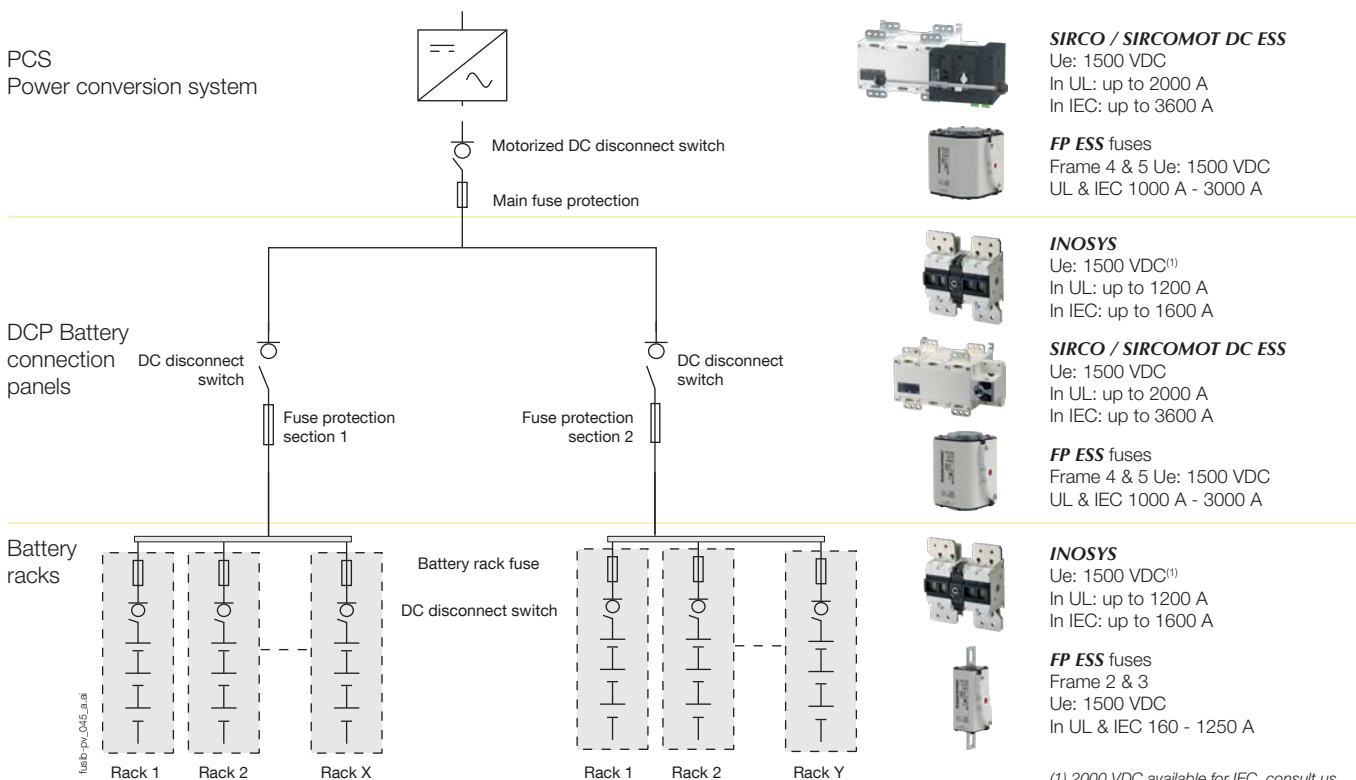

FP ESS

Fuses for energy storage system
from 160 to 3000 A, up to 1500 VDC

References

Frame 2

Rating (A)	DIN	Reference		Rated voltage (VDC)	Breaking capacity (kA)	I ² t (A.s ²)		Power loss (W)			Standard Package Quantity
		Bolted	Flush			Pre-arcing	Total	100% rated	80% rated	60% rated	
160	61S1 2016	61S2 2016	61S3 2016	1500	250	4850	12150	81	52	29	8
200	61S1 2020	61S2 2020	61S3 2020	1500	250	12900	32508	90	58	32	8
250	61S1 2025	61S2 2025	61S3 2025	1500	250	20667	52702	113	72	41	8
280	61S1 2028	61S2 2028	61S3 2028	1500	250	24704	63737	125	80	45	8
315	61S1 2032	61S2 2032	61S3 2032	1500	250	34406	89799	134	86	48	8
350	61S1 2035	61S2 2035	61S3 2035	1500	250	45240	119433	143	92	51	8
400	61S1 2040	61S2 2040	61S3 2040	1500	250	64361	171844	159	102	57	8
450	61S1 2045	61S2 2045	61S3 2045	1500	250	85836	231757	169	108	61	8
500	61S1 3050	61S2 3050	61S3 3050	1500	250	109226	298187	183	117	66	8
550	61S1 3055	61S2 3055	61S3 3055	1500	250	134094	370099	204	131	73	8
630	61S1 2063	61S2 2063	61S3 2063	1500	250	194817	543539	213	136	77	8
700	61S1 2070	61S2 2070	61S3 2070	1500	250	263007	741680	236	152	85	8
800	61S1 2080	61S2 2080	61S3 2080	1500	250	389471	1109993	253	162	91	8

Frame 3

Rating (A)	DIN	Reference		Rated voltage (VDC)	Breaking capacity (kA)	I ² t (A.s ²)		Power loss (W)			Standard Package Quantity
		Bolted	Flush			Pre-arcing	Total	100% rated	80% rated	60% rated	
315	61S1 3032	61S2 3032	61S3 2032	1500	250	21132	76076	130	83	47	6
350	61S1 3035	61S2 3035	61S3 2035	1500	250	29035	103654	141	90	51	6
400	61S1 3040	61S2 3040	61S3 2040	1500	250	38277	134736	163	104	59	6
450	61S1 3045	61S2 3045	61S3 2045	1500	250	54477	189034	178	114	64	6
500	61S1 3050	61S2 3050	61S3 2050	1500	250	73708	254293	194	124	70	6
550	61S1 3055	61S2 3055	61S3 2055	1500	250	92243	310858	211	135	76	6
630	61S1 3063	61S2 3063	61S3 2063	1500	250	130404	429029	236	151	85	6
700	61S1 3070	61S2 3070	61S3 3070	1500	250	180048	582330	257	164	92	6
800	61S1 3080	61S2 3080	61S3 2080	1500	250	280849	876249	268	172	96	6
900	61S1 3090	61S2 3090	61S3 3090	1500	250	404951	1222952	288	184	104	6
1000	61S1 2063	61S2 3100	61S3 2063	1500	250	544267	1589259	338	216	122	6
1100	61S1 3110	61S2 3110	61S3 3110	1500	250	747801	2108800	348	222	125	6
1200	61S1 3120	61S2 3120	61S3 2080	1500	250	1011651	2751692	359	230	129	6

Frame 4

Rating (A)	Reference		Rated voltage (VDC)	Breaking capacity (kA)	I ² t (A.s ²)		Power loss (W)			Standard Package Quantity
		Flush			Pre-arcing	Total	100% rated	80% rated	60% rated	
630		61S3 4063	1500	250	5559	515387	185	118	67	2
700		61S3 4070	1500	250	62908	550508	196	125	71	2
800		61S3 4080	1500	250	93198	589702	205	131	74	2
900		61S3 4090	1500	250	145288	892272	209	134	75	2
1000		61S3 4100	1500	250	214409	1293639	213	136	77	2
1100		61S3 4110	1500	250	265180	1506364	238	152	86	2
1250		61S3 4125	1500	250	368330	2275447	248	159	89	2
1500		61S3 4150	1500	250	622427	3748158	296	189	107	2
1600		61S3 4160	1500	250	758300	4501500	294	188	106	2
1800		61S3 4180	1500	250	1050000	6320000	325	208	117	2

References (cont...)

Frame 5

Rating (A)	Reference Flush	Rated voltage (VDC)	Breaking capacity (kA)	I ² t (A.s ²)		Power loss (W)			Standard Package Quantity
				Pre-arcing	Total	100% rated	80% rated	60% rated	
1250	61S3 5125	1500	250	366800	1310300	270	173	97	1
1350	61S3 5135	1500	250	501700	1810800	290	186	104	1
1500	61S3 5150	1500	250	749900	2678900	300	192	108	1
1800	61S3 5180	1500	250	1145200	4091100	330	211	119	1
2000	61S3 5200	1500	250	1557700	5925300	380	243	137	1
2200	61S3 5220	1500	250	2030000	7470000	430	275	155	1
2500	61S3 5250	1500	250	2955000	12680000	440	282	158	1
2800	61S3 5280	1500	250	4175000	17057000	460	294	166	1
3000	61S3 5300	1500	250	5480000	19600000	600	384	216	1

Accessories

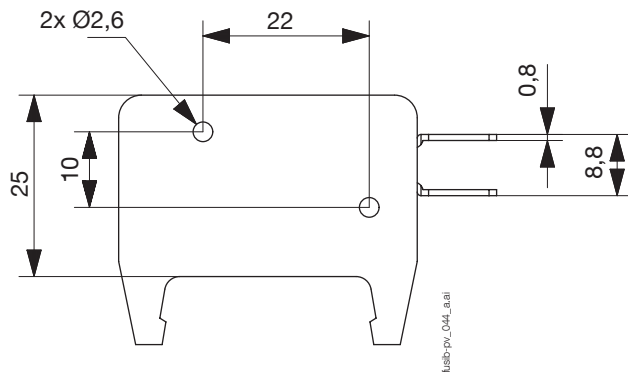

Reference	Contact	Electrical performances
61S0 0001	1NO + 1NC	250 VDC 2 A

FP ESS

Fuses for energy storage system
from 160 to 3000 A, up to 1500 VDC

Features

Time/current operation

Frame 2

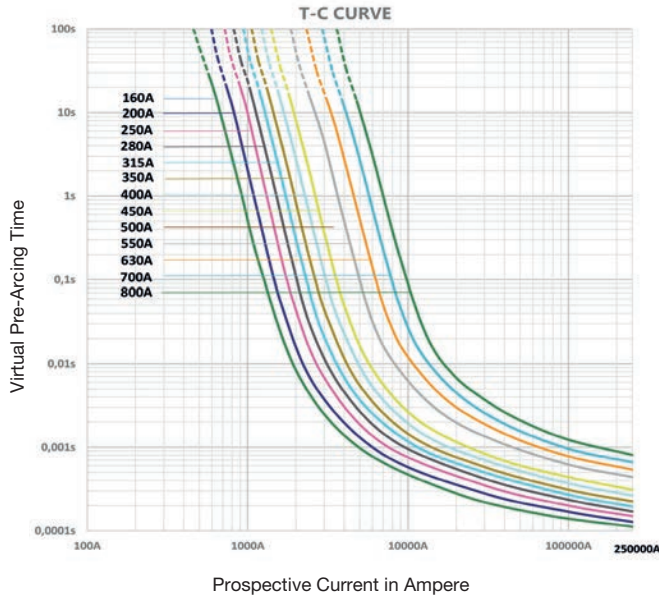

Frame 3

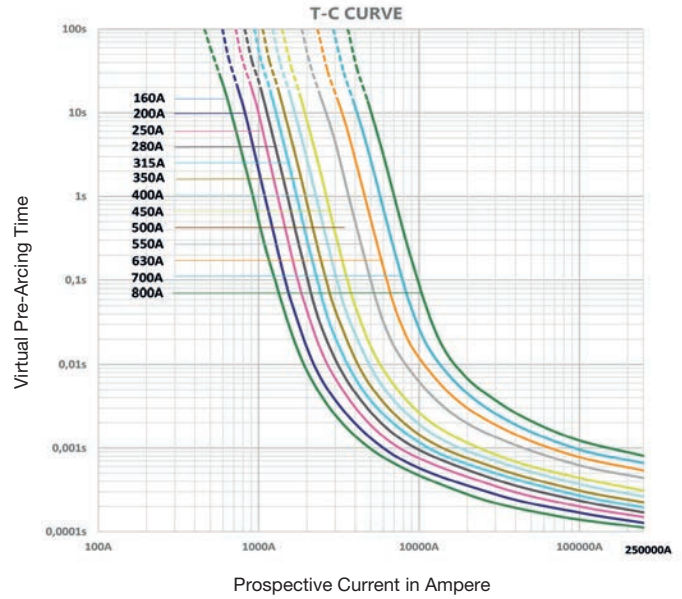

Frame 4

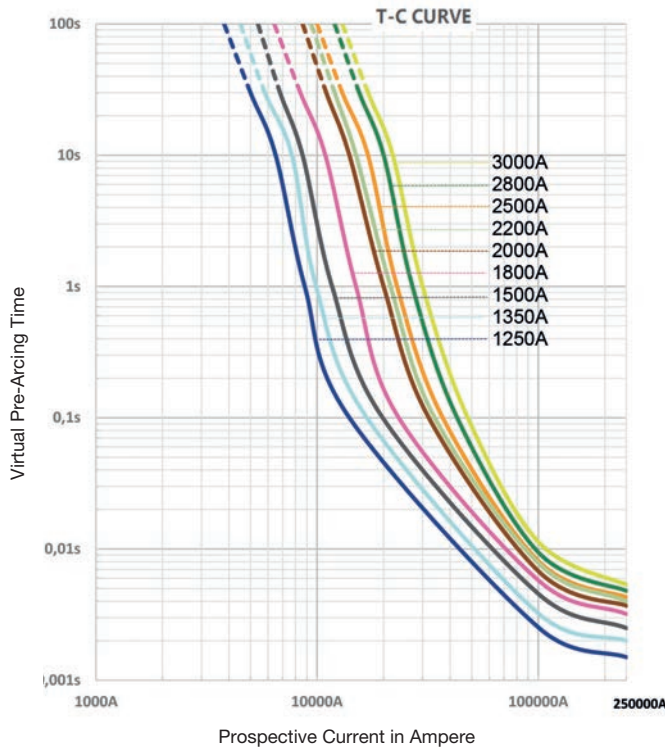

Frame 5

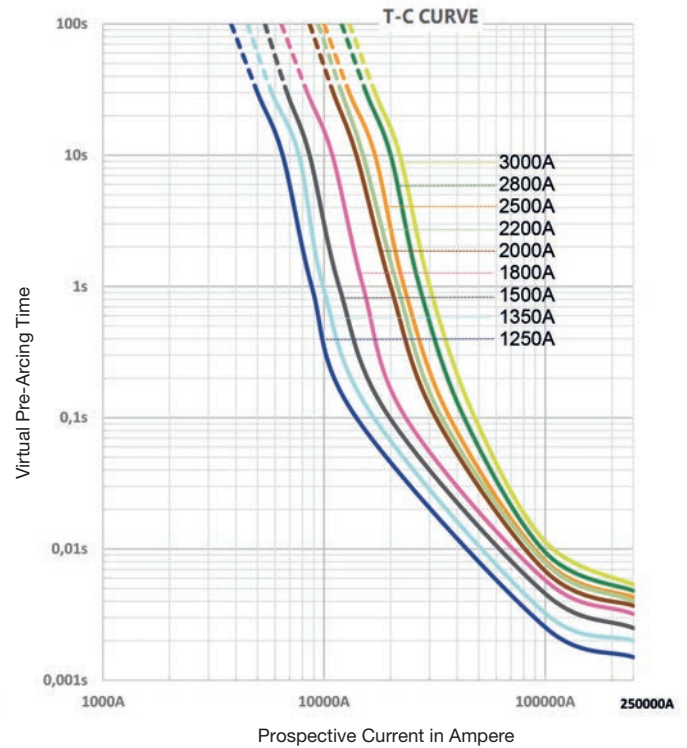

Temperature correction curve

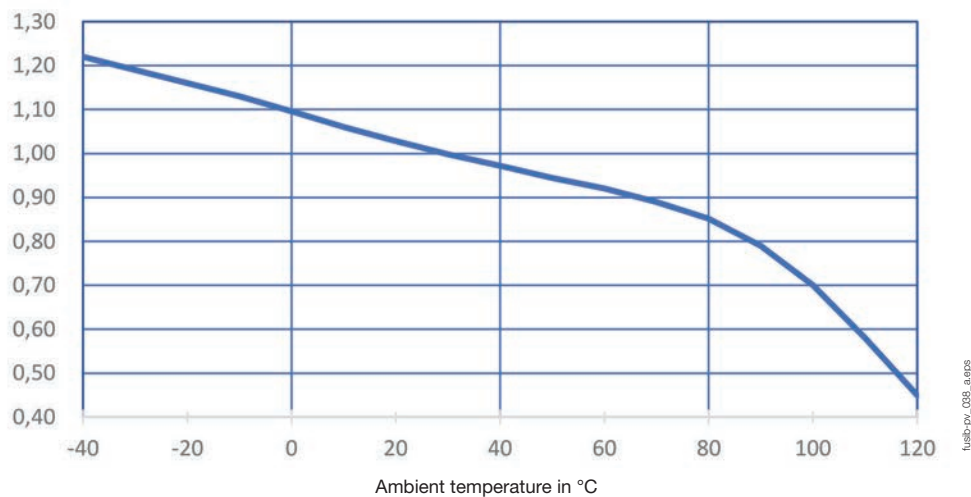

FP ESS

Fuses for energy storage system
from 160 to 3000 A, up to 1500 VDC

Dimensions (in/mm)

Flush mount

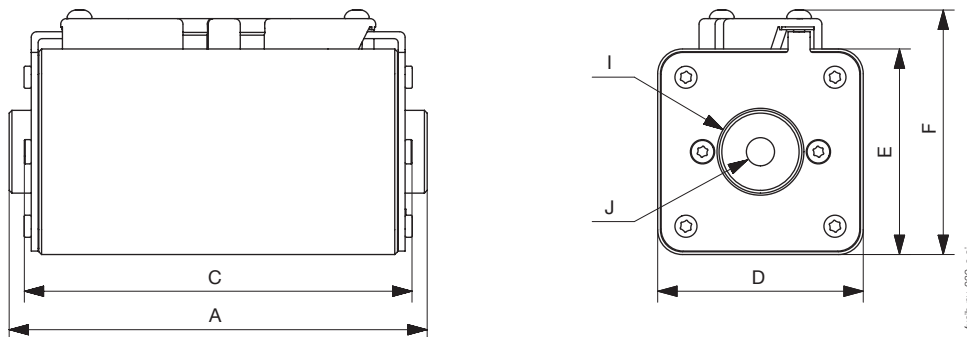

	A		C		D		E		F		I		J
	in	mm	in	mm	in	mm	in	mm	in	mm	in	mm	Bolt
Frame 2	5.96	152	5.50	140	2.33	59.2	2.33	59.2	3.03	77	0.94	24	M10
Frame 3	5.96	152	5.50	140	2.93	74.5	2.93	74.5	3.62	92	1.18	30	M12

Bolted mount

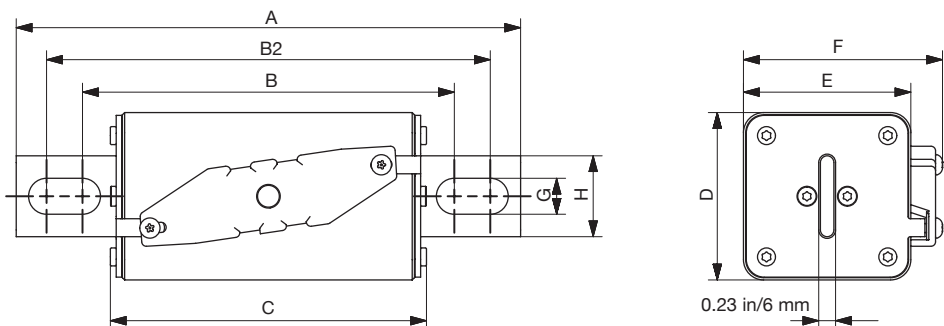

	A		B		B2		C		D		E		F		G		H	
	in	mm	in	mm	in	mm	in	mm	in	mm	in	mm	in	mm	in	mm	in	mm
Frame 2	8.76	222.5	6.59	168	7.78	198	5.50	140	2.33	59.2	2.33	59.2	3.03	77	0.55	14	1.10	28
Frame 3	8.84	224.5	6.52	166	7.78	198	5.54	141	2.93	74.5	2.93	74.5	3.62	92	0.63	16	1.42	36

DIN mount

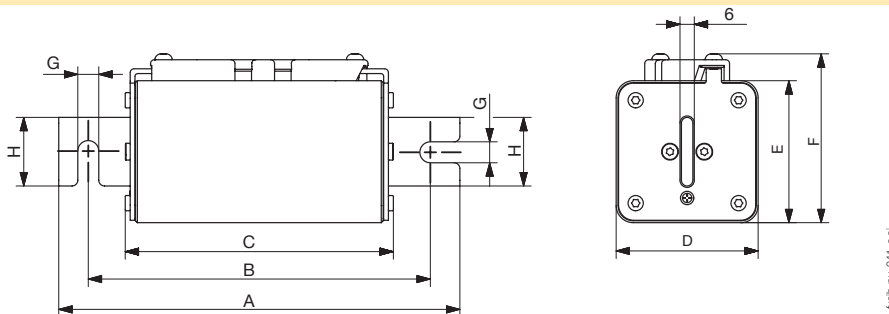

	A		B		C		D		E		F		G		H	
	in	mm	in	mm	in	mm	in	mm	in	mm	in	mm	in	mm	in	mm
Frame 2	8.29	211	7.07	180	5.50	140	2.33	59.2	2.33	59.2	3.03	77	0.43	11	1.10	28
Frame 3	8.29	211	7.07	180	5.54	141	2.93	74.5	2.93	74.5	3.62	92	0.34	11	1.42	36

Dimensions (in/mm)

Flush mount

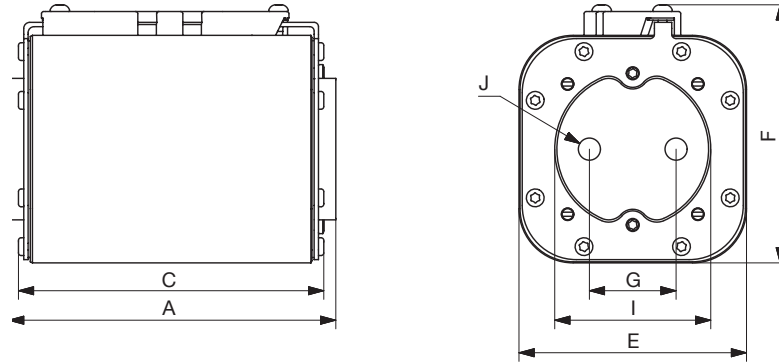

fusib-pv_042_a.ai

Frame 4	A		C		E		F		G		I		J
	in	mm	in	mm	in	mm	in	mm	in	mm	in	mm	Bolt
	5.98	152	5.55	141	5.92	150	4.76	121	1.57	40	2.76	70	M10

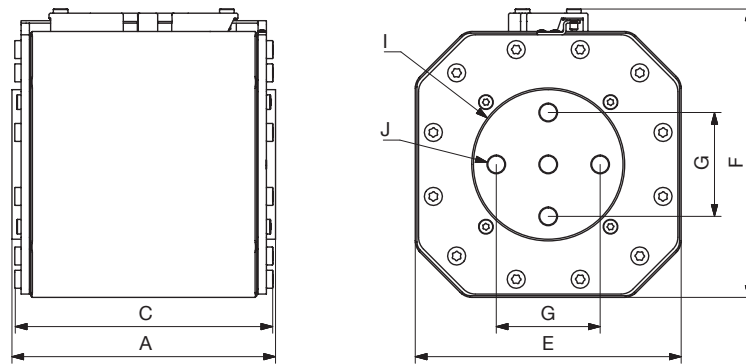

fusib-pv_043_a.ai

Frame 5	A		C		E		F		G		I		J
	in	mm	in	mm	in	mm	in	mm	in	mm	in	mm	Bolt
	6.26	159	6.10	155	6.22	158	6.22	158	2.46	62.5	3.54	90	M12

Accessories

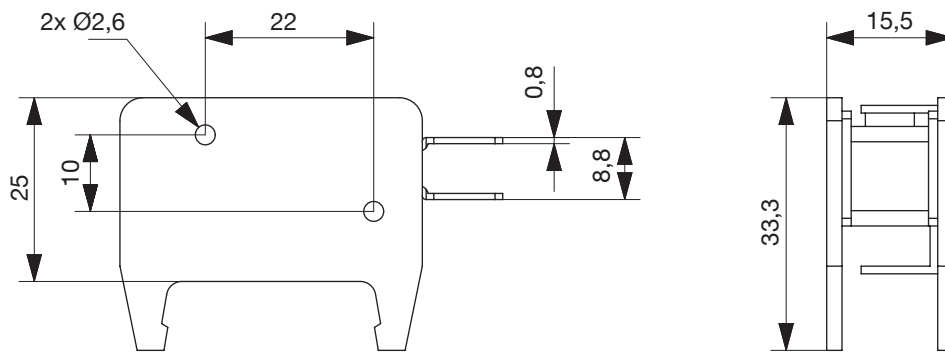

fusib-pv_044_a.ai

Electrical performances	Contact	Reference
250 VDC 2 A	1NO + 1NC	61S0 0001



Fusible Disconnect Switches

Fuse Solutions: Definite advantages over circuit breakers p. 92

Fusible Disconnect Switches



FUSERBLOC UL
30 to 800 A
p. 94



FUSERBLOC DRIVE 1PP
600 to 1700 A
p. 110

Modular Fuse Holders



RM CC
Class CC
30 A
p. 118



RM - RMS
for Midget / Ferrule fuses
32 to 125 A
p. 122

Specific Products

Fuse combination switches for specific applications.
p. 128



Fuse Solutions: Definite Advantages Over Circuit Breakers

Fuses: High Performance

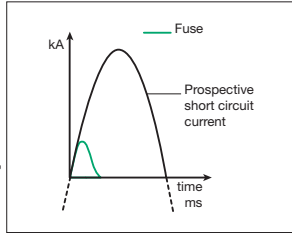

Due to the high current limiting CC, J and L type fuses, the best protection will be provided to downstream components, such as motor or motor starter. Our disconnects have been designed around this concept to provide 200 kA as a SCCR on most of the range.

Safety

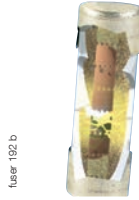

The energy released during a short-circuit is contained in the sealed fuse cartridge. There is no release of ionized gases, thus no effect on surrounding equipment in comparison to what happens when circuit-breakers open during a short-circuit event.

Circuit-Breakers: Reduced Breaking Capacity

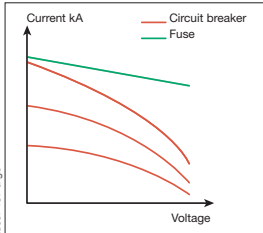

The breaking capacity of circuit-breakers reduces dramatically when voltage increases: capacity can decrease from 100 kA at 240 V to 20 kA or even less at 600 V.

Reliability Over Time

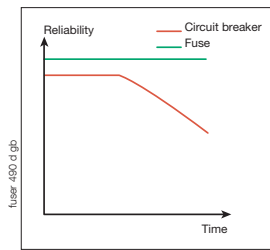

Fuses are totally sealed products, which guarantee long-term protection without any maintenance.

Circuit-Breakers are complex devices with moving parts. Their performance is affected by dust and humidity, and needs maintenance.

Re-Close or Replace ?



Circuit-breakers can be re-closed after a fault: their manufacturers' biggest selling point.

You should however consider that the circuit-breaker should be inspected each time there is a significant short-circuit. It is hard to know how many times a circuit-breaker has operated.

In contrast, when a fuse blows, it is replaced by a new one, and the installation is as reliable as prior to the fault.

Thus, re-close or replace ?

Longer Lasting

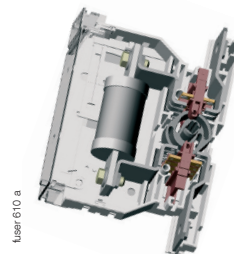

Our FUSERBLOC has 2 separate design functionalities:

- magneto-thermal protection, made inside the encapsulated fuses
- disconnection thru moving contacts

that stay closed during short-circuit (arc won't destroy them)

- On a circuit-breaker both functionalities are on the same mechanical

Evolution of NEC® Regulation

Requirement of Panel SCCR Art 409 of NEC® 2005 & UL 508A

According to NEC® 2005, all industrial control panels must be marked with a Short-Circuit Current Rating (SCCR).

This covers the entire panel and not just the primary rating of the over-current protection device, as commonly done before.

Calculation of the panel's SCCR is easy with a fuse disconnect switch, since there is a defined table SB4.1 in UL 508 which specifies I_p (peak value) of feeder fuse that can be used for protection of downstream components, which is not the case for circuit-breakers. Thanks to the high current limiting characteristics of the fuses the SCCR of branch circuits can be highly enhanced.

Arc Flash NEC®2005

The NEC now has requirements related to arc flash hazards. Section 110-16, Flash Protection, requires markings on switchboards, panel boards, industrial control panels and motor control centers to warn from potential arc flash hazards. Arc flash mitigation is greatly enhanced by the use of fuses and their current limiting capabilities and fast opening times.

UL/CSA Standards for Disconnect Switches

UL 98 - Enclosed and Dead Front Switches (equivalent to CSA-C22.2 no 4)

These requirements cover enclosed or dead front switches, with or without provision for fuses, at 600 volts or less.

These products are used as disconnecting means without restrictions; they are heavy duty products requiring 2 inches (50 mm) minimum of creepage distance, which gives maximum safety for users and installation. The short circuit withstand of those products goes up to 200 kA.

UL 489 - Molded Case Switches (equivalent to CSA-C22.2 no 5)

These requirements cover molded-case circuit Breaker, molded case switches and fused molded-case switches, rated at 600 volts or less and 6,000 amperes or less.

Typical Control Panel



UL Standards for Electrical Machinery

UL 508 - Industrial Control Equipment (equivalent to CSA-C22.2 no 14)

These requirements cover manual, magnetic and solidstate starters and controllers, overload relays, pushbuttons, selector switches, and control lights.

These are IEC type products, requiring only a creepage distance between phases of 1/2 inch. UL 508 standard requested only 5 kA or 10 kA as short circuit withstand with fuse protection. Their use as a disconnecting mean is therefore limited to local disconnection of motors. These products can only be used as a disconnect means when they have been additionally tested "suitable as motor disconnect". This additional testing ensures that the switch has a proper closing capacity on short circuit faults. UL 508 (switches or circuit breakers) can not be used as the main disconnect of an electrical panel (i.e. in entrance of control panels).

A manual motor controller marked "suitable as motor disconnect" shall be installed only on the load side of the branch circuit protective device (UL 508A 30.3.3 and NEC 430.109(6)).

NFPA 79 Electrical Standard for Industrial Machinery

The following types of machines are identified as industrial machinery:

- metalworking machine tools, including machines that cut or form metal
- plastics machinery
- wood machinery, including woodworking, laminating, and sawmill machines
- assembly machines
- material handling machines, including industrial robots and transfer machines
- inspection and testing machines, including coordinate measuring and in-process gauging machines

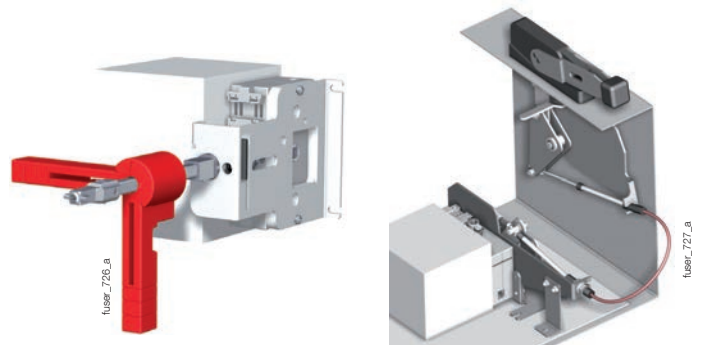

FUSERBLOC UL

Fusible disconnect switches
from 30 to 800 A



The solution for data centers

- > Data center
- > Healthcare
- > Industry
- > Building



Strong points

- > Improved safety
- > High breaking capacity
- > Multi-use
- > Simplified use

Conformity to standards⁽¹⁾

- > UL489 (box 1 and 2)
- > UL 98 (box 4 to 8)
- > CSA 22.2 #4 (frame 1 and 2)
- > CSA 22.2 #5 (frame 4 to 8)
- > NFPA 79 (2002 version)



Enclosures

- > Enclosed fusible disconnect switch available



celful_C02.pdf

Function

FUSERBLOC UL units are manually-operated multipole fusible disconnect switches with the external right front-side operation and comply with UL and CSA standards.

They provide make-and-break on load, safety isolation, and protection against overcurrent for any low-voltage electrical circuit. The switches use double-pole isolator contacts to ensure complete fuse isolation when the switch is in the "OFF" position.

These devices are suitable for use as disconnectors for motors and industrial control panels on service entrance equipment, final panelboards, distribution switchboards, industrial control equipment or motor control centers.

This range is available in right front-side, direct or external control, in 2, 3 and 4 poles and up to 800 A.

Advantages

Improved safety

The double-phase isolator (upstream-downstream of the fuse) and fully visible isolation guarantees the safety of people and equipment against overcurrents.

High breaking capacity

High breaking capacity fuses (200 kA rms) provide protection against overloads and shortcircuits.

Multi-use

The device can be equipped with a "Flange" type front or side operation handles, fitted directly on the product or externally, possibly installed on the door or the side of the electrical box or cabinet. The device is also equipped with voltage measurement terminals for taking measurements and an NFPA 79 compliance kit available as an option.

Simplified use

The TEST position enables testing of the control circuits without turning on the power, thanks to U-type auxiliary contacts. In the TEST position, the cabinet door can be opened.

General characteristics

- For fuses up to 800 A.
- Up to 200 kA.
- AC voltage from 208 V to 600 V.
- Accepts Class CC, J, L and T-fuses.
- 2P, 3P or 4P available.

References

Fusible disconnect

Rating (A) Fuses Frame size	No. of poles	Switch body	Direct handle	Front external handle	External right side handle ⁽¹⁾	Shaft external handle	NFPA79 kit	U-type auxiliary contacts	Terminal shrouds	
CD 30 A CC 1	3 P	3710 3003	Black 3729 4012	S0 type Black I - 0 1, 3R, 12 1493 0111 4, 4X 149D 0111		S0 type 200 mm 7.9 inches 1405 0620	3729 4532 ⁽²⁾			
	3 P + switched neutral	3710 4003				320 mm 12.6 inches 1405 0632				
	3 P + solid neutral	3710 5003				400 mm 15.7 inches 1405 0640				
CD 30 A J 2	3 P	3710 3004	3729 4014	S1 type Black I - 0 1, 3R, 12 141F 2111 4, 4X 141D 2111		S1 type 200 mm 7.9 inches 1401 0520		1 contact NO 3999 0701 1 contact NC 3999 0702	not required	
	3 P + switched neutral	3710 4004				320 mm 12.6 inches 1401 0532				
	3 P + solid neutral	3710 5004				400 mm 15.7 inches 1401 0540				
30 A J 4	2 P	3861 2004	Black 3629 7910	S1 type Black I - 0 1, 3R, 12 Defeatable 141F 2111	S1 type Black I - 0 4, 4X 141H 6111	S1 type 200 mm 7.9 inches 1400 1020	3729 7540			
	3 P	3861 3004								
	4 P	3861 6004								
60 A J 4	2 P	3861 2005		I - 0 4, 4X Defeatable 141D 2111 I - 0 - Test 4, 4X Defeatable 141D 2115	S1 type Red / yellow I - 0 4, 4X 141I 6111	320 mm 12.6 inches 1400 1032				
	3 P	3861 3005				400 mm 15.7 inches 1400 1040				
	4 P	3861 6005								

Common accessories - more available on next pages.

(1) No door interlocking.

(2) Please use with S1 handle

FUSERBLOC UL

Fusible Disconnect Switches UL and CSA
from 30 to 800 A

References (continued)

Fusible Disconnect Switches

Rating (A) fuses Frame size	No. of poles	Switch body	Direct handle	Front external handles	External right side handle ⁽¹⁾	Shaft for external handle	NFPA79 kit	U-type auxiliary contacts	Terminal shrouds																		
60 A J 5	2 P	3861 2006	Black 3629 7910	S2 type Black 1 - 0	S2 type Black 1 - 0	S2 type	3729 7540	1 contact type NO 3999 0701 1 contact type NC 3999 0702	not required																		
	3 P	3861 3006																									
	4 P	3861 6006																									
100 A J 5	2 P	3861 2010 ⁽²⁾							Black 3629 7910	S2 type Black 1 - 0	S2 type Black 1 - 0	S2 type	3729 7540	1 contact type NO 3999 0701 1 contact type NC 3999 0702	not available												
	3 P	3861 3010 ⁽²⁾													not required												
	4 P	3861 6010 ⁽²⁾													3898 2020												
200 A J 6	2 P	3861 2020													Black 3629 7910	1, 3R, 12 Defeatable 142F 2111	4, 4X 142H 6111	320 mm 12.6 inches 1400 1032	3729 7544	1 contact type NO 3999 0701 1 contact type NC 3999 0702	3898 3020						
	3 P	3861 3020																			3898 3020						
	4 P	3861 6020																			3898 4020						
400 A J 7	2 P	3851 2038																			Black 3629 7910	4, 4X Defeatable 142D 2111	Red / yellow 1 - 0	400 mm 15.7 inches 1400 1040	3729 7544	1 contact type NO 3999 0701 1 contact type NC 3999 0702	3898 2040
	3 P	3851 3038																									3898 3040
	4 P	3851 6038																									3898 6040
600 A J 8	2 P	3850 2060	Black 3859 6011	S3 type Black 1 - 0	S3 type	200 mm 7.9 inches 1400 1220	3729 7552	1 contact type NO 3999 0701 1 contact type NC 3999 0702																			2 P 3898 2080 3 P 3898 3080 4 P 3898 4080
	3 P	3850 3060																									
	4 P	3850 6060																									
800 A L 8	2 P	3850 2080							Black 3859 6011	1, 3R, 12 Defeatable 143F 3111	S3 type	320 mm 12.6 inches 1400 1232	3729 7552	1 contact type NO 3999 0701 1 contact type NC 3999 0702													2 P 3898 2080 3 P 3898 3080 4 P 3898 4080
	3 P	3850 3080																									
	4 P	3850 6080																									

Common accessories - more available on next pages.

(1) No door interlocking.

(2) cage terminal connection

(3) terminal connection

Accessories

Electronic fuse operation indication (FMD)

Use

For fuse cartridge BS88, DIN and UL.

Principle

The FMD detects fuse operation using a bistable relay and a signaling LED.

It can be mounted on a DIN rail, a back plate, next to the FUSERBLOC, or on the door.

References

For FUSERBLOC 100 to 800 A			
Nb of leds	Type	Operating voltage Ph/Ph	Reference
3	FMD30	120 - 260 VAC	3899 3120
3	FMD30	380 - 690 VAC	3899 3380
Accessories			Reference
Kit for connection accessories		Standard	3819 9120
Kit for connection accessories		Door mounted	3829 9120

Relay characteristics

Type	Relay operating current I _c (A)	
	AC-15	DC-13
FMD30	2.5 A	0.2



FMD30

3-leds version

NFPA79 accessories

Flange handle for flange operation

Use

Meets both UL 508A and NFPA 79 requirements.
The handle will operate the switch by cable or rod.

Rating (A)	Type	Nema type	Reference
30 ... 200	Standard handle	1, 3, 3R, 4, 12	3729 9002 ⁽¹⁾
30 ... 200	Chrome plated handle	1, 3, 3R, 4, 4X, 12	3729 9003 ⁽¹⁾

For 400 A rating, please consult us.
(1) Defeatable handle.



smco_246_a_1_us_cat

Cable operator

Use

Link between the flange handle and the switch, please order the flange handle, the mechanism and a cable length of your choice.

Rating (A)	Description	Reference
30 ... 200	Cable flange mechanism	3729 9903

Cable length (inches)	Cable length (mm)	Reference
36	900	3729 9992
60	1500	3729 9993
120	3000	3729 9994

For 400 A rating, please consult us.



smco_247_a_1_cat

ul_042_b_1

Rod operator

Use

Link between the flange handle and the switch. The rod flange is an economical solution, please order the flange handle and a rod kit.

Rating 30 ... 200 A

For enclosure depth (inches)	For enclosure depth (mm)	Reference
8 ... 24	203 ... 613	3729 9904



ul_043_a

NFPA 79 "Through the door" kit

Use

Meets both UL 508A and NFPA 79 requirements.
Allows retrofit of your installations for ratings from 30 to 800 A.
Please order an S-type external handle separately.

Number of auxiliary contact installed on the switch will be limited to 1 layer (instead of 2).
If more needed please use the S type auxiliary contacts.
Delivered with a 12.6 in / 320 mm shaft.
For longer shafts, please consult us.

Rating (A)	Frame size	Reference
CD 30	1/2	3729 4532 ⁽¹⁾
30 ... 200	3 ... 6	3729 7540
400	7	3729 7544
600 ... 800	8	3729 7552

(1) Please use with S1 handle.



ul_121_b

FUSERBLOC UL

Fusible Disconnect Switches UL and CSA
from 30 to 800 A

Accessories

Direct handle

Rating (A)	Color	Fuses	Fig.	Reference
CD 30	Black	CC	1	3729 4012
CD 30	Black	J	1	3729 4014
30 ... 400	Black	J	2	3629 7910
600 ... 800	Black	J / L	2	3859 6011

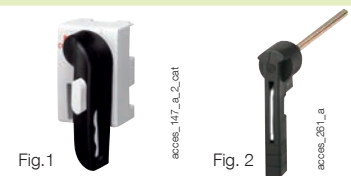

External handle

Use

The locking function of the front external handle prevents the user from opening the door of the enclosure when the switch is in the "ON" position and when the switch is padlocked in the "OFF" position (S1, S2, S3 and S4 type handles only).

Opening the door when the switch is in the "ON" position is possible by defeating the interlocking function using a tool (authorized persons only). The interlocking function is restored when the door is re-closed.



S0-type handle access_263_a_2_cat



S- type handle access_149_a_2_cat



S2-type handle access_164_a_2_cat



S3-type handle access_151_a_1_cat



Heavy-duty handle access_236.psd

Front operation

Rating (A)	Frame size	Handle type	Nema type	Test	Handle color	Reference
CD 30	1/2	S0 ⁽¹⁾	1, 3R, 12	I - 0	Black	1493 0111
CD 30	1/2	S0 ⁽¹⁾	1, 3R, 12	I - 0	Red/Yellow	1494 0111
CD 30	1/2	S0 ⁽¹⁾	4, 4X	I - 0	Black	149D 0111
CD 30	1/2	S0	4, 4X	I - 0	Red/Yellow	149E 0111
CD 30 ... 60	1/2/4	S1	1, 3R, 12	I - 0	Black	141F 2111
CD 30 ... 60	1/2/4	S1	1, 3R, 12	I - 0	Red/Yellow	141G 2111
CD 30 ... 60	1/2/4	S1	4, 4X	I - 0	Black	141D 2111
CD 30 ... 60	1/2/4	S1	4, 4X	I - 0	Red/Yellow	141E 2111
CD 30 ... 60	1/2/4	S1	4, 4X	I - 0 - Test	Black	141D 2115
CD 30 ... 60	1/2/4	S1	4, 4X	I - 0 - Test	Red/Yellow	141E 2115
60 ... 200	5 ... 7	S2	4, 4X	I - 0 - Test	Black	142D 2115
60 ... 200	5 ... 7	S2	4, 4X	I - 0 - Test	Red/Yellow	142E 2115
60 ... 400	5 ... 7	S2	1, 3R, 12	I - 0	Black	142F 2111
60 ... 400	5 ... 7	S2	1, 3R, 12	I - 0	Red/Yellow	142G 2111
60 ... 400	5 ... 7	S2	4, 4X	I - 0	Black	142D 2111
60 ... 400	5 ... 7	S2	4, 4X	I - 0	Red/Yellow	142E 2111
600 ... 800	8	S3	1, 3R, 12	I - 0	Black	143F 3111
600 ... 800	8	S3	1, 3R, 12	I - 0	Red/Yellow	143G 3111
600 ... 800	8	S3	4, 4X	I - 0	Black	143D 3111
600 ... 800	8	S3	4, 4X	I - 0	Red/Yellow	143E 3111

(1) S0: No interlock in the OFF position.

Front handle heavy duty I - 0 with metallic lever

Rating (A)	Frame size	Handle type	Nema type	Test	Handle color	Reference
CD 30 ... 60	1/2/4	S1	4, 4X	I - 0	Black	141D 2911
CD 30 ... 60	1/2/4	S1	4, 4X	I - 0	Red/Yellow	141E 2911
60 ... 400	5 ... 7	S2	4, 4X	I - 0	Black	142D 2911
60 ... 400	5 ... 7	S2	4, 4X	I - 0	Red/Yellow	142E 2911
600 ... 800	8	S3	4, 4X	I - 0	Black	143D 3911
600 ... 800	8	S3	4, 4X	I - 0	Red/Yellow	143E 3911

Right side operation

Rating (A)	Frame size	Handle type	Nema type	Test	Handle color	Reference
30 ... 60	4	S1	4, 4X	I - 0	Black	141H 6111
30 ... 60	4	S1	4, 4X	I - 0	Red/Yellow	141I 6111
100 ... 400	5 ... 7	S2	4, 4X	I - 0	Black	142H 6111
100 ... 400	5 ... 7	S2	4, 4X	I - 0	Red/Yellow	142I 6111
600 ... 800	8	S3	4, 4X	I - 0	Black	consult us
600 ... 800	8	S3	4, 4X	I - 0	Red/Yellow	consult us

S-type handle raiser

Use

Enables S-type handles to be fitted in place of older-style SOCOMEC handles. An adapter can also be used as a spacer to increase the distance between the panel door and the handle lever.

Dimensions

Increases distance to door by 0.47 in / 12 mm.

Handle color	Pack qty	External degree of protection (IP)	Reference
Black	10	IP65	1493 0000



accses_187_a_1_cat

Alternative color S-type handle cover

Use

For single lever handle S-type S1, S2, S3 and double lever handle, type S4. Other colors: please consult us.

Handle color	Pack qty	Handle type	Reference
Light grey	50	S2, S3	1401 0001
Dark grey	50	S2, S3	1401 0011
Light grey	50	S4	1401 0031
Dark grey	50	S4	1401 0041



accses_198_a_1_cat

Shaft for external handle

Use

Standard lengths:
- 7.9 in / 200 mm,
- 12.6 in / 320 mm,
- 15.7 in / 400 mm.

Other lengths: please consult us.

Rating (A)	Dimensions X		Length		Reference
	(in)	(mm)	(in)	(mm)	
CD 30	4.02 ... 9.65	102 ... 245	7.9	200	1405 0620
CD 30	4.02 ... 14.37	102 ... 365	12.6	320	1405 0632
CD 30	4.02 ... 17.52	102 ... 445	15.7	400	1405 0640
CD 30	4.02 ... 9.65	102 ... 245	7.9	200	1401 0520
CD 30	4.02 ... 14.37	102 ... 365	12.6	320	1401 0532
CD 30	4.02 ... 17.52	102 ... 445	15.7	400	1401 0540
30 ... 100	5.3 ... 9.06	135 ... 230	7.9	200	1400 1020
30 ... 100	5.3 ... 13.78	135 ... 350	12.6	320	1400 1032
30 ... 100	5.3 ... 16.93	135 ... 430	15.7	400	1400 1040
30 ... 100	5.3 ... 20.87	135 ... 530	19.7	500	1400 1050
200	5.7 ... 9.06	145 ... 230	7.9	200	1400 1020
200	5.7 ... 13.78	145 ... 350	12.6	320	1400 1032
200	5.7 ... 16.93	145 ... 430	15.7	400	1400 1040
200	5.7 ... 20.87	145 ... 530	19.7	500	1400 1050
400	7.87 ... 10.24	200 ... 260	7.9	200	1400 1020
400	7.87 ... 14.96	200 ... 380	12.6	320	1400 1032
400	7.87 ... 18.1	200 ... 460	15.7	400	1400 1040
400	7.87 ... 22	200 ... 560	19.7	500	1400 1050
600 ... 800	10.63 ... 11.97	270 ... 304	7.9	200	1400 1220
600 ... 800	10.63 ... 16.69	270 ... 424	12.6	320	1400 1232
600 ... 800	10.63 ... 19.84	270 ... 504	15.7	400	1400 1240
600 ... 800	10.63 ... 23.78	270 ... 604	19.7	500	1400 1250

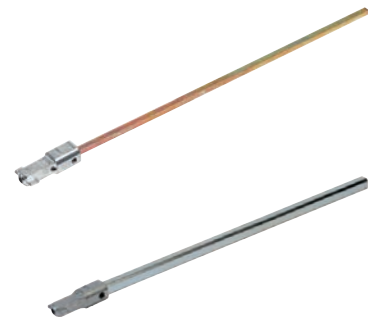

accses_145_b_1_cat

accses_389_a_1_cat

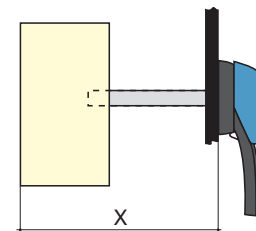

accses_202_a_1_cat

FUSERBLOC UL

Fusible Disconnect Switches UL and CSA
from 30 to 800 A

Accessories (continued)

External front operation shaft support accessory

Use

This support maintains shaft position for extension shafts greater than 12.6 in / 320 mm in length.

Rating (A)	Frame size	Reference
50 ... 400	11 ... 16	3899 0400



Shaft guide for external handle

Use

This accessory enables handle to engage shaft with a misalignment of up to 0.59 in / 15 mm. Required for a shaft length over 400 mm for S1 to S3 handles and for a shaft from 12.6 in / 320 mm for S0 handle.

Description	Reference
Shaft guide for S1 to S3 handles	1429 0000
Shaft guide for S0 handle	1419 0000



U-type auxiliary contacts

Use

U-type AC can be configured to be operated on both standard and TEST position switches from CD 30 to 800 A. Each slot can accommodate up to 2 interlocked ACs.

- For CD 30A/CC, a maximum of 4 ACs (8 with an additional holder);
- For CD 30A/J, maximum 2 ACs (6 with an additional holder),
- For 30 to 200A/J, maximum 4 ACs.
- For 400 to 800A/L, maximum 8 ACs.

Electrical characteristics

A600.

When FUSERBLOC is front operated, ACs are prebreak and signaling position I and 0. When FUSERBLOC is side operated, ACs are signaling positions I and 0.

NO auxiliary contacts		
Rating (A)	Number of contacts	Reference
CD 30 ... 800	1	3999 0701

NC auxiliary contacts		
Rating (A)	Number of contacts	Reference
CD 30 ... 800	1	3999 0702

Contact holder for additional auxiliary contacts			
Rating (A)	Fuses	Reference	
CD 30	CC	3999 0710	
CD 30	J	3999 0710	

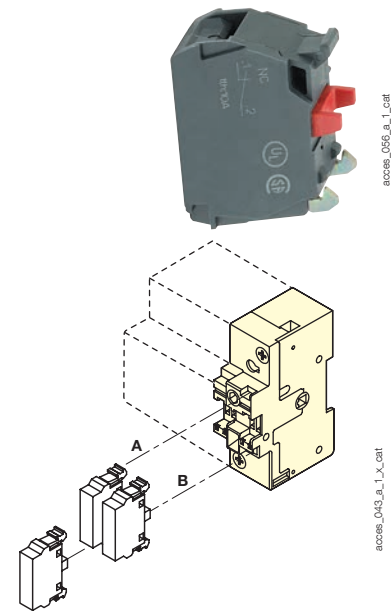

CD 30 : U-type auxiliary contacts cannot be mounted on switches with direct operation handle

S-type auxiliary contacts

Use

Side-operated auxiliary contacts for FUSERBLOC 30 to 400 A, position OFF and ON signaled by 1 to 4 NO + NC auxiliary contacts.

Electrical characteristics

A600/D600.

S-type auxiliary contacts are signaling position I and 0.

NO+NC auxiliary contacts		
Rating (A)	Number of contacts	Reference
30 ... 800	1	3999 U041
30 ... 800	2	3999 U042

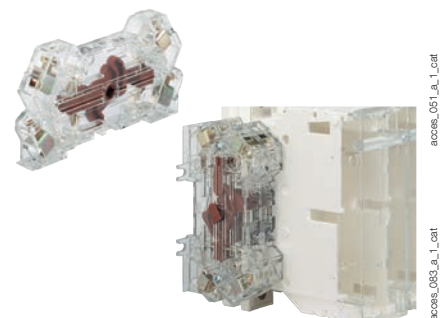

Terminal shrouds

Use

Top or bottom protection against direct contact with terminals or connection parts.
2 sets required to fully shroud both line and load terminals.

Front and side operation		
Rating (A)	No. of poles	Reference ⁽¹⁾
30 ... 100	2/3/4 P	as standard
200	2 P	3898 2020
200	3 P	3898 3020
200	4 P	3898 4020
400	2 P	3898 2040 ⁽²⁾
400	3 P	3898 3040 ⁽²⁾
400	4 P	3898 6040 ⁽²⁾
600 ... 800	2 P	3898 2080 ⁽³⁾
600 ... 800	3 P	3898 3080 ⁽³⁾
600 ... 800	4 P	3898 4080 ⁽³⁾

(1) Top or bottom. (2) Not compatible with 2 wire lugs (3954x041). (3) Line side delivered as standard.



fuser_314_a_1_cat

Terminals lugs

Use

Connection of cables to the terminals.

Rating (A)	Wires range	No wires per lug	Lugs per kit	Wires	Reference
CD 30	#14 - #10	1		Cu	as standard
30	#14 - #10	1		Cu	as standard
30 ... 60	#10 - #6	1		Cu	as standard
60 ... 100	#12 - #1	1		Cu	as standard
100	#14 - #2/0	1	3	Cu / Al	3954 3011
200	#6 - 300MCM	1	2	Cu / Al	3954 2020
200	#6 - 300MCM	1	3	Cu / Al	3954 3020
200	#6 - 300MCM	1	4	Cu / Al	3954 4020
400	#2 - 600MCM	1	2	Cu / Al	3954 2040
400	#2 - 600MCM	1	3	Cu / Al	3954 3040
400	#2 - 600MCM	1	4	Cu / Al	3954 4040
400	2 x (#6 - 350 MCM)	2	2	Cu / Al	3954 2041
400	2 x (#6 - 350 MCM)	2	3	Cu / Al	3954 3041
400	2 x (#6 - 350 MCM)	2	4	Cu / Al	3954 4041
600 ... 800	2 x (#2 - 600MCM)	1	2	Cu / Al	3954 2060
600 ... 800	2 x (#2 - 600MCM)	2	3	Cu / Al	3954 3060
600 ... 800	2 x (#2 - 600MCM)	2	4	Cu / Al	3954 4060



u_0032_a

Solid links

Rating (A)	Fuses	No of links per kit	Reference
100	J	3	3799 9010
200	J	3	3799 9020
400	J	3	3799 9040
600 ... 800	J / L	3	3799 9080



fuser-ul_019_a_1_cat

Class T fuse adapter

Use

The adapter makes it possible to fit class T fuses in the FUSERBLOC fuse switches.

Rating (A)	Size Class T fuse		No. of poles	Reference
	(in)	(mm)		
100	2.34	59.5	3 P	3729 8010
200	2.48	63	3 P	3729 8020
400	2.71	69	3 P	3729 8040
600	2.95	75	3 P	3729 8060
800	3.17	80.5	3 P	3729 8080

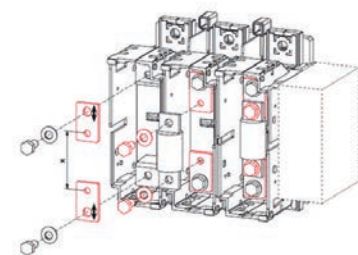

fuser-ul_014_b_1_cat

FUSERBLOC UL

Fusible Disconnect Switches UL and CSA

from 30 to 800 A

Characteristics according to UL 98/CSA 22.2 #4

CD 30 to 800 A

Characteristics UL and CSA	CD 30 A ⁽³⁾	CD 30 A ⁽⁴⁾	30 A	60 A	60 A	100 A	100 A	200 A	400 A	600 A	800 A
Frame size	1	2	4	4	5	5	5	6	7	8	8
Short circuit rating at 600 VAC (kA)	100	100	200	100	200	200	200	200	200	200	200
Type of fuse	CC	J	J	J	J	J	J	J	J	J	L
Max. fuse rating (A)	30	30	30	60	60	100	100	200	400	600	800
Max. motor hp / FLA 1 ph motor max.											
120 VAC	2 / 24	2 / 24	2 / 24	5 / 56	5 / 56	7.5 / 80	7.5 / 80	15 / 135	-	-	-
240 VAC	5 / 28	5 / 28	5 / 28	10 / 50	10 / 50	20 / 88	20 / 88	40 / 176	50 / 216	-	-
Max. motor hp / FLA 3 ph motor max.											
220-240 VAC	7.5 / 22	7.5 / 22	7.5 / 22	15 / 42	15 / 42	30 / 80	30 / 80	60 / 154	125 / 312	200 / 480	200 / 480
440-480 VAC	15 / 21	15 / 21	15 / 21	30 / 40	30 / 40	60 / 77	60 / 77	125 / 156	250 / 302	500 / 590	500 / 590
600 VAC	20 / 22	20 / 22	20 / 22	50 / 52	50 / 52	75 / 77	75 / 77	150 / 144	350 / 336	500 / 472	500 / 472
125 VDC ⁽¹⁾	3 / 25	3 / 25	3 / 25	3 / 25	3 / 25	7.5 / 58	7.5 / 58	15 / 112	20 / 148	-	-
250 VDC ⁽²⁾	5 / 20	5 / 20	5 / 20	10 / 38	10 / 38	20 / 38	20 / 38	40 / 140	50 / 173	-	-
Mechanical endurance											
Endurance (number of operating cycles)	10 000	10 000	10 000	10 000	10 000	10 000	10 000	8 000	6 000	5 000	5 000
Operating torque (lbs.in / Nm)	31 / 3.5	31 / 3.5	71 / 8	71 / 8	71 / 8	71 / 8	71 / 8	90 / 10.2	150 / 17	586 / 66.2	586 / 66.2
Connection											
Connection type	Cage	Cage	Cage	Cage	Cage	Cage	Terminal	Terminal	Terminal	Terminal	Terminal
Min. connection cross-section/ (mm ²) ⁽³⁾	#14	#14	#14 ⁽⁴⁾ (5)	#14 ⁽⁴⁾ (5)	#10	#10	#14	#6	#2 or 2 x #6	2 x #2	2 x #2
Max. connection cross-section/ (mm ²) ⁽⁴⁾	#10	#10	#10 ⁽⁴⁾ (6)	#10 ⁽⁴⁾ (6)	#2/0	#2/0	#2/0	300MCM	600MCM or 2 x 350MCM	2 x 600MCM	2 x 600MCM

(1) 2 pole in series.

(2) 3 pole in series.

(3) UL 489/CSA22.2 #5.

(4) Double wire solid Cu min and max 2 x #10

(5) Double wire stranded Cu min 2 x #12

(6) Double wire stranded Cu max 2 x #10

Dimensions (in/mm)

CD 30 A / CC - Frame size 1

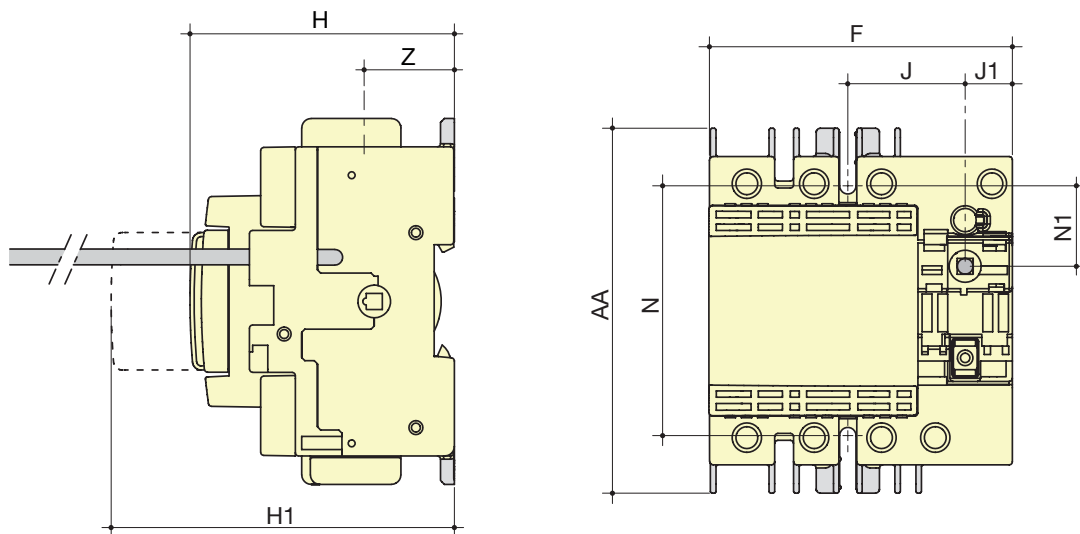

Rating (A) / Fuse	Unit	Switch body					Switch mounting		Connection	
		F	H	H1	J	J1	N	N1	AA	Z
CD 30 A / CC	in	3.78	3.28	5.19	1.47	0.59	3.13	1	4.56	1.12
	mm	96	83.5	132	37.5	15	79.5	25.5	116	28.5

fuser_655_a_1_x_021

30 to 60 A / J - Frame size 2

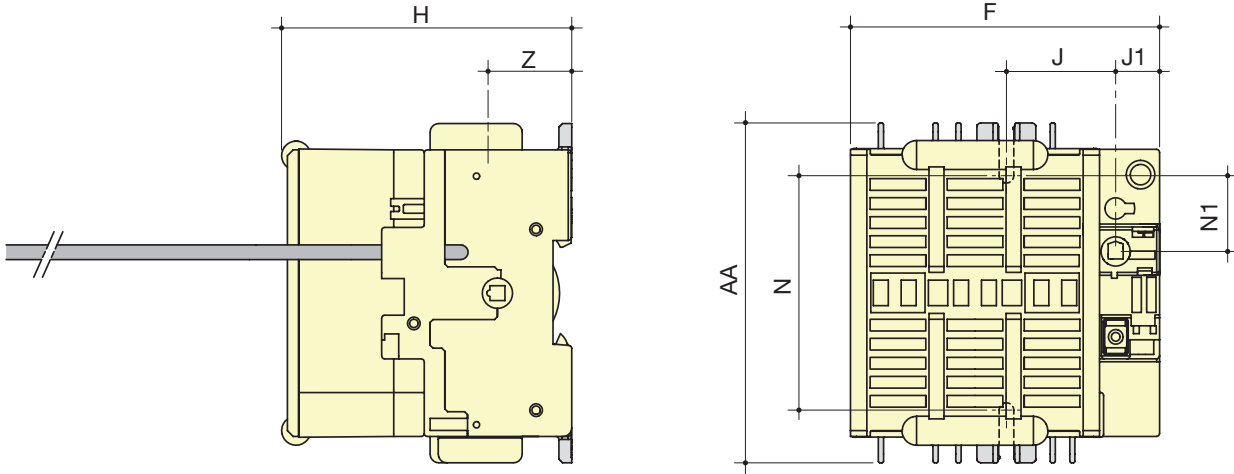

fuser_656_a1_LX_021

Rating (A) / Fuse	Unit	Switch body				Switch mounting		Connection	
		F	H	J	J1	N	N1	AA	Z
CD 30 A / J	in	4.13	3.89	1.47	0.59	3.30	1	4.56	1.12
	mm	105	99	37.5	15	84	25.5	116	28.5

30 to 60 A / J - Frame size 4

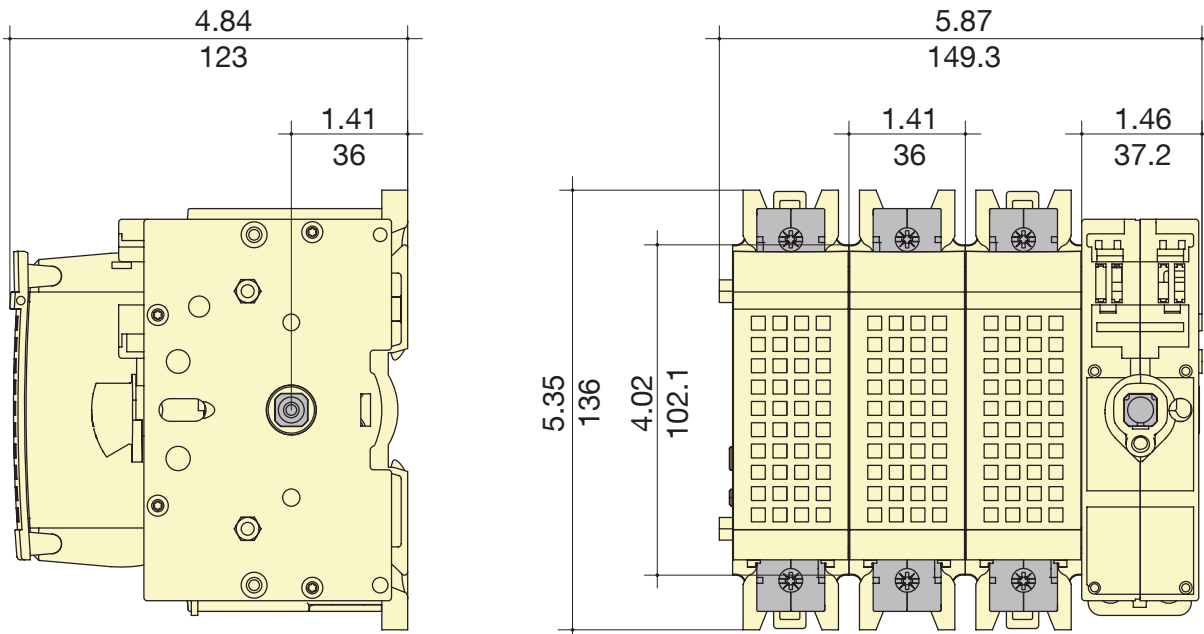

Note for width:
For 2 pole device decrease overall width by 1.41 in / 36 mm.
For 4 pole device increase overall width by 1.41 in / 36 mm.

FUSERBLOC UL

Fusible Disconnect Switches UL and CSA
from 30 to 800 A

Dimensions (in/mm) (continued)

60 to 100 A / J - Frame size 5 - cage connection

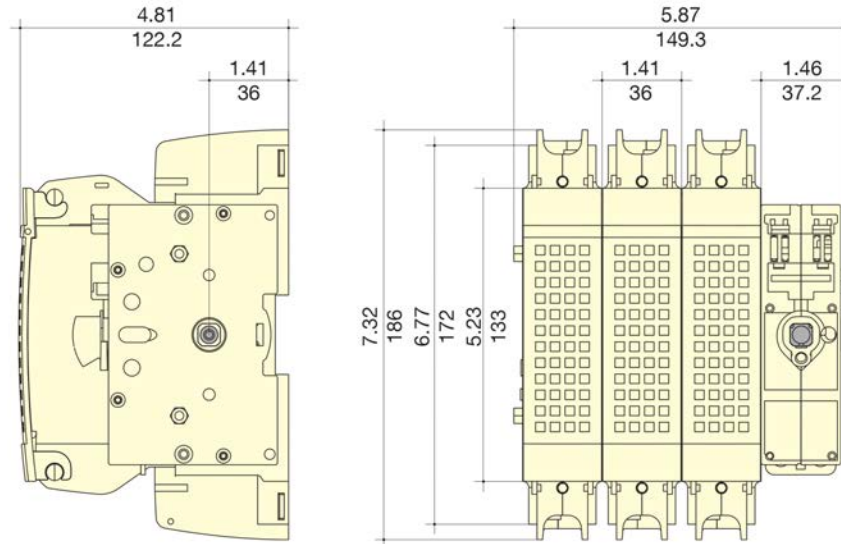

Note for width:

For 2 pole device decrease overall width by 1.41 in / 36 mm.

For 4 pole device increase overall width by 1.41 in / 36 mm.

100 A / J - Frame size 5 - terminal connection

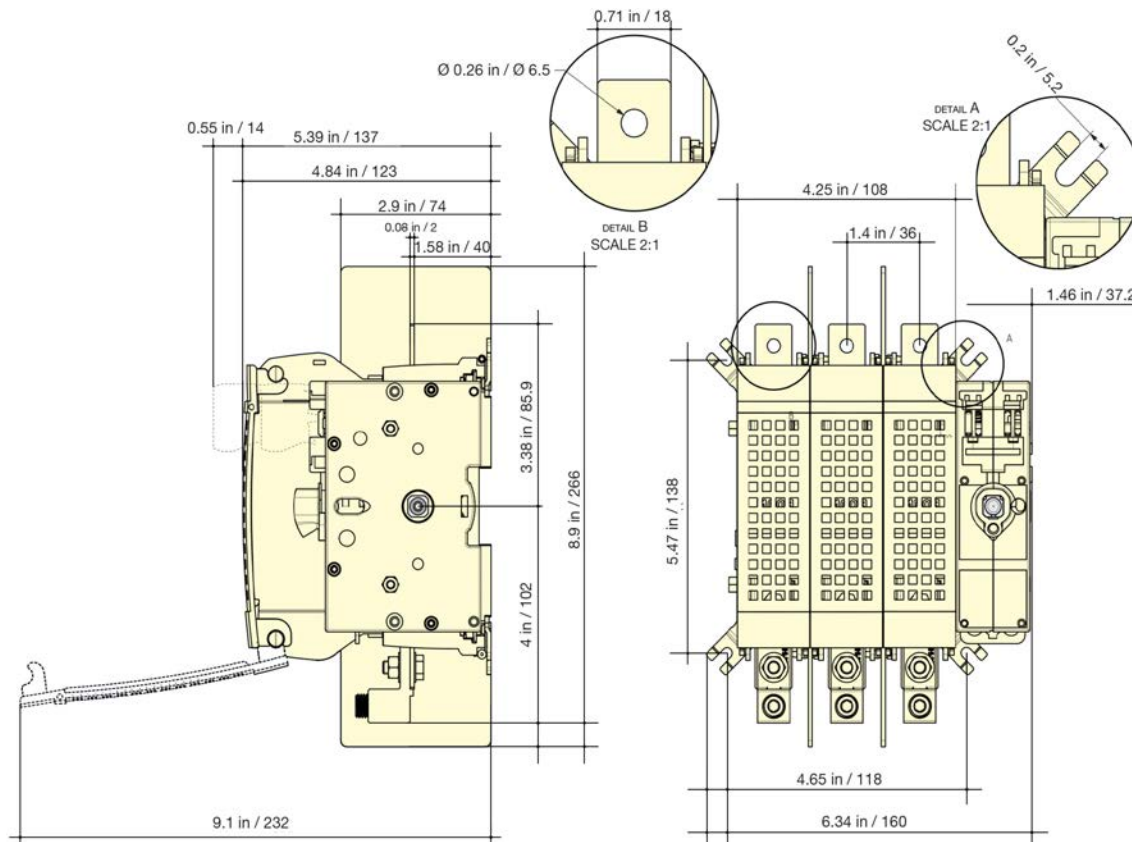

200 A / J - Frame size 6

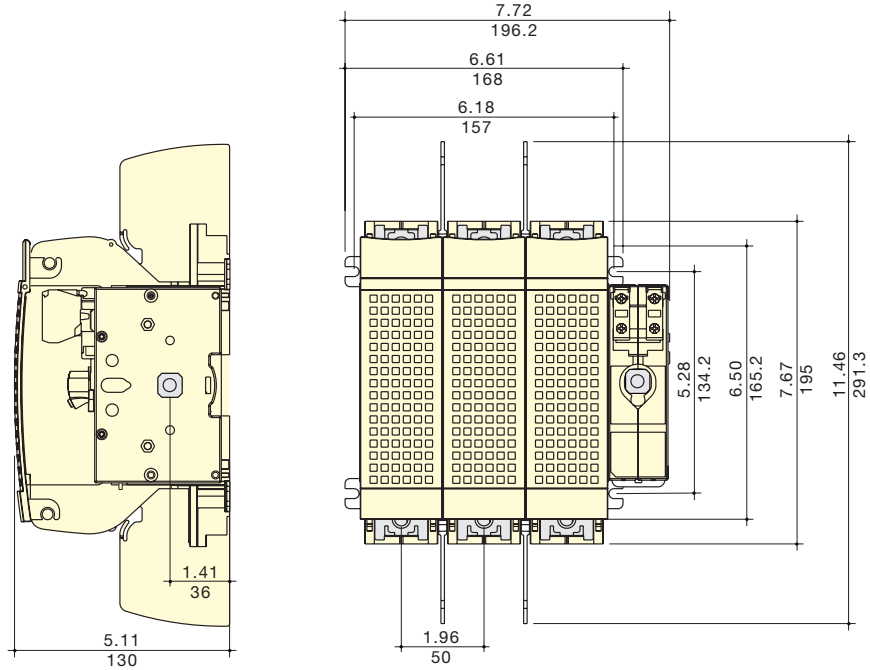

fuser-ul_003_a_1_x_cat

Note for width:

For 2 pole device decrease overall width by 1.96 in / 50 mm.

For 4 pole device increase overall width by 1.96 in / 50 mm.

400 A / J - Frame size 7

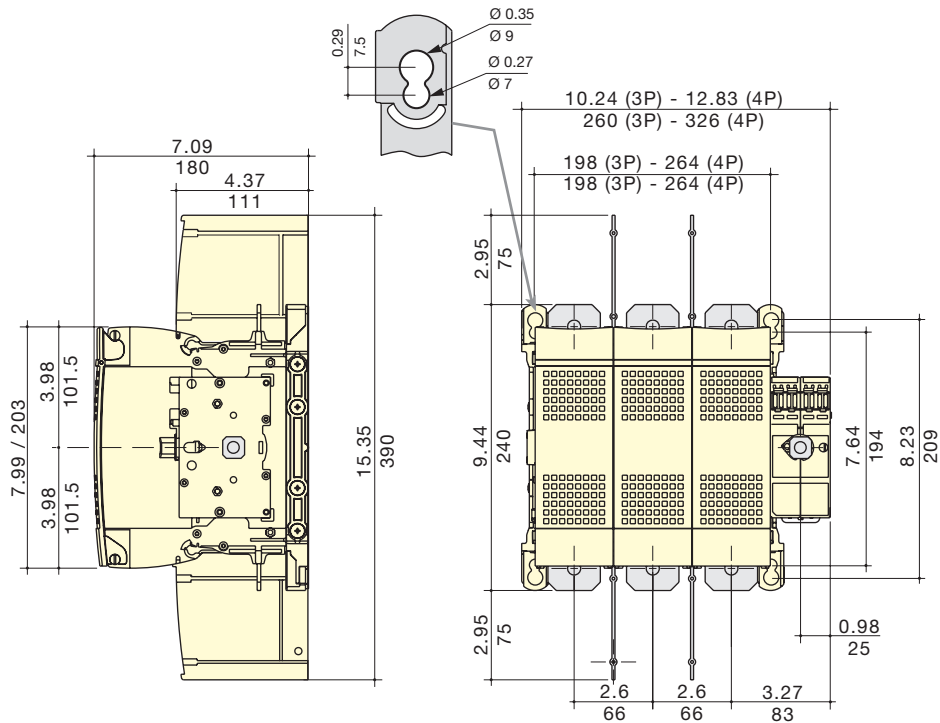

fuser-ul_004_d_1_x_cat

Note for width:

For 2 pole device decrease overall 3 pole width by 2.59 in / 66 mm.

FUSERBLOC UL

Fusible Disconnect Switches UL and CSA
from 30 to 800 A

600 to 800 A / J - Frame size 8

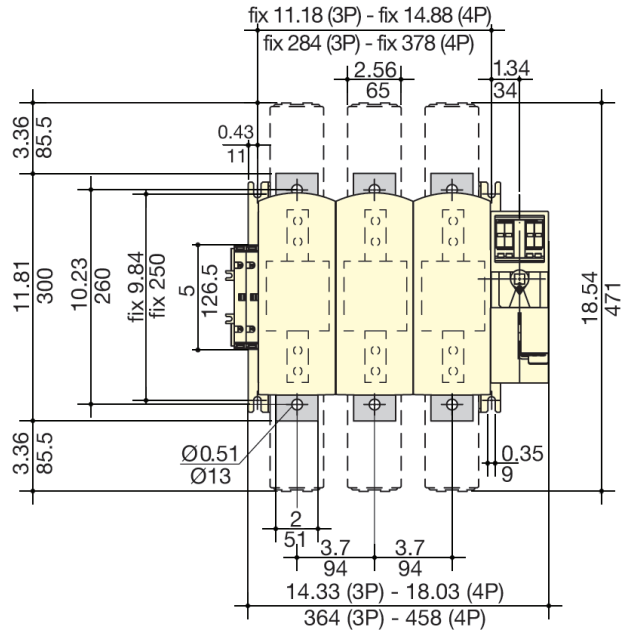
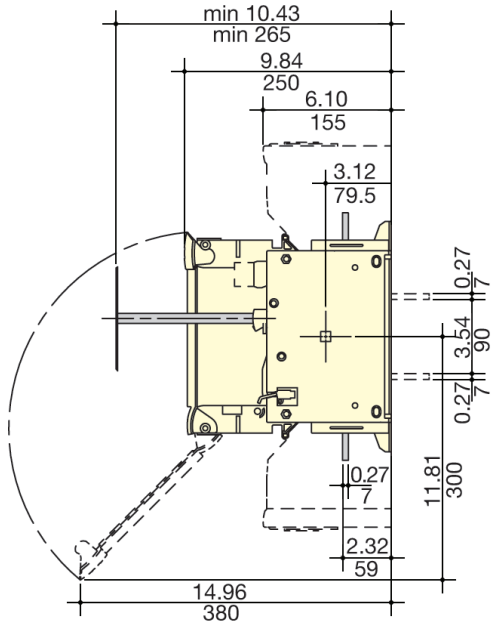

Note for width:
For 2 pole device decrease overall 3 pole width by 3.7 in / 94 mm.

fuser_031_b_1_gp_cat

Dimensions (in/mm) (continued)

30 to 400 A

Front direct handle

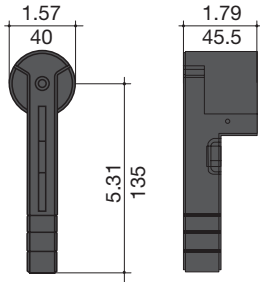

sipec-ul_027_a_1_x_cat

600 to 800 A

Front direct handle

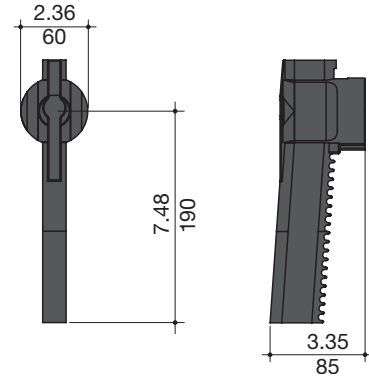

sipec_267_b_1_x_cat

External handle dimensions (in/mm)

CD 30 A - Frame size 1 / 2

Handle type	Front operation Direction of operation	Side operation Direction of operation	Door drilling
<p>S0 type</p>			<p>With 4 fixing screws</p> <p>With fixing nut</p>

fuser-ul_015_a_1_gb_cat

FUSERBLOC UL

Fusible Disconnect Switches UL and CSA

from 30 to 800 A

External handle dimensions (in/mm)

CD 30 to 60 A - Frame size 1 / 2 / 4

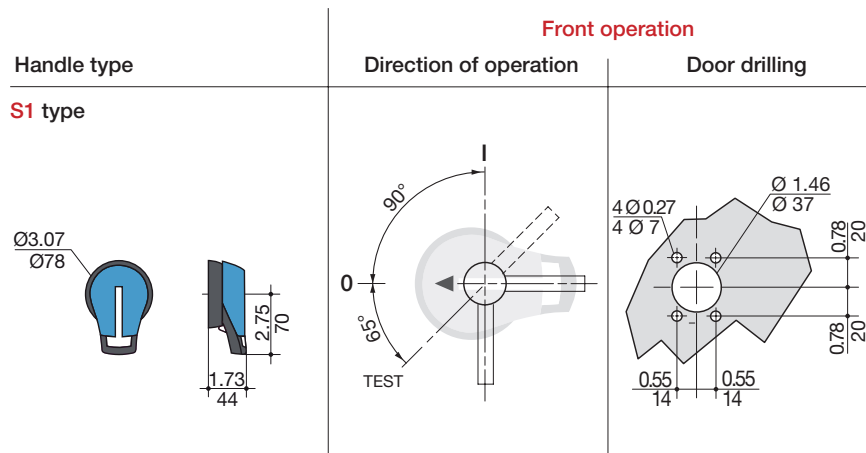

fuser-ul_015_b_1_gp_cat

60 to 400 A - Frame size 5 / 6 / 7

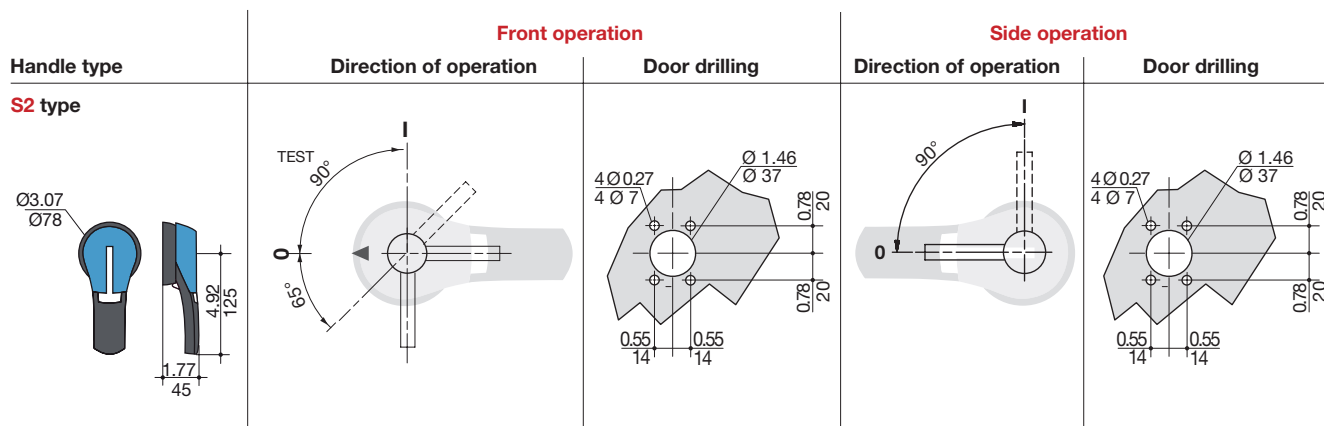

fuser-ul_016_b_1_gp_cat

600 and 800 A - Frame size 8

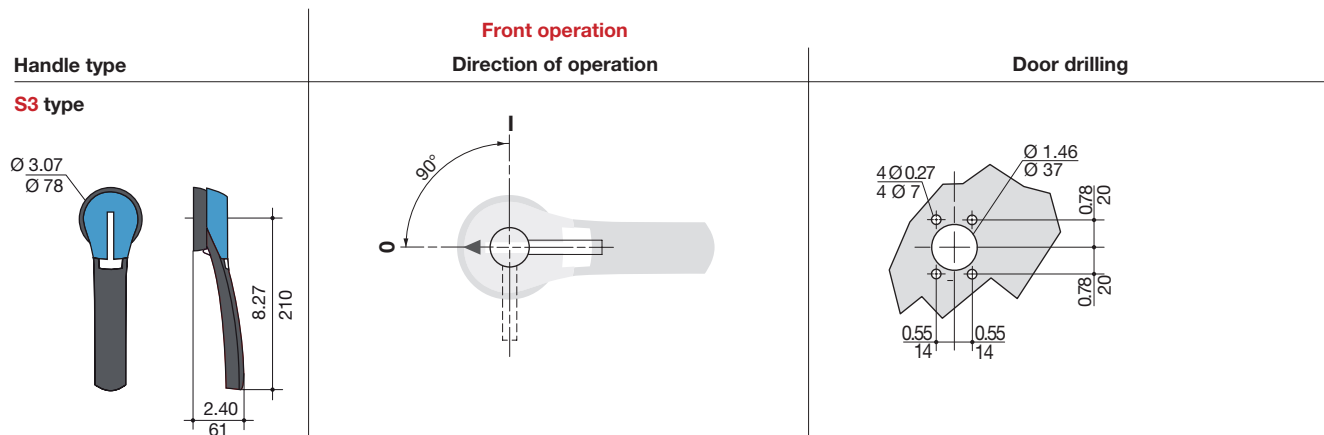

fuser-ul_017_b_1_gp_cat

Terminal lugs (in/mm)

100 A

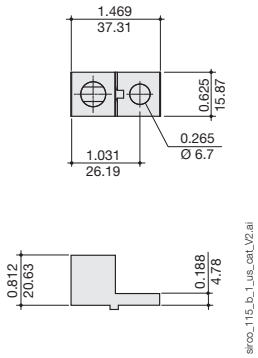

200 A

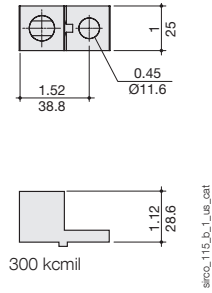

400 A

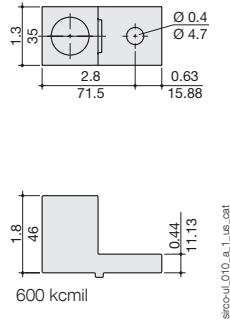

400 A

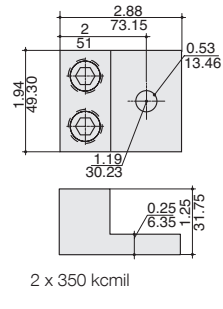

600 to 800 A

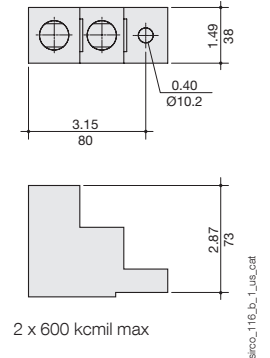

FUSERBLOC DRIVE 1PP

Single-pole pre-charge fuse combination switches for variable speed drives from 600 to 1700 A

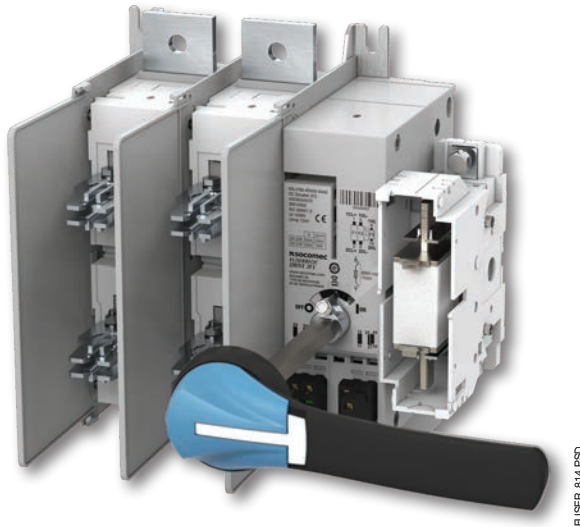

FUSERBLOC DRIVE 1PP

The Solution For

- > Energy
- > Industry

Strong points

- > Simple and compact
- > Automatic pre-charging
- > Optimized maintenance
- > Optimized safety

Conformity to Standards

- > IEC 60947-3
- > UL 98

Function

FUSERBLOC DRIVE units with manual front operation are multipole DC fuse load break switches. They offer short circuit protection for all low-voltage electrical circuits of capacitive loads (capacitor) by limiting the high inrush current during circuit power-up and are designed to allow maintenance work on DC/AC variable speed drives or PV inverters without shutting down the entire installation. The range is available in direct and external operation, with 2 power poles + 1 pre-charge pole, up to 1700 A.

Advantages

Simple and compact

The FUSERBLOC Drive unit is the most compact and simple solution in the market for variable speed drives under a common DC bus. This product combines 3 functions, namely disconnection, protection and precharging in one and the same device.

Automatic pre-charging

After servicing operations, pre-charging of inverter capacitors is managed automatically via a coil. Further, the opening of the precharging poles and closing of the power poles is also carried out automatically.

Optimized maintenance

This multifunction device enables maintenance work to be done on part of the power system while leaving the rest of the equipment powered on.

Optimized safety

Double phase isolation (upstream-downstream from the fuse), disconnection and padlocking keep personnel completely safe while replacing a fuse. The device is capable of maintaining the OFF, pre-charge or ON position in the event of power failure.

General characteristics

- For high-speed fuses up to 1700 A.
- Up to 1250 VAC, 1000 VDC.
- Up to 100 kA.
- Utilisation category DC 20B.
- 2 power poles + 1 pre-charge pole.

References

External / direct operation 630 to 1700 A

Rating (A)	Frame size	Main poles			Pre-charge poles			Reference	External front handle	Shaft for external front handle	Coil	Auxiliary contacts
		No. of poles	Fuse size	Fuse type	No. of poles	Fuse size	Fuse type					
630 A	2F3	2	Size 3	KN/110 or DIN 43620	1	Size 0	DIN 43620	38S1 2060	1433 3111	1402 1240	Pre-mounted (24VDC)	Pre-mounted 3NO+2NC
800 A	2F4	2	Size 3	KN/110 or DIN 43620	1	Size 0	DIN 43620	38S1 2080				
1200 A	2x2F3	4 (2//)	Size 3	KN/110 or DIN 43620	1	Size 0	DIN 43620	38S1 4100				
1700 A	2x2F4	4 (2//)	Size 3	KN/110 or DIN 43620	1	Size 0	DIN 43620	38S1 4160				

Operating diagram

Main poles and auxiliary contacts

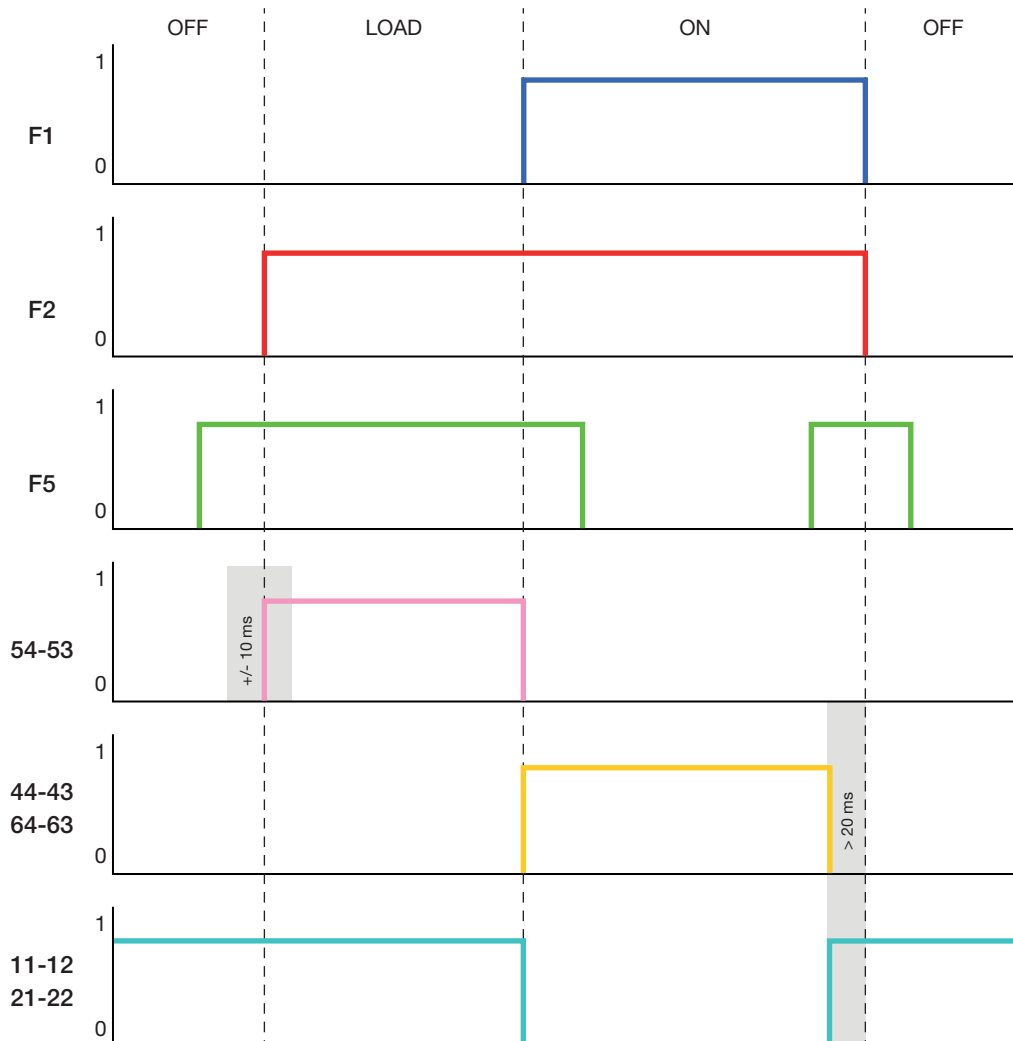

FUSERBLOC DRIVE 1PP

Single-pole pre-charge fuse combination switches for variable speed drives from 600 to 1700 A

Operating diagram

Main poles and auxiliary contacts

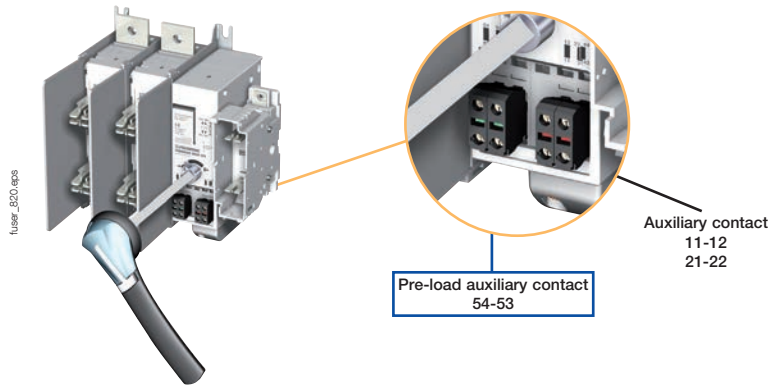

MANUAL - Step 1

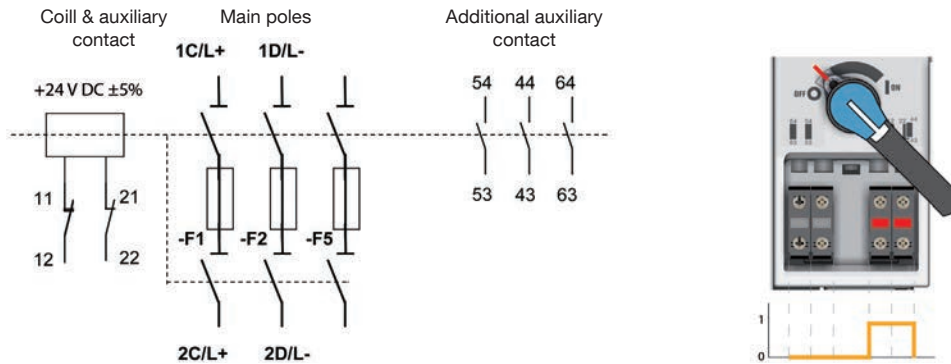

MANUAL - Step 2

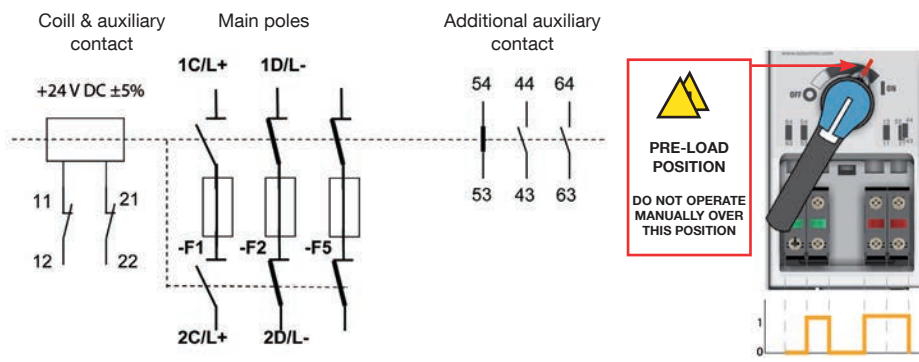

AUTO - Step 3

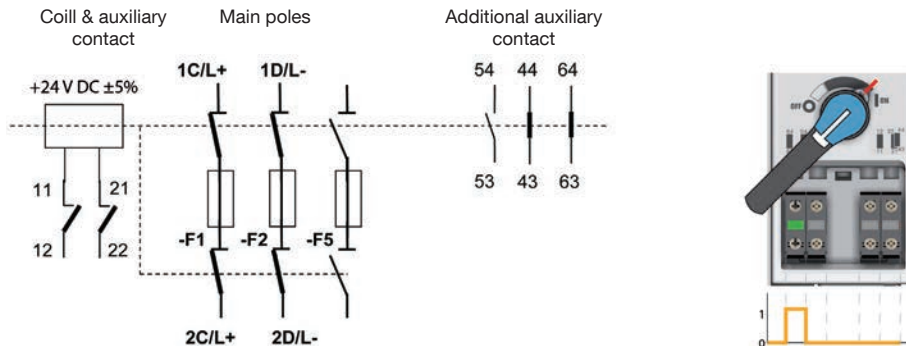

Characteristics according to IEC characteristics 60947-3

630 to 1700 A

Rating (A)	630	800	1200	1700
References	38S1 2060	38S1 2080	38S1 4100	38S1 4160
Frame size	2F3	2F4	2x2F3	2x2F4
Main poles				
No. of poles	2	2	4(2//)	4(2//)
Thermal current I _{th} at 40°C (A)	630	800	1200	1700
Fuse DIN size	Size 3	Size 3	Size 3	Size 3
Fuse type	KN/110 or DIN 43620	KN/110 or DIN 43620	KN/110 or DIN 43620	KN/110 or DIN 43620
Rated voltage U _e (V)	1035	1035	1035	1035
Rated insulation voltage U _i (V)	1250	1250	1250	1250
Rated impulse withstand voltage U _{imp} (kV)	12	12	12	12
Load duty category	DC-20B	DC-20B	DC-20B	DC-20B
Prospective short-circuit current (kA rms)(1)	35	35	35	35
Maximum switch heat dissipation per pole (W)	100	130	100	165
Mechanical characteristics				
Coil voltage ± 5% (V DC)	24	24	24	24
Operating force (Nm)	45	45	45	60
Heat dissipation per pole (W)	149	300	/	/
Endurance (number of operating cycles)	1000	1000	1000	1000
Coil maximum current under 24 VDC (with coil of 400 W) ± 10% (A)	15	15	15	15
Pre-charge poles				
No. of poles	1	1	1	1
Thermal current I _{th} at 40°C (A)	160	160	160	160
Fuse DIN size	Size 0	Size 0	Size 0	Size 0
Fuse type	DIN 43620	DIN 43620	DIN 43620	DIN 43620
Rated insulation voltage U _i (V) (operation circuit)	1000	1000	1000	1000
Rated impulse withstand voltage U _{imp} (kV) (operation circuit)	8	8	8	8
Load duty category	DC-20B	DC-20B	DC-20B	DC-20B
Prospective short-circuit current (kA rms)(1)	20	20	20	20
Maximum switch heat dissipation per pole (W)	23	23	23	23
Mechanical characteristics				
Endurance (number of operating cycles)(2)	1500	1500	1500	1500
Operating force (Nm)	45	45	45	60
Maximum connexion capacity per pole (mm ²)	95	95	95	95
Minimum connexion capacity per pole (mm ²)	50	50	50	50
Coil				
Coil	Pre-mounted (24VDC)	Pre-mounted (24VDC)	Pre-mounted (24VDC)	Pre-mounted (24VDC)
U _e (VDC)	24	24	24	24
Rated insulation voltage U _i (V)	1000V	1000V	1000V	1000V
I _e (A) for 400W coil	15	15	15	15
Maximum power	400W	400W	400W	400W
Auxiliary contacts				
Auxiliary contact type	3NO+2NC	3NO+2NC	3NO+2NC	3NO+2NC
Thermal current I _{th} at 40°C (A)	10A	10A	10A	10A
Rated Operating Current I _e	5A	5A	5A	5A
Rated voltage U _e (V)	240VAC/24VDC	240VAC/24VDC	240VAC/24VDC	240VAC/24VDC
Load duty category	AC15/DC-13	AC15/DC-13	AC15/DC-13	AC15/DC-13
Approvals & Conformity				
Approvals and certifications	IEC-CCC	IEC-CCC	IEC-CCC	IEC-CCC
Conformity to standards	GB/T14048-3 IEC60947-3	GB/T14048-3 IEC60947-3	GB/T14048-3 IEC60947-3	GB/T14048-3 IEC60947-3

FUSERBLOC DRIVE 1PP

Single-pole pre-charge fuse combination switches for variable speed drives
from 600 to 1700 A

Dimensions

DC switches 630 A

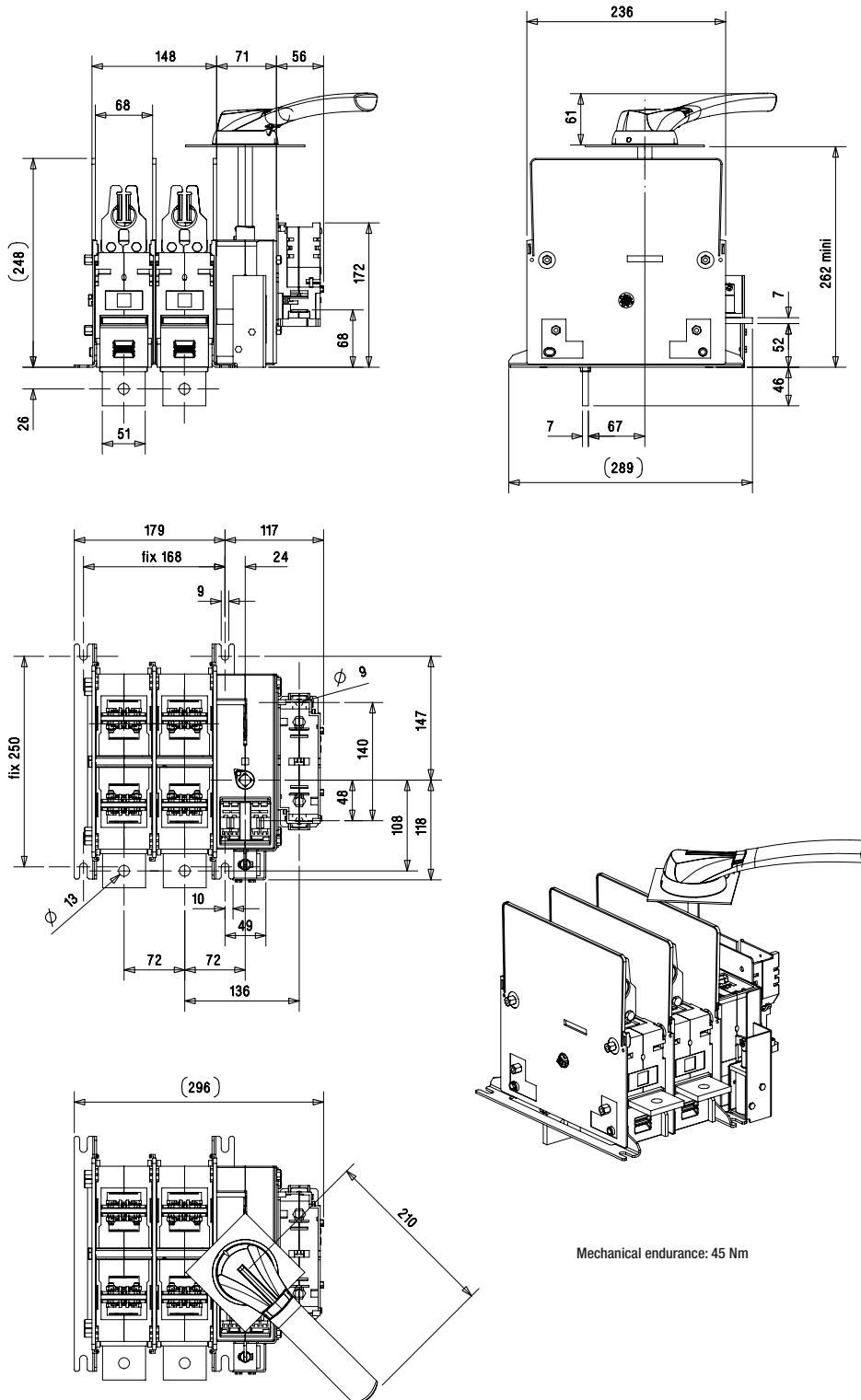

Mechanical endurance: 45 Nm

fuser_675_a_1_gb_conf.eps

FUSERBLOC DRIVE 1PP

Single-pole pre-charge fuse combination switches for variable speed drives
from 600 to 1700 A

DC switches 800 A

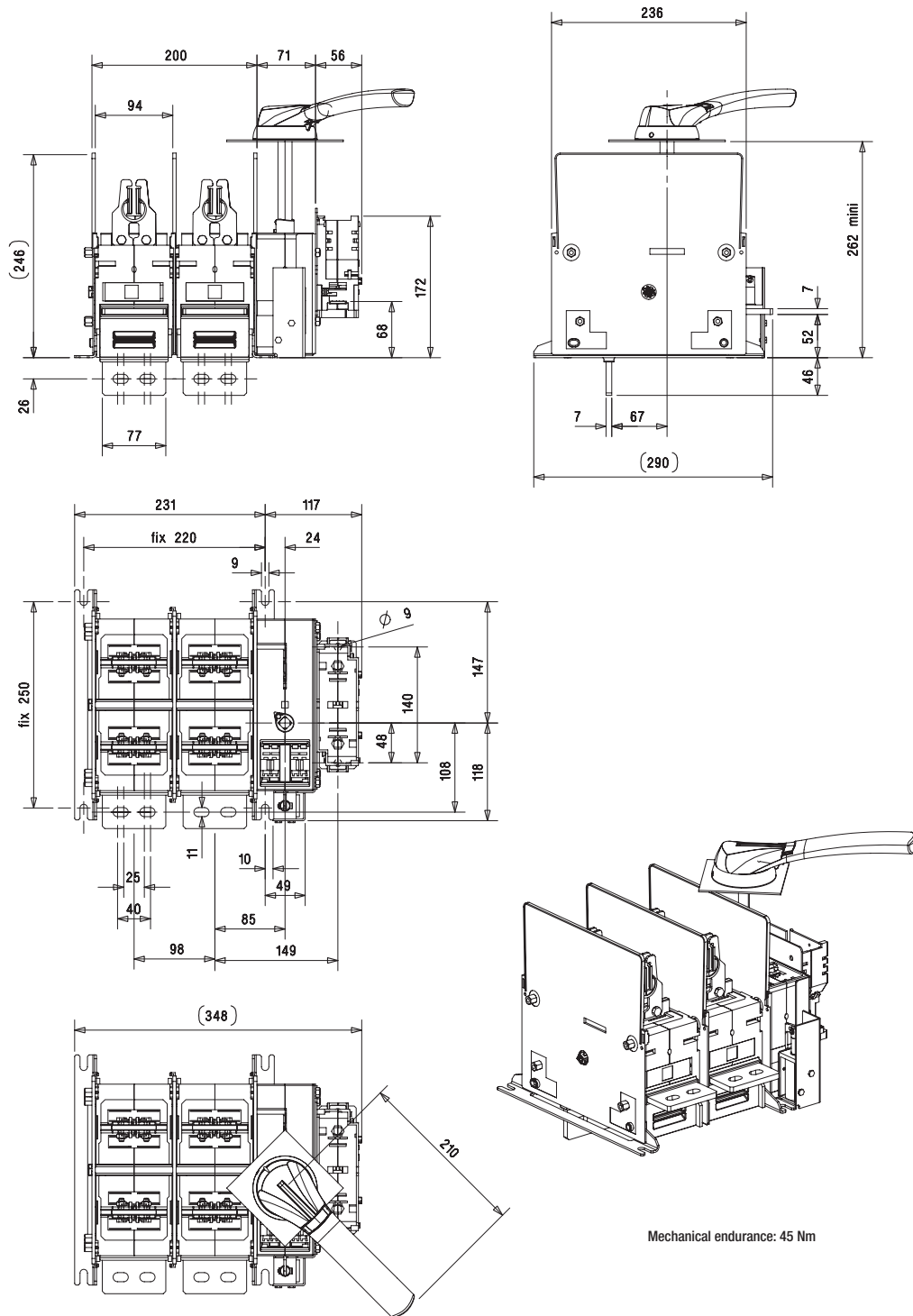

fuser_676_a_1_gp_cat.eps

FUSERBLOC DRIVE 1PP

Single-pole pre-charge fuse combination switches for variable speed drives
from 600 to 1700 A

Dimensions

DC switches 1200 A

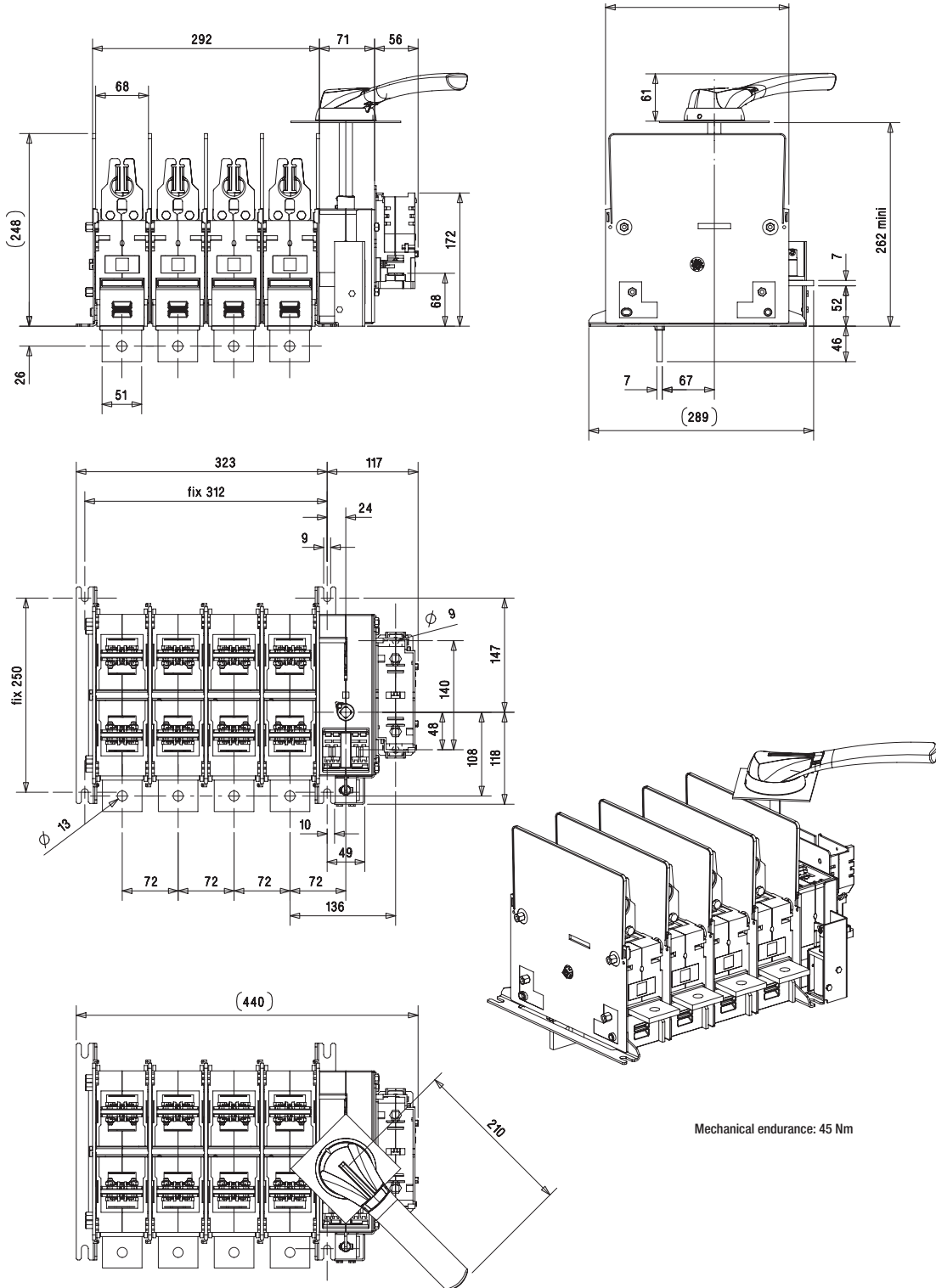

fuser_6177_a_1_gp_cad.rps

FUSERBLOC DRIVE 1PP

Single-pole pre-charge fuse combination switches for variable speed drives
from 600 to 1700 A

DC switches 1700 A

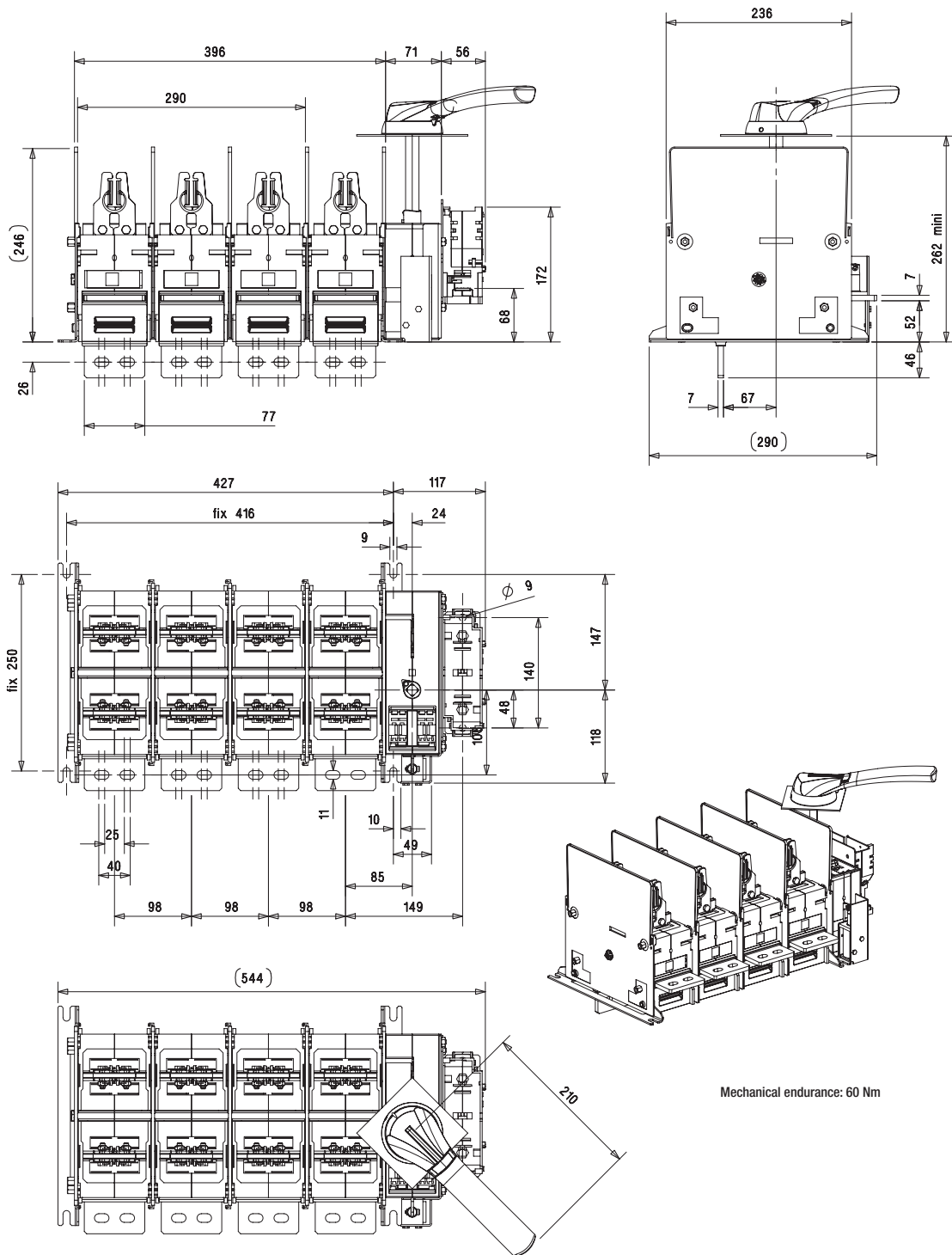

user_678_a1_igd_cat.eps

RM CC

Modular Fuse Holders

For CC fuses



Function

RM CC are modular DIN rail mounted fuse holders for UL Class CC fuses. They are available with and without LED indication in 1, 2 and 3-pole versions. RM CC fuse holders are IP20 protected from touch by fingers and provide safe non-load breaking and isolation of electrical circuits up to 600 V / 30 A.

Advantages

Improved safety

- Multipolar and simultaneous disconnection
- High dielectric strength
- Protection IP2X

High breaking capacity

Protection against overload and short-circuit events due to the high breaking capacity of fuses (200 kA rms).

Accessories

- Padlocking kits
- Coupling kits

The Solution For

- > Industrial control panels
- > Motor and control circuits
- > Transformers protection
- > Measuring devices and multi-function meter protection

Strong Points

- > Touch Safe
- > High breaking capacity (SCCR)
- > Modular
- > DIN rail mounting
- > Non-load disconnect

Compliance with Standards

- > UL 4248-4
Guide IZLT
File E307648
- > CSA-C22.2 No.
4248-07
Class 6225-01
File 265615



References

RM CC

Basic device Fuse size	30 A Class CC		30 A with LED Class CC	
	To be ordered in multiples of	Reference	To be ordered in multiples of	Reference
1 P	12	5705 0001	12	5705 0011
2 P	6	5705 0002	6	5705 0012
3 P	4	5705 0003	4	5705 0013

Accessories

Key Handle Padlocking System

Use

Padlocking of the handle (padlock not supplied).

Rating (A)	Quantity (units)	Reference ⁽¹⁾
30	5	5701 9040

(1) Not UL.



Coupling system

Rating (A)	Quantity (units)	Reference
30	12	5704 0003 ⁽¹⁾

(1) One coupling to attach two RM/CC.

Also sold in bags containing separate components (bags of 100 pieces) for assembling larger quantities. Please contact us.

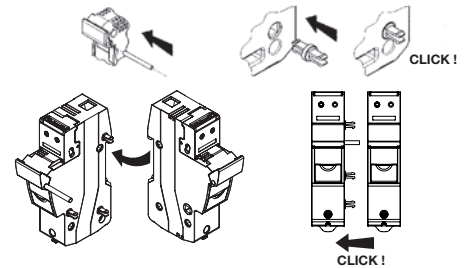

rm_060_a_1_LX_cat

Reinforced insulation kit

Rating (A)	Reference
30	5701 9010 ⁽¹⁾

(1) 1 reference = 1 set of 10 insulation kits



access_361_La

Characteristics

Characteristics according to UL 4248-4 and CSA-C22.2 No. 4248-07

Rated operational current (A)		30 A
Fuse size		class CC
Rated operating voltage (V)		600
Dielectric strength (V)		2200
LED working voltage ⁽¹⁾		120 ... 600 VAC
Rated power dissipation (W/P)		3
Protection degree		IP20
<i>(1) For fuse holders with LED indicator.</i>		
Class CC fuse protected short-circuit withstand		
Prospective short-circuit current (kA rms.)		200
Design current derating coefficient for N poles side by side		
N = 1 ... 3		1
N = 4 ... 6		0.8
N = 7 ... 9		0.7
N ≥ 10		0.6
Connection		
Wire type (solid / stranded Cu)		60 / 75°C
1 wire	Minimum Cu cable cross-section solid / stranded	18 AWG / 0.75 mm ²
	Maximum Cu cable cross-section solid / stranded	8 AWG / 16 mm ²
2 wires	Minimum Cu cable cross-section solid / stranded	18 AWG / 0.75 mm ²
	Maximum Cu cable cross-section solid	8 AWG / 10 mm ²
	Maximum Cu cable cross-section stranded	10 AWG / 10 mm ²
Wire strip (mm / in)		10 / 0.39
Maximum tightening torque		2.5 Nm / 22 lb.in
Fixing		DIN rail 35 mm DIN 46277/1-3 (EN50022)
Mechanical characteristics		
Weight of 1 P (lb / kg)		0.126 / 0.057
Weight of 2 P (lb / kg)		0.251 / 0.114
Weight of 3 P (lb / kg)		0.375 / 0.170

Dimensions (in / mm)

30 A

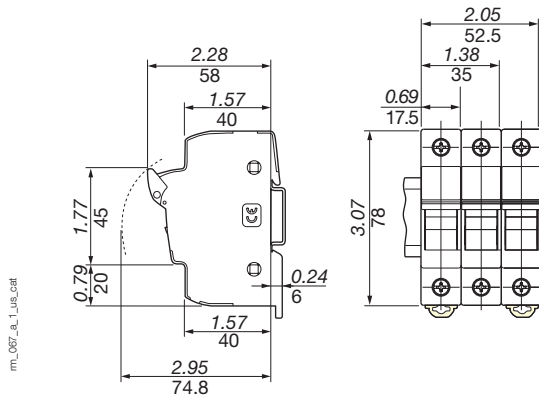

RM and RMS

Modular Fuse Holders

For Industrial and High Speed (uR) for Midget/Ferrule Fuses up to 125 A



The Solution For

- > Industrial control panels
- > Inverters
- > Measuring devices and multifunction meter production
- > UPS
- > Motor drives

Strong Points

- > Touch Safe
- > High breaking capacity (SCCR)
- > Modular
- > DIN rail mounting
- > Non-load disconnect
- > Pre-break capabilities, please consult us

Compliance with Standards

- > UL 4248-1, CSA-C22.2 No. 4248-1 Guide IZLT File E307648
- > IEC 60269-2-1



Approvals and certifications⁽¹⁾



⁽¹⁾ Product reference on request.

Function

RM and **RMS** are modular fuse holders for cylindrical fuses. They safely provide non-load disconnection and protection against overloads and short-circuits in any low voltage electrical circuit.

- RM: Non-signalling fuse holders for fuses without strikers
- RMS: Fuse disconnect switches with pre-break auxiliary contact, position and blown indication

Advantages

Improved safety

- Multipolar and simultaneous breaking
- High dielectric strength
- IP2X protection

High breaking capacity

Protection against overload and short-circuit events thanks to the high breaking capacity of fuses (100 kA rms).

Accessories

- Microswitchers for RMS 50 & 100A
- Padlocking capabilities
- Ganging kits to form multipolar from single poles
- Wiring combs

References

RM and RMS - Non-signalling device

Basic device Fuse size	32 A 10 x 38		50 A 14 x 51		100 A 22 x 58	
	To be ordered in multiples of	Reference	To be ordered in multiples of	Reference	To be ordered in multiples of	Reference
No. of poles						
1 P	12	5701 5015	6	5702 5001	6	5703 5001
1 P + N (1 module)	12	5701 5005 ⁽¹⁾				
1 P + N (2 modules)	6	5701 5017	3	5702 5005	3	5703 5005
1 P LED signalling	12	-	6	5702 5011	6	5703 0011
2 P	6	5701 0020	3	5702 5002	3	5703 5002
3 P	4	5701 0018	2	5702 5003	2	5703 5003
3 P + N	3	5701 0019	1	5702 5004	1	5703 5004
4 P			1	5702 5006	1	5703 5006
N	12	5701 0016	6	5702 5000	6	5703 5000-

(1) This device is not cURus.

RMS - Device with 1 signalling auxiliary contact (AC) ⁽¹⁾

Basic device Fuse size	50 A 14 x 51		100 A 22 x 58	
	To be ordered in multiples of	Reference	To be ordered in multiples of	Reference
No. of poles				
1 P	6	5702 5011	6	5703 5011
2 P	3	5702 5012	3	5703 5012
3 P	2	5702 5013	2	5703 5013
3 P + N	1	5702 5014	1	5703 5014
4 P	1	5702 5016	1	5703 5016

(1) The signalling auxiliary contact provides the pre-break, fuse presence and also blown fuse signal.

Something to think about



10x38 RMs equipped with 0.5 A Midget fuses to provide effective protection for voltage inputs and auxiliary power supplies for all our electronic devices (DIRIS, DIRIS Digiware, DIRIS DigiBOX, etc.)

RM and RMS

Modular Fuse Holders

For Industrial and High Speed (uR) for Midget/Ferrule Fuses up to 125 A

Accessories

Connection Accessories for RM 32 A 10 x 38

Comb bridging connection

Designation	Cross-section (mm ²)	Reference ⁽¹⁾
Unipolar comb with 12 modules	10	1749 0001
Unipolar comb with 13 modules	10	1749 0011
Unipolar comb with 57 modules	10	1749 0021
Unipolar comb with 12 modules	16	1749 0031
Unipolar comb with 13 modules	16	1749 0041
Unipolar comb with 57 modules	16	1749 0051
Nozzle		1749 8001

(1) Not UL.

Connection terminals

Designation	Reference ⁽¹⁾
Insulated neutral terminal for a 6 to 25-mm ² cable, side input	1749 9001
Insulated neutral terminal for a 6 to 50-mm ² cable, side input	1749 9002
Fully insulated power feed terminal for a 6 to 25-mm ² cable, side input	1749 9003
Right/left insulated terminal, 6 x 25 mm ²	1749 9004

(1) Not UL.

Auxiliary Contacts

Use

- 1 or 2 NO/NC auxiliary contacts:
- Pre-break, fuse presence and fuse blown signalling for RMS 50 and 100

Connection

By 0.25 in / 6.35 mm fast-on terminal

Characteristics		Operating current I_b (A) 250 VAC AC-13
Rating (A)	Contact type	
50 ... 100	NO/NC contact	2.5
50 ... 100	Two-level NO/NC contact	0.1

References		
NO/NC contact		
Rating (A)	Contact	Reference ⁽¹⁾
50	1 P with 1 AC	5702 9901
50	3 P with 1 AC	5702 9903
50	3 P with 2 AC	5702 9030
100	1 P with 1 AC	5703 9901
100	3 P with 1 AC	5703 9903
100	3 P with 2 AC	5703 9030

(1) Not UL.

Low level NO/NC auxiliary contact		
Rating (A)	Contact	Reference ⁽¹⁾
50	1 P with 1 AC	5702 9911
50	3 P with 1 AC	5702 9913
100	1 P with 1 AC	5703 9911
100	3 P with 1 AC	5703 9913

(1) Not UL.

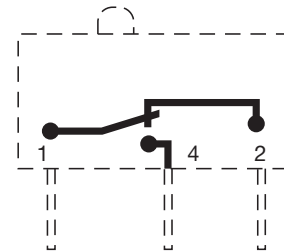
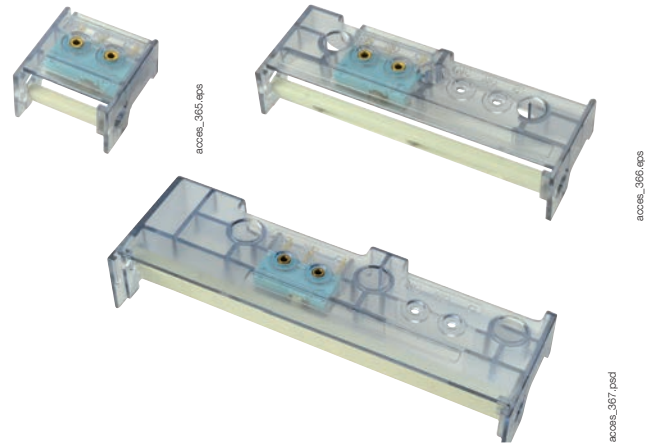
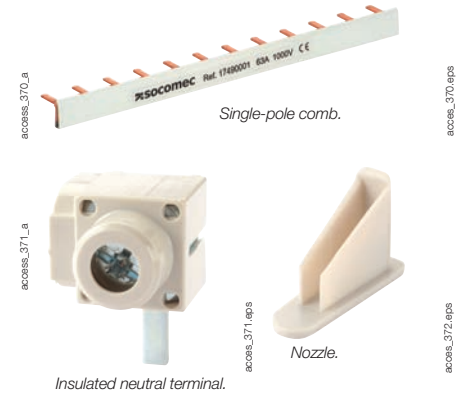

Padlocking Adapter

Use

Padlocking of the handle (padlock not supplied).

For RM and RMS		
Rating (A)	Quantity (units)	Reference ⁽¹⁾
32	5	5701 9040
50	5	5702 9040
100	5	5703 9040

(1) Not UL.

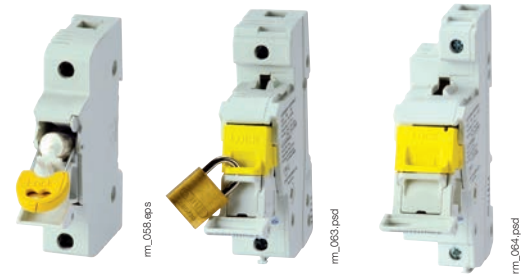

Coupling System for RM

For RM and RMS		
Rating (A)	Quantity (units)	Reference ⁽¹⁾
32	12	5704 0003 ⁽²⁾
50 ... 100	12	5702 9020 ⁽²⁾

(1) Not UL.

(2) One coupling device allows to link two RM/RMS.
Also sold in bags containing separate components
(bags of 100 pieces) for assembling larger quantities.
Contact us

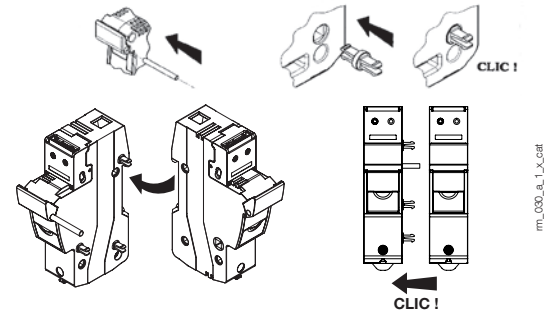

Reinforced Insulation Kit

Rating (A)	Reference ⁽¹⁾
32	5701 9010 ⁽²⁾

(1) Not UL.

(2) 1 reference = 1 set of 10 couplings.



RM and RMS

Modular Fuse Holders

For Industrial and High Speed (uR) for Midget/Ferrule Fuses up to 125 A

Characteristics according to UL 4248-1 and CSA-C22.2 No. 4248-1

30 to 100 A

Thermal operational current		30 A	50 A	100 A
Fuse size		Midget / 10 x 38	14 x 51	22 x 58
Rated operating voltage (V)		750	750	750
Rated fuse dissipated power (W/P)		3	5	12 W
Protection degree		IP20	IP20	IP20
gG fuse protected short-circuit withstand	Rated volatge			
Prospective short-circuit current (kA rms.) ⁽¹⁾	690 VAC	100	100	100
Prospective short-circuit current (kA rms.) ⁽¹⁾	400/500 VAC	120	120	120
Design current derating coefficient for N poles side by side				
N = 1 ... 3		1	1	1
N = 4 ... 6		0.8	0.8	0.8
N = 7 ... 9		0.7	0.7	0.7
N ≥ 10		0.6	0.6	0.6
Design current derating coefficient depending on the temperature				
20°C 68°F		1	1	1
30°C 86°F		0.95	0.95	0.95
40°C 104°F		0.90	0.90	0.90
50°C 122°F		0.80	0.80	0.80
60°C 140°F		0.70	0.70	0.70
70°C 158°F		0.60	0.60	0.60
Connection				
Minimum Cu cable cross-section SOLID / STRANDED		0.75 mm ² / 18 AWG	1.5 mm ² / 16 AWG	1.5 mm ² / 16 AWG
Maximum Cu cable cross-section SOLID		16 mm ² / 8 AWG	35 mm ² / 8 AWG	50 mm ² / 1 AWG
Maximum Cu cable cross-section STRANDED		16 mm ² / 8 AWG	25 mm ² / 6 AWG	35 mm ² / 2 AWG
Tightening torque		2.5 Nm / 22 lb.in	3 Nm / 26 lb.in	4 Nm / 35 lb.in
Dimensional data				
Weight of 1 P / N (kg/lb)		0.125 / 0.0132 lb 0.057 / 0.06 kg	0.22 lb 0.1 kg	0.342 lb 0.155 kg
Weight of 1 P + N (kg/lb)		0.258 lb 0.117 kg	0.473 lb 0.215 kg	0.721 lb 0.327 kg
Weight of 3 P + N (kg/lb)		0.505 lb 0.229 kg	0.915 lb 0.415 kg	1.393 lb 0.632 kg

(1) Connection for RM32 1 P + N (1 module).

Characteristics according to IEC 60269-2

32 to 100 A

Thermal current I _m (20°C/68°F)	32 A	50 A	100 A
Fuse size	10 x 38	14 x 51	22 x 58
Rated insulation voltage U _i (V)	690	690	690
Fuse rating (A)			
at 400 VAC	32	50	125
at 500 VAC	32	50	125
at 690 VAC		50	125

Dimensions

RM 32 A unipolar and multipolar

RM 32 A Ref.: 5701 5005

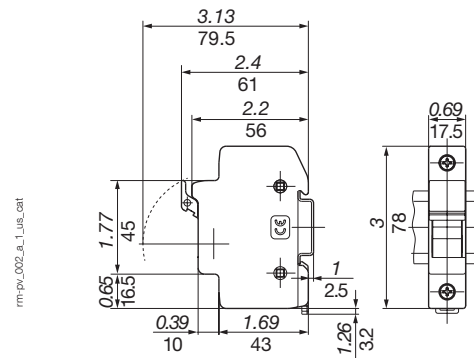
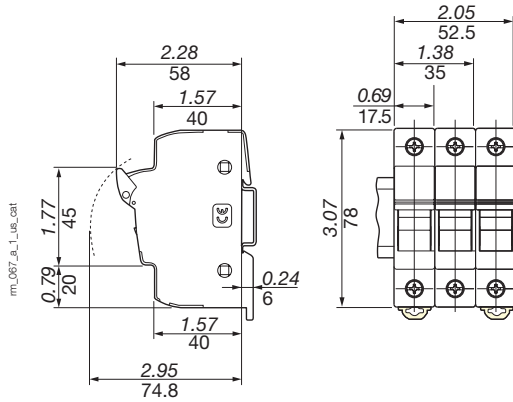

RMS 50/100 A unipolar and multipolar

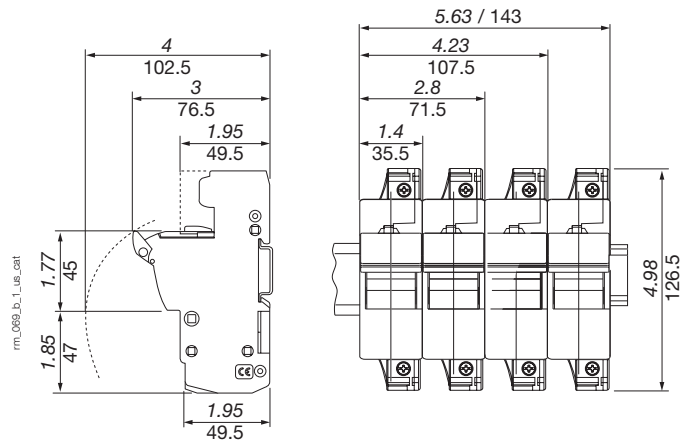
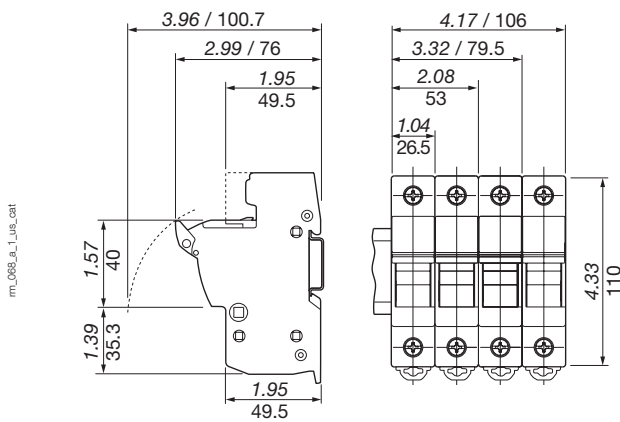

Fuse Combination Switches

For Specific Applications

Despite already offering a wide range of fuse combination switches, SOCOMEC also manufactures specific products suitable for all your requirements and dedicated to specific applications. Some of these products can be seen on these two pages, however this list does not include them all. Please contact us for more information.

Fused Changeover Switches



Available from 600⁽¹⁾ to 800 A, the **FUSERBLOC changeover switch** range is a great solution for safe guarding of energy supply, protection and disconnection of stand-by pumps and other sensitive loads.

(1) Other ratings: please consult us.

Factory mounted UL 98 certified 600 A and 800 A fusible changeover switches with three stable positions:

I – 0 – II and padlockable in OFF position.

References for UL listed fused changeover switches

Rating (A)	No. of poles	Fuse	Reference	External operation handle	Shaft
600 A	2 P	Class J	3881 2060	S4 type, 4,4X, Black 144D 3113	320 mm 1401 1532
	3 P		3881 3060		
	4 P		3881 4060		
800 A	2 P	Class L	3881 2080		400 mm 1401 1540
	3 P		3881 3080		
	4 P		3881 4080		

Dimensions

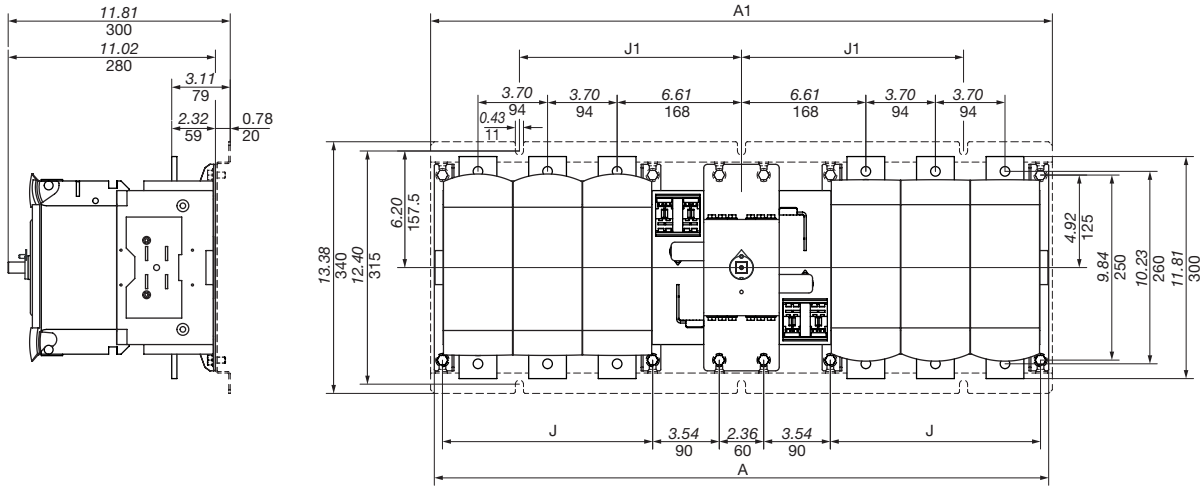

fuseru1_024_a_1_x_cat.a

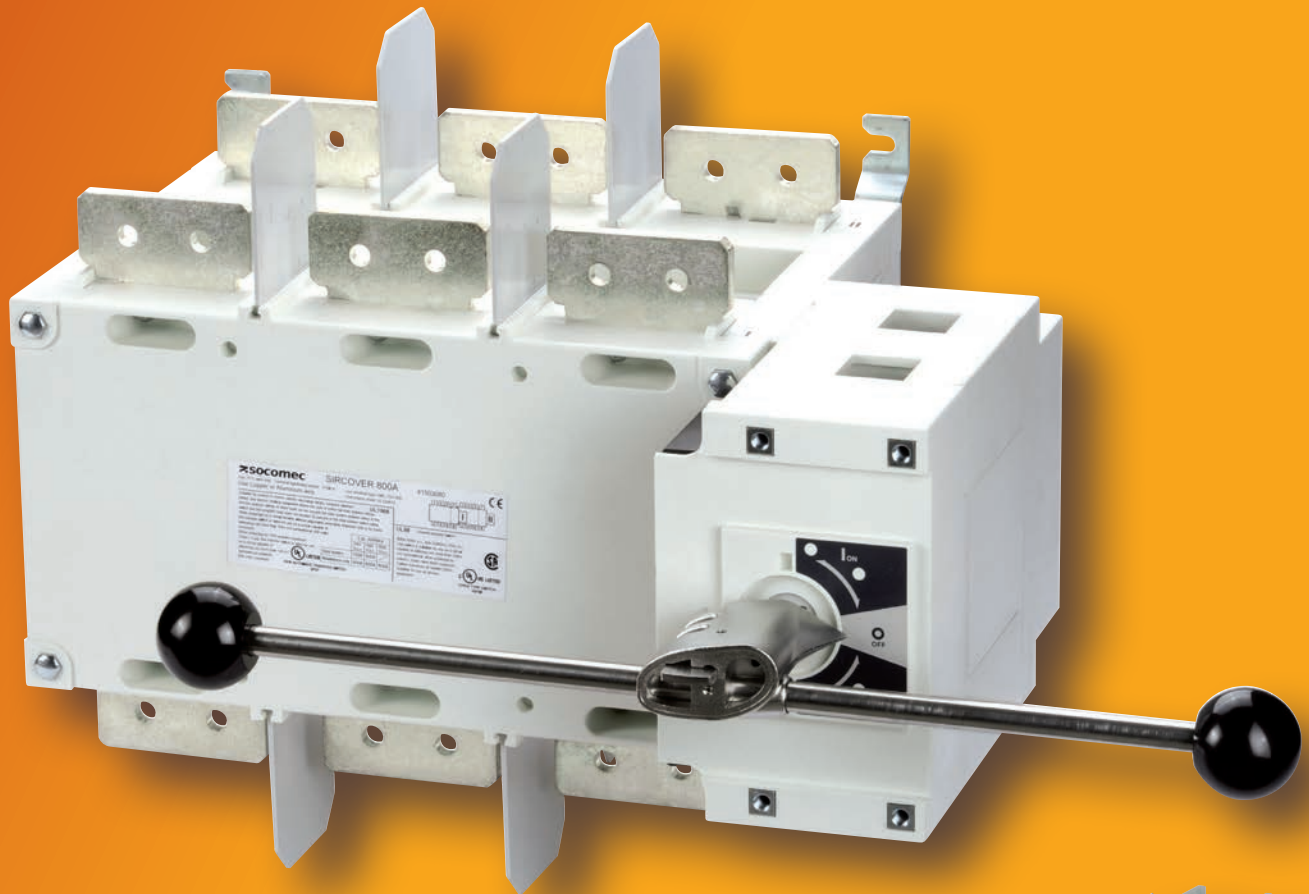

Transfer switches

Manual & non-automatic transfer switches p. 132

Manual transfer switches



COMO CS
25 to 100 A
p. 134



SIRCOVER UL 98/1008
100 to 1200 A
p. 140

Non-automatic transfer switches



ATyS UL 1008
100 to 1200 A
p. 152

Automatic transfer switches



ATyS FT
100 to 400 A
p. 162



ATyS DT
100 to 400 A
p. 162

ATS controller



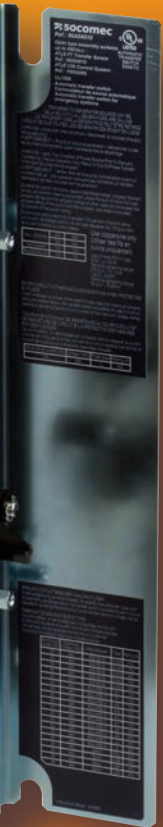

ATyS 66
p. 170



Manual, non-automatic & automatic transfer switches

A range of manual, non-automatic and automatic transfer switches up to 1200 A

MTSE (Manual)	RTSE (Remotely operated)	ATSE (Automatically operated)
 <p data-bbox="240 1045 529 1136"> SIRCOVER UL 1008 Manual transfer switching equipment </p>	 <p data-bbox="683 1045 967 1136"> ATyS UL 1008 Non-automatic transfer switching equipment </p>	 <p data-bbox="1122 1045 1409 1136"> ATyS Ft - ATyS DT Automatic transfer switching equipment </p>

Typical applications

The transfer switches 1008 range provides safe transfer for mains/genset and genset/genset applications.

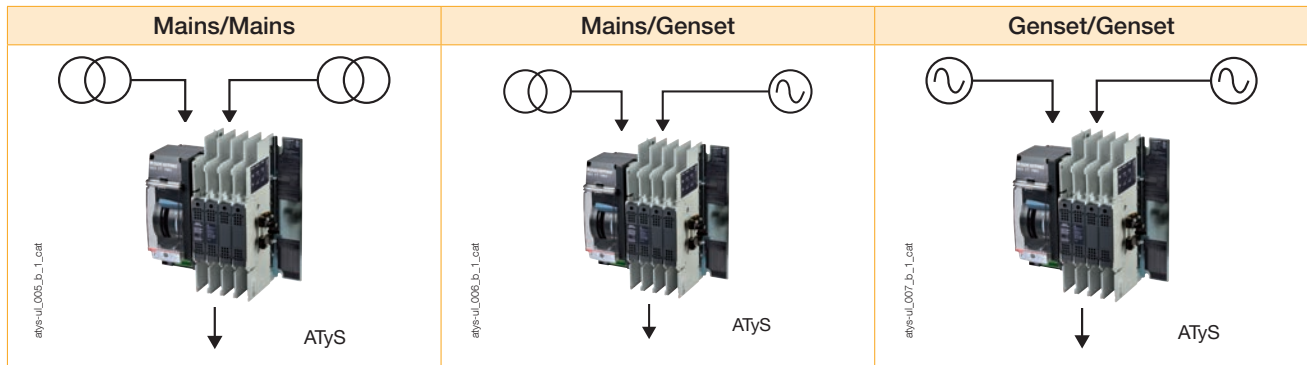

COMO CS

Manual Cam changeover switches
from 25 to 100 A



COMO CS - Door mounting
I-II 3 P 25 A



COMO CS in enclosure
I-0-II 3 P 40 A

Function

COMO CS are manually operated multi-pole changeover switches. They ensure switching, transfer of sources or transfer of two low voltage circuits on load as well as their safe disconnection.

Advantages

Simple installation

The “quick fix” allows significant time saving in fixing the handle to the device. The devices sold in enclosed version are ready for installation.

Quick mounting

The accessories offered are common to all the products in the range. The products are designed for installation:

- on the rear of the cabinet on a backplate,
- on the rear of the cabinet on a DIN rail,
- on the door with a direct handle.

Effective in all circumstances

The devices are available with 3 standard switching types that can cover a wide variety of applications:

- I-II
- I-0-II
- I-0-II with bypass

Please consult us for adaptations to specific wiring diagrams.

The solution for

- > OEM/Machine Builders
- > Industrial Control Panel Manufacturers (UL 508A)
- > Switchboard Manufacturers (UL 891)
- > Distributors



Strong points

- > Simple installation
- > Quick mounting

Compliance with standards

- > UL 60947-4-1
CSA-C22.2 No. 60947-4-1⁽¹⁾
Guide NLRV
File E173959
- > UL 60947-4-1
Guide NRNT
File E237502
- > IEC 60947-3



(1) 25A only.

Configurations

Backplate switch mounted with external handle

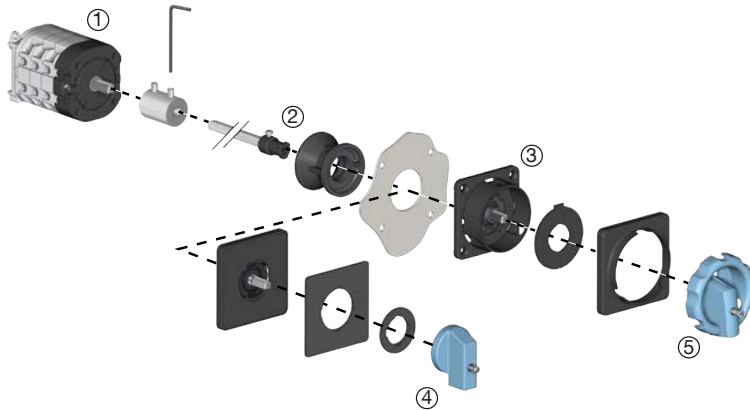

Functional diagram (for further details see the installation instructions supplied with the product).

1. Shaft extension
2. Shaft guide

3. Signalling plate
4. Non padlockable handle
5. Padlockable handle

Direct quickfixing handle for door or backplate mounted switch

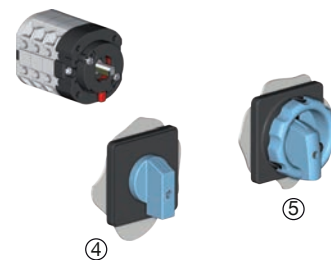

como-enc_025_a_1_x_cst1a1

References

COMO CS

Backplate mounting with direct quickfixing handles or external handles

Rating (A)	N° of poles	Switching type	Switch body rear mounting ⁽¹⁾	Padlockable direct quick fixing handle	Non-padlockable direct quick fixing handle	Padlockable external handle ⁽²⁾	Non-padlockable external handle ⁽²⁾
25 A	3 P	I - II	4320 3002	Blue/Black 4359 3042 Red/Yellow 4359 3043	Blue/Black 4359 3022	Blue/Black 4359 1042 Red/Yellow 4359 1043	Blue/Black 4359 2022
	4 P	I - II	4320 4002				
	3 P	I - 0 - II	4330 3002				
	4 P	I - 0 - II	4330 4002				
	3 P	Bypass I - 0 - II	4350 3002				
	4 P	Bypass I - 0 - II	4350 4002				
40 A	3 P	I - II	4320 3004				
	4 P	I - II	4320 4004				
	3 P	I - 0 - II	4330 3004				
	4 P	I - 0 - II	4330 4004				
	3 P	Bypass I - 0 - II	4350 3004				
	4 P	Bypass I - 0 - II	4350 4004				
63 A*	3 P	I - II	4320 3006				
	4 P	I - II	4320 4006				
	3 P	I - 0 - II	4330 3006				
	4 P	I - 0 - II	4330 4006				
	3 P	Bypass I - 0 - II	4350 3006				
	4 P	Bypass I - 0 - II	4350 4006				
100 A*	3 P	I - II	4320 3010				
	4 P	I - II	4320 4010				
	3 P	I - 0 - II	4330 3010				
	4 P	I - 0 - II	4330 4010				
	3 P	Bypass I - 0 - II	4350 3010				
	4 P	Bypass I - 0 - II	4350 4010				

(1) Mounting on DIN rail and backplate from 25 to 40 A and mounting on backplate for ratings from 63 to 100 A.

(2) Delivered with shaft and plate for front external operation.

* CSA rating for 25A

Door mounting with direct quickfixing handles

Rating (A)	N° of poles	Switching type	Switch body mounting on door	Padlockable direct quick fixing handle	Non-padlockable direct quick fixing handle
25 A	3 P	I - II	4320 3102	Blue/Black 4359 3042 Red/Yellow 4359 3043	Blue/Black 4359 3022
	4 P	I - II	4320 4102		
	3 P	I - 0 - II	4330 3102		
	4 P	I - 0 - II	4330 4102		
	3 P	Bypass I - 0 - II	4350 3102		
	4 P	Bypass I - 0 - II	4350 4102		
40 A	3 P	I - II	4320 3104		
	4 P	I - II	4320 4104		
	3 P	I - 0 - II	4330 3104		
	4 P	I - 0 - II	4330 4104		
	3 P	Bypass I - 0 - II	4350 3104		
	4 P	Bypass I - 0 - II	4350 4104		
63 A	3 P	I - II	4320 3106		
	4 P	I - II	4320 4106		
	3 P	I - 0 - II	4330 3106		
	4 P	I - 0 - II	4330 4106		
	3 P	Bypass I - 0 - II	4350 3106		
	4 P	Bypass I - 0 - II	4350 4106		
100 A *	3 P	I - II	4320 3110		
	4 P	I - II	4320 4110		
	3 P	I - 0 - II	4330 3110		
	4 P	I - 0 - II	4330 4110		
	3 P	Bypass I - 0 - II	4350 3110		
	4 P	Bypass I - 0 - II	4350 4110		

* CSA rating for 25A and 40A only

COMO CS

Manual Cam changeover switches
from 25 to 100 A

Other solutions with enclosures

General characteristics



como-enc_018.jpg

- Available for switching types I-II and I-0-II
- Different enclosure sizes adapted to your needs.
 - Maximum safety during maintenance operations due to triple padlocking of the handle in position 0 (position I for switching type I-II).
 - NEMA 4, 4X / IP 65 when installed in an industrial environment, protection degree NEMA 4, 4X / IP 65 ensures that the products are protected against dust and water jets.
 - Red-yellow operating handle.

References

Rating (A)	No. of poles	Switching type	Reference
25 A	3 P	I - II	4321 3C02
	4 P	I - II	4321 4C02
	3 P	I - 0 - II	4331 3C02
	4 P	I - 0 - II	4331 4C02
40 A	3 P	I - II	4321 3C04
	4 P	I - II	4321 4C04
	3 P	I - 0 - II	4331 3C04
	4 P	I - 0 - II	4331 4C04

* For an ambient temperature of 95 °F / 35 °C

Dimensions (in/mm)

25 to 40 A

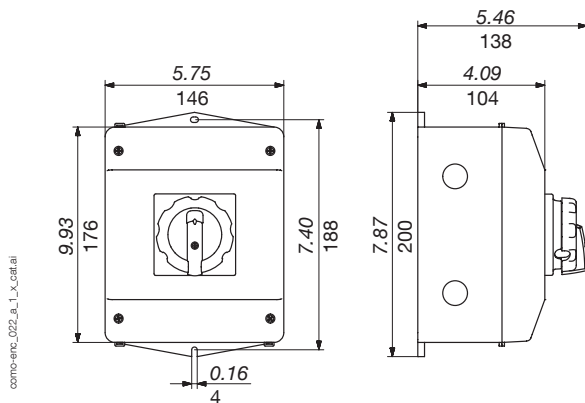

como-enc_022_a_1_1_0_cat.fr

Characteristics according to UL 60947-4-1 and CSA-C22.2 No. 60947-4-1⁽¹⁾
25 to 100 A

General use rating (A)	25 A	40 A	63 A	100 A
UL certification file	88EJ		5LM6	
Short circuit rating at 600 VAC (kA)	10	5	/	
Type of fuse	RK5		/	
Max fuse rating (A)	150		/	
Max horsepower rating (HP)				
120 VAC / 1 phase	-	2	/	
120 VAC / 3 phase	-	5	/	
240 VAC / 1 phase	-	3	/	
240 VAC / 3 phase	-	10	/	
480 VAC / 3 phase	-	20	/	
600 VAC / 3 phase	5,2	20	/	
Connection terminals				
Solid wire (AWG)	#14 - #12	#14 - #8	#14 - #4	#10 - #2
Wire stripping distance (in/mm)	0.31 / 8	0.39 / 10	0.51 / 13	0.51 / 13
Mechanical characteristics				
Durability (number of operating cycles)	100 000	100 000	100 000	100 000
Tightening torque (Lb.in / N.m)	8.8 / 1	13.3 / 1.5	22,1 / 2.5	13.3 / 1.5
Weight of a 3 pole device (lb)	0.24	0.4	1	1
Weight of a 4 pole device (lb)	0.28	0.49	1.18	1.18

⁽¹⁾ 25A only.

Characteristics according to IEC 60947-3
25 to 100 A

Conventional free air thermal current I_{th} at 40 °C (A)	25 A	40 A	63 A	100 A
Conventional free air thermal current I_{th} at 50 °C (A)	25	34	63	100
Conventional free air thermal current I_{th} (60 °C) (A)	19	24	53	90
Rated insulation voltage U_i (V)	690	690	690	690
Rated impulse withstand voltage U_{imp} (kV)	4	6	6	6
Rated operational currents I_g (A)				
Utilisation category at 400 VAC				
AC-21A	25	40	63	100
AC-22A	20,5	40	63	100
AC-23A	15	29	63	63
AC-3	12	22		
Utilisation category at 690 VAC				
AC-21A	25	40	/	/
AC-22A	20,5	40	/	/
AC-23A	8,5	17	/	/
AC-3	7	12,8	/	/
Operational power in AC-23 (kW)⁽¹⁾				
At 400 VAC without pre-break AC	7,5	15	37	37
At 690 VAC without pre-break AC	4,8	15	/	/
Fuse protected short-circuit withstand with gG DIN fuses				
Prospective short-circuit (kA rms)	7	10	5	5
Associated fuse rating (A)	25	40	63	100
Rated operational voltage (Va.c)	690	690	415	415
Connection				
Minimum CU cable cross-section (mm ²)	0,5	1	1.5	4
Smaximum CU cable cross-section (mm ²)	4	10	16	35
Tightening torque min - max (Nm)	0.8-1.2	1.2-1.5	2.5	1.5
Mechanical characteristics				
Durability (number of operating cycles)	100 000	100 000	100 000	100 000
Weight of a 3 pole device (lb)	0.24	0.41	0.97	0.97
Weight of a 4 pole device (lb)	0.29	0.49	1.18	1.18

⁽¹⁾ The power is given for information only, the current values vary from one manufacturer to another.

Dimensions (in/mm)

25 to 100 A

Mounting on door - Fixing with direct handle

Door width		
Unit	Mini	Maxi
in	0.04	1
mm	0.16	4

Rating (A)	Unit	I-II / I-0-II		Bypass I-0-II		C	D
		3 P	4 P	3 P	4 P		
25	in	3.19	3.66	4.13	4.61	1.54	1.57
	mm	81	93	105	117	39	40
40	in	3.31	4.82	4.33	4.84	2.11	2.2
	mm	84	97	110	123	53.6	56
63 - 100	in	4.45	5.28	6.1	6.93	2.91	2.8
	mm	113	134	155	176	74	71

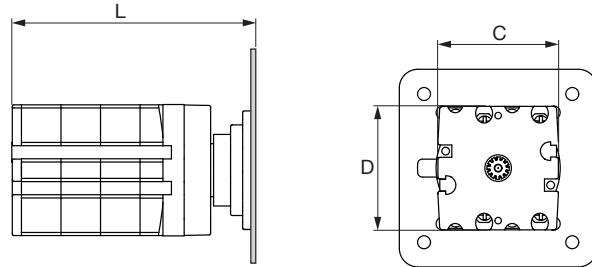

como_261_a_1_x_cat.ai

Mounting on backplate / DIN rail - Rear fixing of direct handle

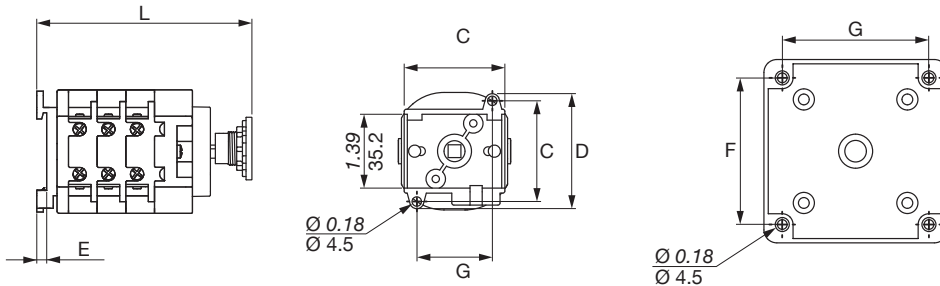

como_262_a_1_x_cat.ai

Rating (A)	Unit	I-II / I-0-II		Bypass I-0-II		E	C	D	F	G
		3 P	4 P	3 P	4 P					
25	in	3.20	3.68	4.15	4.57	0.18	1.89	2.2	1.65	1.42
	mm	81.4	93.4	105.4	116.1	4.5	48	56	47	36
40	in	3.73	4.28	4.28	5.08	0.18	1.89	2.2	1.65	1.42
	mm	94.7	107.7	120.7	129	4.5	48	56	47	36
63 ... 100	in	5.10	5.97	6.83	7.54	-	2.99	2.99	2.68	2.68
	mm	129.5	151.5	173.5	191.5	-	76	76	68	68

Mounting on backplate / DIN rail - Rear fixing of external handle

Rating (A)	Unit	X-L ⁽³⁾		C		D	
		I-II / I-0-II	Bypass I-0-II	3 P	4 P		
25	in	3.19	3.66	4.13	4.61	1.54	1.57
	mm	81	93	105	117	39	40
40	in	3.31	4.82	4.33	4.84	2.11	2.2
	mm	84	97	110	123	53.6	56
63...100	in	4.45	5.28	6.1	6.93	2.91	2.8
	mm	113	134	155	176	74	71

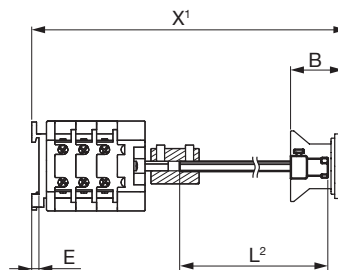

como_263_a_1_x_cat.ai

- (1) X is the distance between the inside of the door and the fixing plate
- (2) L is the total length of the shaft (max 200 mm)
- (3) Minimum distance between the inside of the door and the fixing plate

Dimensions for handles

25 to 100 A

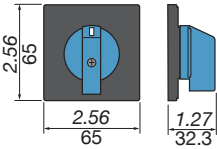
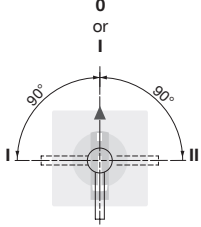
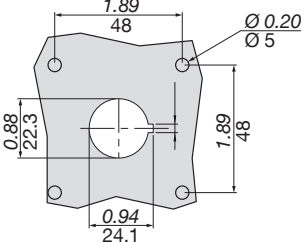
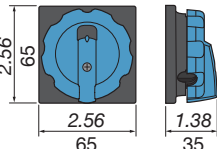
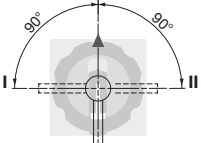
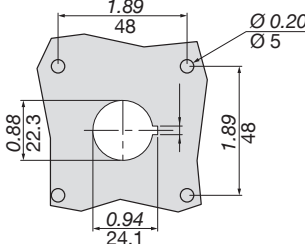
Handle type	Front operation Direction of operation	Door drilling
<p>K1 type non padlockable</p>  <p>2.56 65 2.56 65 1.27 32.3</p>	<p>0 or I</p>  <p>90° 90° I II</p>	 <p>1.89 48 Ø 0.20 Ø 5 0.88 22.3 1.89 48 0.94 24.1</p>
<p>K1 type padlockable</p>  <p>2.56 65 2.56 65 1.38 35</p>	<p>0 or I</p>  <p>90° 90° I II</p>	 <p>1.89 48 Ø 0.20 Ø 5 0.88 22.3 1.89 48 0.94 24.1</p>

poign_075_a_1_gp_cat.ai

poign_076_a_1_gp_cat.ai

SIRCOVER UL 98/1008

Manually operated transfer switching equipment
from 100 to 1200 A

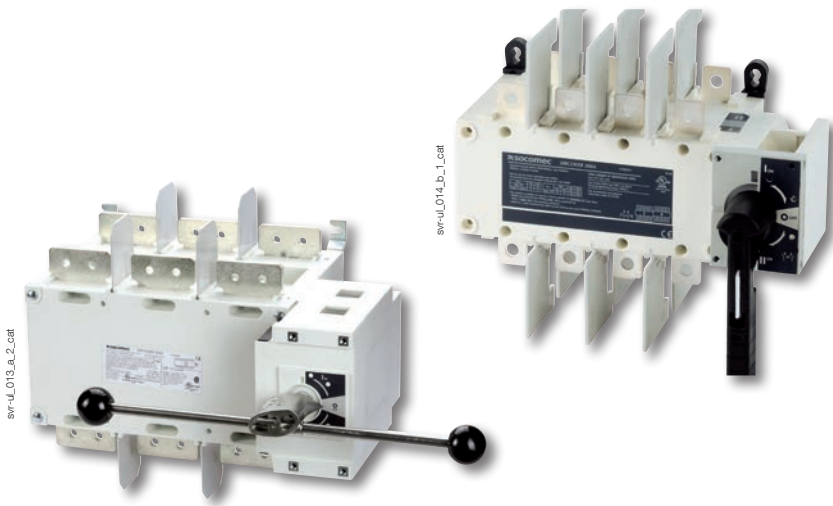

Function

SIRCOVER UL 98/1008 are heavy duty manual transfer switches. They ensure switching transfer of sources or transfer of two low voltage circuits on load as well as their safe disconnection.

These switches are extremely durable and are tested and approved for use in the most demanding applications, such as resistive load or total system applications.

Advantages

Stable positions

SIRCOVER UL has three stable positions which are not affected by voltage drops or vibrations, thus protecting your load against network interference.

Compact design

The SIRCOVER UL is based on a back-to-back switching technology, providing a compact solution.

On-load switching

The SIRCOVER UL enables secure and reliable switching, without the need for pre-breaking upstream.

Reliability

The SIRCOVER UL has double breaking per pole achieved through its sliding bar contacts system. The quick opening and rapid closure provides simultaneous disconnecting or making of all power contacts.

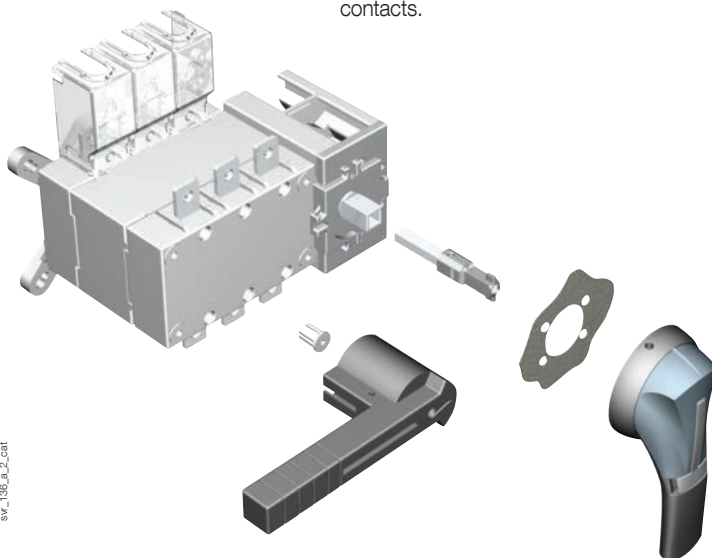

The solution for

- > Standby power builders
- > OEM/Machine Builders
- > Industrial Control Panel Manufacturers (UL 508A)
- > Switchboard Manufacturers (UL 891)
- > Distributors



Strong points

- > Stable positions
- > Compact design
- > On-load switching
- > Reliability

Conformity to standards

- > UL 1008
Guide WPYV
File E317092



- > UL 98
Guide WHTY
File E201138



- > CSA-C22.2 No. 4
Class 4651-02
File 112964

UL 98 and CSA from 600-1200 A. Specific reference from 100 to 400 A on request.

Enclosed solutions

The SIRCOVER UL is also offered enclosed, please consult us for more information.



Enclosed
SIRCOVER

Typical application

The SIRCOVER UL 98/1008 range provides safe transfer and disconnection within your LV installation for optional standby systems (as described in NEC Article 702).

Standard applications also include:

- Transfer from Normal power supply to the backup genset source (emergency supply).
- Safe on load transfer.
- Changing motor phase rotation and equipment grounding connection.

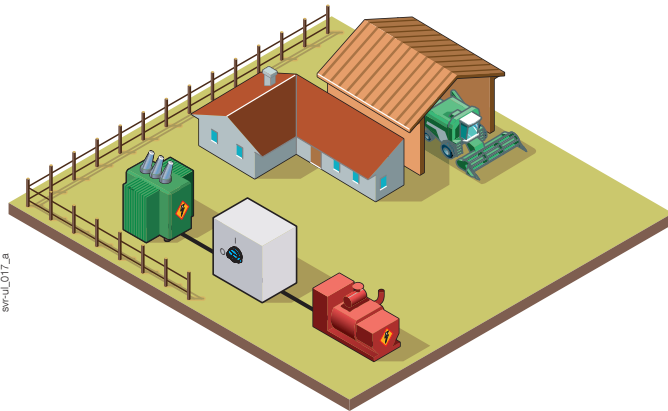

svr-ul_017_a

The SIRCOVER UL 98/1008 can also be used as switching means to a temporary power supply in emergency systems (systems needed for human safety) as described in article 700.3(F) of the NEC (see example below "switching means and interlock").

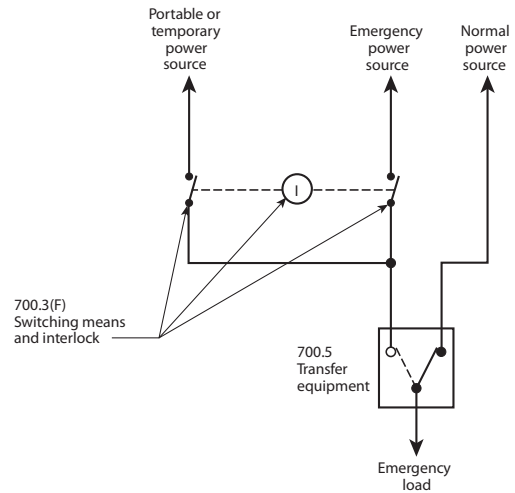

svr-ul_018_a_1_us_cat.a

Example of connection for temporary or portable power ⁽¹⁾.

(1) National Fire Protection Agency, NFPA 70: National Electrical Code®. 2017 Edition. Quincy, MA: National Fire Protection Agency, 2016, p. 70-581.

SOCOMEc solution up to 1200 A

svr-ul_014_b_2_cat



UL 1008 Manual Transfer Switch

From **100 to 400 A** for resistive and total systems applications.
 UL 98 / CSA 22.2 No. 4 versions on request.

svr-ul_013_a_2_cat

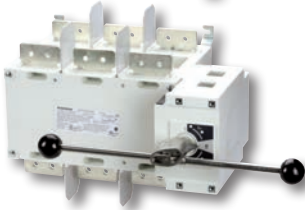

UL 1008 and UL 98 Manual Transfer Switch

From **600 to 1200 A** for resistive and total systems applications.
 Has UL 98/CSA 22.2 No. 4 certification.

IEC solution up to 3200 A

The SIRCOVER UL 1008 is part of a large range that includes IEC products of standalone, enclosed manual transfer switches and manual bypass switches with overlapping options. Contact us for further information on our complete range.



SIRCOVER UL 98/1008

Manually operated transfer switching equipment
from 100 to 1200 A

References

SIRCOVER UL 98/1008

Rating (A)	Frame size	No. of poles	Switch body	Direct handle	External handle	Shaft for external handle	Bridging bars	Auxiliary contacts	Terminal screens		
100 A*	B4	2 P	4150 2012	Black 4199 4012	S2 type Black I - 0 - II 4, 4X 142D 2113	S2 type 200 mm 7.9 inches 1400 1020	2 P 4159 2021 3 P 4159 3021 4 P 4159 4021	Contact NO/NC 4159 0021 Low level 4159 0022	2 / 3 P 4158 3021 4 P 4158 4021		
		3 P	4150 3012								
		4 P	4150 4012								
200 A*		2 P	4150 2022							320 mm 12.6 inches 1400 1032	400 mm 15.7 inches 1400 1040
		3 P	4150 3022								
		4 P	4150 4022								
260 A*	B5	2 P	4150 2026	S2 type Black I - 0 - II 4, 4X 142D 2113	S2 type 200 mm 7.9 inches 1400 1020	2 P 4159 2041 3 P 4159 3041 4 P 4159 4041	Contact NO/NC 4159 0021 Low level 4159 0022	2 / 3 P 4158 3041 4 P 4158 4041			
		3 P	4150 3026								
		4 P	4150 4026								
400 A*		2 P	4150 2042						S3 type Black I - 0 - II 4, 4X 143D 3113	320 mm 12.6 inches 1400 1032	400 mm 15.7 inches 1400 1040
		3 P	4150 3042								
		4 P	4150 4042								
600 A	B6	3 P	4150 3060	S3 type Black I - 0 - II 4, 4X 143D 3113	S3, S4 type 200 mm 7.9 inches 1401 1520	3 P 4159 3063 4 P 4159 4063	Contact NO/NC as standard	3 P 1609 3063 4 P 1609 4063			
		4 P	4150 4060								
800 A	B7	3 P	4150 3080	S4 type Black I - 0 - II 4, 4X 144D 3813 ⁽¹⁾	320 mm 12.6 inches 1401 1532	400 mm 15.7 inches 1401 1540	3 P 4159 3080 4 P 4159 4080	Contact NO/NC as standard	3 P 1609 3080 4 P 1609 4080		
		4 P	4150 4080								
1200 A		3 P	4150 3120								
		4 P	4150 4120								

Common accessories - more available on next pages.

* From 100 to 400 A, UL 98/CSA-C22.2 No. 4 Specific reference upon request.

Direct handle

Rating (A)	Type	Color	Handle type	Reference
100 ... 400	B3	Black	1 lever	4199 4012
600	J4	Black	2 levers	4199 7012
800 ... 1200	V1	Metal	2 levers	4199 7062

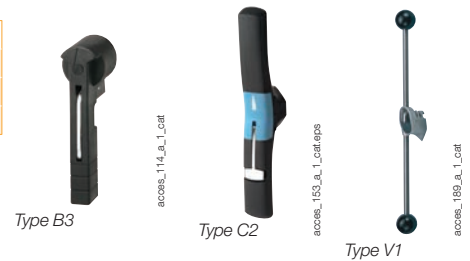

External handle

Rating (A)	Handle type	Color	Nema type	Lockable in 3 positions	Reference
100 ... 400	S2	Black	4, 4X	no	142D 2113
100 ... 400	S2	Red/Yellow	4, 4X	no	142E 2113
100 ... 400	S2	Black	1, 3R, 12	no	142F 2113
100 ... 400	S2	Red/Yellow	1, 3R, 12	no	142G 2113
100 ... 400	S2	Black	4, 4X	yes	142D 2813
100 ... 400	S2	Red/Yellow	4, 4X	yes	142E 2813
100 ... 400	S2	Black	1, 3R, 12	yes	142F 2813
100 ... 400	S2	Red/Yellow	1, 3R, 12	yes	142G 2813
260 ... 600	S3	Black	4, 4X	no	143D 3113
260 ... 600	S3	Red/Yellow	4, 4X	no	143E 3113
260 ... 600	S3	Black	1, 3R, 12	no	143F 3113
260 ... 600	S3	Red/Yellow	1, 3R, 12	no	143G 3113
260 ... 600	S3	Black	4, 4X	yes	143D 3813
260 ... 600	S3	Red/Yellow	4, 4X	yes	143E 3813
260 ... 600	S3	Black	1, 3R, 12	yes	143F 3813
260 ... 600	S3	Red/Yellow	1, 3R, 12	yes	143G 3813
800 ... 1200	S4	Black	4, 4X	no	144D 3113
800 ... 1200	S4	Black	1, 3R, 12	no	144E 3113
800 ... 1200	S4	Black	1, 3R, 12	no	144E 3113
800 ... 1200	S4	Red/Yellow	1, 3R, 12	no	144G 3113
800 ... 1200	S4	Black	4, 4X	yes	144D 3813
800 ... 1200	S4	Red/Yellow	4, 4X	yes	144E 3813
800 ... 1200	S4	Black	1, 3R, 12	yes	144F 3813
800 ... 1200	S4	Red/Yellow	1, 3R, 12	yes	144G 3813

Use

The handle interlocking function prevents the user from opening the door of the enclosure when the switch is in the "ON" position.

Opening the door when the switch is in the "ON" position is possible by defeating the interlocking function with the use of a tool (authorized persons only).

The interlocking function is restored when the door is re-closed.



Shaft for external handle

Rating (A)	Handle type	Length (in)	Length (mm)	Dimension X (in)	Dimension X (mm)	Reference
100 ... 400	S2	7.9	200	10 ... 14.3	254 ... 362	1400 1020
100 ... 400	S2	12.6	320	10 ... 19	254 ... 482	1400 1032
100 ... 400	S2	15.7	400	10 ... 22.1	254 ... 562	1400 1040
260 ... 400	S3	7.9	200	12 ... 18.4	305 ... 467	1401 1520
260 ... 400	S3	12.6	320	12 ... 23.1	305 ... 587	1401 1532
260 ... 400	S3	15.7	400	12 ... 26.3	305 ... 667	1401 1540
260 ... 600	S3	7.9	200	20 ... 23.4	508 ... 594	1401 1520
260 ... 600	S3	12.6	320	20 ... 28.1	508 ... 714	1401 1532
260 ... 600	S3	15.7	400	20 ... 31.3	508 ... 794	1401 1540
800 ... 1200	S4	7.9	200	20 ... 23.4	508 ... 594	1401 1520
800 ... 1200	S4	12.6	320	20 ... 28.1	508 ... 714	1401 1532
800 ... 1200	S4	15.7	400	20 ... 31.3	508 ... 794	1401 1540

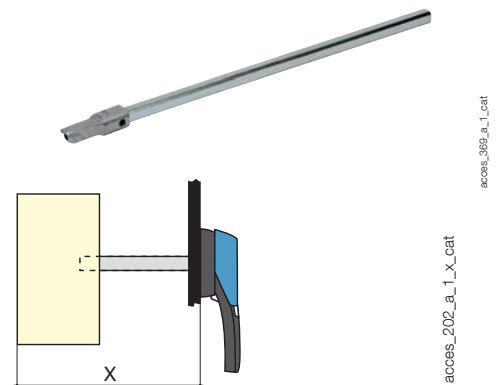

SIRCOVER UL 98/1008

Manually operated transfer switching equipment
from 100 to 1200 A

Bridging bars

Use

Creation of a common point, above or below the switch, between positions I and II. Please check the number of poles needed.

Rating (A)	No. of poles	Reference
100 ... 200	2 P	4159 2021
100 ... 200	3 P	4159 3021
100 ... 200	4 P	4159 4021
260 ... 400	2 P	4159 2041
260 ... 400	3 P	4159 3041
260 ... 400	4 P	4159 4041
600	3 P	4159 3063
600	4 P	4159 4063
800 ... 1200	3 P	4159 3080
800 ... 1200	4 P	4159 4080



access_205_a_1_cat

Terminal protection screen

Use

Each part number includes top and bottom protection against direct contact with terminals or connecting parts.

Rating (A)	No. of poles	Reference
100 ... 200	2/3 P	4158 3021
100 ... 200	4 P	4158 4021
260 ... 400	2/3 P	4158 3041
260 ... 400	4 P	4158 4041
600	3 P	1609 3063
600	4 P	1609 4063
800 ... 1200	3 P	1609 3080
800 ... 1200	4 P	1609 4080



access_207_a_1_cat

Auxiliary contacts

Use

Pre-break and signalization of positions for general applications of 125-250VAC, 60Hz, general use 10A, 1A 1/2 HP.

For low level the applications 125VAC, 60Hz, general use 1A.

Electrical characteristics

A300.

NO/NC auxiliary contact

Rating (A)	Contact (s)	Reference
100 ... 400	NO/NC on position 1 and 2	4159 0021
100 ... 400	Low level NO/NC on position 1 and 2	4159 0022
600 ... 1200	NO/NC on position 1 and 2	as standard



access_065_a_1_cat

access_065_a_1_cat

Terminal lugs

Use

Connection of bare copper cables onto the terminals (without lugs).

Rating (A)	Wires range	No wires per lug	Lugs per kit	Wires	Reference
100 ... 200	6 - 300MCM	1	2	Cu / Al	3954 2020
100 ... 200	6 - 300MCM	1	3	Cu / Al	3954 3020
100 ... 200	6 - 300MCM	1	4	Cu / Al	3954 4020
260 ... 400	4 - 600MCM	1	2	Cu / Al	3954 2040
260 ... 400	4 - 600MCM	1	3	Cu / Al	3954 3040
260 ... 400	4 - 600MCM	1	4	Cu / Al	3954 4040
600	2x (#2 - 600MCM)	2	3	Cu / Al	3954 3060
600	2x (#2 - 600MCM)	2	4	Cu / Al	3954 4060
800 ... 1200 ⁽¹⁾	2x 2x(#2 - 600MCM)	2	6	Cu / Al	3954 3120
800 ... 1200 ⁽¹⁾	2x 2x(#2 - 600MCM)	2	8	Cu / Al	3954 4120



ul_032_a

(1) To be used to connect 4 wires on one terminal. In such a case, 2 lugs are placed side-by-side on one terminal. Please refer to dimensions diagram

Characteristics

Characteristics according to UL 1008

General use rating (A)	100 A	200 A	260 A	400 A	600 A	800 A	1200 A
Frame size	B4		B5		B6	B7	
Operation voltage 2 P - 3/4 P	240/600	240/600	240/600	240/600	-/600	-/600	-/600
Short circuit rating at 600 VAC with fuses (kA)							
Short circuit rating at 600 VAC (kA)	100	100	65	65	100	100	100
Type of fuse	J	J	J	J	L	L	L
Max fuse rating (A)	200	400	600	600	800	1000	1600
Short circuit rating at 600 VAC with "Specific Circuit Breaker" (kA)							
Square D JJ breaker 250 A - 2 P 240 VAC - 3/4 P 480 VAC	65	65	-	-	-	-	-
Schneider Electric NSX-F 160 A - 3/4 P 480 VAC	35	-	-	-	-	-	-
Short circuit rating at 600 VAC with "Any Breaker" (kA)							
Short circuit rating (kA)	10	10	14	14	35	35	35
Short circuit capacity (ms)	25	25	50	50	50	50	50
Rated operational current							
240 VAC "Total System" (A)	100	200	260	400	400	700	700
240 VAC resistive load (A)	100	200	260	400	600	800	1200
480 VAC "Total System" (A)	100	100	260	400	350	600	600
480 VAC resistive load (A)	100	200	260	400	600	800	1200
600 VAC "Total System" (A)	100	100	200	200	-	-	-
600 VAC resistive load (A)	100	200	260	400	600	800	1200
Mechanical endurance							
Endurance (number of operating cycles)	6050	6050	6050	4050	3050	3050	3050
Connection terminals							
Min. connection section / AWG	#6	#6	#4 / 2 X 1 / 0	#4 / 2 X 1 / 0	2 x #2	2 x #2	4 x #2
Max. connection section / AWG	300MCM	300MCM	600MCM / 2 X 250MCM	600MCM / 2 X 250MCM	2x 600MCM	2x 600MCM	4 x 600MCM

Characteristics according to UL 98 and CSA-C22.2 No. 4

General use rating at 600 VAC and 250 VDC (A)	Specific reference upon request				600 A	800 A	1200 A
Frame size					B6	B7	
Short-circuit rating at 600 VAC (kA)	-	-	-	-	200	100	100
Type of fuse	-	-	-	-	J	L	L
Max. fuse rating (A)	-	-	-	-	600	800	1200
Max. motor, hp / FLA 3 ph motor max.							
220-240 VAC	-	-	-	-	200 / 480	-	-
440-480 VAC	-	-	-	-	400 / 477	-	-
600 VAC	-	-	-	-	500 / 472	-	-
Mechanical characteristics							
Endurance (number of operating cycles)	-	-	-	-	5000	3500	2500
Operating torque (lbs.in/Nm)	-	-	-	-	327.5/37	442.5/50	442.5/50
Auxiliary contacts							
Electrical characteristics	A300	A300	A300	A300	A300	A300	A300

Mounting orientation

100 to 400 A / B4 - B5

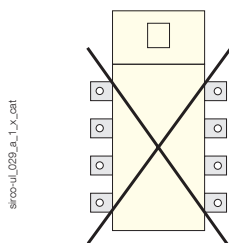

600 to 1200 A / B6 - B7

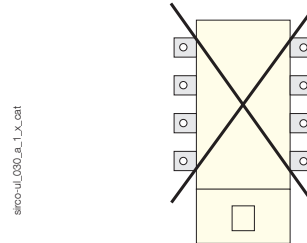

SIRCOVER UL 98/1008

Manually operated transfer switching equipment
from 100 to 1200 A

Dimensions (in/mm)

100 to 200 A / B4

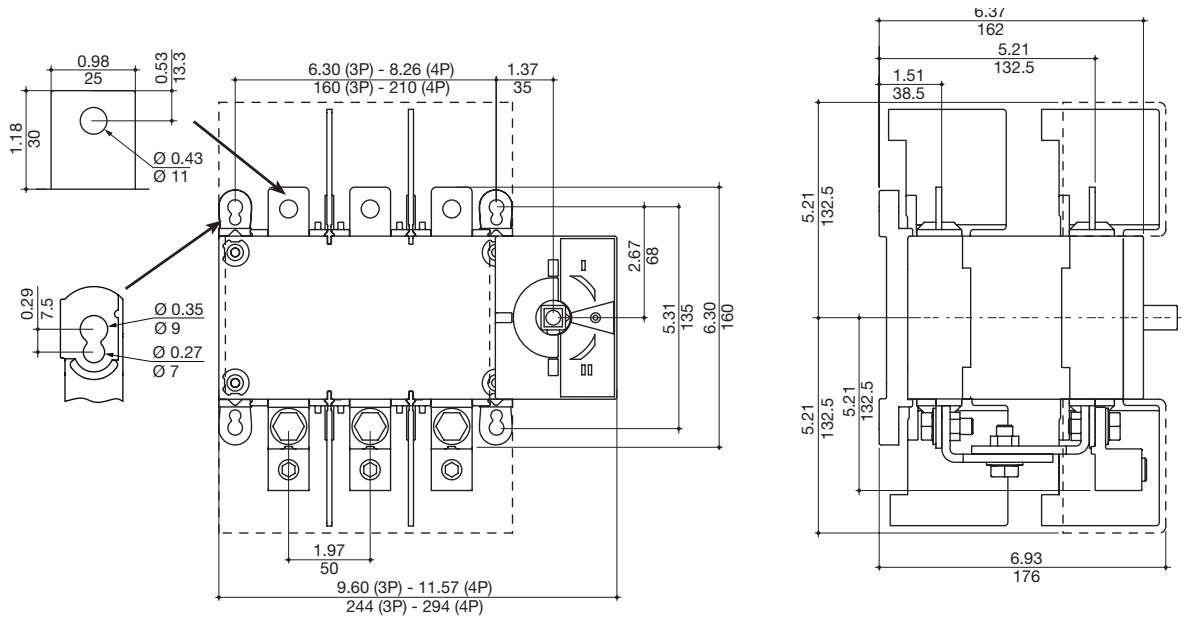

srn-ul_015_d1_x_cat

Minimum enclosure dimensions

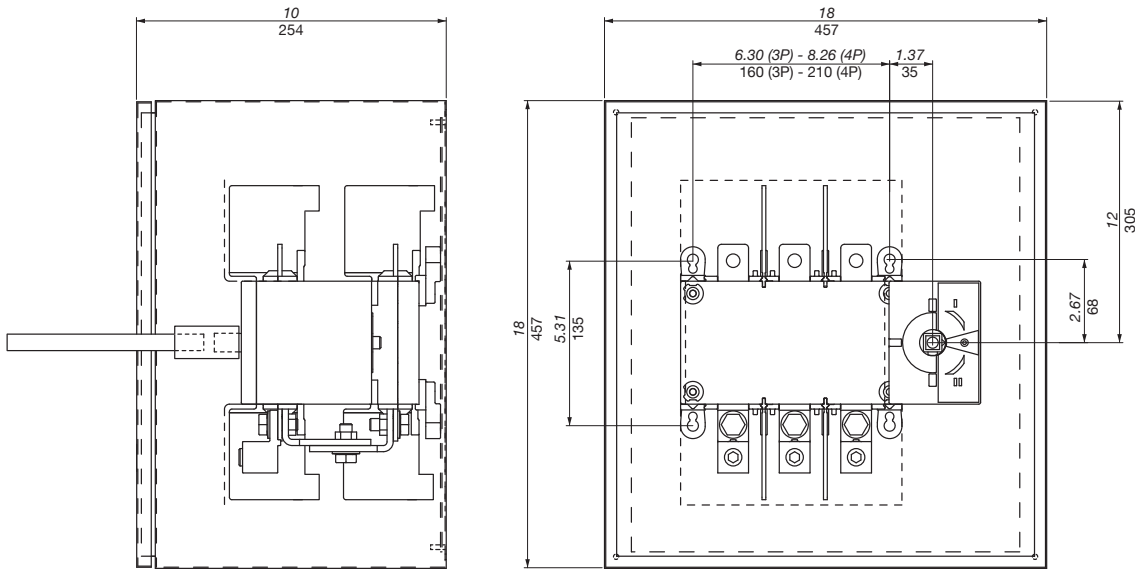

luser-ul_020_a_LX_cat

260 to 400 A / B5

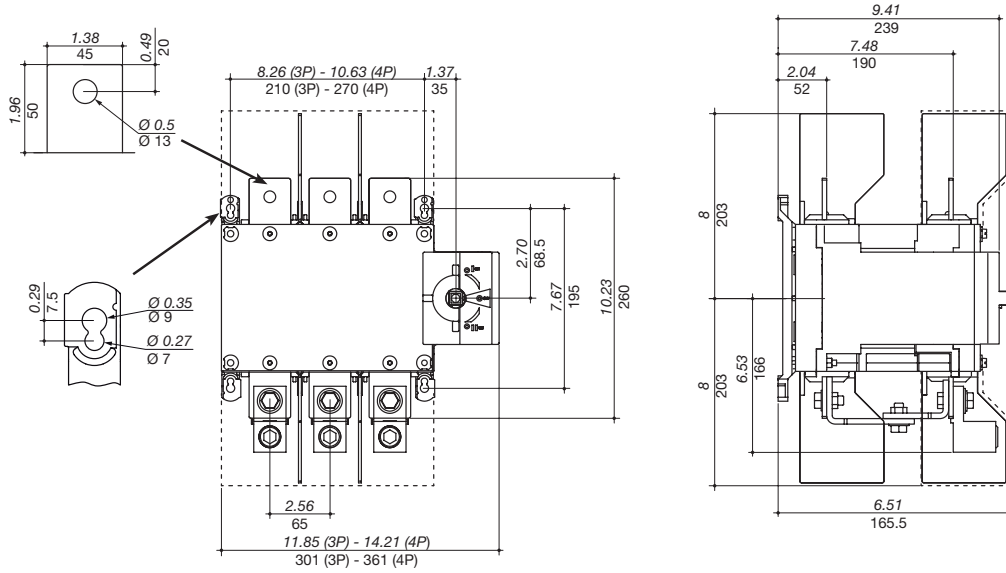

sw-ul016_b_1_x_cat

Minimum enclosure dimensions

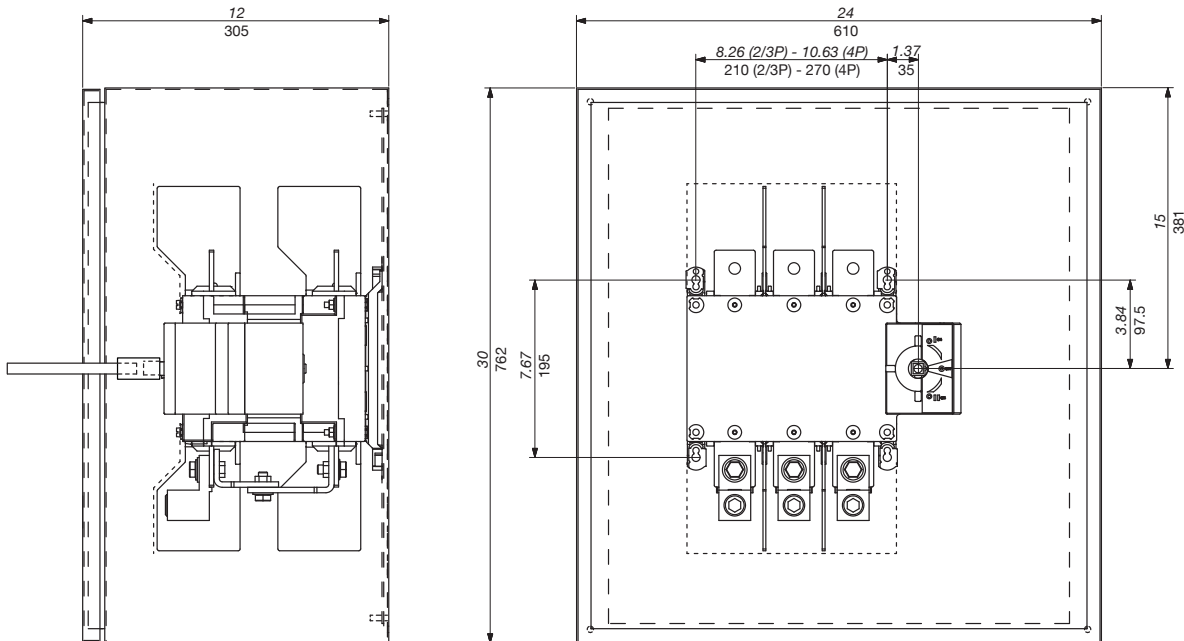

tu098-ul_021_a_1_x_cat_01

SIRCOVER UL 98/1008

Manually operated transfer switching equipment
from 100 to 1200 A

Dimensions (in/mm) (continued)

600 A / B6

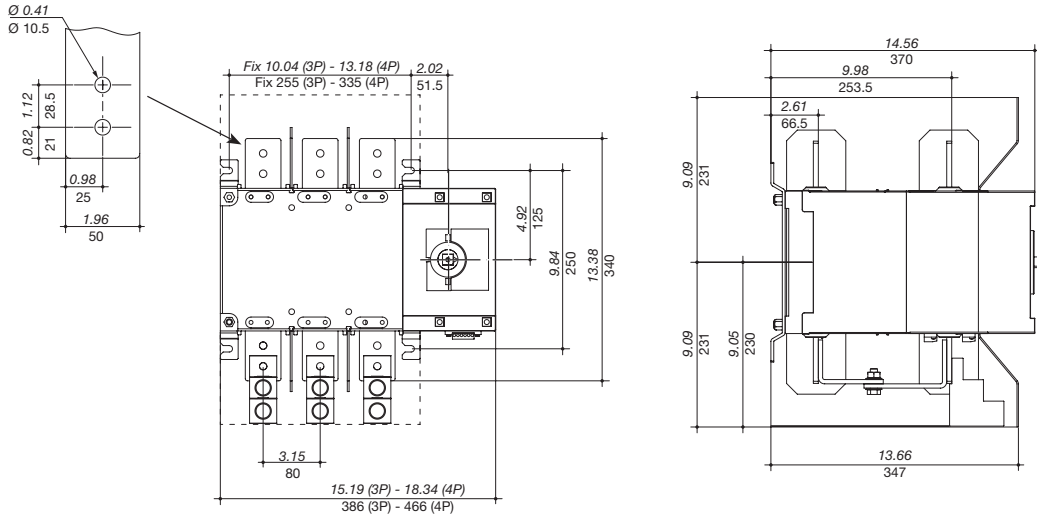

svr-ul_003_b_1_x_cat

Minimum enclosure dimensions

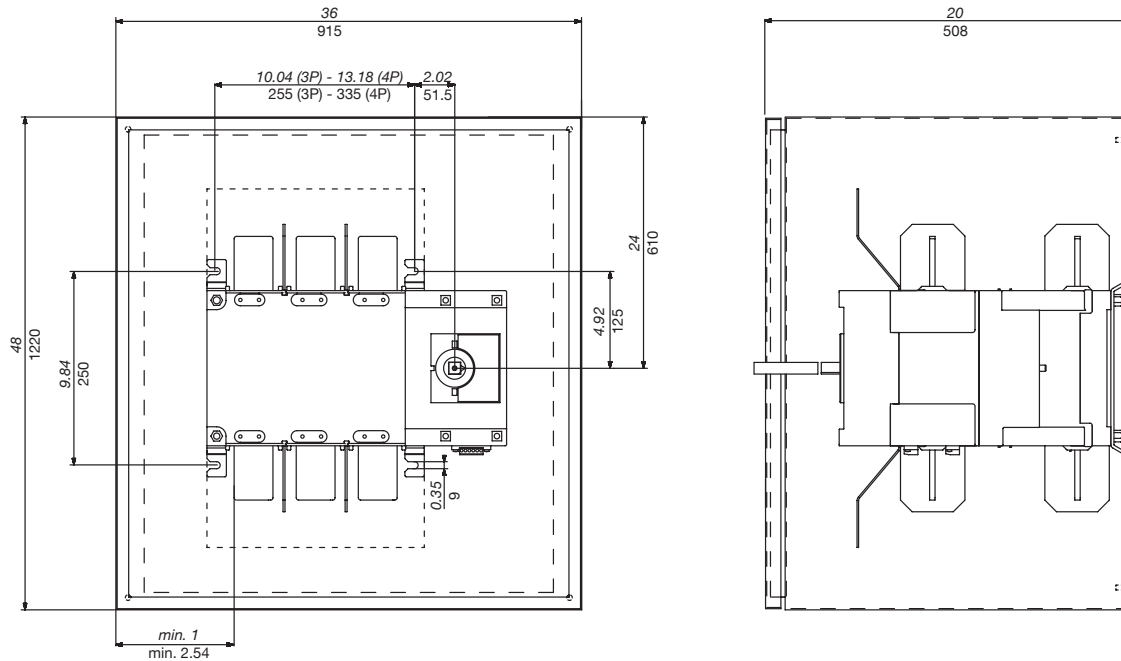

tuavr-ul_002_a_1_x_cat.all

800 to 1200 A / B7

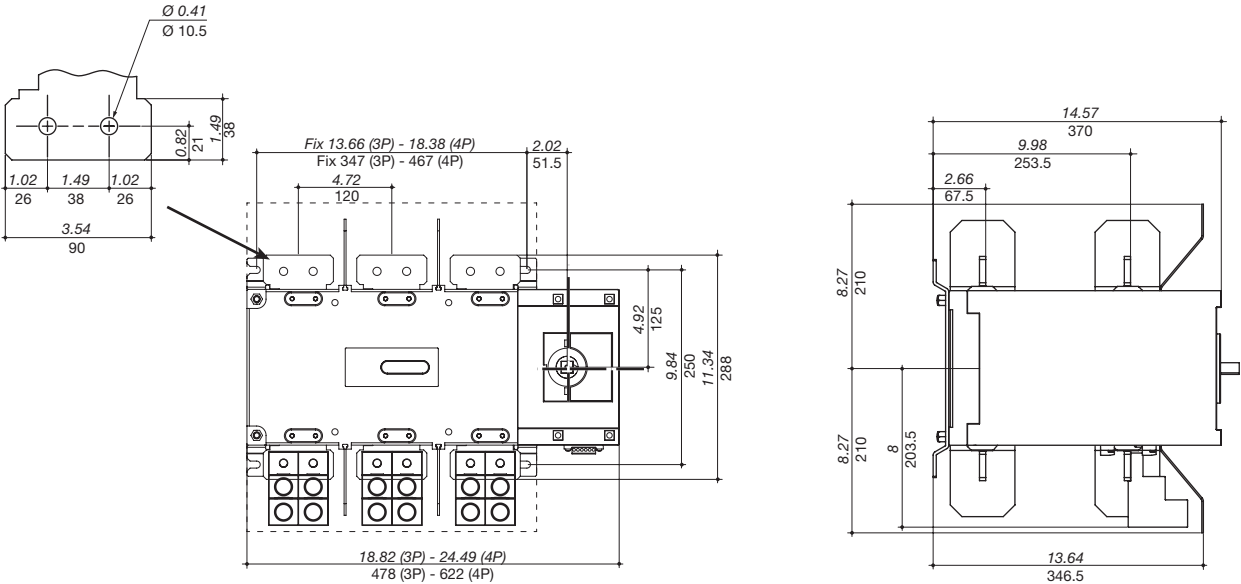

snr-ul_004_d_1_x_catt

Minimum enclosure dimensions

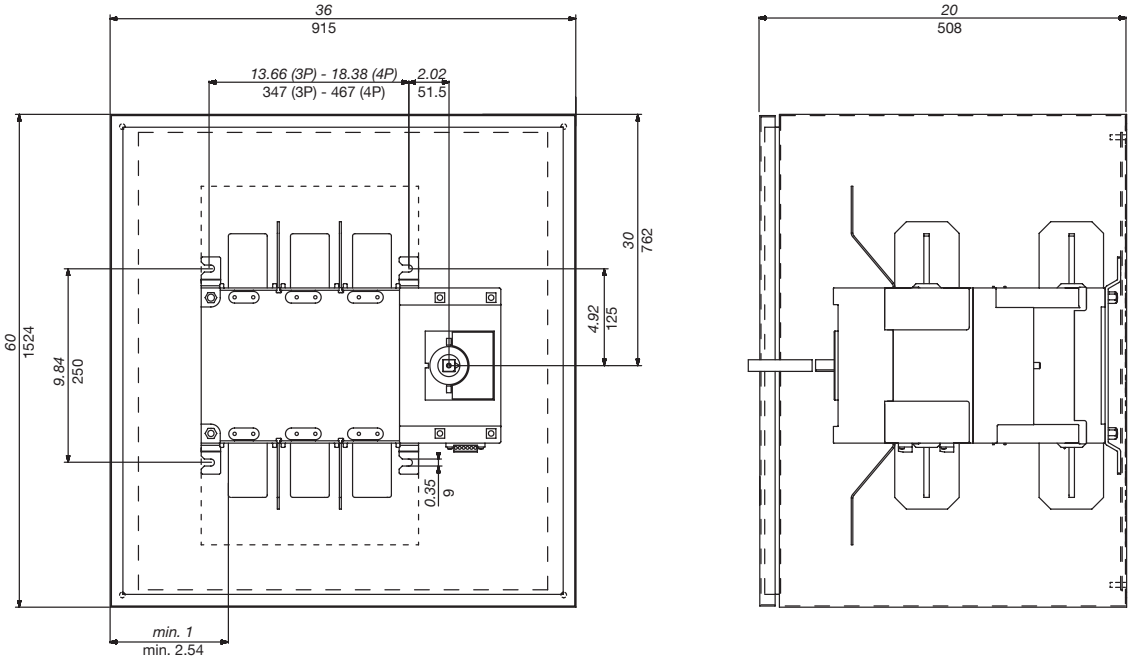

base-ul_023_a_1_x_catt

SIRCOVER UL 98/1008

Manually operated transfer switching equipment
from 100 to 1200 A

Terminal lugs (in/mm)

100 and 200 A / B4

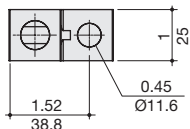

260 and 400 A / B5

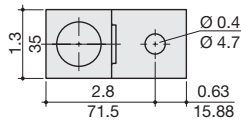

600 to 1200 A / B6 - B7

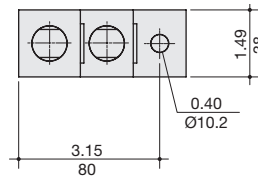

seco_115_b_1_us_cat

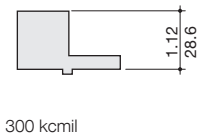

300 kcmil

seco_110_a_1_us_cat



600 kcmil

seco_115_b_1_us_cat

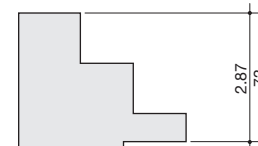

2 x 600 kcmil

External handle dimensions (in/mm)

100 to 400 A / B4 - B5

Handle type

Front operation

Direction of operation

Door drilling

S2 type

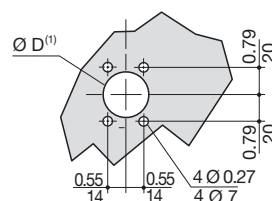
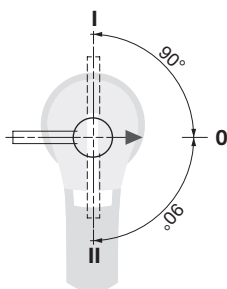
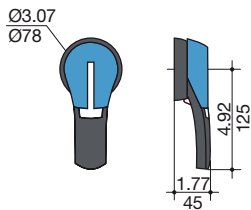

page_067_a_1_us_cat

260 and 600 A / B5 - B6

Handle type

Front operation

Direction of operation

Door drilling

S3 type

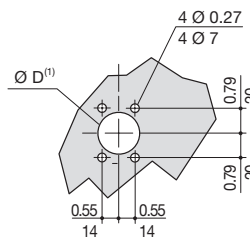
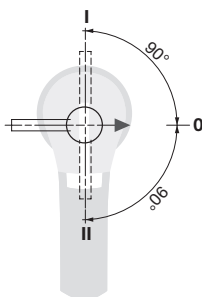
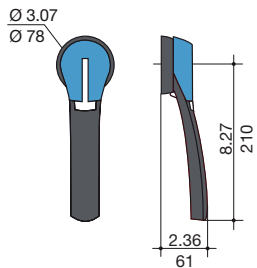

page_064_a_1_fr_cat

External handle dimensions (in/mm) (continued)

800 to 1200 A / B7

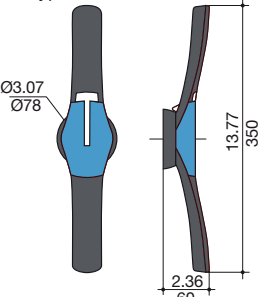
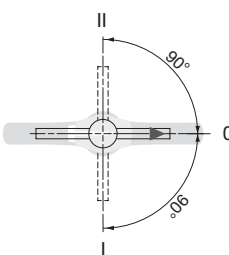
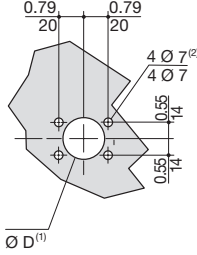
Handle type	Front operation Direction of operation	Door drilling
<p>S4 type</p> 		

(1) Ø31 to Ø37: rear screw mounting
 Ø37: front clip mounting

pogn_065_a_1_gb_cat

ATyS UL 1008

Non-automatic Transfer Switching Equipment
from 100 to 1200 A



Function

ATyS non-automatic transfer switches are designed for use in total system optional standby applications for the safe transfer between a normal and an alternate power source.

The changeover is done in open transition and with minimum supply interruption during transfer ensuring full compliance with UL 1008. The ATyS is a full on-load disconnecter where the main components are based on proven technology also meeting requirements in UL 98 and IEC 60947-3 standards.

Advantages

Robust and Reliable design

ATyS is a remotely operated transfer switch tested in full compliance with UL 1008. The design integrates a failsafe mechanical interlock to ensure that the main source is never inadvertently connected to the alternate. The stable position design ensures that the switch is unaffected by vibration or network voltage perturbation. The ATyS also includes a removable handle for on load manual operation. This is extremely safe and easy to use. The ATyS also includes a fully rated switched neutral pole.

Maintenance free

The self-cleaning contacts of the ATyS allow the power section to be maintenance free. For safe downstream maintenance the ATyS includes a facility for isolation and padlocking in the zero position.

In the unlikely event of a motorization failure, the ATyS is designed in a way that the motorization can be replaced easily and very quickly. Furthermore, the ATyS remains manually operational with or without the motorization in place.

Compatible with virtually any ATSE controller

The ATyS is directly compatible with virtually any transfer switching control solution that provides volt free contacts. This allows the ATyS to be combined with most ATS controller available on the market and then used in automatic transfer switch applications.

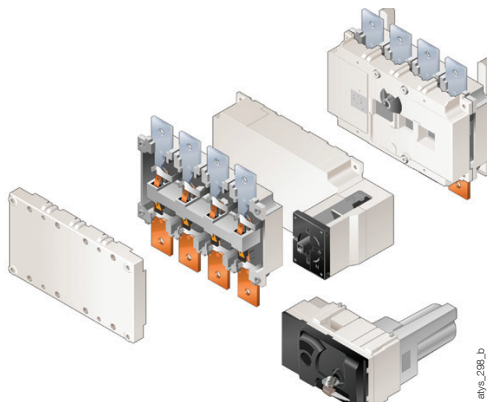

The solution for

- > Standby power builders
- > OEM/Machine Builders
- > Industrial Control Panels Manufacturers (UL 508A)
- > Switchboard Manufacturers (UL 891)
- > Distributors



Strong points

- > Robust and reliable design
- > Compatible with virtually any ATS controller
- > On-load manual operation
- > Maintenance free

Conformity to standards

- > UL 1008 guide WPYV File 317092
- > IEC 60947-6-1



Your choice of ATS controls

- > Socomec's ATyS C66 or your preferred brand of ATS controller, genset/AMF controller or power/building management system, may easily be paired with the ATyS to provide a complete automatic transfer switch that perfectly suits your needs.

Typical applications

The ATyS UL 1008 range provides safe transfer for mains/mains, mains/genset and genset/genset applications.

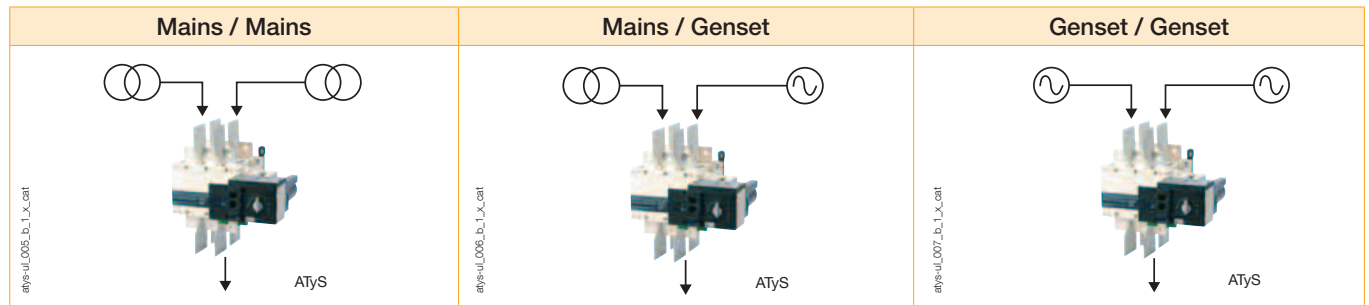



Part of a globally recognized range

The ATyS UL 1008 is part of a large family of products including a complete range of remotely operated and fully automatic transfer switches that comply with IEC and GB standards.

The ATyS range is a world renowned product family trusted by some of the largest manufacturers in the genset industry.

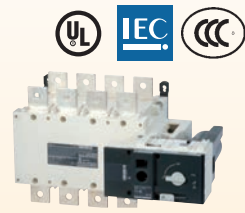
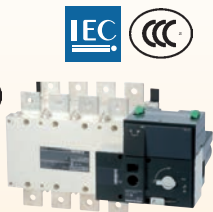
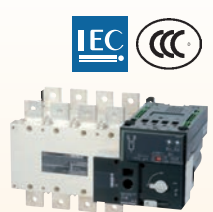
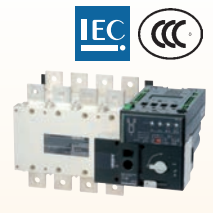
The key to success has been through reliable power availability provided by products that are safe and easy to use.

				
<p>ATyS r</p>	<p>ATyS d Remote Transfer Switching (RTS)</p>	<p>ATyS t Automatic Transfer Switching (ATS)</p>	<p>ATyS g Automatic Transfer Switching (ATS)</p>	<p>ATyS p Automatic Transfer Switching (ATS)</p>
<p>Remote Transfer Switch</p>	<p>Dual power supply</p>	<p>Automatic controller to manage mains/mains applications</p>	<p>Automatic controller to manage mains/genset applications</p>	<p>Functions for energy management Communication options</p>

Please don't hesitate to contact SOCOMEC with any questions regarding the IEC ATyS range of products above rated from 125 to 3200 A.

ATyS UL 1008

Non-automatic Transfer Switching Equipment

from 100 to 1200 A

References

ATYS UL 1008

Rating (A)	Frame size	No. of poles	ATyS	Bridging bars	Terminal screens	Auxiliary contact	Lug kits
100 A	B4	2 P	9723 2010	2 P 4159 2021 3 P	2/3 P 4158 3021 4 P	NO/NC 4159 0021	2 P
		3 P	9723 3010				3 P
		4 P	9723 4010				3 P
200 A		2 P	9723 2020	4 P	3954 3020		
		3 P	9723 3020	4 P	3954 4020		
		4 P	9723 4020	4 P	3954 4020		
260 A	B5	2 P	9723 2026	2 P 4159 2041 3 P	2/3 P 4158 3041 4 P	Low level 4159 0022	2 P
		3 P	9723 3026				3 P
		4 P	9723 4026				3 P
400 A		2 P	9723 2040	4 P	3954 3040		
		3 P	9723 3040	4 P	3954 4040		
		4 P	9723 4040	4 P	3954 4040		
600 A	B6	3 P	9723 3060	4159 3063	1609 3063		3954 3060
		4 P	9723 4060	4159 4063	1609 4063		3954 4060
800 A	B7	3 P	9723 3080	3 P 4159 3080 4 P	3 P 1609 3080 4 P	Contact NO/NC as standard	3 P
		4 P	9723 4080				3 P
1200 A		3 P	9723 3120	4 P	3954 3120		
		4 P	9723 4120	4 P	3954 4120		

Common accessories - more available on next pages.

Accessories

Terminal screens

Rating (A)	No. of poles	Reference
100 ... 200	2/3 P	4158 3021
100 ... 200	4 P	4158 4021
260 ... 400	2/3 P	4158 3041
260 ... 400	4 P	4158 4041
600	3 P	1609 3063
600	4 P	1609 4063
800 ... 1200	3 P	1609 3080
800 ... 1200	4 P	1609 4080

Use

Each part number includes top and bottom protection against direct contact with terminals or connecting parts.



access_207_a_2_catt

Bridging bars

Rating (A)	No. of poles	Reference
100 ... 200	2 P	4159 2021
100 ... 200	3 P	4159 3021
100 ... 200	4 P	4159 4021
260 ... 400	2 P	4159 2041
260 ... 400	3 P	4159 3041
260 ... 400	4 P	4159 4041
600	3 P	4159 3063
600	4 P	4159 4063
800 ... 1200	3 P	4159 3080
800 ... 1200	4 P	4159 4080

Use

For bridging power terminals on the top or bottom side of the switch. When ordering one reference is required per switch. Please check number of poles needed.



access_205_a_2_catt

Auxiliary contacts

Use

Pre-break and signalling of positions I and II: each reference provides 1 NO/NC auxiliary contact for positions I and II. ATyS are supplied with 1 NO auxiliary contact for all three positions as standard.

Rating (A)	Contact (s)	Reference
100 ... 400	NO/NC on position 1 and 2	4159 0021
100 ... 400	Low level NO/NC on position 1 and 2	4159 0022
600 ... 1200	NO/NC on position 1 and 2	as standard

A maximum of 2 Aux contacts per position may be added.



access_005_a_1_catt



access_005_a_1_catt

Terminal lugs

Use

Connection of bare copper cables onto the terminals (without lugs).

Rating (A)	Wires range	No wires per lug	Lugs per kit	Wires	Reference
100 ... 200	6 - 300MCM	1	2	Cu / Al	3954 2020
100 ... 200	6 - 300MCM	1	3	Cu / Al	3954 3020
100 ... 200	6 - 300MCM	1	4	Cu / Al	3954 4020
260 ... 400	4 - 600MCM	1	2	Cu / Al	3954 2040
260 ... 400	4 - 600MCM	1	3	Cu / Al	3954 3040
260 ... 400	4 - 600MCM	1	4	Cu / Al	3954 4040
600	2x (#2 - 600MCM)	2	3	Cu / Al	3954 3060
600	2x (#2 - 600MCM)	2	4	Cu / Al	3954 4060
800 ... 1200 ⁽¹⁾	2x 2x(#2 - 600MCM)	2	6	Cu / Al	3954 3120
800 ... 1200 ⁽¹⁾	2x 2x(#2 - 600MCM)	2	8	Cu / Al	3954 4120

(1) To be used to connect 4 wires on one terminal. In such a case, 2 lugs are placed side-by-side on one terminal. Please refer to dimensions diagram



ul_002_a

ATyS UL 1008

Non-automatic Transfer Switching Equipment

from 100 to 1200 A

Spares

Motorization module

Rating (A)	No. of poles	Frame size	Used for ATyS reference	Motorization module References
100	2 / 3 / 4 P	B4	9723 2010 - 9723 3010 - 9723 4010	9709 5010
200	2 / 3 / 4 P		9723 2020 - 9723 3020 - 9723 4020	9709 5020
260	2 / 3 / 4 P		9723 2026 - 9723 3026 - 9723 4026	9709 5026
400	2 / 3 / 4 P	B5	9723 2040 - 9723 3040 - 9723 4040	9709 5040
600	3 / 4 P		9723 3060 - 9723 4060	9709 5060
800	3 / 4 P	B7	9723 3080 - 9723 4080	9709 5080
1200	3 / 4 P		9723 3120 - 9723 4120	9709 5120



atys_b71.eps

Terminal lugs (in/mm)

100 and 200 A / B4

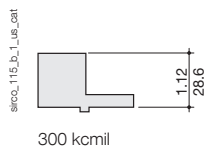
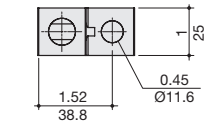

260 and 400 A / B5

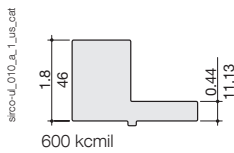
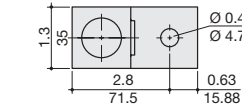

600 to 1200 A / B6 - B7

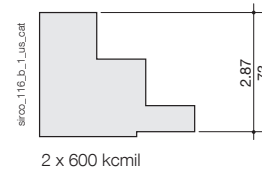
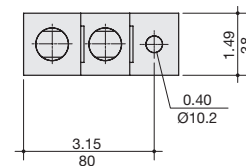

Mounting orientation

100 to 400 A / B4 - B5

Recommended	OK	Not Allowed	OK

600 to 1200 A / B6 - B7

Recommended	Not Allowed	OK	OK

Characteristics

Characteristics according to UL 1008 (Optional standby)

General use rating (A)	100 A	200 A	260 A	400 A	600 A	800 A	1200 A
Frame size	B4		B5		B6	B7	
Operation voltage 2 P - 3/4 P	240/600	240/600	240/600	240/600	-/600	-/600	-/600
Short circuit rating at 600 VAC with fuses (kA)							
Short circuit rating at 600 VAC (kA)	100	100	65	65	100	100	100
Type of fuse	J	J	J	J	L	L	L
Short circuit rating at 600 VAC with "Specific Circuit Breaker" (kA)							
Square D JJ breaker 250 A - 2 P 240 VAC - 3/4 P 480 VAC	65	65	-	-	-	-	-
Schneider Electric NSX-F 160 A - 3/4 P 480 VAC	35	-	-	-	-	-	-
Short circuit rating at 600 VAC with "Any Breaker" (kA)							
Short circuit rating (kA)	10	10	14	14	35	35	35
Short circuit capacity (ms)	25	25	50	50	50	50	50
Rated operational current							
240 VAC "Total System" (A)	100	200	260	400	400	700	700
240 VAC resistive load (A)	100	200	260	400	600	800	1200
480 VAC "Total System" (A)	100	100	260	400	350	600	600
480 VAC resistive load (A)	100	200	260	400	600	800	1200
600 VAC "Total System" (A)	100	100	200	200	-	-	-
600 VAC resistive load (A)	100	200	260	400	600	800	1200
Mechanical endurance							
Endurance (number of operating cycles)	6050	6050	6050	4050	3050	3050	3050
Connection terminals							
Min. connection section / AWG	#6	#6	#4 / 2 X 1 / 0	#4 / 2 X 1 / 0	2 x #2	2 x #2	4 x #2
Max. connection section / AWG	300MCM	300MCM	600MCM / 2 X 250MCM	600MCM / 2 X 250MCM	2x 600MCM	2x 600MCM	4 x 600MCM
Power supply							
Supply voltage VAC 50/60 Hz	208-277 VAC ± 20%						
Switching time							
I to II or II to I (s)	1.3				3.2		
I to 0 or 0 to II (s)	0.85				1.8		
Duration of electrical blackout (s)	0.6				1.6		

Terminals and connections

Typical wiring for 277/480 VAC and 120/208 VAC networks

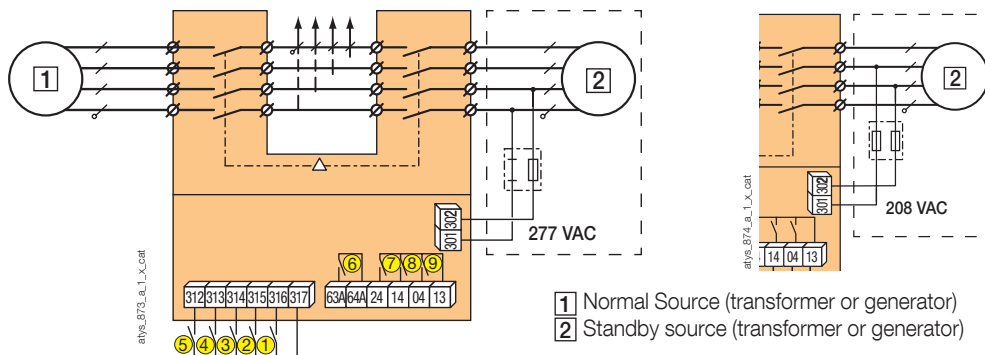

- 1: position 0 order input (contactor logic if closed)
- 2: position I order input
- 3: position II order input
- 4: position 0 priority order input
- 5: Input to enable or disable inputs 1 to 4

- 6: product availability relay, (watchdog)
- 7: auxiliary contact, closed when the switch is in position II
- 8: auxiliary contact, closed when the switch is in position I
- 9: auxiliary contact, closed when the switch is in position 0

ATyS UL 1008

Non-automatic Transfer Switching Equipment

from 100 to 1200 A

Dimensions (in/mm)

100 to 400 A / B4 - B5

Transfer switch dimensions

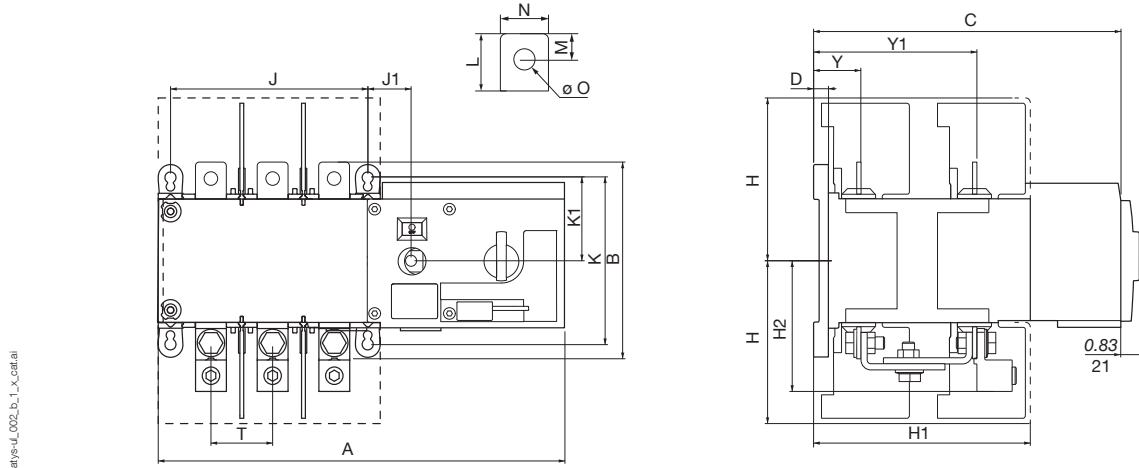

Rating (A)	Frame size	Reference	No. of poles	A		B		C		D		H		H1		H2		Y		Y1	
				in	mm	in	mm	in	mm	in	mm	in	mm	in	mm	in	mm	in	mm	in	mm
100 - 200	B4	9723 2010 - 9723 2020	2 P	12.91	328	6.30	160	9.60	244	0.41	10.5	5.08	129	6.93	176	4.21	107	1.51	38.5	5.21	132.5
		9723 3010 - 9723 3020	3 P																		
		9723 4010 - 9723 4020	4 P	14.88	378																
260 - 400	B5	9723 2026 - 9723 2040	2 P	14.84	377	10.23	260	12.62	320.5	0.41	10.5	8	203	6.51	165.5	6.53	166	2.04	52	7.48	190
		9723 3026 - 9723 3040	3 P																		
		9723 4026 - 9723 4040	4 P	17.20	437																

Rating (A)	Frame size	Reference	No. of poles	J		J1		K		K1		L		M		N		O		T	
				in	mm	in	mm	in	mm	in	mm	in	mm	in	mm	in	mm	in	mm	in	mm
100 - 200	B4	9723 2010 - 9723 2020	2 P	6.30	160	1.37	35	7.67	195	3.84	97.5	1.18	30	0.53	13.3	0.98	25	0.43	11	2	50
		9723 3010 - 9723 3020	3 P																		
		9723 4010 - 9723 4020	4 P	8.26	210																
260 - 400	B5	9723 2026 - 9723 2040	2 P	8.26	210	1.37	35	7.67	195	3.84	97.5	1.96	50	0.49	20	1.38	45	0.51	13	2.6	65
		9723 3026 - 9723 3040	3 P																		
		9723 4026 - 9723 4040	4 P	10.63	270																

100 to 400 A / B4 - B5

Minimum enclosure dimensions

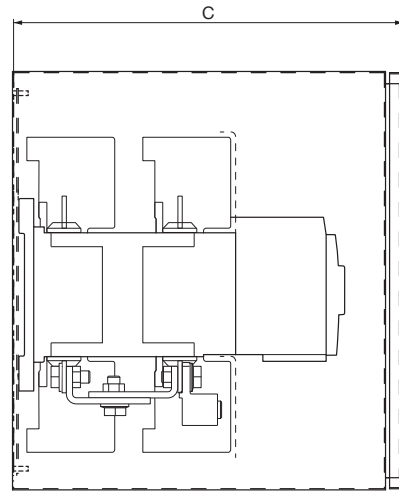
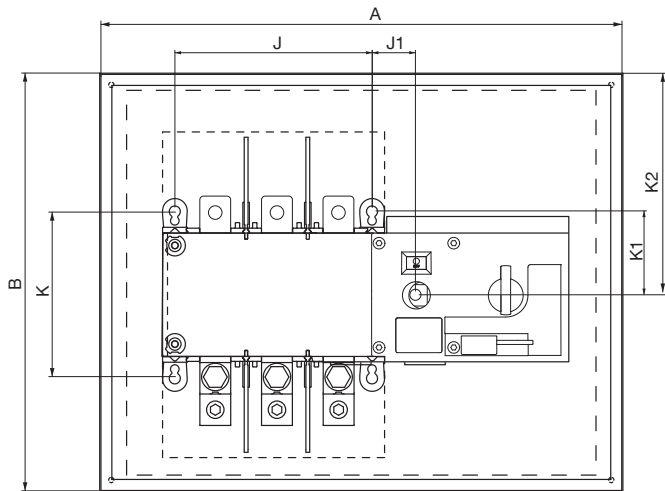

Door cut-out for front panel

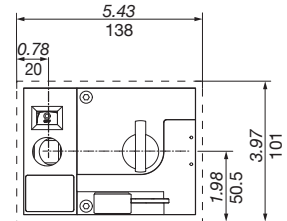

atyse-ul_008_b_1_x_cat1a

atyse-ul_017_a_1_x_cat1a

Rating (A)	Frame size	Reference	No. of poles	A		B		C		J		J1		K		K1		K2	
				in	mm	in	mm	in	mm	in	mm	in	mm	in	mm	in	mm	in	mm
100 - 200	B4	9723 2010 - 9723 2020	2 P	24	610	24	610	12	305	6.30	160	1.37	35	7.67	195	2.67	68	12	305
		9723 3010 - 9723 3020	3 P																
		9723 4010 - 9723 4020	4 P							8.26	210								
260 - 400	B5	9723 2026 - 9723 2040	2 P	32	813	32	813	16	406	8.26	210	1.37	35	7.67	195	3.84	97.5	15	381
		9723 3026 - 9723 3040	3 P																
		9723 4026 - 9723 4040	4 P							10.63	270								

Dimensions (in/mm) (continued)

600 to 1200 A / B6 - B7

Transfer switch dimensions

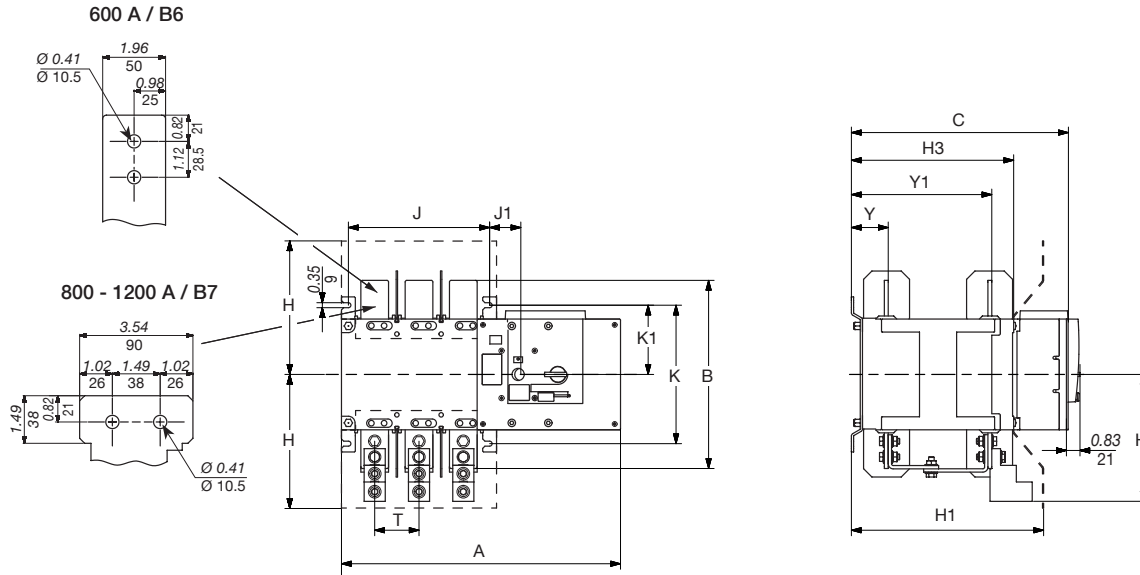

atys-ul_018_a_1_x_central

Rating (A)	Frame size	Reference	No. of poles	A		B		C		H		H1		H2		H3	
				in	mm	in	mm	in	mm	in	mm	in	mm	in	mm	in	mm
600	B6	9723 3060	3 P	19.8	504	13.38	340	15.4	392	9.09	231	13.7	347	9.05	230	11.5	293
		9723 4060	4 P	22.99	584												
800 - 1200	B7	9723 3080 - 9723 3120	3 P	23.5	596	11.34	288	15.4	392	8.30	211	13.7	347	8.03	204	11.5	293
		9723 4080 - 9723 4120	4 P	28.2	716												

Rating (A)	Frame size	Reference	No. of poles	J		J1		K		K1		T		Y		Y1	
				in	mm	in	mm	in	mm	in	mm	in	mm	in	mm	in	mm
600	B6	9723 3060	3 P	10	255	2.02	51.5	9.84	250	4.92	125	3.15	80	2.61	66.5	9.98	254
		9723 4060	4 P	13.2	335												
800 - 1200	B7	9723 3080 - 9723 3120	3 P	13.7	347	2.02	51.5	9.84	250	4.92	125	4.72	120	2.65	67.7	9.98	254
		9723 4080 - 9723 4120	4 P	18.4	467												

600 to 1200 A / B6 - B7

Minimum enclosure dimensions

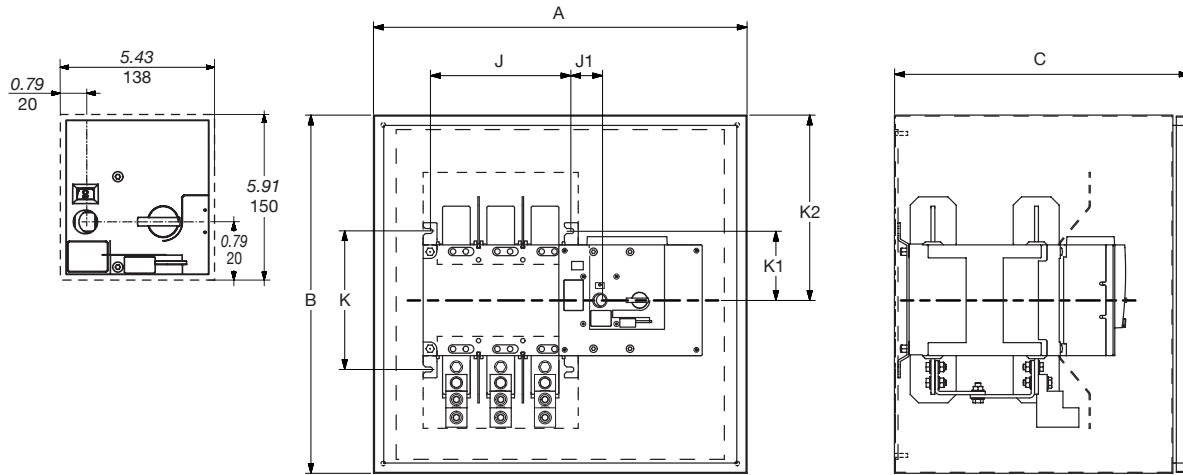

atys-ul_019_a-1_x_cat.ai

Rating (A)	Frame size	Reference	No. of poles	A		B		C		J		J1		K		K1		K2	
				in	mm	in	mm	in	mm	in	mm	in	mm	in	mm	in	mm	in	mm
600	B6	9723 3060	3 P	36	915	48	1220	20	508	10.04	255	2.02	51.5	9.84	250	4.92	125	24	610
		9723 4060	4 P	36	915	48	1220	20	508	12.18	355								
800 - 1200	B7	9723 3080 - 9723 3120	3 P	36	915	60	1524	20	508	13.66	347	2.02	51.5	9.84	250	4.92	125	30	762
		9723 4080 - 9723 4120	4 P	36	915	60	1524	20	508	18.38	467								

ATyS FT - ATyS DT

Automatic Transfer Switching Equipment
from 100 to 400 A

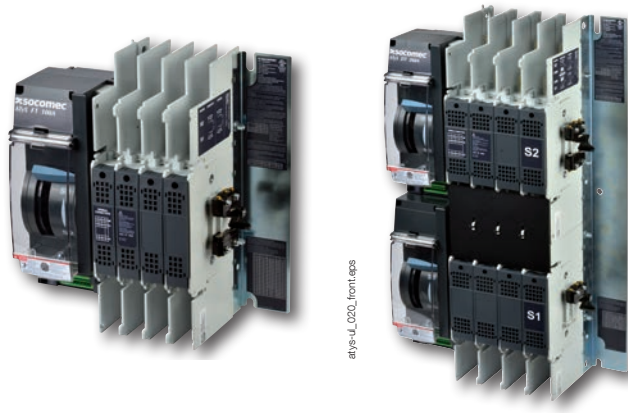

Function

ATyS FT and ATyS DT are fully automatic open transition transfer switches for use in total system emergency, legally required and standby applications for the safe transfer between a normal and an alternate power source.

ATyS FT is a fast transfer switch with no center off position and the ATyS DT is a delayed transfer switch with a center off position allowing full control of the time spent disconnected from both incoming sources.

Advantages

Robust, reliable and high performing

Rated for emergency systems and total system without derating, these switches also include high short-circuit rating with specific breakers or fuses up to 100 kA.

Safe manual handle

The ATyS FT and ATyS DT ensure the safety of your maintenance personnel due to patented safety features.

Access to the manual handle is prohibited by a transparent polycarbonate cover that requires a deliberate action to open. Once the cover is opened, the switch and the controller are both electrically inhibited which prevents any unexpected transfer during maintenance. The power switching characteristics when using the main manual handle are as reliable as when operated automatically ensuring safe transfers in all cases.

Intuitive use and simple installation

The ATyS FT and ATyS DT include the ATyS C66 controller, designed for simple and intuitive configuration.

Inspectable contacts

The ATyS FT and ATyS DT are specifically designed to reduce the time it takes to inspect power contacts due to the specific maintenance mode.

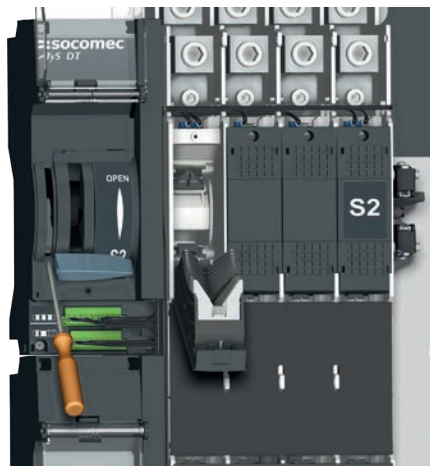

The solution for

- > Emergency systems
- > Legally required standby systems
- > Optional standby systems



Strong points

- > Robust, reliable and high performing
- > Safe manual handle
- > Intuitive use and simple installation
- > Inspectable contacts

Conformity to standards

- > UL 1008
CSA-C22.2
No.178.1-14
Guide WPWR
File E506172



Typical applications

The ATyS FT/DT range provides safe transfer for mains/mains or mains/genset in emergency, legally required and optional standby systems as described in the NEC® (NFPA 70).

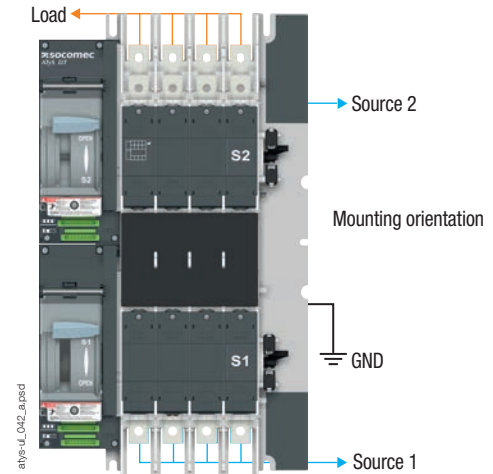
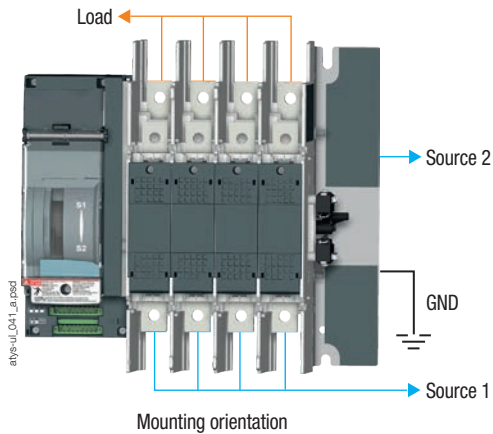

Additional Products

ATyS C66



The ATyS C66 controller is also available as a standalone product (certified to UL 61010) easily configurable for use with all transfer switching technologies (switches, contactors or circuit breakers). The ATyS C66 features intuitive menus, configurable I/O and is NEMA 3R/12 rated.

See the separate catalog pages for more details on the ATyS C66 controller.

ATyS UL 1008

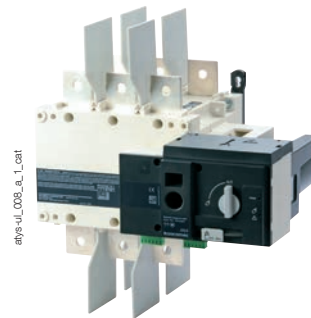

The ATyS UL 1008 is designed to meet the requirements of UL 1008 optional standby applications rated from 100 to 1200 A featuring a field replaceable motor and maintenance free contacts.

See the separate catalog pages for more details on the ATyS UL 1008.

ATyS FT - ATyS DT

Automatic Transfer Switching Equipment
from 100 to 400 A

References

ATyS FT: Fast transfer I - II switch & controller

The ATyS FT switches are comprised of a UL 1008 transfer switch, ATyS C66 controller (including a gasket to meet NEMA 3R/12, door mounting screws and back plate mounting feet), 2 NO/NC auxiliary contacts mounted on the switch, and a cable harness to connect the ATyS FT switch body to the C66 controller.

Rating (A)	Frame size	N° of poles ⁽¹⁾	ATyS FT Reference	ATyS FT spare switch Reference	ATyS FT Spare harness Reference	Terminal screens	Additional auxiliary contacts		
100	F1	2 P	96A0 2010	9600 2010	9696 4000	9698 2020	9699 0021		
		2 P+SN	96A1 2010	9601 2010		9698 3020			
		3 P	96A0 3010	9600 3010	9697 4001	9698 4020			
		3 P ⁽²⁾	9680 3010						
		3 P+SN	96A1 3010	9601 3010	9696 4000	9698 2020			
4 P		96A0 4010	9600 4010						
200		F1	2 P	96A0 2020	9600 2020	9696 4000		9698 3020	9699 0021
			2 P+SN	96A1 2020	9601 2020				
			3 P	96A0 3020	9600 3020	9697 4001		9698 4020	
			3 P ⁽²⁾	9680 3020					
	3 P+SN		96A1 3020	9601 3020	9696 4000	9698 2040			
4 P	96A0 4020		9600 4020						
260	F2		2 P	96A0 2026	9600 2026	9696 4000	9698 3040	9699 0021	
			2 P+SN	96A1 2026	9601 2026				
			3 P	96A0 3026	9600 3026	9697 4001	9698 4040		
			3 P ⁽²⁾	9680 3026					
		3 P+SN	96A1 3026	9601 3026	9696 4000	9698 2040			
4 P		96A0 4026	9600 4026						
400		F2	2 P	96A0 2040	9600 2040	9696 4000	9698 3040		9699 0021
			2 P+SN	96A1 2040	9601 2040				
			3 P	96A0 3040	9600 3040	9697 4001	9698 4040		
			3 P ⁽²⁾	9680 3040					
	3 P+SN		96A1 3040	9601 3040	9696 4000	9698 2040			
4 P	96A0 4040		9600 4040						

(1) Switches with "+SN" include a solid neutral pole, all other configurations include fully rated switched poles.

(2) Product references include specific harness for 480 V.a.c networks without neutral connector. Transformer is not included and must be purchased separately by contacting us.

ATyS DT: Delayed transition I - II switch with center off switch & controller

The ATyS DT switches are comprised of a UL 1008 transfer switch, ATyS C66 controller (including a gasket to meet NEMA 3R/12, door mounting screws and back plate mounting feet), 2 NO/NC auxiliary contacts mounted on the switch, and a cable harness to connect the ATyS DT switch body to the C66 controller.

Rating (A)	Frame size	N° of poles ⁽¹⁾	ATyS DT	ATyS DT spare switch	ATyS DT spare harness	Terminal screens	Additional auxiliary contacts
100	F1	3 P	98A0 3010	9800 3010	9896 4000	9698 3020	9699 0021
		3 P ⁽²⁾	9880 3010		9897 4000		
		3 P+SN	98A1 3010	9801 3010	9896 4000	9698 4020	
		4 P	98A0 4010	9800 4010			
200	F1	3 P	98A0 3020	9800 3020	9897 4000	9698 3020	
		3 P ⁽²⁾	9880 3020				
		3 P+SN	98A1 3020	9801 3020	9896 4000	9698 4020	
		4 P	98A0 4020	9800 4020			
260	F2	3 P	98A0 3026	9800 3026	9897 4000	9698 3040	
		3 P ⁽²⁾	9880 3026				
		3 P+SN	98A1 3026	9801 3026	9896 4000	9698 4040	
		4 P	98A0 4026	9800 4026			
400	F2	3 P	98A0 3040	9800 3040	9897 4000	9698 3040	
		3 P ⁽²⁾	9880 3040				
		3 P+SN	98A1 3040	9801 3040	9896 4000	9698 4040	
		4 P	98A0 4040	9800 4040			

(1) Switches with "+SN" include a solid neutral pole, all other configurations include fully rated switched poles.

(2) Product references include specific harness for 480 V.a.c networks without neutral connector. Transformer is not included and must be purchased separately by contacting us.

ATyS FT - ATyS DT

Automatic Transfer Switching Equipment
from 100 to 400 A

Accessories

Terminal screens

Use

Top and bottom terminal screens to protect from direct contact to the terminals. These protection screens can be locked and secured on the switch, are pre-cut for all compatible wire sizes and include holes for voltage and heat sensing.

Rating (A)	No. of poles	Reference ⁽¹⁾
100 ... 200 A	2 P	9698 2020
	3 P / 2 P + N	9698 3020
	4 P / 3 P + N	9698 4020
260 ... 400 A	2 P	9698 2040
	3 P / 2 P + N	9698 3040
	4 P / 3 P + N	9698 4040

(1) Top and bottom.



atyS-ul_022.eps

Additional auxiliary contact kit

Use

The ATyS FT and the ATyS DT ship with 2 NO/NC auxiliary contacts already mounted on the switch. If additional auxiliary contacts are needed this kit includes 2 additional auxiliary contacts as well as a polycarbonate protection cover to protect from direct contact on auxiliary contact terminals. These additional auxiliary contacts are installed on top of the existing auxiliary contacts.

Electrical characteristics		Reference
Rated current (125-480 VAC)	22 A	9699 0021
Rated current (125 VDC)	0.5 A	
Rated current (250 VDC)	0.25 A	
Rated horse power up to 250 VAC	½ HP	
Rated horse power up to 480 VAC	¼ HP	
Recommended wire section	10 AWG 4 mm ²	



atyS-ul_023.eps

Characteristics according to UL 1008 and CSA-C22.2 No. 178.1-14

100 to 400 A

General use rating (A)	100	200	260	400
Frame size	F1		F2	
Compatible voltage networks	240 V 2 wires, 208 V 3 wires, 120 V 2 wires, 120/240 V 3 wires, 120/208 V 4 wires, 277/480 4 wires, 480 V 3 wires			
Short circuit rating at 480 VAC with fuses (kA)				
Short circuit current (kA)	100	100	100	100
Fuse link	J	J	J	J
Fuse rating (A)	400	400	600	600
Short circuit rating three phase at 480 VAC with "specific breaker" (kA)				
Square D : DC , FI , HD , HG , HJ , HL 100 A	50	50	-	-
Square D : JD , JG , JJ , JL 250 A	50	50	-	-
Square D : JJ , JL , JR 250 A	-	-	100	100
Schneider Electric NSX 400 A	-	-	65	65
Siemens 3VA5 100 A	50	50	-	-
Siemens 3VA5 , 3VA6 150 A	50	50	-	-
Siemens 3VA5 , 3VA6 250 A	50	50	65	65
Eaton FCL , JGS , JGH , JGC 250 A	35	35	-	-
Eaton LGH 400 A	-	-	50	50
GE SFL 250 A	-	-	65	65
Short circuit rating single phase at 240 VAC with "specific breaker" (kA)				
Square D : DC , FI , HD , HG , HJ , HL 100 A	50	50	-	-
Square D : JD , JG , JJ , JL 250 A	50	50	-	-
Siemens 3VA5 , 3VA6 250 A	-	-	65	65
Eaton LGH 400 A	-	-	50	50
GE SFL 250 A	-	-	100	100
Rated operational current (A)				
Up to 480 VAC "Resistive load"	100	200	260	400
Up to 480 VAC "Total system"	100	200	260	400
Mechanical endurance				
Endurance (number of operating cycles)	6050			
Connection terminal				
Min. connection section (AWG)	#6, 14 AWG	#6	#4	#4
Max. connection section (AWG)	1/0	250 KCMIL	300 KCMIL	600KCMIL
Associated lugs	CMC LA300R , ILSCO D0957	CMC LA300R , ILSCO D2831	CMC LA630R, ILSCO D3096-22	
Power supply				
Switch Supply voltage (VAC)	194-304			
Controller supply voltage (VAC)	84-575			
Minimum Switching time⁽¹⁾ (ms)				
Contact transfer time Normal to Alternate ⁽²⁾	24	24	30	30
Contact transfer time Alternate to Normal ⁽²⁾	21	21	27	27
Total transfer time Normal to Alternate ⁽³⁾	100	100	100	100
Total transfer time Alternate to Normal ⁽³⁾	410	410	410	410

(1) All switching time measured offload, with 240 VAC networks may vary according to network voltage and load type.

(2) Time for which load is disconnected from both source 1 and source 2 with both sources available.

(3) Total time to transfer including detection of source failure and transfer times (all customer adjustable timers set to 0 and specific functions disabled).

ATyS FT - ATyS DT

Automatic Transfer Switching Equipment
from 100 to 400 A

Dimensions

ATyS FT : Fast transfer I – II switch & controller

Switch dimensions

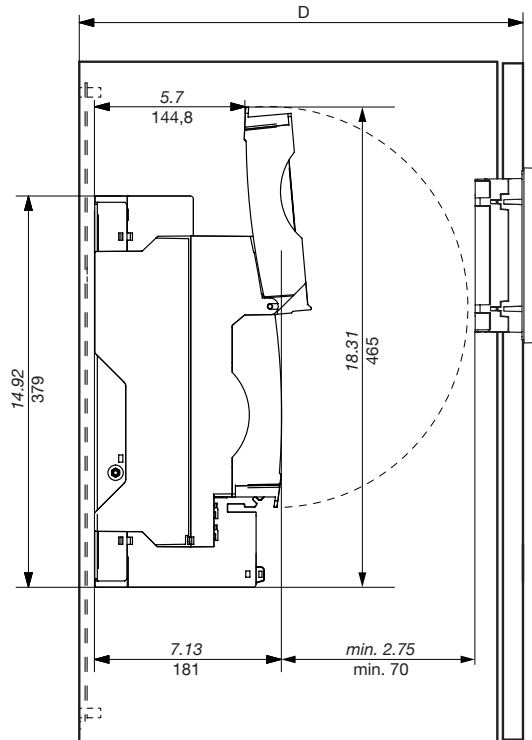
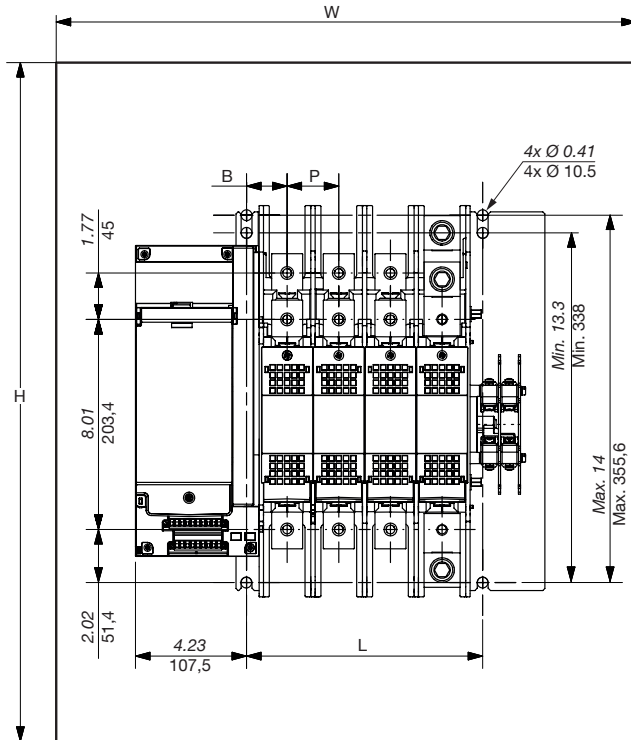

atys-ft_044_a_1_x_cat1a

Controller dimensions

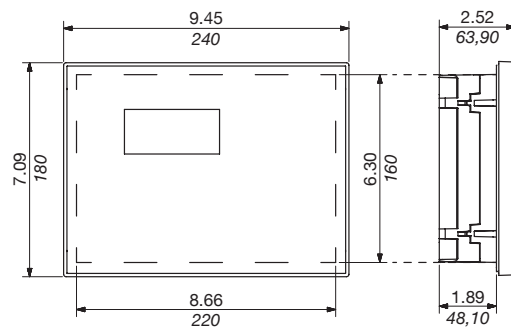
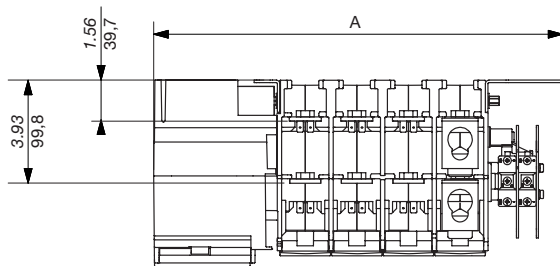

atys-ft_048_a_1_x_cat1a

Rating (A)	Nb Poles	A		B		L		P		H		W		D	
		in	mm	in	mm	in	mm	in	mm	in	mm	in	mm	in	mm
100-200A	2 P	10.47	266,30	1.25	31,80	3.85	98,70	1.38	35	20	508	16	406	12	305
	2 P + N / 3 P	11.85	301,30	1.25	31,80	5.49	133,70	1.38	35	20	508	16	406	12	305
	3 P + N / 4 P	13.24	336,30	1.25	31,80	6.60	168,70	1.38	35	20	508	16	406	12	305
260-400A	2 P	11.67	296,30	1.55	39,30	5	128,60	1.97	50	48	1220	24	610	12	305
	2 P + N / 3 P	13.63	346,30	1.55	39,30	7	178,60	1.97	50	48	1220	24	610	12	305
	3 P + N / 4 P	15.60	396,30	1.55	39,30	8.97	228,60	1.97	50	48	1220	24	610	12	305

ATyS DT : Delayed transition I – II switch with center off switch & controller

Switch dimensions

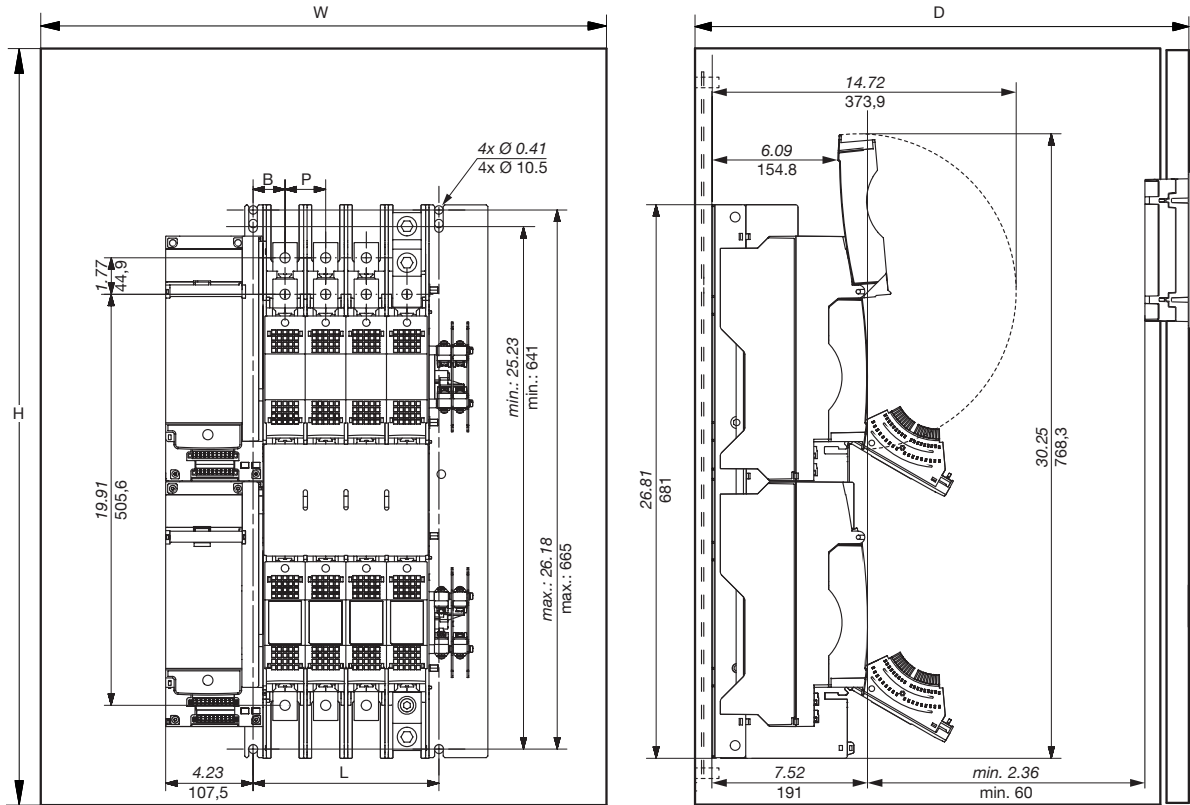

aty-s-ul_045_a_1_x_cat.ai

Controller dimensions

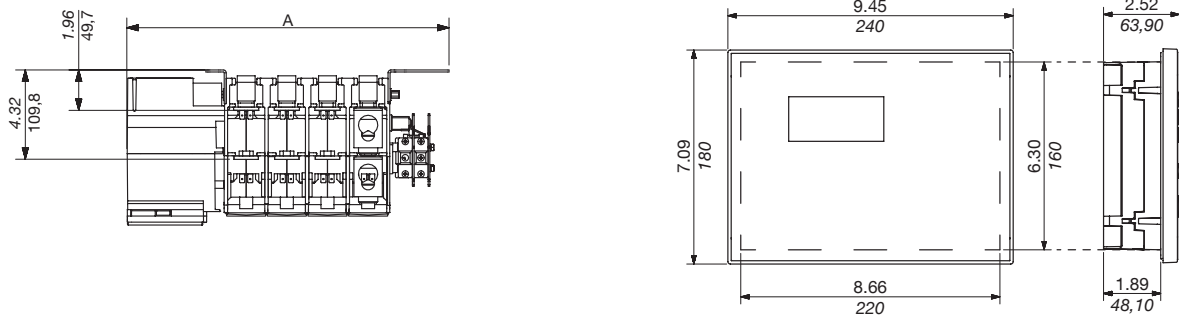

aty-s-ul_046_a_1_x_cat.ai

Rating (A)	Nb Poles	A		B		L		P		H		W		D	
		in	mm	in	mm	in	mm	in	mm	in	mm	in	mm	in	mm
100-200A	2 P + N / 3 P	11.85	301,30	1.25	31,80	5.49	133,70	1.38	35	36	915	16	407	12	305
	3 P + N / 4 P	13.24	336,30	1.25	31,80	6.60	168,70	1.38	35	36	915	16	407	12	305
260-400A	2 P + N / 3 P	13.63	346,30	1.55	39,30	7	178,60	1.97	50	60	1524	24	610	12	305
	3 P + N / 4 P	15.60	396,30	1.55	39,30	8.97	228,60	1.97	50	60	1524	24	610	12	305

ATyS C66

UL ATS Controller

for Open and Delayed Transition



ATyS C66

Function

ATyS C66 is an ATSE controller designed to control all types of emergency system, legally required and optional standby transfer switching equipment. The ATyS C66 is cULus 1008 listed with ATyS FT* and ATyS DT* power contactor switches as well as cURus 1008 and cULus 61010 listed for use with circuit breakers or contractors. ATyS C66 ensures automatic and manual transfer from one source to another with fully configurable timers and thresholds.

* ATyS FT Fast Transfer, ATyS DT Delayed Transfer.

Advantages

Fast commissioning

On initial power up, the ATyS C66's smart wizard will guide the operator through the commissioning process.

User customizable

Front panel LEDs, load shedding, engine exercisers and the elevator control signal are just some of the customizable features available on ATyS C66.

Intuitive operation

- The high-resolution LCD screen provides several dashboards enabling easy monitoring of all parameters, including power and energy consumption of the loads.
- The integrated energy backup provides transitional power to the product enabling status indication (switch position, timer status, fault notifications) and communication to remain active with no supply present.
- Quick and easy access to main functions through the front panel with direct key input.

General characteristics

- Self-powered from voltage sensing.
- Wide voltage range (88 - 576 VAC).
- 24 VDC aux power supply (for optional use).
- 6 x 8A programmable dry contact Form C outputs (SPDT) (2 latching relays).
- 6 x programmable inputs.
- DIN rail mountable I/O extension, up to 30 inputs and 18 outputs (accessory).
- Power & Energy metering with 1 or 5A current transformers.
- Up to 30 second energy backup.
- Smart wizard.
- 3000 Alarms and Events.
- Built-in engine exerciser with 4 independent programs.
- Associated Webserver software.
- In-phase transfer.
- Tiered access levels of password protection.
- UV tested.

References

Description	Reference
ATyS C66 controller	1600 0066
DIRIS Digiware IO-10 (4 input/2 output) DIN-rail extension	4829 0140
DIRIS Digiware M-70 communications gateway for Ethernet & Webserver	4829 0222
DIRIS Digiware D-70 communication gateway for Ethernet & Webserver and multi-product display	4829 0203
Current Transformers	Consult us
ATyS FT / ATyS DT and cable harnesses	Consult us

The solution for

- > Standby power builders
- > OEM/Machine builders
- > Industrial Control Panel Manufacturers (UL 508A)
- > Switchboard Manufacturers (UL 891)
- > Distributors



Strong points

- > Self-powered
- > Built-in advanced features
- > Intuitive menus & Dashboards
- > NEMA 3R/12

Conformity to standards

- > UL 61010
CSA-C22.2 No. 61010-1
Guide NRAQ
File E206136



- > UL 1008
CSA-C22.2 No. 178.1-14
File E506172



- > IEC 60947-6-1



Communication gateways



DIRIS Digiware M-70 & D-70

Front panel



1. Dashboard displays.
2. Navigation keypad.
3. Mimic LED indication.
4. Lamp test button / LED info.
5. AUTO mode select.
6. TEST button.
7. CONTROL mode select.
8. Position orders (only in CONTROL mode).
9. Customizable LED.
10. Hi-res LCD screen.

Dimensions (in/mm)

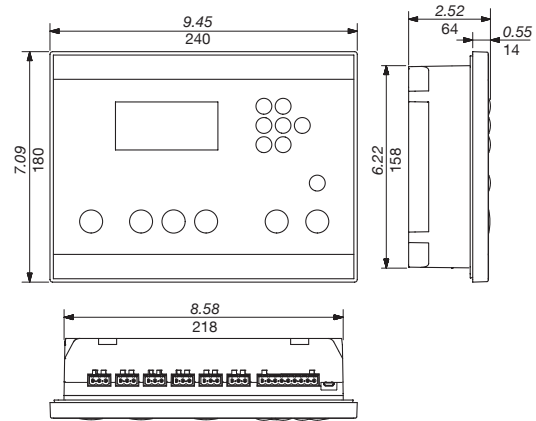

Characteristics

Electrical characteristics	
Operating AC limits	110 - 480 VAC ±20%
Optional DC supply	24 VDC
Frequency limits	45 - 65 Hz
Power consumption	< 10 W
Current transformers	1 or 5A
Measurement type	True RMS (TRMS)
Inputs	6 x fully programmable
Outputs	6 x form C, fully programmable
Output relays	8A general use
I/O Extension (IO10)	Up to 30 inputs and 18 outputs
Overvoltage category	CAT III
Impulse withstand	8/6 kV ⁽¹⁾

Mechanical characteristics	
Weight	2.38 lb / 1080 gr
Door cutout	8.66 x 6.3 in / 220 x 160 mm
Protection degree	NEMA 3R/12, IP65
Operating temperature	-22 ... +158 °F / -30 ... +70 °C
Communications	
Interface type	RS485. 2 to 3 half duplex wires
Protocol	MODBUS RTU
Baudrate	Programmable 1200 - 115200 bps
Digiware bus cable	RJ45 specific cable
Display	
Screen resolution	350 x 160 pixels
Event recorder	3000 events

(1) 8 kV tested between phases of a different source and 6 kV tested between phases of the same source.

Terminals

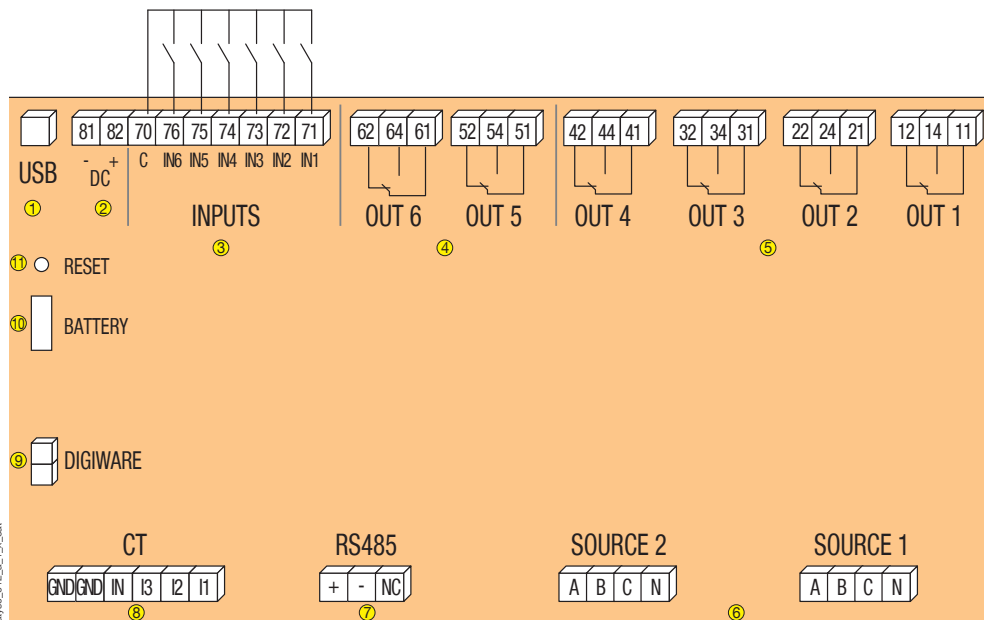

1. Configuration USB
2. 24 VDC aux power supply (for optional use)
3. 6 x inputs
4. 2 x latching relay outputs
5. 4 x relay outputs
6. Source sensing (110-480 ±20%)
7. RS485 communication
8. Current transformers (1 or 5A)
9. Digiware RJ45 connectors
10. Replaceable RTC battery
11. Hard reset button



Mounting, Cabling & Accessories

Accessories



Power Distribution
Blocks
p. 174

Busbars

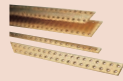

Rigid Copper Bars
p. 178



Flexible Copper Bars
p. 180



Insulated Copper Braids
p. 182



Edgewise Mounting
Busbar Supports
p. 184

Power Distribution Blocks

Distribution

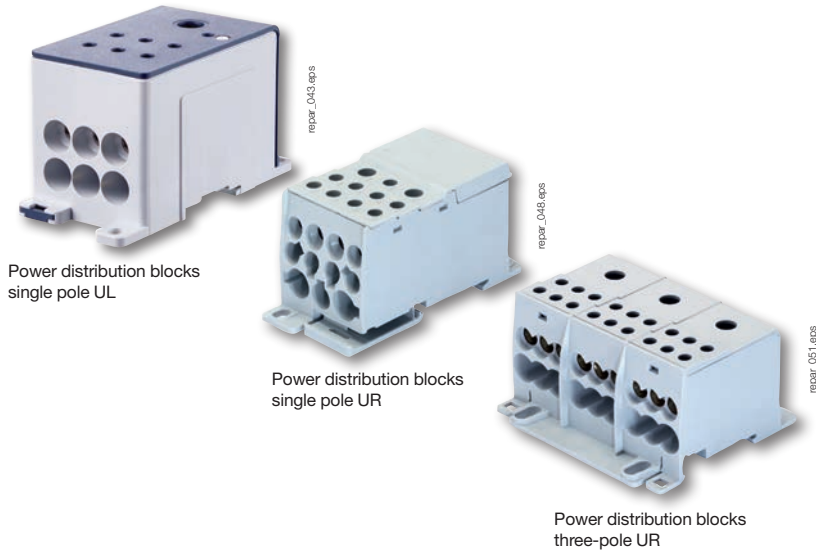

Function

SOCOMEK **Power Distribution Blocks** allow for easy connection to conductors to distribute power from one load into multiple smaller loads. They are installed downstream of a disconnect switch, transfer switch or circuit breaker.

Advantages

IP20 finger safe protection

- IP20 rated
- Finger-safe design provides touch safe protection from live parts

Wide range

The extent of the range makes it possible to find the distribution system adapted to its needs:

- 5 single pole power distribution blocks UL
- 4 single pole power distribution blocks UR
- 1 multipolar power distribution blocks UR

Easy integration

The compact design of the different distribution blocks allow for easier integration into the equipment.

Flexible wiring

Allows use of standard solid, stranded and fine wire strands with use of compression sleeve

UL & IEC range

The range of distribution blocks comply to both UL standards & IEC standards

Application

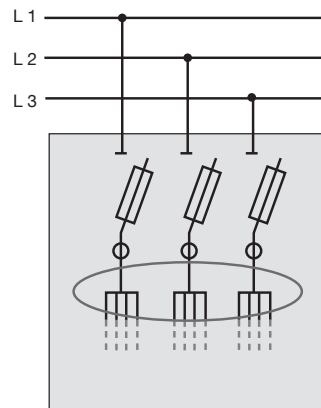

The solution for

- > Industrial Control Panels Manufacturers (UL 508A)
- > Switchboards Manufacturers (UL 891)
- > Distributors
- > OEM/Machine Builders
- > PV Combiner/Re-Combiner Box Manufacturers



Strong points

- > IP20 finger safe protection
- > Wide range
- > Easy integration
- > Flexible wiring
- > UL listed

Conformity to standards

- > UL 1953
Guide QPQS
File E500778
- > UL 1059
CSA-C22.2 No. 128
Guide XCFR
File E500524



- > IEC 61439-1
- > IEC 60947-7-1



Power Distribution Blocks UL 1953

General Characteristics



- Material: tin plated aluminum
- Suitable conductors: aluminum or copper
- IP20 finger-safe
- Adjustable Dial allows for Selection of L1–L2–L3 phase designation
- Simple and secure DIN rail locking clips allow for easy mounting on DIN rail
- Panel mounting
- Included connection clip allows to join multiple poles together
- Voltage Ratings: 1000 VAC/DC UL 1500VAC/VD IEC

References

Type	Rating (A)		References
	Cable Cu	Cable Al	
Type 1	85	65	54UL 1008
Type 2	115	90	54UL 1012
Type 3	175	135	54UL 1017
Type 4	255	205	54UL 1025
Type 5	380	310	54UL 1040

Dimensions (in/mm)

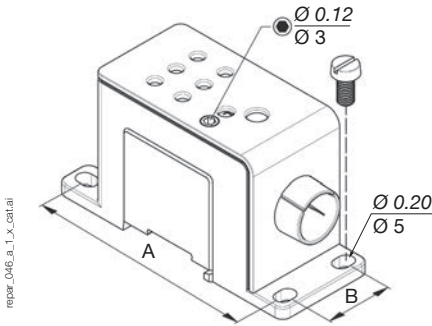

Type	Units	H x W x D	Mounting	
			A	B
Type 1	in	1.93 x 1.417 x 3.524	3.118	0.914
	mm	49 x 36 x 89.5	79.2	23.2
Type 2	in	1.93 x 1.417 x 3.524	3.118	0.914
	mm	49 x 36 x 89.5	79.2	23.2
Type 3	in	2.09 x 1.417 x 3.898	3.492	0.914
	mm	53 x 36 x 99	88.7	23.2
Type 4	in	2.39 x 2.126 x 4.488	4.063	1.622
	mm	60.7 x 54 x 114	103.7	41.2
Type 5	in	2.39 x 2.126 x 4.488	4.063	1.622
	mm	60.7 x 54 x 114	103.7	41.2

Connections & Electrical Characteristics

Type	For connection	Number of holes	Solid / stranded wired	Fine wire with sleeve	1953 Voltage Max.		Short circuit withstanding			Max. Fuse rating (A)		
					AC (V)	DC (V)	I _{cw} (kA)	I _{pk} (kA)	SCCR (kA)	Class RK5	Class RK1	Class J
Type 1	Line	1	3 - 14 AWG	3 - 14 AWG	1000	1000	3	35	100	200	250	
	Load	6	8 - 14 AWG	10 - 14 AWG								
Type 2	Line	1	1 - 14 AWG	2 - 14 AWG								
	Load	6	4 - 14 AWG	6 - 14 AWG								
Type 3	Line	1	2/0 - 14 AWG	1/0 - 14 AWG								
	Load	4	4 - 14 AWG	6 - 14 AWG								
Type 4	Line	1	250 - 2 kcmil	4/0 - 2 AWG								
	Load	6	2 - 14 AWG	4 - 14 AWG								
Type 5	Line	1	500 - 2/0 kcmil	400 - 2/0 kcmil								
	Load	6	8 - 14 AWG	4 - 14 AWG								

Power Distribution Blocks

Distribution

Power Distribution Blocks

General Characteristics

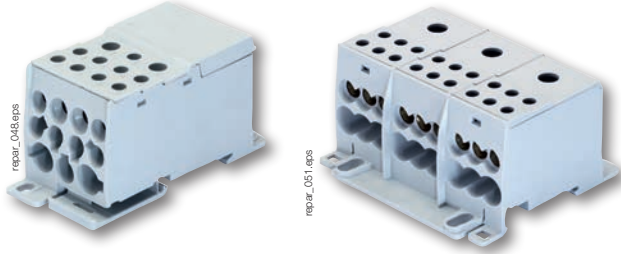

- Material: tin plated aluminum
- Suitable conductors: aluminum or copper
- IP20 finger-safe
- DIN Rail mounting
- Panel mounting
- Voltage Ratings: 600 VAC/DC

References

Type	Nb poles	Rating (A)		References
		Cable Cu	Cable Al	
Type 1	1 P	115	90	5411 1012
Type 2	1 P	115	90	5411 1013
Type 3	1 P	175	135	5411 1017
Type 4	1 P	255	-	5411 1025
Type 5	3 P	175	135	5411 3017
Accessory				References
Type 4 connection for devices				5410 0025

Dimensions (in/mm)

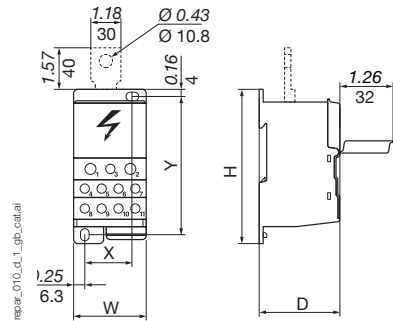

Direct or cable connection distribution blocks, IP20 which can be clipped onto a symmetric DIN rail.

Type	Units	Dimensions H x W x D	Mounting	
			A	B
Type 1	in	2.91 x 1.06 x 1.81	2.44	0.157
	mm	74 x 27 x 46	62	4
Type 2	in	2.80 x 1.77 x 1.69	2.386	0.685
	mm	71 x 45 x 43	60.6	17.4
Type 3	in	2.80 x 1.77 x 1.69	2.386	0.685
	mm	71 x 45 x 43	60.6	17.4
Type 4	in	3.74 x 1.75 x 1.93	3.836	1.165
	mm	95 x 44.5 x 49	86	29.6
Type 5	in	2.8 x 3.15 x 1.93	2.382	2.07
	mm	72 x 80 x 43	60.6	52.5

Connections & Electrical Characteristics

Type	For connection	Number of holes	Solid / stranded wired	Fine wire with sleeve	1059 Voltage Max.		Short circuit withstanding							
			Connection	Connection	AC (V)	DC (V)	I _{cw} (kA)	I _{pk} (kA)						
Type 1	Line	1	2 - 8 AWG	2 - 8 AWG	600	600	4.2	30						
	Line	1	4 - 14 AWG	6 - 14 AWG										
	Load	6	4 - 14 AWG	6 - 14 AWG										
Type 2	Line	1	2 - 8 AWG	2 - 8 AWG			600	600	4.2	30				
	Load	10	4 - 14 AWG	6 - 14 AWG										
Type 3	Line	1	2/0 - 8 AWG	1/0 - 8 AWG					600	600	11	30		
	Load	10	4 - 14 AWG	6 - 14 AWG										
Type 4	Line	1	250 - 2 kcmil	4/0 - 2 AWG							600	600	21	51
	Load	2	2 - 14 AWG	4 - 14 AWG										
	Load	5	6 - 14 AWG	6 - 14 AWG										
	Load	4	8 - 14 AWG	8 - 14 AWG										
Type 5	Line	1	2/0 - 8 AWG	1/0 - 8 AWG	600	600							11	30
	Load	6	4 - 14 AWG	6 - 14 AWG										

Rigid Copper Bars

Busbar

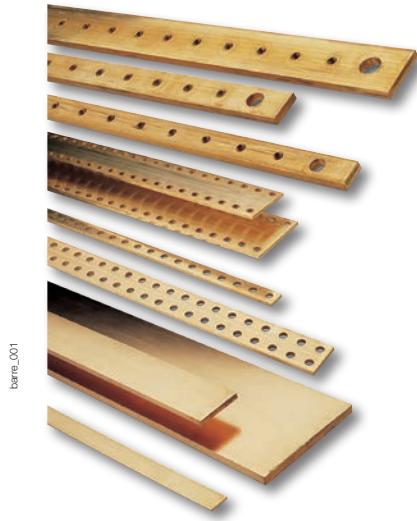

bars_001

Function

The SOCOMEC **Rigid Copper Bars** are suitable for providing main or distribution connections.

Composition of the range

Solid bars

- Thickness: 4.5 and 10 mm
- Width: 20 to 160 mm
- Length: 1750, 2900, 5800 mm

Pre-punched bars

- Thickness: 5 and 10 mm
- Width: 25 to 125 mm
- Length: 1750 mm

Pre-punched and threaded bars

- Thickness: 5 mm
- Width: 15 to 32 mm
- Length: 990mm

Solid bars

- Determination of the admissible current I_z (A) for solid bars, in usual use conditions (Temperature ambient 113°F / 45°C, admissible warming of the bars 95°F / 35°C, 50 Hz current)

Pre-punched copper bars

- For the pre-punched bars of same dimensions as the solid bars: pre-punched $I_z = 0.9 I_z$ solid

Aluminium bars

- For the aluminium bars of same dimensions as the solid bars: I_z aluminium = 0.78 I_z solid copper

Connector for drill-free connection on the busbar

- Bars for thickness 10 mm

Connection Earth / Neutral

- Corner piece for Earth / Neutral connection, L = 1750 mm
- Earth bar, L = 470 mm and L = 120 mm

The solution for

- > Industrial Control Panel Manufacturers (UL 508A)
- > Switchboards Manufacturers (UL 891)
- > Distributors
- > OEM/Machine Builders



Amperage per number of Edgewise Mounting

Bar section l x e (mm)	Number of bars per phase			
	I	II	III	IIII
20 x 4	240	430	600	750
15 x 5	220	390	540	650
25 x 5	330	590	800	1000
32 x 5	410	700	1000	1250
40 x 5	500	850	1200	1500
50 x 5	600	1050	1450	1850
63 x 5	700	1250	1800	2250
80 x 5	900	1550	2200	2750
100 x 5	1100	1900	2650	3350
125 x 5	1300	2350	3250	4100
30 x 10	600	1050	1450	1800
50 x 10	850	1550	2150	2700
60 x 10	1000	1800	2400	3150
80 x 10	1300	2300	3200	4000
100 x 10	1550	2750	3850	4850
125 x 10	1900	3350	4650	5900
160 x 10	2350	4150	5800	7300

Flat Mounting

Bar section l x e (mm)	Number of bars per phase			
	I	II	III	IIII
20 x 4	210	340	460	570
15 x 5	190	310	420	510
25 x 5	280	470	600	750
32 x 5	350	580	750	950
40 x 5	420	700	900	1150
50 x 5	510	850	1100	1400
63 x 5	620	1000	1350	1700
80 x 5	750	1250	1700	2100
100 x 5	900	1500	2050	2550
125 x 5	1100	1850	2500	3050
30 x 10	490	800	1100	1350
50 x 10	750	1200	1650	2050
60 x 10	850	1400	1900	2350
80 x 10	1100	1800	2450	3000
100 x 10	1350	2200	2950	3650
125 x 10	1600	2700	3600	4400
160 x 10	2000	3300	4450	5500

References

Solid Bars

l x e (mm)	Weight (kg/ml)	L = 1750 mm	L = 2900 mm	L = 5800 mm
		To be ordered in multiples of 1 bar	To be ordered in multiples of 1 bar	To be ordered in multiples of 5 or 10 bars
		Reference	Reference	Reference
20 x 4	0.71	4510 2004	4513 2004	4514 2004 ⁽¹⁾
25 x 5	1.11	4510 2505	4513 2505	4514 2505 ⁽¹⁾
32 x 5	1.42	4510 3205	4513 3205	4514 3205 ⁽¹⁾
40 x 5	1.78	4510 4005	4513 4005	4514 4005 ⁽¹⁾
50 x 5	2.22	4510 5005	4513 5005	4514 5005 ⁽¹⁾
63 x 5	2.80	4510 6305	4513 6305	4514 6305 ⁽¹⁾
80 x 5	3.56	4510 8005	4513 8005	4514 8005 ⁽²⁾
100 x 5	4.45	4510 9005	4513 9005	4514 9005 ⁽²⁾
125 x 5	5.56	4510 9205	4513 9205	4514 9205 ⁽²⁾
30 x 10	2.67	4510 3010	4513 3010	4514 3010 ⁽²⁾
50 x 10	4.45	4510 5010	4513 5010	4514 5010 ⁽²⁾
60 x 10	5.33	4510 6010	4513 6010	4514 6010 ⁽²⁾
80 x 10	7.11	4510 8010	4513 8010	4514 8010 ⁽²⁾
100 x 10	8.89	4510 9010	4513 9010	4514 9010 ⁽²⁾
125 x 10	11.11	4510 9210	4513 9210	4514 9210 ⁽²⁾
160 x 10	14.22	4510 9610	4513 9610	4514 9610 ⁽²⁾

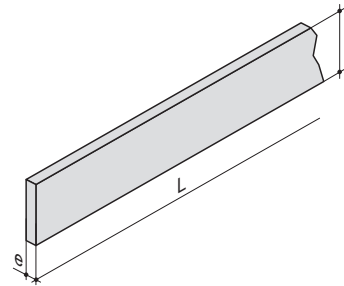

barre_002_a_1_x_cat

(1) To be ordered by multiple 10 bars
(2) To be ordered by multiple 5 bars

Pre-Punched Bars

l x e (mm)	W (mm)	Weight (kg/ml)	No. of rows	To be ordered in multiples of	Reference
25 x 5	1750	1.11	1	5	4511 2505
50 x 5	1750	2.22	2	5	4511 5005
63 x 5	1750	2.80	2	5	4511 6305
80 x 5	1750	3.56	2	5	4511 8005
100 x 5	1750	4.45	2	5	4511 9005
125 x 5	1750	5.56	2	5	4511 9205
50 x 10	1750	4.45	2	5	4511 5010
60 x 10	1750	5.33	2	5	4511 6010
80 x 10	1750	7.11	2	5	4511 8010
100 x 10	1750	8.89	2	5	4511 9010
125 x 10	1750	10.70	2	5	4511 9210

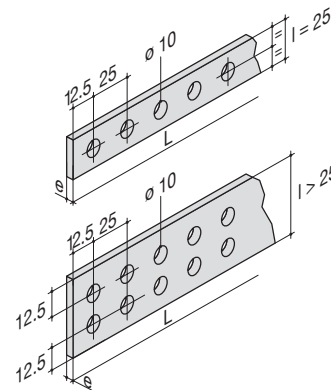

barre_003_a_1_x_cat

Pre-Punched and Threaded Bars

l x e (mm)	W (mm)	Weight (kg/ml)	Ø A (mm)	To be ordered in multiples of	Reference
15 x 5	990	0.67 kg	8.2	5	4512 1505
20 x 5	990	0.89 kg	10.2	5	4512 2005
32 x 5	990	1.42 kg	12.2	5	4512 3205

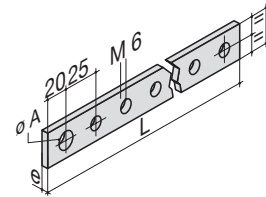

barre_004_a_1_x_cat

Accessories

Drill-Free Connection Accessories

Use

- Allows for drill-free connection of flexible bars or cables onto a busbar
- Connection across 2 bars, 10 mm thick, placed side by side, 10 mm apart
- Compatible with busbar supports in the SBC range
- For terminals or flexible bars with widths greater than 40 mm, use 2 connection accessories
- Secured with M10 screws, tightening torque 45Nm
- To make a connection: Use 1 securing clamp and 1 screw adapted to the height of the bars are required

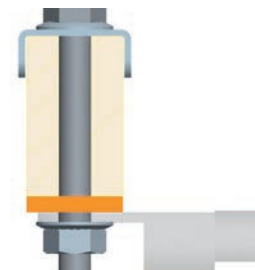

barre_000_a_1_x_cat

Type	Bar (mm)	To be ordered in multiples of	Reference
Securing clamp M10	all	12	5119 4423
Screw M10	30	100	5119 4503
Screw M10	50	100	5119 4505
Screw M10	60	100	5119 4506
Screw M10	80	100	5119 4508
Screw M10	100	100	5119 4510
Screw M10	125	100	5119 4512

Insulated Flexible Copper Bars

Busbar



Function

SOCOMECC **Insulated Flexible Copper Bars** are mainly used for providing the power connections between busbars and the disconnection devices inside an electrical panel.

The insulated layered copper allows the flexible copper bar to be easily bent to provide a customised solution.

Advantages

Easy Installation

- Compact version
- High level of flexibility enabling easy manipulation of the busbar
- Reduced installation time with the elimination of terminal lugs and their crimping

Increased Safety

- Elimination of crimped connections
 - » Better behavior under short-circuit conditions.
 - » Decreased number of heating points.
 - » More reliable connections.

Characteristics

- Width of 9 to 100 mm.
- Copper layer thickness from 0.8 to 1 mm.
- Length of 6.56 ft / 2 m.

Conductor

- Layers of electrolytic copper Cu/ETP, final annealing state.

Insulator

- High temperature co-extruded vinyl compound on the copper strips (insulation thickness: 1.5 to 2 mm)
- Self-extinguishing: NFC 32200 and UL 94 V0
- Continuous temperature withstand: 221 °F / 105 °C
- Shore hardness A: 89 +/- 2
- Module 100 % elongation: 16 Mpa
- Resistance to elongation: < 15 % mini
- Breaking stress: 20 Mpa
- Transversal volume resistivity: 6.1015 Ω
- Oxygen index: 29.5 %
- Scratch and tear resistant

Insulated flexible busbar

- Operating-temperature range: from -40 °F / -40 °C to + 221 °F / +105 °C
- Maximum operating voltage: 1000 VAC / 1500 VDC
- Alternating voltage withstand (10 minute test):
 - » between core and insulation: 16.5 kV
 - » between two insulating elements in contact: 33 kV
 - » Conductivity: 100 IACS
 - » HV < 50
 - » Resistance to traction $R_m > 200 \text{ N/cm}^2$
 - » Stretch before break 35 %
 - » Resistivity: 1.724 micro Ω/cm at 68 °F / 20 °C

The solution for

- > Industrial Control Panels Manufacturers (UL 508A)
- > Switchboards Manufacturers (UL 891)
- > Distributors
- > OEM/Machine Builders



Strong points

- > Easy to install
- > Increased safety by the elimination of crimped connections

Conformity to standards

- > UL 67 and UL 891
CSA-C22.2
No. 29 and 244
Guide QUEY
File E495516



References

I x N x e (mm)	L (mm)	Permissible amperage for ΔT (°C) ⁽¹⁾			To be ordered in multiples of	Reference
		104°F / 40°C (A)	122°F / 50°C (A)	140°F / 60°C (A)		
9 x 2 x 0.8	2000	113	129	143	1	4518 0902
9 x 3 x 0.8	2000	140	160	178	1	4518 0903
9 x 4 x 0.8	2000	165	188	209	1	4518 0904
9 x 5 x 0.8	2000	187	214	238	1	4518 0905
9 x 6 x 0.8	2000	208	238	264	1	4518 0906
13 x 3 x 0.5	2000	142	162	180	1	4518 1303
13 x 4 x 0.5	2000	165	189	210	1	4518 1304
13 x 5 x 0.5	2000	186	213	237	1	4518 1305
13 x 6 x 0.5	2000	206	235	261	1	4518 1306
15.5 x 2 x 0.8	2000	167	191	212	1	4518 1502
15.5 x 3 x 0.8	2000	207	237	263	1	4518 1503
15.5 x 4 x 0.8	2000	242	277	308	1	4518 1504
15.5 x 6 x 0.8	2000	304	347	386	1	4518 1506
15.5 x 8 x 0.8	2000	358	409	455	1	4518 1508
15.5 x 10 x 0.8	2000	408	466	519	1	4518 1510
20 x 2 x 1	2000	228	261	290	1	4518 2002
20 x 3 x 1	2000	283	324	360	1	4518 2003
20 x 4 x 1	2000	331	378	421	1	4518 2004
20 x 5 x 1	2000	374	428	476	1	4518 2005
20 x 6 x 1	2000	415	474	527	1	4518 2006
20 x 8 x 1	2000	488	558	621	1	4518 2008
20 x 10 x 1	2000	556	635	705	1	4518 2010
24 x 2 x 1	2000	263	301	335	1	4518 2402
24 x 3 x 1	2000	326	373	414	1	4518 2403
24 x 4 x 1	2000	380	435	483	1	4518 2404
24 x 5 x 1	2000	429	491	546	1	4518 2405
24 x 6 x 1	2000	475	542	603	1	4518 2406
24 x 8 x 1	2000	557	636	708	1	4518 2408
24 x 10 x 1	2000	632	722	803	1	4518 2410
32 x 2 x 1	2000	331	379	421	1	4518 3202
32 x 3 x 1	2000	409	468	520	1	4518 3203
32 x 4 x 1	2000	476	544	605	1	4518 3204
32 x 5 x 1	2000	536	612	681	1	4518 3205
32 x 6 x 1	2000	591	675	751	1	4518 3206
32 x 8 x 1	2000	689	787	876	1	4518 3208
32 x 10 x 1	2000	777	887	987 ⁽¹⁾	1	4518 3210
40 x 2 x 1	2000	398	455	506	1	4518 4002
40 x 3 x 1	2000	490	560	623	1	4518 4003
40 x 4 x 1	2000	569	650	723	1	4518 4004
40 x 5 x 1	2000	639	730	812	1	4518 4005
40 x 6 x 1	2000	703	803	893	1	4518 4006
40 x 8 x 1	2000	815	932	1036	1	4518 4008
40 x 10 x 1	2000	915	1045	1163	1	4518 4010
50 x 3 x 1	2000	589	673	749	1	4518 5003
50 x 4 x 1	2000	682	780	867	1	4518 5004
50 x 5 x 1	2000	764	873	971	1	4518 5005
50 x 6 x 1	2000	838	957	1062	1	4518 5006
50 x 8 x 1	2000	967	1105	1229	1	4518 5008
50 x 10 x 1	2000	1080	1234	1373	1	4518 5010
63 x 3 x 1	2000	715	816	908	1	4518 6303
63 x 4 x 1	2000	825	943	1048	1	4518 6304
63 x 5 x 1	2000	921	1052	1171	1	4518 6305
63 x 6 x 1	2000	1041	1187	1324	1	4518 6306
63 x 8 x 1	2000	1157	1321	1470	1	4518 6308
63 x 10 x 1	2000	1286	1469	1634	1	4518 6310
80 x 3 x 1	2000	874	998	1110	1	4518 8003
80 x 4 x 1	2000	1006	1149	1278	1	4518 8004
80 x 5 x 1	2000	1119	1279	1422	1	4518 8005
80 x 6 x 1	2000	1220	1393	1550	1	4518 8006
80 x 8 x 1	2000	1393	1592	1771	1	4518 8008
80 x 10 x 1	2000	1543	1763	1961	1	4518 8010
100 x 4 x 1	2000	1211	1383	1538	1	4518 9004
100 x 5 x 1	2000	1343	1534	1707	1	4518 9005
100 x 6 x 1	2000	1460	1668	1855	1	4518 9006
100 x 8 x 1	2000	1660	1897	2110	1	4518 9008
100 x 10 x 1	2000	1833	2094	2329	1	4518 9010
100 x 12 x 1	2000	1993	2277	2531	1	4518 9012

Implementation

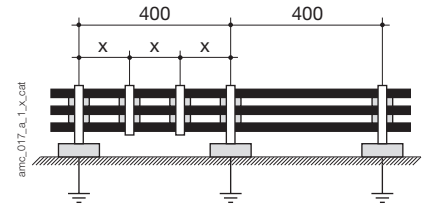

Flexible bars should be mounted on insulated supports with a maximum distance of 400 mm. Bars should also be held together with straps, as shown in the above diagram. The distance between successive straps depends on the electro-dynamic constraints in the event of a short-circuit. The table below gives the recommended distances between straps.

I _{sc} max. (kA rms)	Distance x between straps (mm) ⁽¹⁾
20	350
25	200
35	100
45	70

(1) 9 mm straps, load 176 lbs / 80 kg.

Parallel Systems

Putting bars in parallel increases the temperature of the air near the bar, which forms a reduction coefficient

No. of barres in parallel	Aamperage at ΔT 104°F/40°C	Correction factor
I	any intensity	1
II	< 900A	1,72
II	> 900A	1,65
III	< 900A	2,25
III	> 900A	2,12

(1) For ambient air temperature of 104 °F / 40 °C
Important: max. busbar temperature = 221 °F / 105 °C

L: length of bar in metres
l: width of bare busbar in mm
N: number of copper layers
e: copper layer thickness in mm

Insulated Copper Braids

Busbar



barrm_023_eps

barrm_022_eps

Function

SOCOMEK **Insulated Copper Braids** are mainly utilized for providing the power connections between distribution busbars and the devices within an electrical panel.

Their flexibility is particularly suited to complex and diverse connections in confined spaces.

Technical characteristics

- Electrolytic copper, annealing state
- Operating voltage 1000 VAC - 1500 VDC
- Dielectric strength 20 KV/mm
- Operating temperature: -40° - 221°F | 40° - 105°C
- Self-extinguishing: UL 94 V0
- Contact surface: Bare copper

Advantages

Easy Installation

- Compact design
- Length and orientation are easily adapted
- Prewired

Application Variety

- Amperage up to 1000 A
- Suitable for various connection ranges
- Lengths from 7.87 - 31.5in | 200 - 800mm

Compatibility

- With SOCOMEK devices
- With most commercial circuit breakers

The solution for

- > Industrial Control Panels Manufacturers (UL 508A)
- > Switchboards Manufacturers (UL 891)
- > Distributors
- > OEM/Machine Builders



Strong points

- > Easy Installation
- > Application Variety
- > Compatibility

References

Current rating at ambient temperature of 630 to 7000 A			Reference	Section mm ²	Dimensions										Range		Weight (lb)
95°F / 35°C (A)	Nominal rating 113°F / 45°C (A)	131°F / 55°C (A)			A Width (mm)	e Thickness (mm)	X Distance (mm)	L Length (mm)	Ø 1 (mm)	Ø 2 (mm)	C1 (mm)	C2 (mm)	h Width (mm)	f Thickness (mm)	B1 (mm)	B2 (mm)	
180	160	140	4516 1620	25	20	1.5	200	220	8.5	10.5	8	12	22	3.5	25	30	0.17
180	160	140	4516 1625	25	20	1.5	250	270	8.5	10.5	8	12	22	3.5	25	30	0.19
180	160	140	4516 1630	25	20	1.5	300	320	8.5	10.5	8	12	22	3.5	25	30	0.24
180	160	140	4516 1635	25	20	1.5	350	370	8.5	10.5	8	12	22	3.5	25	30	0.26
180	160	140	4516 1640	25	20	1.5	400	420	8.5	10.5	8	12	22	3.5	25	30	0.31
180	160	140	4516 1650	25	20	1.5	500	520	8.5	10.5	8	12	22	3.5	25	30	0.37
280	250	220	4516 2520	50	20	3	200	220	8.5	10.5	8	12	22	5	25	30	0.31
280	250	220	4516 2525	50	20	3	250	270	8.5	10.5	8	12	22	5	25	30	0.35
280	250	220	4516 2530	50	20	3	300	320	8.5	10.5	8	12	22	5	25	30	0.42
280	250	220	4516 2535	50	20	3	350	370	8.5	10.5	8	12	22	5	25	30	0.49
280	250	220	4516 2540	50	20	3	400	420	8.5	10.5	8	12	22	5	25	30	0.55
280	250	220	4516 2550	50	20	3	500	520	8.5	10.5	8	12	22	5	25	30	0.66
440	400	320	4516 4020	120	32	5	200	222	10.5	10.5	10	12	34	7	25	30	0.66
440	400	320	4516 4025	120	32	5	250	272	10.5	10.5	10	12	34	7	25	30	0.79
440	400	320	4516 4030	120	32	5	300	322	10.5	10.5	10	12	34	7	25	30	0.95
440	400	320	4516 4035	120	32	5	350	372	10.5	10.5	10	12	34	7	25	30	1.08
440	400	320	4516 4040	120	32	5	400	422	10.5	10.5	10	12	34	7	25	30	1.23
440	400	320	4516 4050	120	32	5	500	522	10.5	10.5	10	12	34	7	25	30	1.52
440	400	320	4516 4060	120	32	5	600	622	10.5	10.5	10	12	34	7	25	30	1.81
440	400	320	4516 4080	120	32	5	800	822	10.5	10.5	10	12	34	7	25	30	2.36
690	630	560	4516 6325	240	32	10	250	274	12.5	10.5	12	12	34	12	35	30	1.57
690	630	560	4516 6330	240	32	10	300	324	12.5	10.5	12	12	34	12	35	30	1.85
690	630	560	4516 6335	240	32	10	350	374	12.5	10.5	12	12	34	12	35	30	2.12
690	630	560	4516 6340	240	32	10	400	424	12.5	10.5	12	12	34	12	35	30	2.40
690	630	560	4516 6350	240	32	10	500	524	12.5	10.5	12	12	34	12	35	30	2.98
690	630	560	4516 6360	240	32	10	600	624	12.5	10.5	12	12	34	12	35	30	3.53
690	630	560	4516 6380	240	32	10	800	824	12.5	10.5	12	12	34	12	35	30	4.63

Dimensions

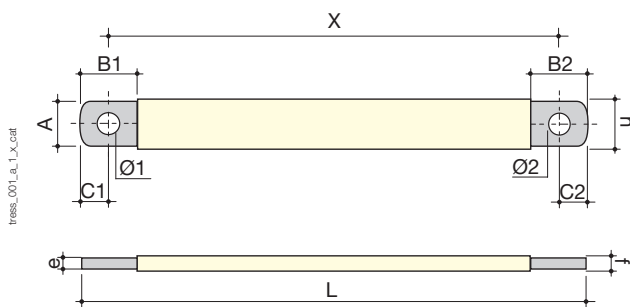

Parallel Systems

Putting braids in parallel increases the temperature of the air near the braid, which forms a reduction coefficient

Correction factor	Current
	Current
	2 x current x 0.8
	3 x current x 0.65

Busbar Supports

Busbar

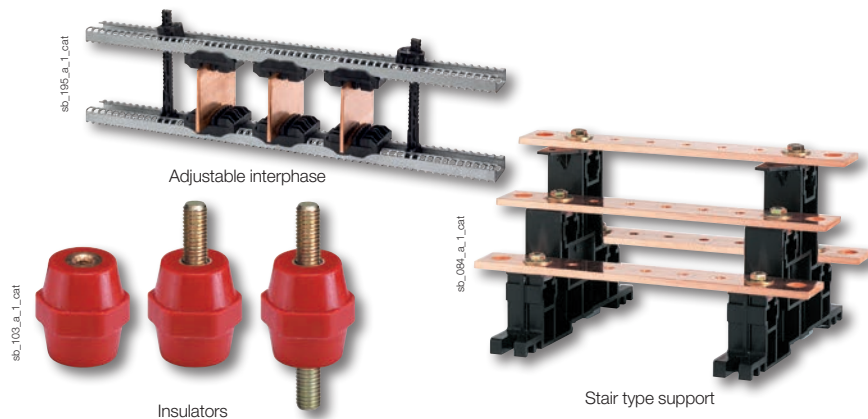

Function

SOCOMEK **Insulating Busbar Supports** enable the fixing of copper or aluminium busbars.

Characteristics

Insulators

- Polyester without halogen
- UL94 VO self-extinguishing
- Color red RAL 3002
- Operating temperature from -40 to 266°F
- Deformation under load temperature (ASTM D643): > 392°F / 200°C
- Dielectric constant (ASTM D150): 4/5
- Arc resistance (ASTM D495): > 180 s
- Water absorption (ASTM D570): < 0.3%

Busbar supports

- High dielectric strength
- High mechanical resistance
- Non-magnetic assembly parts
- High resistance to damp heat (supplied "with a conformal coating")

Stair type supports

- Thermoplastic material
- UL 94 VO self-extinguishing
- Insulating voltage: 1000 V

The solution for

- > Industrial Control Panels Manufacturers (UL 508A)
- > Switchboards Manufacturers (UL 891)
- > Distributors
- > OEM/Machine Builders



Approvals and Certifications

- > ASEFA/LCIE



(1) Product references on request.

Available on request

- > Please contact us

Software tool for size selection

Mechanical Systems is a software that can be utilized to size bar sets. It defines the configuration of the busbar system, including bar section and distance between supports, according to the required electrical characteristics of the panel in compliance with standard IEC 61439-1. The software runs on Windows® 7 and 10.

Visit our website www.socomec.us.



Selection Guide

Edgewise Mounting

Nominal current I_n

I_{cc} up to 80 kA

- Busbar supports with adjustable interphase

Flat Mounting

- **Unipolar** busbar supports

Nominal current I_n

I_{cc} up to 80 kA

I_{cc} up to 50 kA

I_{cc} up to 80 kA

- **Multipolar** busbar supports

Other Supports

- **Unipolar** busbar supports

Nominal current I_n

I_{cc} up to 50 kA

1. Hexagonal insulators
2. *SB 1* and *SB 2*
3. *SB 3*
4. *SB E 44*
5. *SB P 10*
6. *SB P 44*

I_{cc} up to 30 kA

I_{cc} up to 40 kA

- **4 Pole** busbar supports

Busbar Supports

Busbar

SB C ER P multipolar edgewise mounting busbar supports with adjustable interphase

References

Complete busbar support

Designation	Thickness of bar (mm)	Width of bar (mm)	No. of bars	No. of poles	Reference
Complete support	10	480	1 ... 3	4	5025 5135

Insert

Designation	Thickness of bar (mm)	No. of bars	No. of poles	Quantity	To be ordered in multiples of	Reference
Insert for 5 mm bars	5	3	3 P	6 ⁽¹⁾	8	5025 5205
Insert for 5 mm bars	5	3	4 P	8 ⁽¹⁾	8	5025 5205
Insert for 10 mm bars	10	2	3 P	6 ⁽¹⁾	4	5025 5210
Insert for 10 mm bars	10	2	4 P	8 ⁽¹⁾	4	5025 5210
Insert for 10 mm bars	10	3	3 P	6 ⁽¹⁾	1	5025 5111
Insert for 10 mm bars	10	3	4 P	8 ⁽¹⁾	1	5025 5111

Mounting accessories

Designation	Length (mm)	Quantity	To be ordered in multiples of	Reference
Stud kit (bar height 25 to 200 mm)		2 ⁽¹⁾	4	5025 5100
Stud kit metal (bar height 0 to 100 mm)		2	2	5025 5101
Stud kit metal (bar height 0 to 200 mm)		2	2	5025 5102
380 mm profile	380	2 ⁽¹⁾	4	5025 5124
480 mm profile	480	2 ⁽¹⁾	4	5025 5125
580 mm profile	580	2 ⁽¹⁾	4	5025 5126
780 mm profile	780	2 ⁽¹⁾	4	5025 5128
2 m profile	2000		4	5025 5120
Profile for Prisma enclosure ⁽²⁾	525	1 ⁽¹⁾	1	5025 5130

(1) Quantity required for 1 busbar support inserts.

(2) Kit of 2 profiles and 4 brackets.

Characteristics

5 mm inserts for up to 3 bars and 10 mm inserts for up to 2 bars

peak I_{sc}	L max. (support bars in mm) for					d min. (mm)	Iz (A) ⁽¹⁾
	82 kA	114 kA	152 kA	165 kA	187 kA		
rms I_{sc}	39 kA	52 kA	69 kA	75 kA	85 kA		
Bar x qty						d min. (mm)	Iz (A) ⁽¹⁾
50 x 5 x 1	500	325	175	150		75	600
50 x 5 x 2	500	325	175	150	100	75	1050
50 x 5 x 3	500	325	175	150	100	75	1450
63 x 5 x 1	525	350	200	175		75	700
63 x 5 x 2	525	350	200	175	125	75	1250
63 x 5 x 3	525	350	200	175	125	75	1800
80 x 5 x 1	525	350	200	175	125	75	900
80 x 5 x 2	525	350	200	175	125	75	1550
80 x 5 x 3	525	350	200	175	125	75	2200
100 x 5 x 1	550	375	225	200	175	75	1100
100 x 5 x 2	550	375	225	200	175	75	1900
100 x 5 x 3	550	375	225	200	175	75	2650
125 x 5 x 1	575	400	250	225	200	75	1300
125 x 5 x 2	575	400	250	225	200	75	2350
125 x 5 x 3	575	400	250	225	200	75	3250
80 x 10 x 1	1000	750	350	300	200	75	1300
80 x 10 x 2	1000	750	350	300	200	75	2300
100 x 10 x 1	1000	750	375	325	225	75	1550
100 x 10 x 2	1000	775	375	325	225	75	2750
125 x 10 x 1	1000	775	375	325	225	75	1900
125 x 10 x 2	1000	775	375	325	225	75	3350
160 x 10 x 1	1000	775	400	350	250	75	2350
160 x 10 x 2	1000	800	400	350	250	75	4150

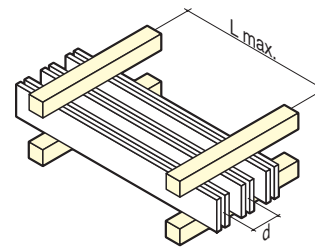

Adhering to the **maximum distance** between two supports ensures that the busbar supports are able to withstand the given short circuit current values. At these limits, distortion of the copper bars may occur. These deformations are permitted by standard IEC 61439-1 so long as they adhere to the insulation distances.

(1) Admissible busbar nominal current with a temperature inside the panel of between 113°F and 176°F.

For other mounting configurations, please contact us.

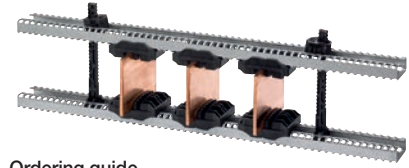

sc_196.png

Ordering guide

- For three poles, order: 6 x inserts, 2 x studs, 2 x profiles.
- For four poles, order: 8 x inserts, 2 x studs, 2 x profiles.

Characteristics (continued)

10 mm insert / 3 bars

peak I_{sc}	L max. (bar supports in mm)						d (mm)	I_z (A) ⁽¹⁾
	63 kA	82 kA	114 kA	152 kA	165 kA	187 kA		
rms I_{sc}	30 kA	39 kA	52 kA	69 kA	75 kA	85 kA		
Bar x qty								
50 x 10 x 1	1000	1000	650	250	200	150	70	850
50 x 10 x 2	1000	1000	650	250	200	150	70	1550
50 x 10 x 3	1000	1000	650	250	200	150	70	2150
63 x 10 x 1	1000	1000	675	275	225	175	70	1050
63 x 10 x 2	1000	1000	675	275	225	175	70	1850
63 x 10 x 3	1000	1000	675	275	225	175	70	2600
80 x 10 x 1	1000	1000	700	300	250	175	70	1300
80 x 10 x 2	1000	1000	700	300	250	175	70	2300
80 x 10 x 3	1000	1000	700	300	250	175	70	3200
100 x 10 x 1	1000	1000	725	325	275	175	70	1550
100 x 10 x 2	1000	1000	725	325	275	175	70	2750
100 x 10 x 3	1000	1000	725	325	275	175	70	3250
125 x 10 x 1	1000	1000	725	350	275	200	70	1900
125 x 10 x 2	1000	1000	725	350	275	200	70	3350
125 x 10 x 3	1000	1000	725	350	275	200	70	4650
160 x 10 x 1	1000	1000	750	350	300	200	70	2350
160 x 10 x 2	1000	1000	750	350	300	200	70	4150
160 x 10 x 3	1000	1000	750	350	300	200	70	5800

(1) Admissible busbar nominal current with a temperature inside the panel of between 113°F and 176°F.

For other mounting configurations, please contact us.

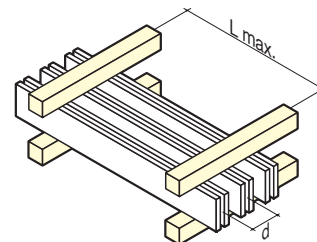

sb_021_Lb_1_X_cat.eps

Adhering to the **maximum distance** between two supports ensures that the busbar supports are able to withstand the given short circuit current values. At these limits, distortion of the copper bars may occur. These deformations are permitted by standard IEC 61439-1 so long as they adhere to the insulation distances.

Dimensions

Mounting

- 1 to 3 bars of 5 mm thickness, per phase
- 1 to 3 bars of 10 mm thickness, per phase
- Interphase distance: min. 70 mm and max 200 mm
- Use 2 studs positioned symmetrically on the extremity of the poles or between the outermost poles

A (mm)	Enclosure (mm)
380	400
480	500
580	600
780	800

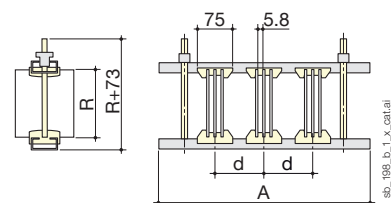

5 mm insert / 3 bars

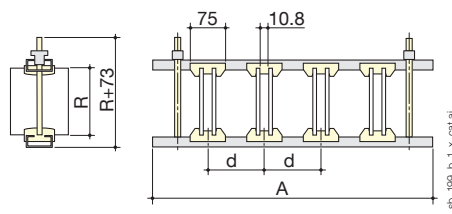

10 mm insert / 2 bars

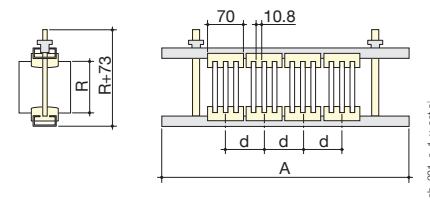

10 mm insert / 3 bars

Busbar Supports

Busbar

SB 205 - SB 306 unipolar flat mounting busbar supports

References

Support	Insulation voltage (VAC)	No. of bars	Bar width (mm)	To be ordered in multiples of	Reference
SB 205	1,000	1 - 3	100	6	5025 5110
SB 306	1,000	1 - 3	160	6	5025 6110



sb_117_pesf

Characteristics

Support	peak I_{sc}	L max. (support bars in mm) for						d min. (mm)	Iz (A) ⁽¹⁾
		48 kA	63 kA	82 kA	114 kA	152 kA	165 kA		
	rms I_{sc}	23 kA	30 kA	39 kA	52 kA	69 kA	75 kA		
Bar x qty									
SB 205	100 x 10 x 1	1000	1000	1000	1000	1000	1000	125	1550
SB 205	100 x 10 x 2	1000	1000	1000	1000	1000	1000	125	2750
SB 205	100 x 10 x 3	1000	1000	1000	1000	1000	1000	125	3850
SB 306	160 x 10 x 1	1000	1000	1000	1000	1000	1000	175	2350
SB 306	160 x 10 x 2	1000	1000	1000	1000	1000	1000	175	4150
SB 306	160 x 10 x 3	1000	1000	1000	1000	1000	1000	175	5800

(1) Admissible busbar nominal current with a temperature inside the panel of between 113°F and 176°F. For other mounting configurations, please contact us.

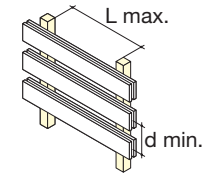
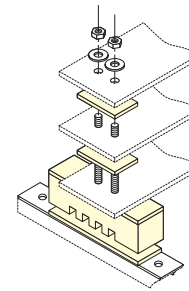

sb_152_a_1_x_cat

Mounting

- SB 205: 1 to 3 bars of max. recommended width 100 mm
- SB 306: 1 to 3 bars of max. recommended width 160 mm

Dimensions

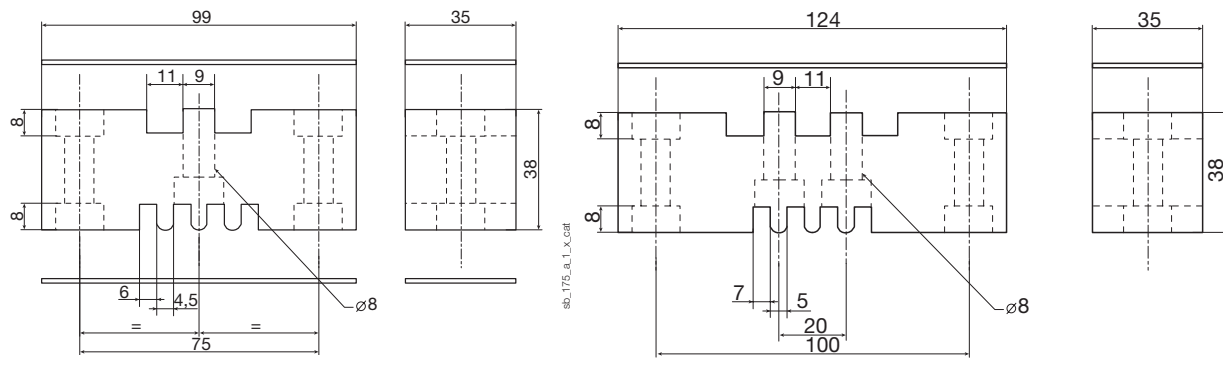

sb_175_a_1_x_cat

sb_176_a_1_x_cat

■ SB 7500 multipolar flat mounting busbar supports with fixed interphase

References

No. of poles	Insulation voltage (VAC)	Bar width (mm)	Pack qty	Reference
3 P	1,000	40 -50	1	5027 5310
4 P	1,000	40 -50	1	5027 5410



Characteristics

peak I_{sc}	L max. (support bars in mm) for						d (mm)	Iz (A)
	24 kA	48 kA	63 kA	82 kA	114 kA	152 kA		
rms I_{sc}	12 kA	23 kA	30 kA	39 kA	52 kA	69 kA		
Bar x qty								
50 x 5 x 1	1000	1000	950	725	525	450	75	600
50 x 5 x 2	1000	1000	1000	1000	975	850	75	1,050

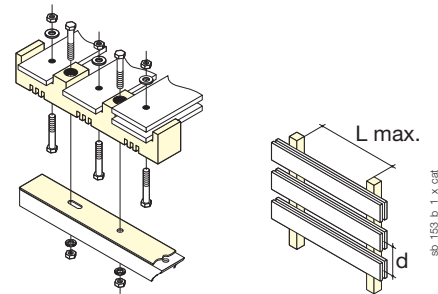

Mounting: SB 7500: 1 to 2 bars of max. width 50 mm per pole. Fixed interphase of 75 mm.

Dimensions

No. of poles	A	B	C	J	R	T ₁	T ₂
3 P	220	38	35	75	52.5	11	6
4 P	295	38	35	75	52.5	11	6

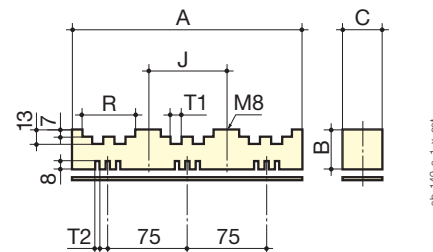

Busbar Supports

Busbar

SB P 30 multipolar flat mounting busbar supports with fixed interphase

References

No. of poles	Insulation voltage (VAC)	Bar width (mm)	Pack qty	Reference
3 P	1000	50 -100	1	5023 0310
4 P	1000	50 -80	1	5023 0410
Mounting bracket				
Accessories		To be ordered in multiples of		Reference
2 mounting brackets for SB P 30		1		5024 9002
Bar fixing screws				
Accessories		To be ordered in multiples of		Reference
Grub screws for mounting 1 bar		25		5119 4601
Grub screws for mounting 2 bars back-to-back		25		5119 4602
Grub screws for mounting 3 back-to-back bars		25		5119 4603

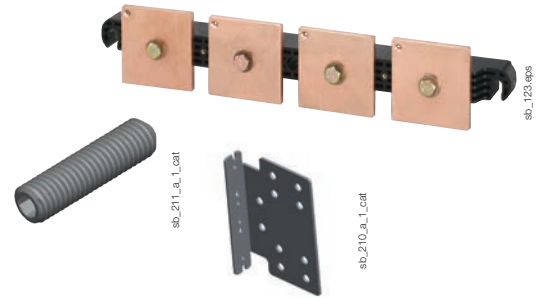

Characteristics

d = 123 mm

peak I _{sc}	L max. (support bars in mm) for								d (mm)	Iz (A)
	63 kA	84 kA	110 kA	143 kA	165 kA	176 kA	187 kA	220 kA		
rms I _{sc}	30 kA	40 kA	50 kA	65 kA	75 kA	80 kA	85 kA	100 kA		
Bar x qty										
50 x 5 x 1	1000	950	525	300	225	200	175	130	123	600
63 x 5 x 1	1000	925	525	300	225	200	175	130	123	700
80 x 5 x 1	1000	900	500	300	225	175	175	125	123	900
80 x 5 x 2	1000	900	500	300	225	175	175	125	123	1,550
50 x 10 x 1	1000	950	525	300	225	200	175	130	123	850
50 x 10 x 2	1000	975	525	300	225	200	175	135	123	1,550
63 x 10 x 1	1000	925	525	300	225	200	175	130	123	1,050
63 x 10 x 2	1000	950	525	300	225	200	175	130	123	1,850
80 x 10 x 1	1000	900	500	300	225	175	175	125	123	1,300
80 x 10 x 2	1000	925	500	300	225	200	175	125	123	2,300
80 x 10 x 3	1000	950	525	300	225	200	175	130	123	3,200

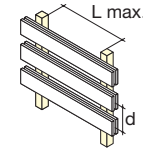
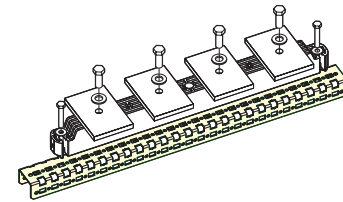

d = 185 mm

peak I _{sc}	L max. (support bars in mm) for								d (mm)	Iz (A)
	63 kA	84 kA	110 kA	143 kA	165 kA	176 kA	187 kA	220 kA		
rms I _{sc}	30 kA	40 kA	50 kA	65 kA	75 kA	80 kA	85 kA	100 kA		
Bar x qty										
50 x 5 x 1	1000	1000	800	475	350	300	275	200	185	
63 x 5 x 1	1000	1000	800	475	350	300	275	200	185	
80 x 5 x 1	1000	1000	800	475	350	300	275	200	185	
80 x 5 x 2	1000	1000	800	475	350	300	275	200	185	
100 x 5 x 1	1000	1000	775	450	325	300	250	175	185	1100
100 x 5 x 2	1000	1000	775	450	325	300	250	175	185	1900
100 x 5 x 3	1000	1000	775	450	350	300	250	175	185	2650
50 x 10 x 1	1000	1000	800	475	350	300	275	200	185	
50 x 10 x 2	1000	1000	800	475	350	300	275	200	185	
63 x 10 x 1	1000	1000	800	475	350	300	275	200	185	
63 x 10 x 2	1000	1000	800	475	350	300	275	200	185	
80 x 10 x 1	1000	1000	800	475	350	300	275	200	185	
80 x 10 x 2	1000	1000	800	475	350	300	275	200	185	
80 x 10 x 3	1000	1000	800	475	350	300	275	200	185	
100 x 10 x 1	1000	1000	775	450	325	300	250	175	185	1550
100 x 10 x 2	1000	1000	775	450	350	300	250	175	185	2750
100 x 10 x 3	1000	1000	775	450	350	300	275	175	185	3850

Mounting

- 3 poles: 1 to 3 bars of max. width 100 mm per pole, fixed interphase of 185 mm
- 4 poles: 1 to 3 bars of max. width 80 mm per pole, fixed interphase of 123 mm

Dimensions

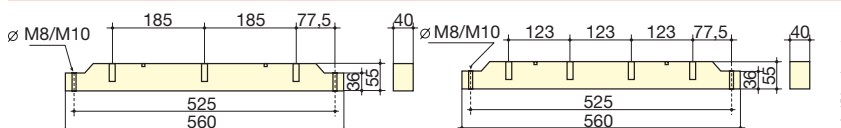

■ Hexagonal insulators unipolar flat mounting busbar supports

Female to female hexagonal insulator

References

Height H (mm)	Threading M	Depth		Diameter E (mm)	Pack qty	Reference
		P (mm)	Pu (mm)			
20	M4	8	5.5	19	10	5031 2004
20	M6	8	5.5	19	10	5031 2006
25	M6	10	7	21	10	5031 2506
30	M6	10	7	33	10	5031 3006
30	M8	12	9	33	10	5031 3008
35	M6	12	9	33	10	5031 3506
35	M8	12	9	33	10	5031 3508
35	M10	12	9	33	10	5031 3510
40	M8	15	12	40	10	5031 4008
40	M10	15	12	40	10	5031 4010
45	M8	15	12	41	10	5031 4508
45	M10	15	12	41	10	5031 4510
50	M8	20	17	46	10	5031 5008
50	M10	20	17	46	10	5031 5010
50	M12	20	17	46	10	5031 5012
60	M10	20	17	50	10	5031 6010
65	M10	20	17	55	10	5031 6510
70	M12	25	21	55	10	5031 7012



sb_104_a_2_cat

Characteristics

Height H (mm)	Threading	Voltage Nominal (V) AC/DC	Insulation voltage (VAC)		Mechanical characteristics (daN)		Tightening torque max. (Nm)
			50 Hz 1 min	Peak	Flexion	Traction	
20	M4	500	3000	5500	70	170	9
20	M6	500	3000	5500	100	190	8
25	M6	500	3000	5500	170	370	12
30	M6	1000	6000	11000	200	650	22
30	M8	1000	6000	11000	360	800	40
35	M6	1400	9000	16000	230	720	25
35	M8	1400	9000	16000	380	900	42
35	M10	1400	9000	16000	320	800	44
40	M8	2000	12000	21500	620	1200	50
40	M10	2000	12000	21500	620	1100	60
45	M8	2000	12000	21500	550	1200	55
45	M10	2000	12000	21500	550	1100	65
50	M8	2000	12000	21500	650	1800	60
50	M10	2000	12000	21500	650	1700	70
50	M12	2000	12000	21500	660	13000	130
60	M10	2400	12000	27000	560	1600	85
65	M10	2400	12000	27000	750	1600	90
70	M12	2400	12000	27000	750	1500	135

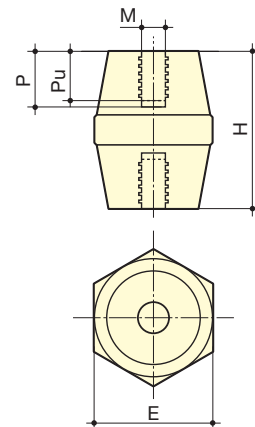

sb_105_c_1_x_cat

Busbar Supports

Busbar

■ Hexagonal insulators unipolar flat mounting busbar supports (continued)

Male to female hexagonal insulator

References

Height	Threading	Depth		Diameter	Length		
H (mm)	M	P (mm)	Pu (mm)	E (mm)	W (mm)	Pack qty	Reference
16	M4	6	5	14	26	10	5038 1604
16	M5	6	5	14	26	10	5038 1605
25	M5	10	7	20	35	10	5038 2505
25	M6	10	7	20	35	10	5038 2506
35	M8	12	9	32	50	10	5038 3508
35	M10	12	9	32	65	10	5038 3510
50	M8	15	17	46	75	10	5038 5008
50	M10	20	17	46	80	10	5038 5010
60	M10	20	17	50	85	10	5038 6010



sb_106_a_2_cat

Male to male hexagonal insulator

References

Height	Threading	Depth		Diameter	Length		
H (mm)	M	P (mm)	Pu (mm)	E (mm)	W (mm)	Pack qty	Reference
16	M4	6	5	14	26	10	5039 1604
16	M5	6	5	14	26	10	5039 1605
25	M5	10	7	20	35	10	5039 2505
25	M6	10	7	20	35	10	5039 2506
35	M8	12	9	32	50	10	5039 3508
35	M10	12	9	32	65	10	5039 3510
50	M8	15	17	46	75	10	5039 5008
50	M10	20	17	46	80	10	5039 5010
60	M10	20	17	50	85	10	5039 6010



sb_107_a_2_cat

Male to female and male to male hexagonal insulator

Characteristics

Height H (mm)	Threading	Voltage Nominal (V) AC/DC	Insulating voltage		Mechanical characteristics (daN)		Tightening torque max. (Nm)
			(VAC) 50 Hz 1 min	Peak	Flexion	Traction	
16	M4	500	3000	5500	100	150	3
16	M5	500	3000	5500	100	150	6
25	M5	500	3000	11000	180	400	6
25	M6	500	3000	11000	180	400	12
35	M8	1400	9000	16000	380	900	42
35	M10	1400	9000	16000	320	800	44
50	M8	2000	12000	21500	650	1800	60
50	M10	2000	12000	21500	650	1700	70
60	M10	2400	12000	27000	560	1600	85

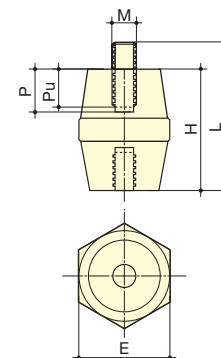

sb_058_d_1_x_cat

Grub Screw

References

Length (mm)	Thread	To be ordered in multiples of	Reference
20	M6	20	5032 2006
20	M8	20	5032 2008
25	M6	20	5032 2506
25	M8	20	5032 2508
30	M6	20	5032 3006
30	M8	20	5032 3008
40	M8	20	5032 4008
40	M10	20	5032 4010
50	M12	20	5032 5012



sb_121_a_2_cat

Define Your Exact Busbar

- > For your busbar, fitted with hexagonal insulators, to be mechanically resistant to a short-circuit, it must correspond to the table below.
Values according to IEC 61439-1.

General Characteristics

Height H (mm)	Threading	Bar x qty	L max. (support bars in mm) for					d min. (mm)	Iz (A) ⁽¹⁾	
			peak I _{sc}	24 kA	48 kA	63 kA	82 kA			114 kA
			rms I _{sc}	12 kA	23 kA	30 kA	39 kA			52 kA
20	M4	15 x 5 x 1	400	100				45	220	
20	M4	20 x 5 x 1	400	100				45	280	
25	M6	15 x 5 x 1	550	135				45	220	
25	M6	20 x 5 x 1	525	135				45	280	
25	M6	25 x 5 x 1	575	145				50	330	
30	M6	15 x 5 x 1	675	165				45	220	
30	M6	20 x 5 x 1	650	165				45	280	
30	M6	25 x 5 x 1	725	175	105			50	330	
30	M8	15 x 5 x 1	850	250	155			45	220	
30	M8	20 x 5 x 1	1000	250	155			45	280	
30	M8	25 x 5 x 1	1000	275	170	100		50	330	
35	M6	15 x 5 x 1	700	175	100			45	220	
35	M6	20 x 5 x 1	675	170	100			45	280	
35	M6	25 x 5 x 1	750	175	110			50	330	
35	M8	15 x 5 x 1	850	275	160			45	220	
35	M8	20 x 5 x 1	1000	275	160			45	280	
35	M8	25 x 5 x 1	1000	300	175	105		50	330	
35	M8	32 x 5 x 1	1000	325	175	110		55	410	
35	M10	20 x 5 x 1	850	200	125			45	280	
35	M10	25 x 5 x 1	950	225	135			50	330	
35	M10	32 x 5 x 1	1000	250	150			55	410	
40	M8	20 x 5 x 1	1000	325	175	110		45	280	
40	M8	25 x 5 x 1	1000	350	200	125		50	330	
40	M8	32 x 5 x 1	1000	375	225	135		55	410	
40	M10	20 x 5 x 1	1000	325	175	110		45	280	
40	M10	25 x 5 x 1	1000	350	200	125		50	330	
40	M10	32 x 5 x 1	1000	375	225	135		55	410	
45	M8	25 x 5 x 1	1000	425	250	150		50	330	
45	M8	32 x 5 x 1	1000	475	275	160		55	410	
45	M8	50 x 5 x 1	1000	625	350	200	110	75	600	
45	M10	25 x 5 x 1	1000	425	250	145		50	330	
45	M10	32 x 5 x 1	1000	450	250	160		55	410	
45	M10	50 x 5 x 1	1000	600	350	200	110	75	600	
50	M8	25 x 5 x 1	1000	450	250	155		50	330	
50	M8	32 x 5 x 1	1000	475	275	170		55	410	
50	M8	50 x 5 x 1	1000	650	375	225	115	75	600	
50	M10	32 x 5 x 1	1000	525	300	175		55	410	
50	M10	50 x 5 x 1	1000	700	400	225	125	75	600	
60	M10	50 x 5 x 1	1000	700	400	225	125	75	600	
65	M10	50 x 5 x 1	1000	775	450	250	135	75	600	

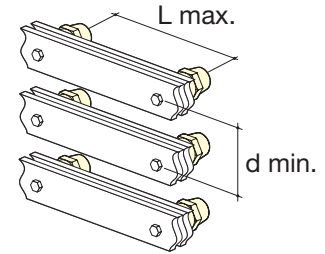

99_164_a_1_x.cnt

(1) Admissible busbar nominal current with a temperature inside the panel of between 113°F and 176°F.
For other mounting configurations, please contact us.

Busbar Supports

Busbar

SB 1 - SB 2 multipolar flat mounting busbar supports

References

Support	Insulation voltage (VAC)	No. of bars	Bar width (mm)	To be ordered in multiples of	Reference
SB 1	690	1	20-25	6	5021 0110
SB 2	690	1	32-40	6	5022 0110



sb_108.psd

Ordering guide

SB 1: bar of max. width 25 mm

SB 2: bar of max. width 40 mm

Characteristics

Support	peak I_{sc}	L max. (support bars in mm) for					d min. (mm)	Iz (A) ⁽¹⁾
		24 kA	48 kA	63 kA	82 kA	114 kA		
	rms I_{sc}	12 kA	23 kA	30 kA	39 kA	52 kA		
	Bar x qty							
SB 1	20 x 3 x 1	650	325	250	175	135	50	210
SB 1	20 x 5 x 1	850	425	325	250	175	50	280
SB 1	25 x 5 x 1	1000	525	400	300	200	50	330
SB 2	32 x 5 x 1	1000	750	575	450	300	70	410
SB 2	40 x 5 x 1	1000	950	700	550	400	70	500

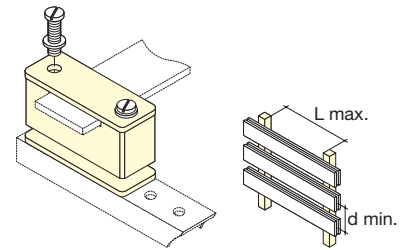

sb_150_a_1_x_cat

(1) Admissible busbar nominal current with a temperature inside the panel of between 113°C and 176°C. For other mounting configurations, please contact us.

Dimensions

Support	A	B	C	J
SB 1	50	23	20	34
SB 2	68	23	23.5	50

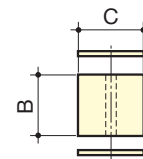
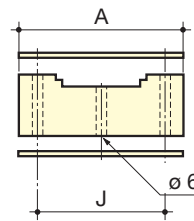

sb_014_c_1_x_cat

■ SB 3 multipolar flat mounting busbar supports

References

Support	Insulation voltage (VAC)	No. of bars	Bar width (mm)	To be ordered in multiples of	Reference
SB 3 without screws	690	1 - 2	32 -63	6	5023 0111
SB 3 with screws ⁽¹⁾	690	1 - 2	32 -63	6	5023 0110

(1) SB 3 bars and with screws.



sb_118.eps

Ordering guide

SB 3: 1 to 2 bars of max. recommended width 63 mm.

Characteristics

peak I_{sc}	L max. (support bars in mm) for						
	24 kA	48 kA	63 kA	82 kA	114 kA		
rms I_{sc}	12 kA	23 kA	30 kA	39 kA	52 kA		
Bar x qty						d min. (mm)	lz (A) ⁽¹⁾
32 x 5 x 2	1000	1000	925	700	500	70	580
40 x 5 x 2	1000	1000	1000	1000	1000	70	700
50 x 5 x 2	1000	1000	1000	925	675	75	850
63 x 5 x 2	1000	1000	1000	1000	1000	85	1000

(1) Admissible busbar nominal current with a temperature inside the panel of between 113°F and 176°F. For other mounting configurations, please contact us.

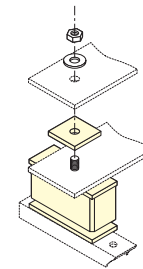

sb_008_a_1_x_cat

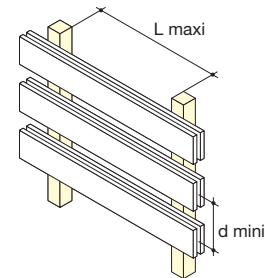

sb_023_b_1_fr_cat

Dimensions

Support	A	B	C	J
SB 3 without screws	65	32	28	36
SB 3 with screws	65	32	28	36

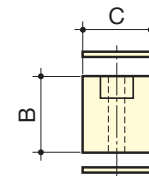
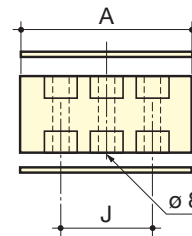

sb_069_b_1_x_cat

Busbar Supports

Busbar

SB E 44 four pole stair type supports

References

No. of poles	Pack qty	Reference
4 P	1	5028 0410
Accessories	Pack qty	Reference
270 mm long protection screen kit	1	5028 0411
420 mm long protection screen kit	1	5028 0412
620 mm long protection screen kit	1	5028 0413
Set of 20 protection screen adaption spacers	1	5028 0415

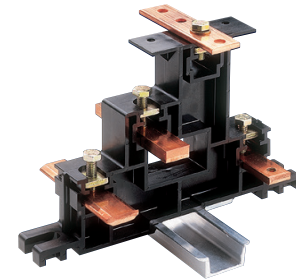

sb_038.eps

Characteristics

Support	L max. (support bars in mm) for							Iz (A) ⁽¹⁾
	peak I _{sc}	10 kA	15 kA	24 kA	38 kA	48 kA	63 kA	
	rms I _{sc}	6 kA	9 kA	12 kA	19 kA	23 kA	30 kA	
	Bar x qty							
Type 1	15 x 3 x 1	950	625	400	250	175		160
Type 1	15 x 5 x 1	1000	825	500	300	175		220
Type 1	15 x 6 x 1	1000	900	550	300	200		250
Type 1	15 x 8 x 1	1000	1000	650	300	200		290
Type 1	20 x 3 x 1	1000	825	525	300	175		210
Type 1	20 x 5 x 1	1000	1000	675	300	175		280
Type 1	20 x 6 x 1	1000	1000	750	300	175		310
Type 1	20 x 8 x 1	1000	1000	775	300	175		370
Type 1	32 x 5 x 1	1000	1000	675	250	170		410
Type 1	32 x 6 x 1	1000	1000	675	250	170		460
Type 2	15 x 3 x 1	950	625	400	250	200	150	160
Type 2	15 x 5 x 1	1000	825	500	325	250	175	220
Type 2	15 x 6 x 1	1000	900	550	350	275	200	250
Type 2	15 x 8 x 1	1000	1000	650	400	325	225	290
Type 2	20 x 3 x 1	1000	825	525	325	250	200	210
Type 2	20 x 5 x 1	1000	1000	675	425	325	225	280
Type 2	20 x 6 x 1	1000	1000	750	450	375	225	310
Type 2	20 x 8 x 1	1000	1000	850	525	375	225	370
Type 2	32 x 5 x 1	1000	1000	1000	525	325	175	410
Type 2	32 x 6 x 1	1000	1000	1000	525	325	175	460

(1) Admissible busbar nominal current with a temperature inside the panel of between 113°F and 176°F. For other mounting configurations, please contact us. **N.B.:** Iz indicated is for a solid (undrilled) busbar.

Dimensions

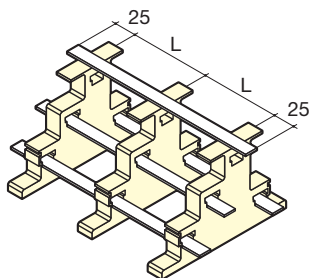

sb_041_b_1_x_caf

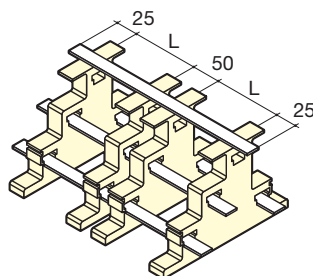

sb_047_a_1_x_caf

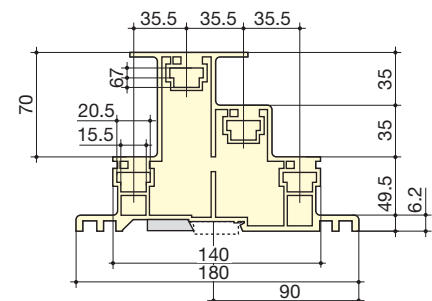

sb_038_e_1_x_caf

Type 1: Busbars including 3 (or more) equally spaced SB E 44 supports.

Type 2: Busbars with 3 (or more) SB E 44 supports with doubled intermediary supports.

Mounting with elliptical holes: 150 to 170 mm.

■ SB P 44 four pole flat mounting busbar support with fixed interphase, for mounting angled bars

References

No. of poles	Insulation voltage (VAC)	Bar width (mm)	Pack qty	Reference
4 P	1,000	20 -32	1	5026 0450

SB P 44: 1 bar of 5 or 10 mm thickness with a width of 20, 25, 30 or 32 mm.
Please note: protection cover not supplied.



sb_170.pdf

Characteristics

peak I_{sc}	L max. (support bars in mm) for							
	10 kA	15 kA	24 kA	48 kA	63 kA	82 kA		
rms I_{sc}	6 kA	9 kA	12 kA	23 kA	30 kA	39 kA		
Bar x qty							d min. (mm)	Iz (A)
20 x 5 x 1	1000	1000	800	350	200	125	50	280
25 x 5 x 1	1000	1000	1000	350	200	125	50	330
32 x 5 x 1	1000	1000	1000	350	200	120	50	390
25 x 10 x 1	1000	1000	1000	350	200	125	50	500
30 x 10 x 1	1000	1000	1000	350	200	120	50	580
32 x 10 x 1	1000	1000	1000	350	200	120	50	610

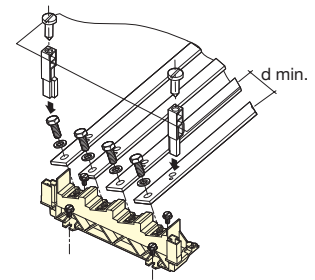

sb_165_c_1_x_caf

Dimensions

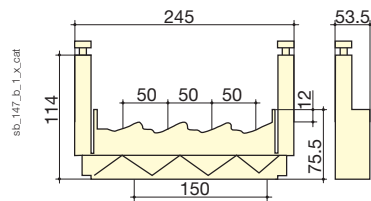

sb_147_b_1_x_caf



Enclosed disconnect solutions

Enclosed disconnect switches

Enclosed non-fusible disconnect switches, fusible switches & transfer switches



UL / NEMA 3R/12
Painted steel
p. 200



UL / NEMA 4, 4X
Fiberglass
p. 200



UL / NEMA 4, 4X
Stainless steel (304)
p. 200



**UL / NEMA 1, 3, 3R,
12, 4, 4X**
Polycarbonate
p. 200

Enclosed disconnect switches

Non-fusible disconnect switches, fusible disconnect switches & transfer switches up to 1200 A



UL / NEMA 1, 3, 3R, 12, 4, 4X
Polycarbonate
Ref. 2214 3503

conf-ul_008_1.eps



UL / NEMA 4, 4X
Fiberglass
Ref. US221E 3903

conf-ul_004.png



UL / NEMA 4, 4X
Stainless steel
Ref. US221X 3903

conf-ul_004_1.eps



UL / NEMA 3R, 12
Painted steel
Ref. US30VC 3003

conf-ul_002.png

The solution for

- > OEM/Machine Builders
- > Industrial Control Panels Manufacturers
- > Switchboard Manufacturers (UL 891)
- > Distributors



Strong points

Suitable for use as:

- > Manual motor controller
- > OSHA Lockout/Tagout disconnects
- > Safety switches
- > Emergency power electrical installations

Function

Enclosed disconnect switches range are used as:

- The NEC required motor disconnect upstream from the motor.
- Main disconnecting means, fusible and non-fusible.
- OSHA Lock Out / Tag Out devices to isolate a load for maintenance, service or repair.
- Transferring low voltage circuits on load.

Advantages

A flexible range

- Designed for normal as well as difficult or harsh environments (wash down, mechanical impacts, corrosion...).
- UL / NEMA rated enclosures up to 1, 3R, 12, 4, 4X.
- Metallic and nonmetallic enclosures.
- Compact design.
- For applications up to 1200 A.

High switching performance, simple wiring

- High short-circuit rating.
- Reliable switching technology.
- Large terminals.

Robust and ergonomic handle

- Red/Yellow handle (available in black).
- Painted steel enclosure are equipped with heavy duty handle with metallic padlock hasp.
- Clear On - Off positions indication.
- 3 padlocks capability.
- Door interlocking in ON position and padlocked in OFF position.
- Defeatable door interlock in ON position. (The interlocking is automatically reactivated when the door is closed, except for polycarbonate boxes up to 60A).

Conformity to standards

- > cULus 508A
- > UL 60947-4-1*
CSA-C22.2 No. 14
Guide NLRV
File E173959
- > UL 489
CSA-C22.2 No. 5
File E255272
- > UL 98
CSA-C22.2 No. 4
Guide WHTY
File E201138
- > UL 1008
Guide WPHYV
File E317092
- > CSA-C22.2 No. 4
Class 4651-02
File 112964
- > CSA-C22.2 No. 5
Class 4652-06
File 112964
- > CSA-C22.2 No. 14
Class 3211-05
File 112964



*replaces UL 508

Enclosed disconnect switches

Non-fusible disconnect switches, fusible disconnect switches and transfer switches
up to 1200 A

Applications and range overview



Heavy duty industry



site_824_a.eps



Food and beverage processing



site_712_a.eps



Machinery and safety



corpo_207_a.eps

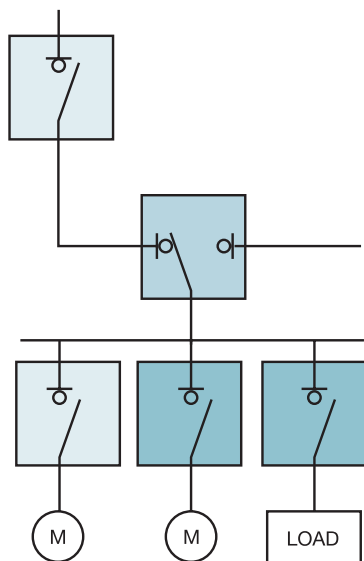

col_486_a.eps

	Rating (A)	Switch	Enclosure	UL / NEMA
Service Entrance Disconnect or Branch Disconnect	100 A non-fusible	SIRCO M (UL 98)	Polycarbonate	1, 3, 3R, 12, 4, 4X
	Up to 1200 A non-fusible	SIRCO (UL 98)	Fiberglass	4, 4X
	Up to 800 A fusible	FUSERBLOC (UL 98)	Stainless steel	4, 4X
Transfer switch	Up to 400 A non-fusible	SIRCOVER (UL 1008)	Painted steel	3R, 12
	Up to 1200 A non-fusible	SIRCOVER (UL 98)		
Manual motor Disconnect	Up to 60 A non-fusible	SIRCO M (UL 60947-4-1) ⁽¹⁾	Painted steel	3R, 12
			Polycarbonate	1, 3, 3R, 12, 4, 4X
			Fiberglass	4, 4X
			Stainless steel	4, 4X

(1) Meets the requirements of the standard UL 508.

Enclosed disconnect switches

Non-fusible disconnect switches, fusible disconnect switches and transfer switches
up to 1200 A

References

Non-fusible disconnect switch, suitable for use as motor disconnect and service entrance disconnect

UL / NEMA enclosure, 3-pole, 600 VAC, non-fusible

Approvals	Rating (A)	UL / NEMA 3R, 12 ⁽²⁾ Painted steel color ANSI 61 gray	UL / NEMA 1, 3R, 12, 4, 4X Fiberglass color RAL 7035 light-gray	UL / NEMA 1, 3R, 12, 4, 4X Stainless steel (304) brushed finish	UL / NEMA 1, 3, 3R, 12, 4, 4X Polycarbonate color RAL 7035 light-gray
cULus 60947-4-1	30 ⁽¹⁾	US221M 3703	US221E 3903	US221X 3903	2214 3503
	60 ⁽¹⁾	US222M 3706	US222E 3906	US222X 3906	2224 3506
cULus 508A	100	US30UC 3010	US30UL 3010	US30UF 3010	30UJ 3010
	200	US30UC 3020	-	-	-
	400	US30UC 3040	-	-	-
	600	US30UC 3060	-	-	-
	800	US30UC 3080	-	-	-
	1200	US30UC 3120	-	-	-

(1) Suitable for motor disconnect.

(2) Handle with metallic padlocking hasp.

(3) UL 98.

(4) 30 A in large 60 A enclosure.

Accessories sold separately

Rating (A)	Auxiliary contacts	Unswitched neutral pole	Switched fourth pole	Terminal shrouds / screens	
				3 P	1 P
30	1 AC NO + NC 2299 0001 ⁽⁶⁾	2200 5005	2200 1003	2294 3005 ⁽²⁾	2294 1005 ⁽²⁾
60		2200 5009	2200 1006 ⁽¹⁾	2294 3009 ⁽²⁾	2294 1009 ⁽²⁾
100	1 AC 2 NC 2299 0011 ⁽⁶⁾	2200 5011	2200 1010	2294 3016 ⁽²⁾	2294 1011 ⁽²⁾
200		30AC 0102 ⁽⁷⁾		2798 3021 ⁽³⁾	2798 8021 ⁽⁴⁾
400	1 st AC NO + NC 2799 0021	30AC 0104 ⁽⁷⁾		2798 3041 ⁽³⁾	2798 8041 ⁽⁴⁾
600	2 nd AC NO + NC 2799 0022	30AC 0106 ⁽⁷⁾		2798 3060 ⁽⁵⁾	
800		30AC 0108 ⁽⁷⁾			
1200				2798 3120 ⁽⁵⁾	

(1) Not UL.

(2) Top or bottom.

(3) Top.

(4) Bottom.

(5) Load side screen, the line side is included with the switch.

(6) Not UL only for rating 100 A.

(7) UL components

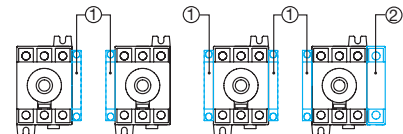

Configuration of the auxiliary contacts for enclosed SIRCO M.

1. M type auxiliary contacts.

2. Additional pole.

sircm-ul_012_a_1_x_cat.eps

Enclosed disconnect switches

Non-fusible disconnect switches, fusible disconnect switches and transfer switches
up to 1200 A

Fusible disconnect switch, fuse class CC, J and L suitable for use as motor disconnect and service entrance disconnect

UL / NEMA enclosure, 3-pole, 600 VAC, fusible⁽¹⁾

Accessories sold separately

			
Approvals	Rating (A)	Fuse type	UL / NEMA 3R, 12 ⁽²⁾ Painted Steel color ANSI 61 gray
cULus 508A	30	J	US30VC 3A03
	30		US30VC 3003
	60		US30VC 3006
	100		US30VC 3010
	200		US30VC 3020
	400		US30VC 3040
	600	US30VC 3060	
	800	L	US30VC 3080

			
Unswitched neutral pole	Class T fuses adapter	U-type auxiliary contacts	Terminal shrouds / screens
-	-	1 AC NO 3999 0701 1 AC NC 3999 0702	As standard
-	-		
-	-		
30AC 0102	3729 8010		3898 3020 ⁽³⁾ 3898 3040 ⁽³⁾ 3898 3080 ⁽⁴⁾
30AC 0104	3729 8020		
30AC 0106	3729 8040		
30AC 0108	3729 8060		
30AC 0108	3729 8080		

(1) Fuses not included.

(2) Handle with metallic padlocking hasp.

(3) Top or bottom.

(4) Load side screen, the line side is included with the switch.

Transfer switch

UL / NEMA enclosure, 3-4 poles, 600 V, non-fusible

Accessories sold separately

			
Approvals	Rating (A)	UL / NEMA 3R, 12 ⁽¹⁾ Painted Steel color ANSI 61 gray	
		3 P	4 P
UL 1008	100	US30WC 3010	US30WC 4010
	200	US30WC 3020	US30WC 4020
	400	US30WC 3040	US30WC 4040
cULus 508A	600	US30WC 3060	US30WC 4060
	800	US30WC 3080	US30WC 4080
	1200	US30WC 3120	US30WC 4120

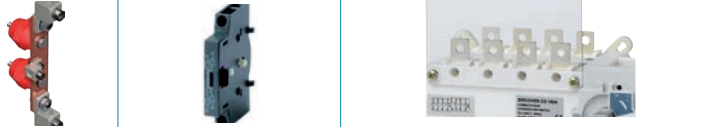
			
Unswitched neutral pole	Auxiliary contacts	Terminal screens	
		3 P	4 P
30AC 0102	1 AC NO/NC on position 1 and 2 4159 0021	4158 3021	4158 4021
30AC 0104		4158 3041	4158 4041
30AC 0106	NO/NC on position 1 and 2 As standard	1609 3063	1609 4063
30AC 0108		1609 3080	1609 4080
30AC 0112			

(1) Handle with metallic padlocking hasp.

Enclosed disconnect switches

Non-fusible disconnect switches, fusible disconnect switches and transfer switches
up to 1200 A

Characteristics

Non-fusible disconnect switch - Characteristics according to UL 60947-4-1, UL 98 and CSA-C22.2 No. 4 and No. 14

General use rating (A)	Motor disconnect		Service disconnect, non-fusible					
	30	60	100	200	400	600	800	1200
Short circuit at 600 VAC (kA)	65	50/65	25 (100)	200	200	200	100	100
Type of fuse	J	J	J	J	J	J	L	L
Max rating (A)	30	100/60	100	200	400	600	800	1200
Max. motor hp / FLA 3 ph motor max.								
208 VAC	7.5 / 24.2	15 / 46.2	-	-	-	-	-	-
220-240 VAC	7.5 / 22	20 / 54	20 / 54	75 / 192	125 / 312	200 / 480	200 / 480	200 / 480
440-480 VAC	20 / 27	40 / 52	50 / 65	150 / 180	250 / 302	400 / 477	500 / 590	500 / 590
600 VAC	25 / 27	40 / 41	50 / 52	200 / 192	350 / 336	350 / 336	500 / 472	500 / 472
Connection terminals								
Min. connection section / AWG	#14 - #14	#14 - #1	#12 - #10	#6 - 300MCM	#2 - 600MCM	#2 - 600MCM	#2 - 600MCM	#2 - 600MCM
Max. connection section / AWG	2x (#14 - #12)	2x (#10 - #6)	-	-	2x (#6-350MCM)	2x (#2-600MCM)	4x (#2-600MCM)	4x (#2-600MCM)
Mechanical characteristics								
Endurance (number of cycles)	10 000	10 000	10 000	8 000	6 000	6 000	3 500	3 500
Operating torque (lbs.in/Nm)	7 / 0.8	8.9 / 1	12.4 / 1.4	88.5 / 10	128.3 / 14.5	327.5 / 37	442.5 / 50	442.5 / 50
Auxiliary contacts								
Electrical characteristics	A300	A300	A300	A300	A300	A600	A600	A600

Fusible disconnect switch - Characteristics according to UL 489, UL 98 and CSA-C22.2 No. 4

General use rating (A)	30 ⁽¹⁾	30	60	100	200	400	600	800
Short circuit at 600 VAC (kA)	100	100	200	200	200	200	200	200
Type of fuse	CC	J	J	J	J	J	J	L
Max rating (A)	30	30	60	100	200	400	600	800
Max. motor hp / FLA 3 ph motor max.								
220-240 VAC	7.5 / 22	7.5 / 22	15 / 42	30 / 80	60 / 154	125 / 312	200 / 480	200 / 480
440-480 VAC	15 / 21	15 / 21	30 / 40	60 / 77	125 / 156	250 / 302	500 / 590	500 / 590
600 VAC	20 / 22	20 / 22	50 / 52	75 / 77	150 / 144	350 / 336	500 / 472	500 / 472
Connection terminals								
Min. connection section / AWG	#14 - #10	#14 - #10	#10 - #6	#10 - 2/0	#6 - 300MCM	#2 - 600MCM	#2 - 600MCM	#2 - 600MCM
Max. connection section / AWG	-	-	-	-	-	2x (#6-350MCM)	2x (#2-600MCM)	2x (#2-600MCM)
Mechanical characteristics								
Endurance (number of cycles)	10 000	10 000	10 000	10 000	8 000	6 000	5 000	5 000
Operating torque (lbs.in/Nm)	31 / 3.5	31 / 3.5	71 / 8	71 / 8	90 / 10.2	150 / 17	586 / 66.2	586 / 66.2
Auxiliary contacts								
Electrical characteristics	A600	A600	A600	A600	A600	A600	A600	A600

(1) UL 489.

Enclosed disconnect switches

Non-fusible disconnect switches, fusible disconnect switches and transfer switches
up to 1200 A

Transfer switch - Characteristics according to UL 98, UL 1008 and CSA-C22.2 No. 4

General use rating (A)	100 A	200 A	260 A	400 A	600 A	800 A	1200 A
Frame size	B4		B5		B6	B7	
Operation voltage 2 P - 3/4 P	240/600	240/600	240/600	240/600	-/600	-/600	-/600
Short circuit rating at 600 VAC with fuses (kA)							
Short circuit rating at 600 VAC (kA)	100	100	65	65	200	100	100
Type of fuse	J	J	J	J	J	L	L
Max fuse rating (A)	200	400	600	600	600	800	1200
Short circuit rating at 600 VAC with "Specific Circuit Breaker" (kA)							
Square D JJ breaker 250 A - 2 P 240 VAC - 3/4 P 480 VAC	65	65	-	-	-	-	-
Schneider Electric NSX-F 160 A - 3/4 P 480 VAC	35	-	-	-	-	-	-
Short circuit rating at 600 VAC with "Any Breaker" (kA)							
Short circuit rating (kA)	10	10	14	14	35	35	35
Short circuit capacity (ms)	25	25	50	50	50	50	50
Rated operational current							
240 VAC "Total System" (A)	100	200	260	400	480	-	-
240 VAC resistive load (A)	100	200	260	400	480	-	-
480 VAC "Total System" (A)	100	100	260	400	477	-	-
480 VAC resistive load (A)	100	200	260	400	477	-	-
600 VAC "Total System" (A)	100	100	200	200	500	-	-
600 VAC resistive load (A)	100	200	260	400	500	-	-
Mechanical endurance							
Endurance (number of operating cycles)	6050	6050	6050	4050	5000	3500	2500
Connection terminals							
Min. connection section / AWG	#6	#6	#4 / 2 X 1 / 0	#4 / 2 X 1 / 0	-	-	-
Max. connection section / AWG	300MCM	300MCM	600MCM / 2 X 250MCM	600MCM / 2 X 250MCM	-	-	-

Enclosed disconnect switches

Non-fusible disconnect switches, fusible disconnect switches and transfer switches
up to 1200 A

Dimensions (in/mm)

UL / NEMA enclosure 1, 3, 3R, 12, 4, 4X - polycarbonate

Non-fusible disconnect switch up to 100 A

Rating (A)	Unit	H	W	D	G	F	Y	Z	Weight (lbs)
0 ... 30	in	5.9	3.9	3.62	0	6	4.37	6.38	4.4
	mm	150	99	92	0	152.5	111	162	
0 ... 60	in	7.8	4.94	3.62	4.45	7.32	4.37	8.27	6.6
	mm	198	125.5	92	113	186	111	210	
0 ... 100	in	11.81	8.27	5.35	7.44	9.37	7.12	11.81	9
	mm	300	210	136	189	238	181	300	

Note: dimensions subject to change based on enclosure manufacturer availability.

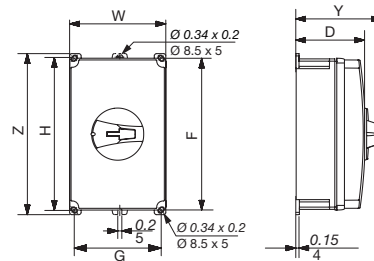

conf_491_a.eps

UL / NEMA enclosure 1, 3, 3R, 12, 4, 4X - fiberglass

Non-fusible disconnect switch up to 100 A

Rating (A)	Unit	H	W	D	G	F	X	Y	Z	Weight (lbs)
0 ... 30	in	7.12	7.24	5.27	4.56	7.36	7.99	6.97	8.15	4.4
	mm	181	184	134	116	187	203	177	207	
0 ... 60	in	9.13	7.24	5.27	4.56	9.37	7.99	6.97	10.16	6.6
	mm	232	184	134	116	238	203	177	258	
0 ... 100	in	12.08	11.23	7.28	8.56	13.34	12.05	8.97	14.08	11
	mm	307	285	185	217	339	306	228	358	

Note: dimensions subject to change based on enclosure manufacturer availability.

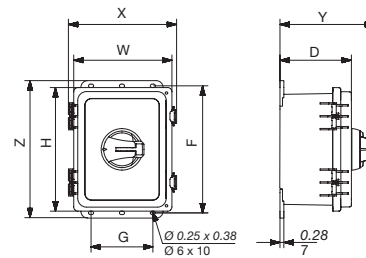

conf_497_a.eps

UL / NEMA enclosure 1, 3, 3R, 12, 4, 4X - stainless steel (grade 304)

Non-fusible disconnect switch up to 100 A

Rating (A)	Unit	H	W	D	G	F	X	Y	Z	Weight (lbs)
0 ... 30	in	6.29	6.26	4.84	4	6.75	6.97	6.38	7.50	4.4
	mm	159	159	123	102	171	177	162	191	
0 ... 60	in	8.26	6.26	4.84	4	8.75	6.97	6.38	9.50	6.6
	mm	210	159	123	102	222	177	162	241	
0 ... 100	in	12	10	6	8	12.75	11	8.4	13.5	12
	mm	305	254	152	203	324	280	213	343	

Note: dimensions subject to change based on enclosure manufacturer availability.

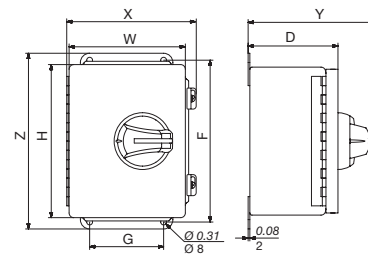

conf_499_a.eps

UL / NEMA enclosure 1, 3R, 12, - painted steel

Non-fusible disconnect switch up to 100 A

Rating (A)	Unit	H	W	D	G	F	X	Y	Z	Weight (lbs)
0 ... 30	in	6.0	6.0	4.8	4.0	6.8	6.9	6.6	7.5	6
	mm	152.4	152.4	120.7	101.6	171.5	176.3	167.6	190.5	
0 ... 60	in	8.0	6.0	4.8	4.0	8.8	6.9	6.6	9.5	7
	mm	203.2	152.4	120.7	101.6	222.3	176.3	167.6	241.3	
0 ... 100	in	12.0	10.0	6.8	8.0	12.8	10.9	8.6	13.5	16
	mm	304.8	254.0	171.5	203.2	323.9	277.9	218.4	342.9	

Fusible disconnect switch up to 100 A

Rating (A)	Unit	H	W	D	G	F	X	Y	Z	Weight (lbs)
0 ... 30	in	10.0	8.0	6.8	6.0	10.8	8.9	8.8	11.5	11
	mm	254.0	203.2	171.5	152.4	273.1	227.1	223.5	292.1	
0 ... 60	in	12.0	10.0	8.8	8.0	12.8	10.9	10.4	13.5	18
	mm	304.8	254.0	222.3	203.2	323.9	277.9	264.2	342.9	
0 ... 100	in	14.0	12.0	8.8	10.0	14.8	12.9	10.4	15.5	24
	mm	355.6	304.8	222.3	254.0	374.7	328.7	264.2	393.7	

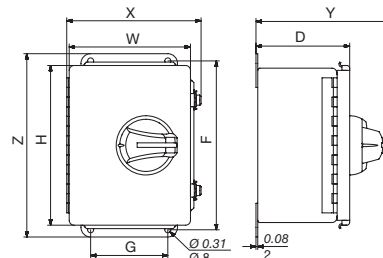

conf_498_a.eps

Enclosed disconnect switches

Non-fusible disconnect switches, fusible disconnect switches and transfer switches
up to 1200 A

UL / NEMA enclosure 1, 3R, 12, - painted steel

Non-fusible disconnect switch > 100 A

Rating (A)	Unit	H	W	D	G	F	X	Y	Z	Weight (lbs)
200	in	24.0	16.0	6.8	14.0	24.8	16.9	8.6	25.5	80
	mm	609.6	406.4	171.5	355.6	628.7	430.3	218.4	647.7	
400	in	30.0	20.0	10.8	18.0	30.8	20.9	12.6	31.5	115
	mm	762.0	508.0	273.1	457.2	781.1	531.9	320.0	800.1	
600	in	42.0	24.0	12.8	22.0	42.8	24.9	15.3	43.5	230
	mm	1066.8	609.6	323.9	558.8	1085.9	633.5	387.9	1104.9	
800 ... 1200	in	60.0	36.0	12.8	34.0	60.8	36.9	15.3	61.5	332
	mm	1524.0	914.4	323.9	863.6	1543.1	938.3	387.9	1562.1	

Fusible disconnect switch > 100 A

Rating (A)	Unit	H	W	D	G	F		Y	Z	Weight (lbs)
200 A	in	24.0	20.0	10.8	18.0	24.8	20.9	12.6	25.5	92
	mm	609.6	508.0	273.1	457.2	628.7	531.9	320.0	647.7	
400 A	in	42.0	32.0	12.8	30.0	42.8	32.9	14.6	43.5	200
	mm	1066.8	812.8	323.9	762.0	1085.9	836.7	370.8	1104.9	
600 A	in	48.0	36.0	12.8	34.0	48.8	36.9	15.3	49.5	268
	mm	1219.2	914.4	323.9	863.6	1238.3	938.3	387.9	1257.3	
800 A	in	60.0	36.0	12.8	34.0	60.8	36.9	15.3	61.5	332
	mm	1524.0	914.4	323.9	863.6	1543.1	938.3	387.9	1562.1	

Transfer switch ≥ 100 A

Rating (A)	Unit	H	W	D	G	F		Y	Z	Weight (lbs)
100 ... 200	in	24.0	20.0	10.8	18.0	24.8	20.9	12.6	25.5	95
	mm	609.6	508.0	273.1	457.2	628.7	531.9	320.0	647.7	
400	in	30.0	24.0	16.8	22.0	30.8	24.9	19.3	31.5	185
	mm	762.0	609.6	425.5	558.8	781.1	633.5	489.5	800.1	
600	in	48.0	36.0	20.8	34.0	48.8	36.9	23.3	49.5	321
	mm	1219.2	914.4	527.1	863.6	1238.3	938.3	591.1	1257.3	
800 ... 1200	in	60.0	36.0	20.8	34.0	60.8	36.9	23.3	61.5	460
	mm	1524.0	914.4	527.1	863.6	1543.1	938.3	591.1	1562.1	

Note: dimensions are subject to change. Please consult us for verification.

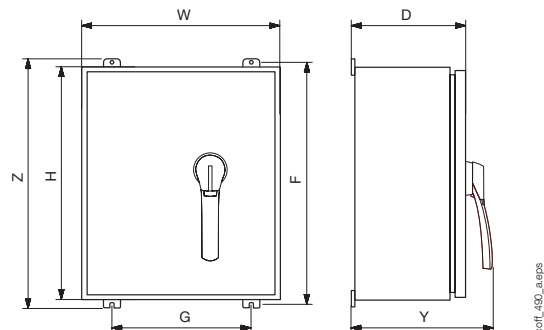



Metering, monitoring & power quality

Integrated Choosing the right power meter
 Power Monitoring Architecture p. 210
 Selection guide - Multi-point Power Metering & Monitoring p. 214
 Selection guide - Single-point Power Metering & Monitoring p. 226
 Selection guide - Enclosed Power Metering & Monitoring p. 232

Multi-point Power Metering & Monitoring

DIRIS Digiware AC



DIRIS Digiware D, M, and C31
p. 240



DIRIS Digiware U
p. 256



DIRIS Digiware S
p. 258



DIRIS Digiware BCM
p. 262



DIRIS Digiware I
p. 268

DIRIS Digiware DC



DIRIS Digiware IO
p. 274



DIRIS Digiware Udc
p. 276



DIRIS Digiware Idc
p. 280

Single-point Power Metering & Monitoring



DIRIS A-100/A-200
p. 284



DIRIS A-40
p. 294



DIRIS B
p. 300



DIRIS A-30
p. 308



DIRIS A-20
p. 312



DIRIS A-10
p. 316

Enclosed Power Metering & Monitoring



DIRIS DigiBOX A, B, M
p. 320



DIRIS MCM
p. 338



RF END-Node & HUB-Node
p. 344

Current sensors



AC current sensors
p. 348



DC current sensors
p. 356



Accu-CT current sensors
p. 360



TR-W sensors
p. 362



Rogowski Coil current sensors
p. 364

Software suite

WEBVIEW
Embedded web server
p. 368



Choosing the right power meter!

Socomec offers a wide range of power meters serving a variety of applications and market segments.

Power meters are available in different shapes, form factors and functionality levels to address each application's requirements. This is why selecting the right power meter typically requires details about your application and the expected integration.

The below flowchart aims at simplifying the selection process, guiding you towards the right solution through basic questions, but many additional questions can be asked to make this selection even more accurate:

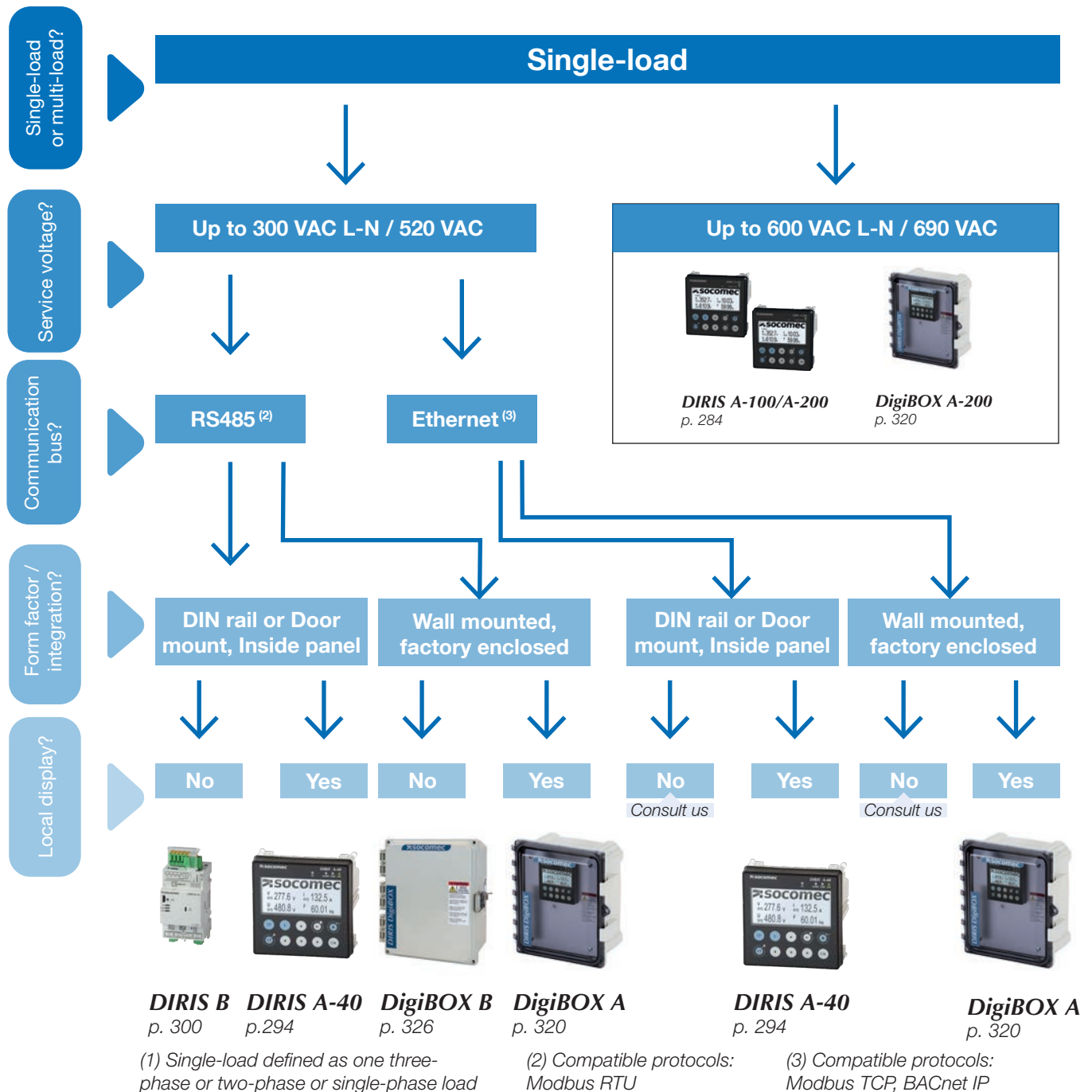

Typical questions

Where is the meter going

Does the meter need to communicate measurements to a 3rd party system?
What is the preferred communication

Do you need a local display?

How many circuits need to be monitored?
Are all circuits under the same voltage source?

What measurement

Is a web interface needed to visualize measurements?

Multi-load ⁽⁴⁾

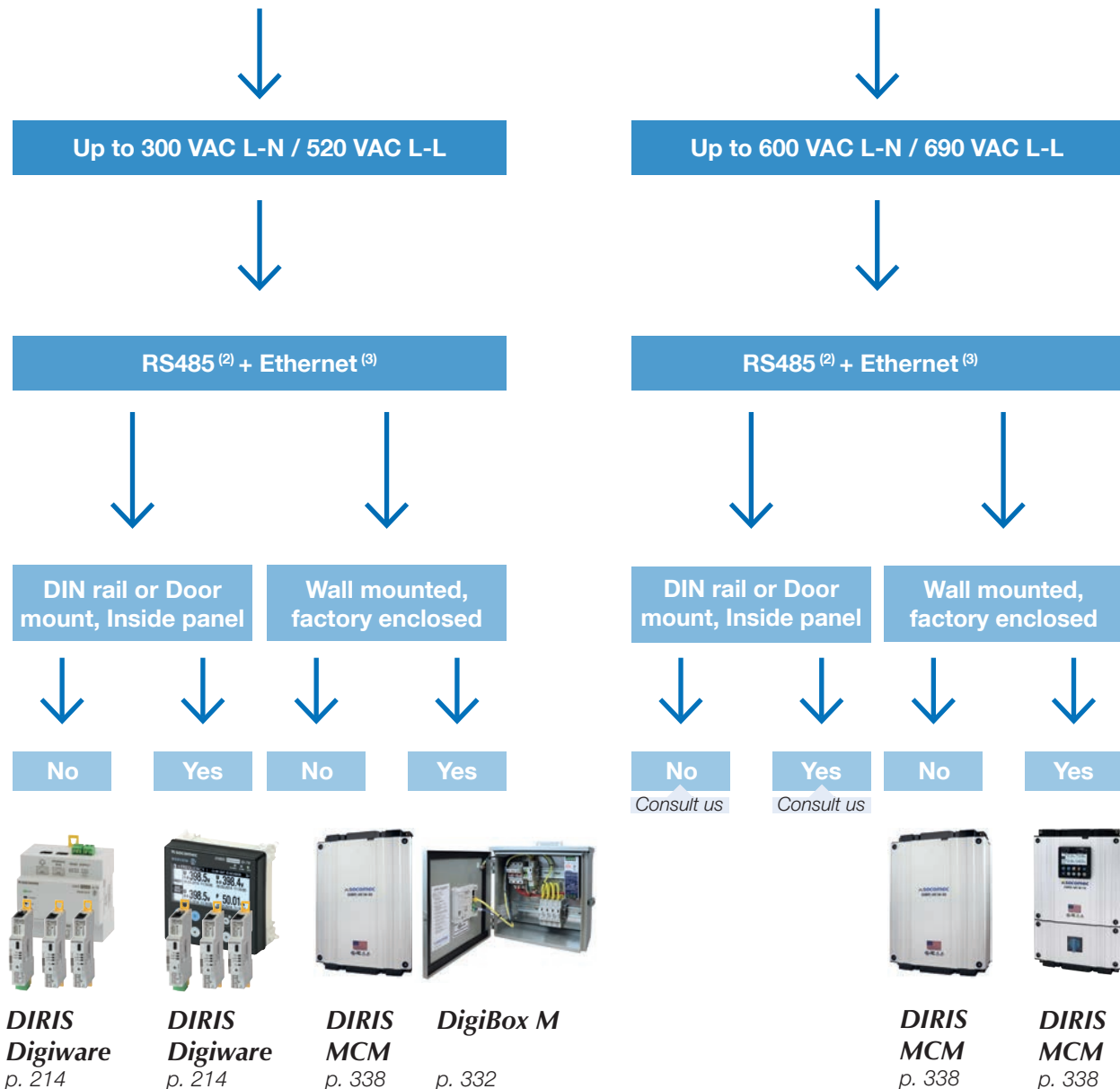

(4) Multi-load defined as multiple three-phase or two-phase or single-phase loads sharing the same voltage source

Power Monitoring Architecture

Example

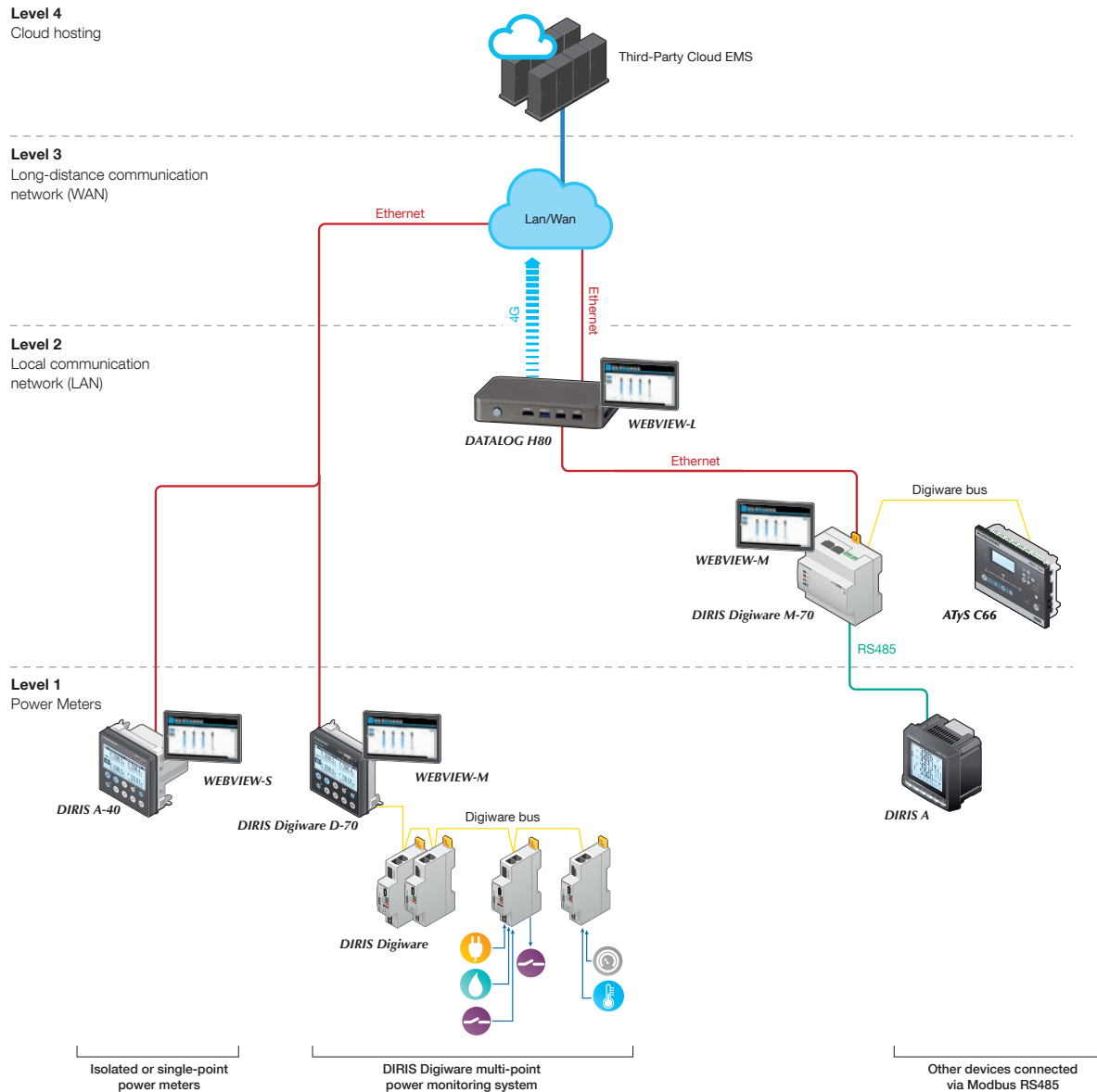

scell_090_b_1US

Expert Services

Our service engineers are an essential part of our team, and they are dedicated to ensuring your power monitoring system provides accurate and reliable measurements to your EPMS software or SCADA system.

Our services include:

- > Site audits to verify the proper wiring of your system
- > Personnel training on how to configure, operate and maintain power monitoring equipment and associated software
- > Remote and on-site commissioning to ensure that your system is up and running quickly, with peace of mind.

For further information, please contact your nearest SOCOMEC branch.



References

1/2 day remote commissioning	Remote commissioning including installation verification, programming and communication testing	923 010 0027
1/2 day on-site commissioning	On-site commissioning including installation verification, programming and communication testing	923 010 0004

Multi-point Power Metering & Monitoring

DIRIS Digiware AC & DC



Flexible

A modular concept allowing you to customize your own system to monitor any number of circuits within switchboards, panelboards, motor control centers etc



Versatile

More than just energy metering, the system monitors power quality, breaker status & trips, collects pulses from gas/water meters and reads analog 0/4-20 mA signals.



Web interface

Access real time and historical measurements remotely thanks to a free built-in web interface on all Ethernet based power meters.



Multi-circuit

Monitor up to 64 three-phase circuits in one system. With shared communication, power supply, and voltage module, installation time costs and space are significantly reduced.



PreciSense technology

Unrivalled class 0.5 system accuracy (including current sensors), exceeding revenue grade requirements and ensuring reliable measurements under all conditions.

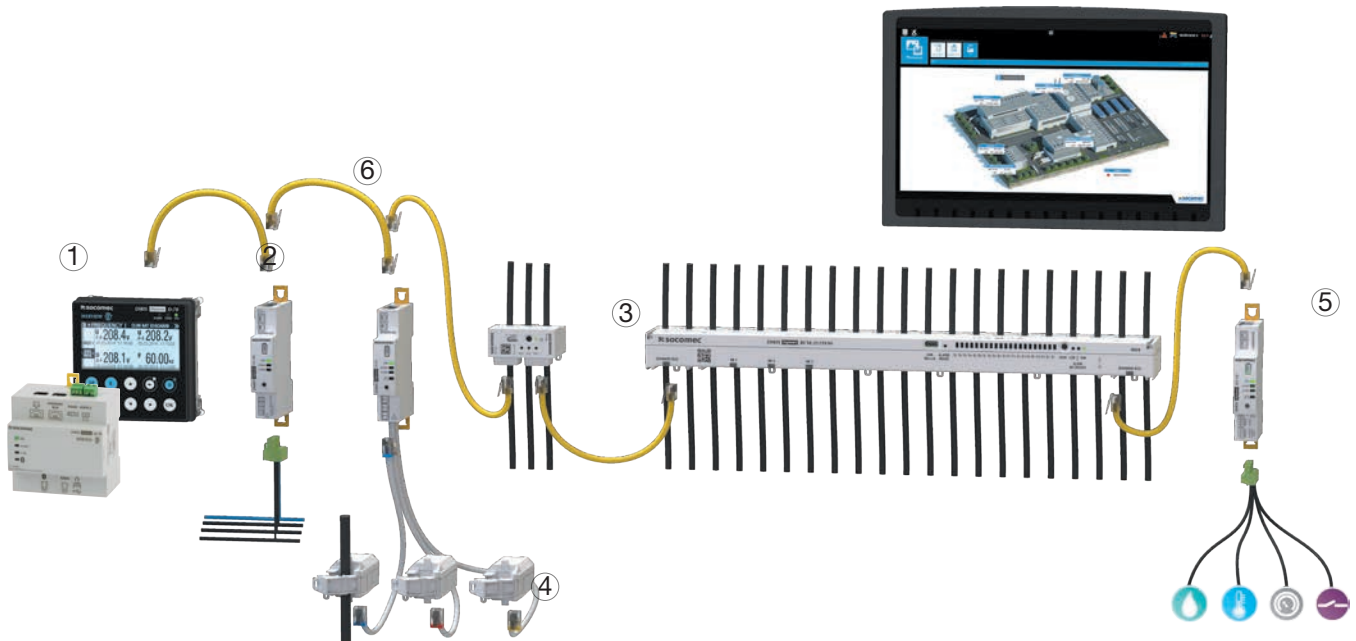

Selection Guide

Multi-point Power Metering & Monitoring

DIRIS Digiware AC & DC

Choose your communication interface

1



DIRIS Digiware D display

or



DIRIS Digiware M gateway

or



DIRIS Digiware C-31 interface

Choose your voltage acquisition module

2



DIRIS Digiware Uac
AC voltage module



DIRIS Digiware Udc
DC voltage module

Choose your current acquisition module

3



DIRIS Digiware S
AC current module with (3)
integrated current sensors



DIRIS Digiware BCM
AC current module with (21)
integrated current sensors

NEW



DIRIS Digiware Iac
AC current module



DIRIS Digiware Idc
DC current module

Choose your AC current sensors

For **DIRIS DIGIWARE Iac** current modules

4



RJ12 technology
Solid-core, split-core, flexible Rogowski



RJ12 cables

or

4

Choose your DC current sensors

For **DIRIS DIGIWARE Idc** current modules



DC current sensors



RJ12 cables

Choose your optional input/output module

5



DIRIS Digiware IO-10
4 digital inputs / 2 digital outputs



DIRIS Digiware IO-20
2 analog inputs

6



To interconnect Digiware
D/M/C/U/I/S/BCM/IO







Create your project
www.meter-selector.com



METER SELECTOR
DIGITAL TOOL AVAILABLE



1

Communication interface







	Centralization and display of data				Data centralization	Repeater
						
	M-50	M-70	D-50	D-70	C-31	C-32
DIRIS Digiware						
Main function						
Centralization of measurements	•	•	•	•	•	-
LCD High-resolution display	-	-	•	•	-	-
Bus Repeater	-	-	-	-	-	•
Power supply						
24 VDC	•	•	•	•	•	•
Communication						
Digiware bus	•	•	•	•	•	•
RS485	Modbus RTU Slave / Master	Modbus RTU Slave / Master	Modbus RTU Slave / Master	Modbus RTU Slave / Master	Modbus RTU Slave	-
Ethernet	Modbus TCP BACnet IP SNMP	Modbus TCP BACnet IP SNMP	Modbus TCP BACnet IP SNMP	Modbus TCP BACnet IP SNMP	-	-
Embedded web server	WEB-CONFIG	WEBVIEW-M	WEB-CONFIG	WEBVIEW-M	-	-
Reference	4829 0221	4829 0222	4829 0204	4829 0203	4829 0101	4829 0103

2

AC voltage acquisition module

	U-10	U-30
		 500 VAC COMING SOON
DIRIS Digiware		
Electrical		
Voltage Measurement	50 - 300 VAC L-N 87 - 520 VAC L-L	50 - 300 VAC L-N 87 - 520 VAC L-L
Multi-measurement		
U12, U23, U31, V1, V2, V3, f	•	•
U system, V system	-	•
Unbalance U, V	-	•
Power Quality		
THD U, V	-	•
Individual Harmonics U, V (up to 63rd)	-	•
PQ Events (sags, swells, interruptions)	-	•
Waveform capture	-	-
Alarms		
Measurement thresholds	-	•
System alarms	•	•
History		
Average values	-	•
Reference	4829 0105	4829 0102

3 AC current modules with integrated current sensors







	S-130	S-135	BCM-2119	BCM-2119VM	BCM-2125	BCM-2125VM
DIRIS Digiware						
Format						
Number of integrated sensors	3	3	21	21	21	21
Maximum current for integrated sensors	63 A	63 A	80 A	80 A	120 A	120 A
Number of external RJ12 sensor inputs (allows to connect TE, TR/ITR, TF sensors)	-	-	3	3	3	3
Breaker pitch / center spacing	18 mm	18 mm	19 mm	19 mm	25 mm	25 mm
Metering						
± kWh, ± kvarh, kVAh	•	•	•	•	•	•
ΣP (kW), ΣQ (kvar), ΣS (kVA), PF	•	•	•	•	•	•
P (kW), Q (kvar), S (kVA), PF per phase	-	•	•	•	•	•
Predictive Power	-	•	•	•	•	•
Load curves / demand profiles	-	•	•	•	•	•
Peak Demand	-	•	•	•	•	•
Multi-tariff (max 8)	•	•	•	•	•	•
Multi-measurement						
I1, I2, I3, In	•	•	•	•	•	•
I system	-	•	•	•	•	•
Current unbalance (Inba, Idir, linv, lhom, Inb)	-	•	•	•	•	•
Phi, cos Phi, tan Phi	•	•	•	•	•	•
Power Quality						
THD I1, I2, I3, In, Isys	-	•	•	•	•	•
Individual harmonics I (up to 63rd)	-	•	•	•	•	•
Crest Factor I1, I2, I3, In	-	•	•	•	•	•
K-Factor	-	•	•	•	•	•
Ground leakage current monitoring	-	-	•	•	•	•
Alarms						
Overcurrents	-	•	•	•	•	•
Measurement thresholds	-	•	•	•	•	•
System alarms	•	•	•	•	•	•
Protective device	•	•	-	•	-	•
History						
Average values	-	•	•	•	•	•
Reference	4829 0160	4829 0161	4829 0167	4829 0168	4829 0169	4829 0170

Accessories

Description	Reference
DIN rail mounting clip for Digiware S (QTY 10)	4829 0195







3

AC current acquisition modules





	I-30	I-31	I-35	I-43	I-45	I-60	I-61
DIRIS Digiware							
General							
Number of current inputs	3	3	3	4	4	6	6
Inputs / Outputs							
Digital inputs / outputs	-	-	-	2 / 2	2 / 2	-	-
Metering							
± kWh, ± kvarh, kVAh	•	•	•	•	•	•	•
ΣP (kW), ΣQ (kvar), ΣS (kVA), PF	•	•	•	•	•	•	•
P (kW), Q (kvar), S (kVA), PF per phase	-	•	•	•	•	-	•
Predictive Power	-	-	•	-	•	-	-
Load curves / demand profiles	-	•	•	-	•	-	•
Peak Demand	-	-	•	•	•	-	-
Multi-tariff	-	-	8	-	8	-	-
Multi-measurement							
I1, I2, I3, In	•	•	•	•	•	•	•
I system	-	-	•	-	•	-	-
Current unbalance (Inba, Idir, linv, lhom, Inb)	-	-	•	-	•	-	-
Phi, cos Phi, tan Phi	-	-	•	-	•	-	-
Power Quality							
THD I1, I2, I3, In	-	-	•	•	•	-	-
Individual harmonics I (up to 63rd)	-	-	•	-	•	-	-
Crest Factor I1, I2, I3, In	-	-	•	-	•	-	-
K-Factor	-	-	•	-	•	-	-
Alarms							
Overcurrents	-	-	•	-	•	-	-
Measurement thresholds	-	Power / Energies	•	-	•	-	Power / Energies
System alarms	•	•	•	•	•	•	•
Protective device	•	•	•	•	•	•	•
	with ITR sensors	with ITR sensors	with ITR sensors	with ITR sensors	with ITR sensors	with ITR sensors	with ITR sensors
Logical (digital input status)	-	-	-	•	•	-	-
History							
Average values	-	-	•	-	•	-	-
Reference	4829 0110	4829 0111	4829 0130	4829 0129	4829 0131	4829 0112	4829 0113

4 RJ12 AC current sensors







Suitable for new installations
match the pitch of protective
devices

	Solid-core current sensors						
							
	TE-18	TE-25	TE-35	TE-45	TE-55	TE-55	TE-90
Nominal current In (A)	5 ... 20	25 ... 63	40 ... 160	63 ... 250	160 ... 630	400 ... 1000	600 ... 2000
Real range covered (A)	0.1 ... 24	0.5 ... 75.6	0.8 ... 192	1.26 ... 300	3.2 ... 756	8 ... 1200	12 ... 2400
Window (in/mm)	Ø 0.33 / 8.4	Ø 0.33 / 8.4	0.53 x 0.53 13.5 x 13.5	0.82 x 0.82 21 x 21	1.22 x 1.22 31 x 31	1.61 x 1.61 41 x 41	2.52 x 2.52 64 x 64
Connection	RJ12	RJ12	RJ12	RJ12	RJ12	RJ12	RJ12
Reference	4829 0500	4829 0501	4829 0502	4829 0503	4829 0504	4829 0505	4829 0506

Suitable for existing installations

	Split-core current sensors			
				
	TR/iTR-10	TR/iTR-14	TR/iTR-21	TR/iTR-32
Nominal current In (A)	25 ... 63	40 ... 160	63 ... 250	160 ... 600
Real range covered (A)	0.5 ... 75	0.8 ... 192	1.26 ... 300	3.2 ... 720
Window (in/mm)	Ø 0.39 / 10	Ø 0.55 / 14	Ø 0.83 / 21	Ø 1.26 / 32
Connection	RJ12	RJ12	RJ12	RJ12
Reference	4829 0555 / 4829 0655	4829 0556 / 4829 0656	4829 0557 / 4829 0657	4829 0558 / 4829 0658

Suitable for existing installations
with space constraints or
with high currents

	Flexible current sensors					
						
	TF-40	TF-80	TF-120	TF-200	TF-300	TF-600
Nominal current In (A)	100...400	150...600	400...2000	600...4000	1600...6000	1600...6000
Real range covered (A)	2...480	3...720	8...2400	12...4800	32...7200	32...7200
Window (in/mm)	Ø 1.57 / 40	Ø 3.15 / 80	Ø 4.72 / 120	Ø 7.87 / 200	Ø 11.81 / 300	Ø 23.62 / 600
Connection	RJ12	RJ12	RJ12	RJ12	RJ12	RJ12
Reference	4829 0573	4829 0574	4829 0575	4829 0576	4829 0577	4829 0578

TF sensors come with a 2m / 6.5 ft RJ12 lead which can be extended via use of female/female RJ12 connector (ref. 4829 0670).



4 RJ12 cables for TE / TR / iTR / TF AC current sensors

RJ12 connection cables	Cable length (ft/m)										
	0.32/0.1	0.64/0.2	0.96/0.3	1.64/0.5	3.3/1	6.5/2	9.84/3	16.4/5	23/7	32.8/10	164/50 + 100 connectors
Number of cables	Reference	Reference	Reference	Reference	Reference	Reference	Reference	Reference	Reference	Reference	Reference
1	-	-	-	-	-	-	-	4829 0602	-	4829 0603	4829 0601
3	4829 0580	4829 0581	4829 0582	4829 0595	4829 0583	4829 0584	4829 0606	4829 0607	4829 0608	4829 0609	-
4	-	-	-	4829 0596	4829 0588	4829 0589	-	-	-	-	-
6	4829 0590	4829 0591	4829 0592	4829 0597	4829 0593	4829 0594	-	-	-	-	-



Accessories

Description	Reference
RJ12 female/female connector (QTY 3)	4829 0670
1A / 5A CT Adaptor with RJ12 output	4829 0599

2 Direct voltage acquisition module



	<i>U-31dc</i>	<i>U-32dc</i>
<i>DIRIS Digiware</i>		
Voltage measurement range		
Nominal range	24 ... 48 VDC	60 ... 150 VDC
Min-Max range	19.2 ... 60 VDC	48 ... 180 VDC
Multi-measurement		
DC voltage (V DC)	•	•
Power Quality		
V ripple (voltage ripple)	-	•
V _{rms}	-	•
Alarms		
Measurement thresholds	-	•
History		
Average values	-	•
Reference	4829 0150	4829 0151

Direct voltage adaptors ⁽¹⁾

	<i>U500dc</i>	<i>U1000dc</i>	<i>U1500dc</i>
<i>DIRIS Digiware Udc</i>			
Max. voltage range	200 - 600 VDC	400 - 1200 VDC	1200 - 1650 VDC
Udc module association	U-32dc	U-32dc	U-32dc
Reference	4829 0153	4829 0154	4829 0155

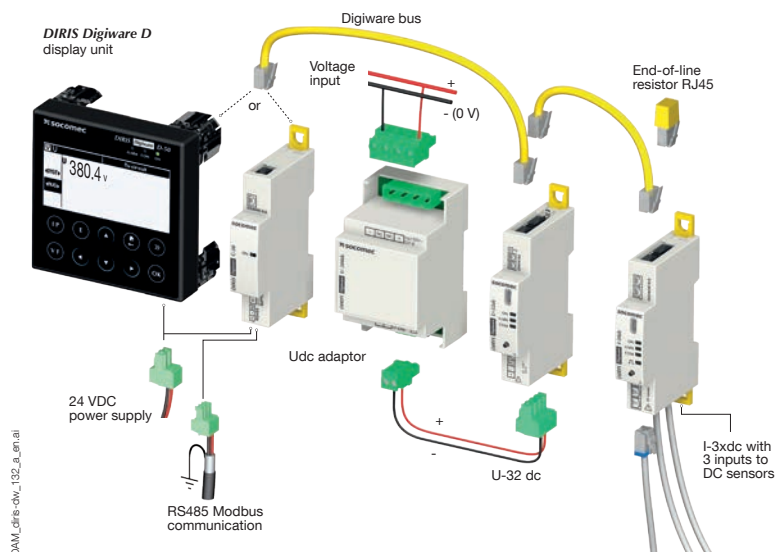





1. U500dc, U1000dc and U1500dc modules can only be associated to the DIRIS Digiware U-32dc module.



















	<i>I-30dc</i>	<i>I-35dc</i>
<i>DIRIS Digiware</i>		
General		
Number of RJ12 DC sensor inputs	3	3
Metering		
± kWh	•	•
P (± kW)	•	•
Load curves / demand profile	-	•
Peak Demand	-	•
Multi-measurement		
DC current (I DC)	•	•
Power Quality		
I ripple (current ripple)	-	•
I rms	-	•
Alarms		
Measurement thresholds	-	•
History		
Average values	-	•
Reference	4829 0156	4829 0157

4

DC current sensors

	DC Solid-core current sensors						
							
Primary (A)	50	100	200	300	400	500	600
Secondary	± 4 V	± 4 V	± 4 V	± 4 V	± 4 V	± 4 V	± 4 V
Window size (in / mm)	0.80 x 0.41 20.4 x 10.4	0.80 x 0.41 20.4 x 10.4	0.80 x 0.41 20.4 x 10.4	0.80 x 0.41 20.4 x 10.4	0.80 x 0.41 20.4 x 10.4	0.80 x 0.41 20.4 x 10.4	0.80 x 0.41 20.4 x 10.4
Accuracy	≤ 1%	≤ 1%	≤ 1%	≤ 1%	≤ 1%	≤ 1%	≤ 1%
Reference	4829 0750	4829 0751	4829 0752	4829 0753	4829 0754	4829 0755	4829 0756

	DC Solid-core current sensors (continued)					
						
Primary (A)	850	1000	1500	2000	2500	5000
Secondary	± 4 V	± 4 V	± 4 V	± 4 V	± 4 V	± 4 V
Window size (in / mm)	2.52 x 0.83 64 x 21	2.52 x 0.83 64 x 21	2.52 x 0.83 64 x 21	2.52 x 0.83 64 x 21	2.52 x 0.83 64 x 21	2.52 x 0.83 64 x 21
Accuracy	≤ 1%	≤ 1%	≤ 1%	≤ 1%	≤ 1%	≤ 1%
Reference	4829 0707	4829 0708	4829 0709	4829 0710	4829 0711	4829 0712



	DC Split-core current sensors									
										
Primary (A)	50	100	200	300	400	500	800	1000	1500	2000
Secondary	± 4 V	± 4 V	± 4 V	± 4 V	± 4 V	± 4 V	± 4 V	± 4 V	± 4 V	± 4 V
Window size (in / mm)	Ø 0.83 / 21	Ø 0.83 / 21	Ø 0.83 / 21	Ø 0.83 / 21	Ø 0.83 / 21	Ø 0.83 / 21	4.09 x 1.57 104 x 40	4.09 x 1.57 104 x 40	4.09 x 1.57 104 x 40	4.09 x 1.57 104 x 40
Accuracy	≤ 1%	≤ 1%	≤ 1%	≤ 1%	≤ 1%	≤ 1%	≤ 1%	≤ 1%	≤ 1%	≤ 1%
Reference	4829 0750	4829 0751	4829 0752	4829 0753	4829 0754	4829 0755	4829 0756	4829 0757	4829 0758	4829 0759

4

RJ12 cables for DC current sensors

RJ12 connection cables	Cable length (ft/m)				
	0.96/0.3	1.64/0.5	3.3/1	6.5/2	16.4/5
Number of cables	Reference	Reference	Reference	Reference	Reference
1	-	-	-	-	4829 0786
3	4829 0782	4829 0783	4829 0784	4829 0785	-

5 Input / output modules

	IO-10	IO-20
<i>DIRIS Digiware</i>		
Inputs / outputs		
Number of digital inputs/outputs	4/2	-
Number of analog inputs	-	2 / 0
Alarms		
Measurement thresholds	•	•
Logical (digital input status)	•	-
History		
Average values	-	•
Demand profiles (pulse meter)	•	-
Reference	4829 0140	4829 0145

5 Digiware Bus cables

	Length	Reference
 Digiware Bus Cables	0.2 ft / 0.06 m	4829 0189
	0.33 ft / 0.10 m	4829 0181
	0.66 ft / 0.20 m	4829 0188
	1.64 ft / 0.50 m	4829 0182
	3.28 ft / 1 m	4829 0183
	6.56 ft / 2 m	4829 0184
	9.84 ft / 3 m	4829 0190
	16.4 ft / 5 m	4829 0186
	32.8 ft / 10 m	4829 0187
	164.04 ft / 50 m roll + 100 connectors	4829 0185

Additional accessories for DIRIS Digiware system

Description	Reference
6.5-ft USB Cable for configuration of DIRIS Digiware system - Type A to Type Micro-B	4829 0050
Spare Digiware Bus terminating resistor (already provided with DIRIS Digiware D, M and C-31)	4829 0180
Power supply P15 100-240VAC/24VDC 15W for Digiware system	4829 0120

When **energy** matters



Single-point Power Metering & Monitoring

DIRIS A & B



RJ12 current sensors

The easiest, fastest way to connect current sensors thanks to a unique RJ12 concept. The mV output signal means no shorting blocks are needed!



Multi-protocol

RS485 or Ethernet, with Modbus RTU, Modbus TCP and BACnet IP protocols to ensure compatibility with your BMS.



PreciSense technology

Unrivalled class 0.5 system accuracy (including current sensors), exceeding revenue grade requirements and ensuring reliable measurements under all conditions



Web interface

Access real time and historical measurements remotely thanks to a free built-in web interface on all Ethernet based power meters.



Cyber security

Industry leading cyber security features to guarantee the confidentiality, integrity and availability of data.

Selection Guide

Single-point Power Metering & Monitoring

DIRIS A & B

Choose your Power Meter

1



DIRIS B-10 / B-30
300 VAC L-N max



DIRIS A-40
300 VAC L-N max



DIRIS A-100/A-200
RJ12 models
600 VAC L-N max



DIRIS A-100/A-200
333 mV models
600 VAC L-N max

Choose your current sensors ⁽¹⁾

2



RJ12 TE, TR/iTR, TF
Solid-core, split-core,
flexible Rogowski



RJ12 TE, TR/iTR, TF
Solid-core, split-core,
flexible Rogowski



RJ12 TE, TR/iTR, TF
Solid-core, split-core,
flexible Rogowski



TR-W & ACTL
333 mV split-core

1. identical current sensors required for a three-phase load

Choose your zero sequence CT for ground leakage monitoring

3

-

-



-

Create your project

www.meter-selector.com



METER SELECTOR
DIGITAL TOOL AVAILABLE







<i>DIRIS</i>	<i>B-10</i>	<i>B-30</i>	<i>A-40</i>	<i>A-40</i>	<i>A-40</i>	<i>A-100</i>	<i>A-100</i>	<i>A-200</i>	<i>A-200</i>
									
Current sensor technology	RJ12	RJ12	RJ12	RJ12	RJ12	RJ12	333 mV	RJ12	333 mV
General									
Format	DIN Rail	DIN Rail	Door mount	Door mount	Door mount	Door mount	Door mount	Door mount	Door mount
Number of current sensor inputs	4	4	3	3	3	4	4	4	4
Available enclosed	-	•	-	•	-	-	-	•	-
Electrical									
Power supply	110 - 240 VAC	110 - 240 VAC	110 - 277 VAC	110 - 277 VAC	110 - 277 VAC	115 - 600 VAC	115 - 600 VAC	115 - 600 VAC	115 - 600 VAC
Voltage measurement	50 - 300 VAC L-N	50 - 300 VAC L-N	50 - 300 VAC L-N	50 - 300 VAC L-N	50 - 300 VAC L-N	50 - 600 VAC L-N	50 - 600 VAC L-N	50 - 600 VAC L-N	50 - 600 VAC L-N
	87 - 520 VAC L-L	87 - 520 VAC L-L	87 - 520 VAC L-L	87 - 520 VAC L-L	87 - 520 VAC L-L	90 - 690 VAC L-L	90 - 690 VAC L-L	90 - 690 VAC L-L	90 - 690 VAC L-L
Communication									
RS485 Modbus RTU	•	•	•	•	•	•	•	•	•
Ethernet (Modbus TCP, BACnet IP)	-	-	-	•	-	-	-	•	•
Profibus DPV1	-	-	-	-	•	-	-	-	-
WEBVIEW web interface	-	-	-	•	-	-	-	•	•
Digital Input / Output	2 / 0	2 / 0	3 / 2	3 / 2	3 / 2	3 / 1	3 / 1	3 / 1	3 / 1
Analog Input / Output	0 / 0	0 / 0	- / -	- / -	- / -	- / -	- / -	- / -	- / -
Energy metering									
± kWh, ± kvarh, kVAh	•	•	•	•	•	•	•	•	•
Σ P (kW), Σ Q (kvar), Σ S (kVA), PF	•	•	•	•	•	•	•	•	•
P (kW), Q (kvar), S (kVA), PF per phase	-	•	•	•	•	•	•	•	•
Predictive Power	-	•	•	•	•	•	•	•	•
Load curves / demand profiles	-	•	•	•	•	•	•	•	•
Peak Demand	-	•	•	•	•	•	•	•	•
Multi-tariff	8	8	8	8	8	4 (with Time of Use)	4 (with Time of Use)	4 (with Time of Use)	4 (with Time of Use)
Multi-measurement									
U12, U23, U31, V1, V2, V3, f	•	•	•	•	•	•	•	•	•
U system, V system	•	•	•	•	•	•	•	•	•
I1, I2, I3, In, I system	•	•	•	•	•	•	•	•	•
Unbalance U, V, I	•	•	•	•	•	•	•	•	•
Phi, cos Phi, tan Phi	•	•	•	•	•	•	•	•	•
Power Quality									
THD U, V, I	•	•	•	•	•	•	•	•	•
Individual Harmonics U, V, I (up to 63rd)	-	•	•	•	•	-	-	•	•
Ground Leakage Monitoring	-	-	-	-	-	-	-	•	-
Crest Factor I1, I2, I3	-	•	•	•	•	•	•	•	•
K-Factor	-	•	•	•	•	•	•	•	•
PQ Events (sags, swells, interruptions, overcurrents)	-	•	•	•	•	•	•	•	•
Waveform capture	-	-	-	-	-	-	-	•	•
Alarms									
Measurement thresholds	-	•	•	•	•	•	•	•	•
System alarms	•	•	•	•	•	•	•	•	•
Protective device	•	•	•	•	•	•	•	•	•
Logical (digital input status)	-	•	•	•	•	•	•	•	•
History									
Average values	-	•	•	•	•	•	•	•	•
Reference	4829 0010	4829 0000	4825 0500	4825 0501	4825 0502	4825 0600	4825 0601	4825 0604	4825 0605





Accessories







Description	Reference
6.5-ft USB Cable for configuration of DIRIS power meters - Type A to Type Micro-B	4829 0050
DIN-rail mounting accessory for DIRIS A-40 and A-100 / A-200	4825 0690

2

RJ12 AC current sensors

Suitable for new installations match the pitch of protective devices	Solid-core current sensors						
							
	<i>TE-18</i>	<i>TE-25</i>	<i>TE-35</i>	<i>TE-45</i>	<i>TE-55</i>	<i>TE-90</i>	<i>TE-90</i>
Nominal current I_n (A) $\leftarrow 5 \dots 2000 \rightarrow$	5 ... 20	25 ... 63	40 ... 160	63 ... 250	160 ... 630	400 ... 1000	600 ... 2000
Real range covered (A) $\leftarrow 0.1 \dots 2400 \rightarrow$	0.1 ... 24	0.5 ... 75.6	0.8 ... 192	1.26 ... 300	3.2 ... 756	8 ... 1200	12 ... 2400
Window (in / mm)	\varnothing 0.33 / 8.4	\varnothing 0.33 / 8.4	0.53 x 0.53 13.5 x 13.5	0.82 x 0.82 21 x 21	1.22 x 1.22 31 x 31	1.61 x 1.61 41 x 41	2.52 x 2.52 64 x 64
Connection	RJ12	RJ12	RJ12	RJ12	RJ12	RJ12	RJ12
Reference	4829 0500	4829 0501	4829 0502	4829 0503	4829 0504	4829 0505	4829 0506

Suitable for existing installations	Split-core current sensors			
				
	<i>TR/iTR-10</i>	<i>TR/iTR-14</i>	<i>TR/iTR-21</i>	<i>TR/iTR-32</i>
Nominal current I_n (A) $\leftarrow 25 \dots 600 \rightarrow$	25 ... 63	40 ... 160	63 ... 250	160 ... 600
Real range covered (A) $\leftarrow 0.5 \dots 720 \rightarrow$	0.5 ... 75	0.8 ... 192	1.26 ... 200	3.2 ... 720
Window (in / mm)	\varnothing 0.39 / 10	\varnothing 0.55 / 14	\varnothing 0.83 / 21	\varnothing 1.26 / 32
Connection	RJ12	RJ12	RJ12	RJ12
Reference	4829 0555 / 4829 0655	4829 0556 / 4829 0656	4829 0557 / 4829 0657	4829 0558 / 4829 0658

Suitable for existing installations with space constraints or with high currents	Flexible Rogowski current sensors					
						
	<i>TF-40</i>	<i>TF-80</i>	<i>TF-120</i>	<i>TF-200</i>	<i>TF-300</i>	<i>TF-600</i>
Nominal current I_n (A) $\leftarrow 100 \dots 6000 \rightarrow$	100...400	150...600	400...2000	600...4000	1600...6000	1600...6000
Real range covered (A) $\leftarrow 2 \dots 7200 \rightarrow$	2...480	3...720	8...2400	12...4800	32...7200	32...7200
Window (in / mm)	\varnothing 1.57 / 40	\varnothing 3.15 / 80	\varnothing 4.72 / 120	\varnothing 7.87 / 200	\varnothing 11.81 / 300	\varnothing 23.62 / 600
Connection	RJ12	RJ12	RJ12	RJ12	RJ12	RJ12
Reference	4829 0573	4829 0574	4829 0575	4829 0576	4829 0577	4829 0578

TF sensors come with a 2m / 6.5 ft RJ12 lead which can be extended via use of female/female RJ12 connector (ref. 4829 0670).









2 RJ12 cables for TE / TR / iTR / TF AC current sensors

RJ12 connection cables	Cable length (ft/m)										
	0.32/0.1	0.64/0.2	0.96/0.3	1.64/0.5	3.3/1	6.5/2	9.84/3	16.4/5	23/7	32.8/10	164/50 + 100 connectors
Number of cables	Reference	Reference	Reference	Reference	Reference	Reference	Reference	Reference	Reference	Reference	Reference
1	-	-	-	-	-	-	-	4829 0602	-	4829 0603	4829 0601
3	4829 0580	4829 0581	4829 0582	4829 0595	4829 0583	4829 0584	4829 0606	4829 0607	4829 0608	4829 0609	-
4	-	-	-	4829 0596	4829 0588	4829 0589	-	-	-	-	-
6	4829 0590	4829 0591	4829 0592	4829 0597	4829 0593	4829 0594	-	-	-	-	-





Accessories

Description	Reference
RJ12 female/female connector (QTY 3)	4829 0670
1A / 5A CT Adaptor with RJ12 output	4829 0599







2 ACTL 333 mV split-core current sensors

Ideal for retrofit applications - high accuracy	Split-core 333 mV current sensors									
										
	ACTL-0750						ACTL-1250			
Primary (A)	20	50	100	150	200	250	250	400	600	
Secondary	333 mV	333 mV	333 mV	333 mV	333 mV	333 mV	333 mV	333 mV	333 mV	
Lead length (ft / m)	8 / 2.4	8 / 2.4	8 / 2.4	8 / 2.4	8 / 2.4	8 / 2.4	8 / 2.4	8 / 2.4	8 / 2.4	
Window size (in / mm)	Ø 0.78 / 20	Ø 0.78 / 20	Ø 0.78 / 20	Ø 0.78 / 20	Ø 0.78 / 20	Ø 0.78 / 20	Ø 1.77 / 45	Ø 1.77 / 45	Ø 1.77 / 45	
Reference	0.75% accuracy	USACTL0750020	USACTL0750050	USACTL0750100	USACTL0750150	USACTL0750200	USACTL0750250	USACTL1250250	USACTL1250400	USACTL1250600
	0.5% accuracy	USACTL0750020C06	USACTL0750050C06	USACTL0750100C06	USACTL0750150C06	USACTL0750200C06	USACTL0750250C06	USACTL1250250C06	USACTL1250400C06	USACTL1250600C06
	0.2% accuracy	-	-	-	-	-	USACTL0750250C02	USACTL1250250C02	USACTL1250400C02	USACTL1250600C02

2 TR-W 333 mV split-core current sensors



Ideal for retrofit applications - compact space	Split-core 333 mV current sensors			
				
	TR-10W	TR-14W	TR-21W	TR-32W
Primary (A)	63	160	250	600
Secondary	333 mV	333 mV	333 mV	333 mV
Lead length (ft / m)	22 / 7	22 / 7	22 / 7	22 / 7
Window size (in / mm)	Ø 0.39 / 10	Ø 0.55 / 14	Ø 0.83 / 21	Ø 1.26 / 32
Reference	194S 5010	194S 5014	194S 5021	194S 5032

3 RJ12 Δ IC Solid-core zero-sequence current transformers

Ideal for new installations								
	Δ IC Ø 8	Δ IC Ø 15	Δ IC Ø 30	Δ IC Ø 50	Δ IC Ø 80	Δ IC Ø 120	Δ IC Ø 200	Δ IC Ø 300
Secondary connection	RJ12	RJ12	RJ12	RJ12	RJ12	RJ12	RJ12	RJ12
Window size (in / mm)	Ø 0.35 / 9	Ø 0.59 / 15	Ø 1.18 / 30	Ø 1.97 / 50	Ø 3.15 / 80	Ø 4.72 / 120	Ø 7.87 / 200	Ø 11.8 / 300
Measurement range	3 mA - 3A	3 mA - 3A	3 mA - 3A	3 mA - 3A	3 mA - 3A	3 mA - 3A	3 mA - 3A	3 mA - 3A
Accuracy	1%	3%	3%	3%	3%	3%	3%	3%
Voltage rating	600 Vac	720 Vac	720 Vac	720 Vac	720 Vac	720 Vac	720 Vac	720 Vac
Reference	4829 0520	4950 6015	4950 6030	4950 6050	4950 6080	4950 6120	4950 6200	4950 6300

Each Δ IC Ø 15-300 zero-sequence CT requires a T-10 RJ12 adaptor (ref. 4829 0620) to connect to the DIRIS A-200.

3 RJ12 Δ IP-R Split-core zero-sequence current transformers

			
	Δ IP Ø 50R	Δ IP Ø 80R	Δ IP Ø 120R
Secondary connection	RJ12	RJ12	RJ12
Window size (in / mm)	Ø 1.97 / 50	Ø 3.15 / 80	Ø 4.72 / 120
Measurement range	3 mA - 3A	3 mA - 3A	3 mA - 3A
Accuracy	3%	3%	3%
Voltage rating	720 Vac	720 Vac	720 Vac
Reference	4750 6051	4750 6081	4750 6121

Each Δ IP-R zero-sequence CT requires a T-10 RJ12 adaptor (ref. 4829 0620) to connect to the DIRIS A-200.

3 RJ12 cables for Δ IC and Δ IP-R zero-sequence current transformers

RJ12 connection cables	Cable length (ft / m)										
	0.32/0.1	0.64/0.2	0.96/0.3	1.64/0.5	3.3/1	6.5/2	9.84/3	16.4/5	23/7	32.8/10	164/50 + 100 connectors
Number of cables	Reference	Reference	Reference	Reference	Reference	Reference	Reference	Reference	Reference	Reference	Reference
1	-	-	-	-	-	-	-	4829 0602	-	4829 0603	4829 0601
3	4829 0580	4829 0581	4829 0582	4829 0595	4829 0583	4829 0584	4829 0606	4829 0607	4829 0608	4829 0609	-
4	-	-	-	4829 0596	4829 0588	4829 0589	-	-	-	-	-
6	4829 0590	4829 0591	4829 0592	4829 0597	4829 0593	4829 0594	-	-	-	-	-

Accessories

Description	Reference
T-10 RJ12 adaptor (necessary to connect to DIRIS A-200 power meter)	4829 0620
DIN Rail mounting accessory ⁽¹⁾	4950 0031
Mounting Bracket Ø30; Ø50; Ø80/120; Ø200; Ø300	4950 0001; 4950 0002; 4950 0003; 4950 0004; 4950 0005

(1) The DIN Rail mounting accessory is supplied with Δ IP-R, but not with Δ IC zero-sequence current transformers.

Enclosed Power Metering & Monitoring

DIRIS DigiBOX A, B & M

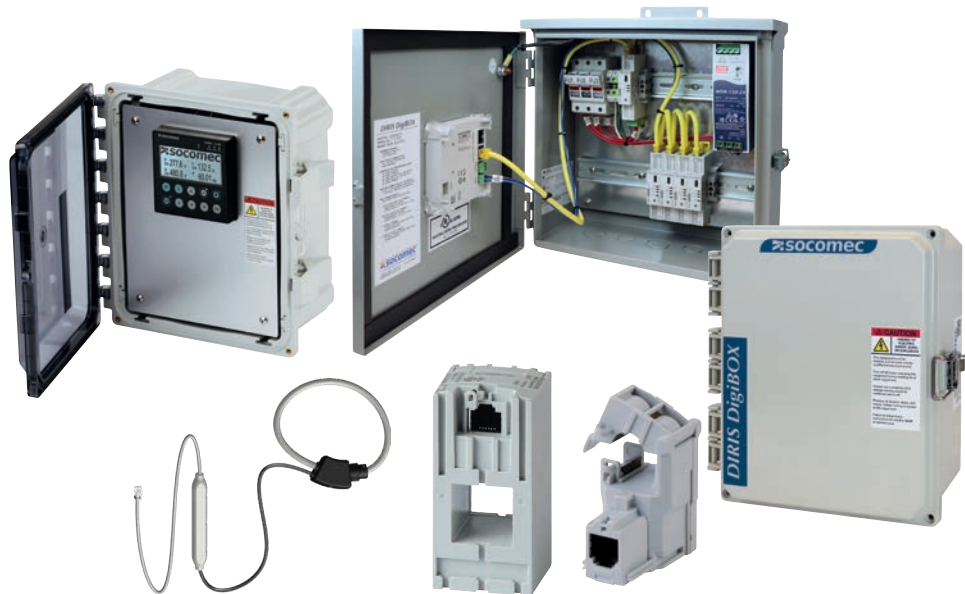

Safe & Reliable

Factory pre-wired internally with fused voltage connections, assembled at our UL 508A panel shop.



PreciSense technology

Unrivaled class 0.5 system accuracy (including current sensors), exceeding revenue grade requirements and ensuring reliable measurements under all conditions.



RJ12 current sensors

The easiest, fastest way to connect current sensors thanks to a unique RJ12 concept. The mV output signal means no shorting blocks are needed!



Multi-protocol

RS485 or Ethernet, with Modbus RTU, Modbus TCP and BACnet IP protocols to ensure compatibility with your BMS.



Web interface

Access real time and historical measurements remotely thanks to a free built-in web interface on all Ethernet based power meters

Selection Guide

Enclosed Power Metering & Monitoring

DIRIS DigiBOX A, B & M

Choose your Enclosed Power Meter

1



DIRIS DigiBOX A
Single-point



DIRIS DigiBOX B
Single-point



DIRIS DigiBOX M
Multi-circuit, up to 24 sensor inputs

Choose your current sensors⁽¹⁾ and RJ12 connection cables

2



TE, TR/iTR, TF

Solid-core, split-core, flexible Rogowski











Create your project
www.meter-selector.com



METER SELECTOR
DIGITAL TOOL AVAILABLE

1 Enclosed Power Meter







	DigiBOX B & A			DigiBOX M4		DigiBOX M8		DigiBOX M4 PRO		DigiBOX M8 PRO	
											
Metering technology	DIRIS B-30	DIRIS A-40	DIRIS A-200	DIRIS Digiware system		DIRIS Digiware system		DIRIS Digiware system		DIRIS Digiware system	
# of metering points (3P)	1	1	1	4		8		4		8	
# of current inputs	4	3	4	12		24		12		24	
Display	-	•	•	-	•	-	•	-	•	-	•
WEBVIEW web interface	-	•	•	-	-	-	-	-	•	-	•
Communication											
RS485 ⁽¹⁾	•	•	•	•	•	•	•	•	•	•	•
Ethernet ⁽²⁾	-	•	•	-	•	-	•	-	•	-	•
Enclosure											
Type	Polycarbonate	Polycarbonate	Polycarbonate	Steel	Steel	Steel	Steel	Steel	Steel	Steel	Steel
Rating	NEMA 4X	NEMA 4X	NEMA 4X	NEMA 12/3R	NEMA 12/3R	NEMA 12/3R	NEMA 12/3R	NEMA 12/3R	NEMA 12/3R	NEMA 12/3R	NEMA 12/3R
Dimensions (H x W x D)	12 x 10 x 6 in	12 x 10 x 6 in	12 x 10 x 6 in	12 x 12 x 6 in	12 x 12 x 6 in	12 x 12 x 6 in	12 x 12 x 6 in	12 x 12 x 6 in	12 x 12 x 6 in	12 x 12 x 6 in	12 x 12 x 6 in
Electrical Characteristics											
Voltage input	110-240 VAC	110-277 VAC	110-600 VAC	200-480 VAC	200-480 VAC	200-480 VAC	200-480 VAC	200-480 VAC	200-480 VAC	200-480 VAC	200-480 VAC
Energy metering											
± kWh, ± kvarh, kVAh	•	•	•	•	•	•	•	•	•	•	•
P (kW), Q (kvar), S (kVA), PF	•	•	•	•	•	•	•	•	•	•	•
P (kW), Q (kvar), S (kVA), PF per phase	•	•	•	•	•	•	•	•	•	•	•
Multi-measurement											
Amps, Volts, Frequency	•	•	•	•	•	•	•	•	•	•	•
Unbalance U, V, I	•	•	•	-	-	-	-	•	•	•	•
Power Quality											
THD U, V, I	•	•	•	-	-	-	-	•	•	•	•
Individual Harmonics V, U, I (up to 63rd)	•	•	•	-	-	-	-	•	•	•	•
PQ Events (sags, swells, interruptions and overcurrents)	•	•	•	-	-	-	-	•	•	•	•
Waveform capture	-	-	•	-	-	-	-	-	-	-	-
Alarms											
Measurement thresholds	•	•	•	Power / Energies	Power / Energies	Power / Energies	Power / Energies	•	•	•	•
System alarms	•	•	•	•	•	•	•	•	•	•	•
Email notifications	-	•	•	-	-	-	-	-	•	-	•
Reference	USDBBB30ND0	USDBPA40ET	USDBPA200RJ	USDBB04ND0	USDBB04D50	USDBB08ND0	USDBB08D50	USDBP04ND0	USDBP04D70	USDBP08ND0	USDBP08D70





1. Supported RS485 protocol: Modbus RTU.







2. Supported Ethernet protocols: ModbusTCP/IP, BACnet IP

Description	Reference
6.5-ft USB Cable for configuration of DIRIS power meters - Type A to Type Micro-B	4829 0050

2 RJ12 AC current sensors

Suitable for new installations match the pitch of protective devices	Solid-core current sensors						
							
	TE-18	TE-25	TE-35	TE-45	TE-55	TE-55	TE-90
Nominal current I_n (A) $\leftarrow 5 \dots 2000 \rightarrow$	5 ... 20	25 ... 63	40 ... 160	63 ... 250	160 ... 630	400 ... 1000	600 ... 2000
Real range covered (A) $\leftarrow 0.1 \dots 2400 \rightarrow$	0.1 ... 24	0.5 ... 75.6	0.8 ... 192	1.26 ... 300	3.2 ... 756	8 ... 1200	12 ... 2400
Window (in / mm)	\varnothing 0.33 / 8.4	\varnothing 0.33 / 8.4	0.53 x 0.53 / 13.5 x 13.5	0.82 x 0.82 / 21 x 21	1.22 x 1.22 / 31 x 31	1.61 x 1.61 / 41 x 41	2.52 x 2.52 / 64 x 64
Connection	RJ12	RJ12	RJ12	RJ12	RJ12	RJ12	RJ12
Reference	4829 0500	4829 0501	4829 0502	4829 0503	4829 0504	4829 0505	4829 0506

Suitable for existing installations	Split-core current sensors			
				
	TR/iTR-10	TR/iTR-14	TR/iTR-21	TR/iTR-32
Nominal current I_n (A) $\leftarrow 25 \dots 600 \rightarrow$	25 ... 63	40 ... 160	63 ... 250	160 ... 600
Real range covered (A) $\leftarrow 0.5 \dots 720 \rightarrow$	0.5 ... 75	0.8 ... 192	1.26 ... 300	3.2 ... 720
Window (in / mm)	\varnothing 0.39 / 10	\varnothing 0.55 / 14	\varnothing 0.83 / 21	\varnothing 1.26 / 32
Connection	RJ12	RJ12	RJ12	RJ12
Reference	4829 0555 / 4829 0655	4829 0556 / 4829 0656	4829 0557 / 4829 0657	4829 0558 / 4829 0658

Suitable for existing installations with space constraints or with high currents	Flexible current sensors					
						
	TF-40	TF-80	TF-120	TF-200	TF-300	TF-600
Nominal current I_n (A) $\leftarrow 100 \dots 6000 \rightarrow$	100...400	150...600	400...2000	600...4000	1600...6000	1600...6000
Real range covered (A) $\leftarrow 2 \dots 7200 \rightarrow$	2...480	3...720	8...2400	12...4800	32...7200	32...7200
Window (in / mm)	\varnothing 1.57 / 40	\varnothing 3.15 / 80	\varnothing 4.72 / 120	\varnothing 7.87 / 200	\varnothing 11.81 / 300	\varnothing 23.62 / 600
Connection	RJ12	RJ12	RJ12	RJ12	RJ12	RJ12
Reference	4829 0573	4829 0574	4829 0575	4829 0576	4829 0577	4829 0578

TF sensors come with a 2m / 6.5 ft RJ12 lead which can be extended via use of female/female RJ12 connector (ref. 4829 0670).

2 RJ12 cables for TE / TR / iTR / TF AC current sensors

RJ12 connection cables	Cable length (ft/m)										
	0.32/0.1	0.64/0.2	0.96/0.3	1.64/0.5	3.3/1	6.5/2	9.84/3	16.4/5	23/7	32.8/10	164/50 + 100 connectors
Number of cables	Reference	Reference	Reference	Reference	Reference	Reference	Reference	Reference	Reference	Reference	Reference
1	-	-	-	-	-	-	-	4829 0602	-	4829 0603	4829 0601
3	4829 0580	4829 0581	4829 0582	4829 0595	4829 0583	4829 0584	4829 0606	4829 0607	4829 0608	4829 0609	-
4	-	-	-	4829 0596	4829 0588	4829 0589	-	-	-	-	-
6	4829 0590	4829 0591	4829 0592	4829 0597	4829 0593	4829 0594	-	-	-	-	-

Enclosed multi-point sub-metering

DIRIS MCM



Multi-circuit

Up to (16) three-phase meters in one small physical footprint, with (48) independent current sensor inputs.



mV current sensors

Split-core and Rogowski current sensors are mV based and can be connected safely under load, even with meter cover removed and voltage applied.



Safe

No circuitry or live parts accessible on the meter, allowing to safely operate it even with cover removed and voltage applied.



CT correct algorithm

Cutting-edge algorithm detects potential wiring or configuration errors and proposes the adequate software changes.



Optional wireless interface

Multi-drop Ethernet runs can be replaced with a secure local wireless network, significantly reducing installation and wiring costs.

Selection Guide

Enclosed multi-point sub-metering

DIRIS MCM

Choose your sub-meter and optional wireless interfaces

1



DIRIS MCM-16
Power meter, 16 CT inputs



DIRIS MCM-48
Power meter, 48 CT inputs



RF END-Node
Wireless transmitter



RF HUB-Node
Wireless receiver

Choose your current sensors

2



TR-W
333 mV, compact
Up to 600A



ACCU-CT SENSORS
333 mV, high accuracy
Up to 600A



ROG
131 mV @1 kA, 2 wires
Up to 4000A

1 Enclosed multi-point sub-meter









DIRIS MCM	MCM-16-N-N	MCM-16-D-N	MCM-16-D-D	MCM-48-N-N	MCM-48-N-D	MCM-48-D-N	MCM-48-D-D
General							
Number of current sensor inputs	16	16	16	48	48	48	48
Type of current sensors	333 mV 131 mV Rogowski	333 mV 131 mV Rogowski	333 mV 131 mV Rogowski	333 mV 131 mV Rogowski	333 mV 131 mV Rogowski	333 mV 131 mV Rogowski	333 mV 131 mV Rogowski
Disconnect Switch			•		•		•
Display		•	•			•	•
Communication							
RS485	Modbus RTU	Modbus RTU	Modbus RTU	Modbus RTU	Modbus RTU	Modbus RTU	Modbus RTU
Ethernet	Modbus TCP BACnet IP	Modbus TCP BACnet IP	Modbus TCP BACnet IP	Modbus TCP BACnet IP	Modbus TCP BACnet IP	Modbus TCP BACnet IP	Modbus TCP BACnet IP
Wireless	o	o	o	o	o	o	o
Electrical							
Number of voltage inputs	2	2	2	2	2	2	2
Energy metering							
±kWh, ±kvarh, kVAh	•	•	•	•	•	•	•
ΣP (kW), ΣQ (kvar), ΣS (kVA), ΣPF	•	•	•	•	•	•	•
P (kW), Q (kvar), S (kVA), PF per phase	•	•	•	•	•	•	•
Demand & Peak Demand	•	•	•	•	•	•	•
Multi - measurement							
U12, U23, U31, V1, V2, V3, f	•	•	•	•	•	•	•
U system, V system	•	•	•	•	•	•	•
I1, I2, I3, In	•	•	•	•	•	•	•
I system	•	•	•	•	•	•	•
Power quality							
THD U, V, I	•	•	•	•	•	•	•
Reference	4827 16NN	4827 16DN	4827 16DD	4827 0548	4827 0549	4827 48DN	4827 48DD

o - Wireless RF System optional





1 Wireless interfaces

	RF END-Node	RF HUB-Node
RF wireless system		
Communication		
RS485	Input Max. (16) Modbus slave devices	Output
Ethernet	-	Output
Wireless	Transmitter	Receiver Max. (8) RF END-Node per HUB-Node
Reference	4899 0800	4899 0801





3 ACTL 333 mV split-core current sensors

Ideal for retrofit applications - high accuracy		Split-core 333 mV current sensors									
											
		ACTL-0750					ACTL-1250				
Primary (A)		20	50	100	150	200	250	250	400	600	
Secondary		333 mV	333 mV	333 mV	333 mV	333 mV	333 mV	333 mV	333 mV	333 mV	
Lead length (ft / m)		8 / 2.4	8 / 2.4	8 / 2.4	8 / 2.4	8 / 2.4	8 / 2.4	8 / 2.4	8 / 2.4	8 / 2.4	
Window size (in / mm)		Ø 0.78 / 20	Ø 0.78 / 20	Ø 0.78 / 20	Ø 0.78 / 20	Ø 0.78 / 20	Ø 0.78 / 20	Ø 1.77 / 45	Ø 1.77 / 45	Ø 1.77 / 45	
Reference	0.75% accuracy	USACTL0750020	USACTL0750050	USACTL0750100	USACTL0750150	USACTL0750200	USACTL0750250	USACTL1250250	USACTL1250400	USACTL1250600	
	0.5% accuracy	USACTL0750020C06	USACTL0750050C06	USACTL0750100C06	USACTL0750150C06	USACTL0750200C06	USACTL0750250C06	USACTL1250250C06	USACTL1250400C06	USACTL1250600C06	
	0.2% accuracy	-	-	-	-	-	USACTL0750250C02	USACTL1250250C02	USACTL1250400C02	USACTL1250600C02	

3 TR-W 333 mV split-core current sensors

Ideal for retrofit applications - compact space		Split-core 333 mV current sensors			
					
		TR-10W	TR-14W	TR-21W	TR-32W
Primary (A)		63	160	250	600
Secondary		333 mV	333 mV	333 mV	333 mV
Lead length (ft / m)		22 / 7	22 / 7	22 / 7	22 / 7
Window size (in / mm)		Ø 0.39 / 10	Ø 0.55 / 14	Ø 0.83 / 21	Ø 1.26 / 32
Accuracy		0.5%	0.5%	0.5%	0.5%
Reference		194S 5010	194S 5014	194S 5021	194S 5032

3 Rogowski 131 mV current sensors (only compatible with DIRIS MCM-48 power meter)

Ideal for busbars or higher currents		Rogowski 131 mV current sensors			
					
		ROG-80	ROG-120	ROG-200	ROG-300
Output signal		131mV / kA @ 60Hz Max. 4000 A	131mV / kA @ 60Hz Max. 4000 A	131mV / kA @ 60Hz Max. 4000 A	131mV / kA @ 60Hz Max. 4000 A
Lead length (ft / m)		22 / 7	22 / 7	22 / 7	22 / 7
Window size (in / mm)		Ø 3.15 / 80	Ø 4.7 / 120	Ø 7.8 / 200	Ø 11.8 / 300
Accuracy		0.5%	0.5%	0.5%	0.5%

DIRIS Digiware D

Multi-point display and communication gateway



DIRIS Digiware D-50/D-70



Function

DIRIS Digiware D-50 and D-70 remote displays allow local visualization of measurements from DIRIS Digiware modules, and centralize the 24 VDC power supply and communication bus to a single device.

The D-50 and D-70 displays also act as the Ethernet gateway for all slave devices connected on the Digiware and RS485 bus.

The D-50 and D-70 displays offer a wide range of functionalities, including:

- memory extension for connected devices
- automatic export of logged consumption and data via MQTT or FTP(S).
- notification emails if there is an alarm on one of the connected devices (SMTPS)
- automatic time synchronization of all connected devices via SNTP.

Advantages

Plug & Play

- Direct Digiware and RS485-to-Ethernet gateway.
- Automatic detection of connected devices.
- Easy setup.
- Safety Extra-Low Voltage 24 VDC power supply.

Multi-circuit

- One display to visualize measurements from up to 196 circuits.
- Quick access button to easily scroll through the different circuits.

Embedded webserver

WEBVIEW-M is embedded in the D-70 display to visualize measurements and consumptions remotely on a web-browser and without any license fees.

Cybersecurity

D-50 and D-70 displays include advanced cybersecurity features in compliance with IEC 62443 for secure data transmission and reduce the risk of cyberattacks:

- Customized security policy (blocking or restricting certain protocols and services);
- HTTPS secured navigation using TLS/SSL certificates;
- Secured data exports (FTPS, MQTT, SMTPS);
- Firewalls and whitelist protocols to guard against denial-of-service attacks.

Advanced connectivity

The D-50/D-70 displays communicate measurement data to any BMS/SCADA system using multiple protocols: Modbus RTU, Modbus TCP, BACnet IP and SNMP v1, v2, v3 (encrypted).

The solution for

- > Data center
- > Industry
- > Buildings



Strong points

- > Plug & Play
- > Multi-circuit
- > Embedded webserver
- > Advanced connectivity
- > Cybersecurity

Compliance with standards

- > UL 61010-1, CSA C22.22 No.61010-1, Guide FTRZ/PICQ, File E257746



- > IEC 62974-1 (Energy server)



- > IEC 62443 (Cybersecurity)

- > ISO 14025



Create your project

- > Find the best DIRIS Digiware architecture:
www.meter-selector.com



Application		
		
DIRIS Digiware	D-50	D-70
Digiware Bus	•	•
RS485	Configurable as Modbus Master or Slave	Configurable as Modbus Master or Slave
Ethernet	Modbus TCP BACnet IP SNMP MQTT, FTP(S) (data export) SMTP(S) (email notification) SNTP (time synchronization)	Modbus TCP BACnet IP SNMP MQTT, FTP(S) (data export) SMTP(S) (email notification) SNTP (time synchronization)
Webserver	WEB-CONFIG	WEBVIEW-M

Functions



WEBVIEW-M

Embedded web server in the DIRIS Digiware D-70 display

WEBVIEW-M allows the display and remote monitoring of all the electric parameters measured by up to 32 devices. They are displayed in the form of overview screens, graphs or tables for clear and user-friendly analysis.

Access to WEBVIEW is made by a web browser on a PC or tablet and offers multiple features such as the automatic export of data via FTPS or e-mail notification in the presence of alarms (SMTPS).

The Photoview application displays measurements on a customized background picture such as a one-line diagram, an electrical panel, or a site map.

Accessories

DIN rail mounting kit

The accessory allows you to install the DIRIS Digiware D-50/D-70 display on a DIN rail.

This kit is not included with the displays and must be ordered separately.

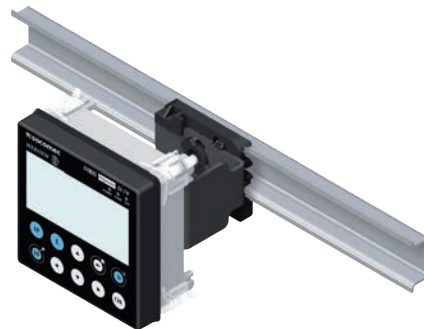

DIRIS Digiware D

Multipoint display and communication gateway

Dimensions (in/mm)

DIRIS Digiware D-50/D-70

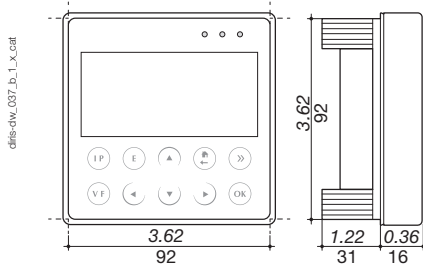

DIRIS Digiware C-31

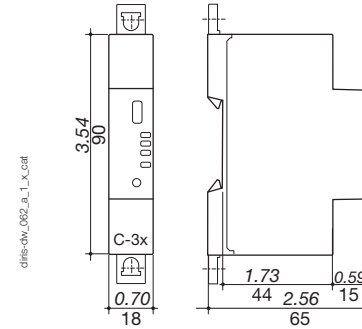

Power Supply Sizing

Device consumption

Product	Power delivered (W)	Power consumed (W)
Power supply		
P15 100-240 VAC / 24 VDC	15	
P30 100-240 VAC / 24 VDC	20	
Digiware Bus cables		
164 feet / 50 meter package		1.5
System interfaces		
DIRIS Digiware D-50/D-70		2.5
DIRIS Digiware C-31		0.8
Voltage modules		
DIRIS Digiware U-xx		0.72
DIRIS Digiware U-3xdc		0.6
Current modules		
DIRIS Digiware I-3x		0.52
DIRIS Digiware I-4x		1.125
DIRIS Digiware I-6x		0.7
DIRIS Digiware I-3xdc (+ 3 DC current sensors)		2
DIRIS Digiware S-xx		0.35
DIRIS Digiware BCM		1.25
Input/output modules		
DIRIS Digiware IO-10/IO-20		0.5
Repeater		
DIRIS Digiware C-32		1.5

Calculation rules for the max. number of products on the Digiware Bus

The total power consumed by the equipment connected to the Digiware Bus must not exceed the power delivered by the 24 VDC supply.

The power supply must not exceed 20 W/168°F/70°C or 27 W/104°F/40°C.

Size with P15 power supply (ref: 4829 0120) delivering 15 W

For example, it is possible to use

- 1 DIRIS Digiware D-50 display (2.5 W)
- 1 DIRIS Digiware voltage module U-xx (0.72 W)
- 164 feet / 50 meters of cable (1.5 W)

and

- 19 DIRIS Digiware current modules I-3x (19 x 0.52 = 9.9 W)
⇒ Total power = 14.845 W

or

- 9 DIRIS Digiware current modules I-4x (9 x 1.125 = 10.125 W)
⇒ Total power = 14.345 W.

Size with a 24 VDC power supply delivering a maximum of 20 W

(Power supply P30 ref: 4729 0603)

For example, it is possible to use

- 1 DIRIS Digiware D-50 display (2.5 W)
- 1 DIRIS Digiware voltage module U-xx (0.72 W)
- 164 feet / 50 meters of cable (1.5 W)

and

- 29 DIRIS Digiware current modules I-3x (29 x 0.52 = 15.1 W)
⇒ Total power = 19.82 W

or

- 13 DIRIS Digiware current modules I-4x (13 x 1.125 = 14.63)
⇒ Total power = 19.35 W.

Repeater

Whenever the power consumption is higher than 20 W or the distance is greater than 328 ft / 100 m, a DIRIS Digiware C-32 repeater is required.

In a DIRIS Digiware system, a maximum of 2 repeaters may be used.

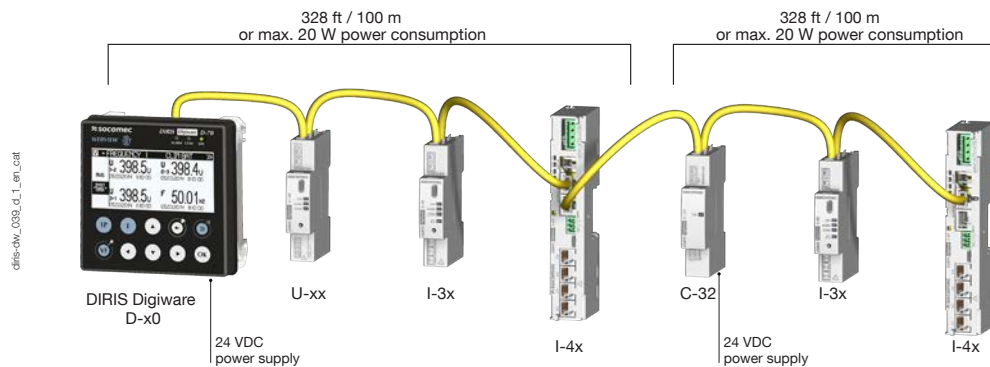

Connections

RS485 slave mode

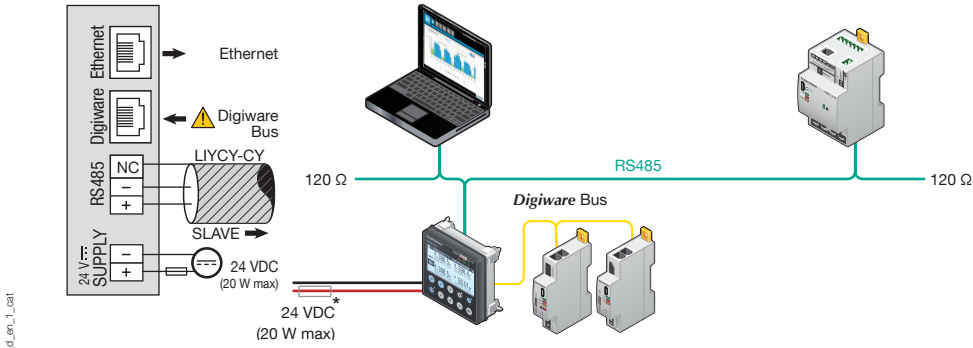

(*) 1 A / 24 VDC fuse protection is recommended if the 24 VDC power supply is not provided by Socomec.

RS485 master mode

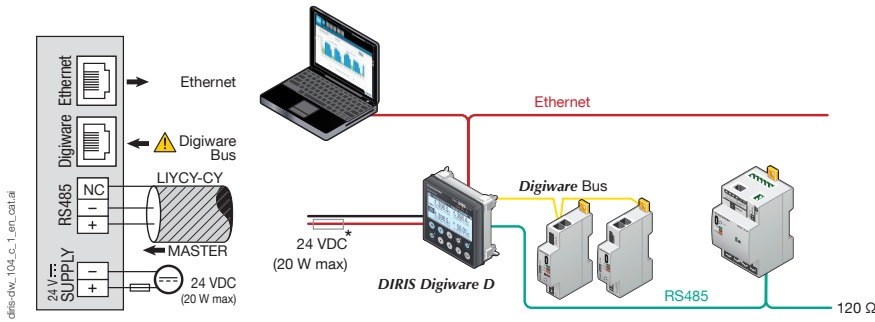

(*) 1 A / 24 VDC fuse protection is recommended if the 24 VDC power supply is not provided by Socomec.

DIRIS Digiware D

Multipoint display and communication gateway

Technical characteristics

Mechanical characteristics

Type of screen	Capacitive touch-screen technology, 10 keys
Screen resolution	350 x 160 pixels
Ingress Protection	IP65, front face

Electrical characteristics

Power supply	24 VDC \pm 10% - 20 W max
Power consumption	2.5 VA
Battery lifetime	10 years
Connection	Removable screw terminal block, 2 positions, AWG 16 ... AWG 24 or 0.25 ... 1.5 mm ² stranded or solid cable

Environmental characteristics

Storage temperature	-13 ... +158 °F / -25 ... +70 °C
Operating temperature	+14 ... +131 °F / -10 ... +55 °C
Humidity	0% to 97% RH / +131°F/+55°C, non condensing
Operating altitude	≤ 6560 ft / 2000 m

Communication characteristics

Digiware Bus	
Connection type	Socomec RJ45 cable
Function	Proprietary bus connecting Digiware units
RS485	
Connection type	Half-Duplex, 2-3 wires
Protocol	Modbus RTU, configurable as Master or Slave
Baudrate	9600 bds (max. 10 devices) 38400 bds - 115200 bds (max. 32 devices)
Ethernet	
Connection type	RJ45 10/100 Mbps
Protocol	Modbus TCP/IP, BACnet IP, SNMP v1, v2, v3, HTTP(S), FTP(S), SMTP(S), MQTT
USB	
Connection type	USB Type Micro-B
Protocol	Modbus RTU over USB
Function	Firmware upgrade and configuration

References

DIRIS Digiware D		Reference
D-50	Display and multi-protocol Ethernet gateway	4829 0204
D-70	Display and multi-protocol Ethernet gateway with embedded WEBVIEW-M web server	4829 0203

Power supply & repeater		Reference
P15	Power supply 100-240 VAC/ 24 VDC 15 W	4829 0120
P30	Power supply 100-240 VAC/ 24 VDC 20 W	4729 0603
C-32	Power supply repeater for Digiware system	4829 0103

Accessories	Sold in multiples of	Reference
2-pole RM Class CC fuse holder to protect power supply input	6	5705 0002
Digiware Bus terminating resistor (already supplied with DIRIS Digiware C, M & D)	1	4829 0180
6.5-ft USB Cable for configuration - Type A to Type Micro-B	1	4829 0050
DIN rail mounting kit for DIRIS Digiware D-50/D-70	1	4829 0230

Digiware bus cables ⁽¹⁾		Reference
RJ45 cables for Digiware Bus	Length 0.20 ft / 0.06 m	4829 0189
	Length 0.32 ft / 0.10 m	4829 0181
	Length 0.66 ft / 0.20 m	4829 0188
	Length 1.64 ft / 0.50 m	4829 0182
	Length 3.28 ft / 1 m	4829 0183
	Length 6.56 ft / 2 m	4829 0184
	Length 9.84 ft / 3 m	4829 0190
	Length 16.4 ft / 5 m	4829 0186
	Length 32.8 ft / 10 m	4829 0187
	164.04 ft / 50 m reel + 100 connectors	4829 0185

(1) To guarantee the proper operation of the DIRIS Digiware system, do not substitute Socomec Digiware bus cables with standard Ethernet RJ45 cables.

Commissioning		Reference
1/2 day remote commissioning	Remote commissioning including installation verification, programming and communication testing	9230100027
1/2 day on-site commissioning	On-site commissioning including installation verification, programming and communication testing	9230100004

Expert Services

Our service engineers are an essential part of our team, and they are dedicated to ensuring your power monitoring system provides accurate and reliable measurements to your EPMS software or SCADA system.

Our services include:

- > Site audits to verify the proper wiring of your system
- > Personnel training on how to configure, operate and maintain power monitoring equipment and associated software
- > Remote and on-site commissioning to ensure that your system is up and running quickly, with peace of mind.

For further information, please contact your nearest SOCOMEC branch.



DIRIS Digiware M

Multi-protocol communication gateway



DIRIS Digiware M-50 - M-70



Function

The **DIRIS Digiware M-50 and M-70** communication gateways are the access point for the DIRIS Digiware system, centralizing the 24 VDC power supply and communication to a single device.

The M-50 and M-70 act as the Ethernet gateway for all the devices connected on the Digiware or RS485 bus, and integrate a web server to configure the network parameters and to remotely display measurement data.

Advantages

Plug & Play

- Direct Digiware and RS485 to Ethernet gateway.
- Automatic detection of connected devices.
- Easy setup.
- Safety Extra-Low Voltage 24 VDC power supply.

Advanced connectivity

- Ethernet output for communication using multiple protocols: Modbus TCP, BACnet IP and SNMP v1, v2, v3 (encrypted) to suit any metering and power monitoring application.
- Possible to configure as RS485 slave, for example to communicate measurement data to a second PLC.
- IoT MQTT data push to simplify integration to third-party EMS/BMS

The M-50 and M-70 gateways offer a wide range of functionalities, including:

- memory extension for connected devices
- automatic export of logged consumption and data via MQTT or FTP(S).
- notification emails if there is an alarm on one of the connected devices (SMTPS)
- automatic time synchronization of all connected devices via SNTP

Embedded web server

WEBVIEW-M embedded in the M-70 and available without license fees, allows users to visualize and analyze real-time and logged data due to graphical tools that are user-friendly and easily accessible to all.

Cyber security

M-50 and M-70 gateways include advanced cybersecurity features in compliance with IEC 62443 for secure data transmission and reduce the risk of cyberattacks:

- Customized security policy (blocking or restricting certain protocols and services);
- HTTPS secured navigation using TLS/SSL certificates;
- Secured data exports (FTPS, MQTT, SMTPS);
- Firewalls and whitelist protocols to guard against denial-of-service attacks.

The solution for

- > Building
- > Industry
- > Infrastructure
- > Data Center



Strong points

- > Plug & Play
- > Advanced connectivity
- > Embedded web server
- > Cyber security

Compliance with standards

- > UL 61010-1, CSA-C22.22 No. 61010-1, Guide FTRZ/PICQ, File E257746



- > IEC 62974-1 (Energy Server standard)





- > IEC 62443 (Cyber security)



Create your project

- > Find the best DIRIS Digiware configuration: www.meter-selector.com



Application	Multi-protocol communication gateway	
		
DIRIS Digiware M	M-50	M-70
Digiware Bus	•	•
RS485	Configurable as Modbus Master or Slave	Configurable as Modbus Master or Slave
Ethernet	Modbus TCP BACnet IP SNMP MQTT, FTP(S) (data export) SMTP(S) (email notification) SNTP (time synchronization)	Modbus TCP BACnet IP SNMP MQTT, FTP(S) (data export) SMTP(S) (email notification) SNTP (time synchronization)
Webserver	WEB-CONFIG	WEBVIEW-M

Architecture

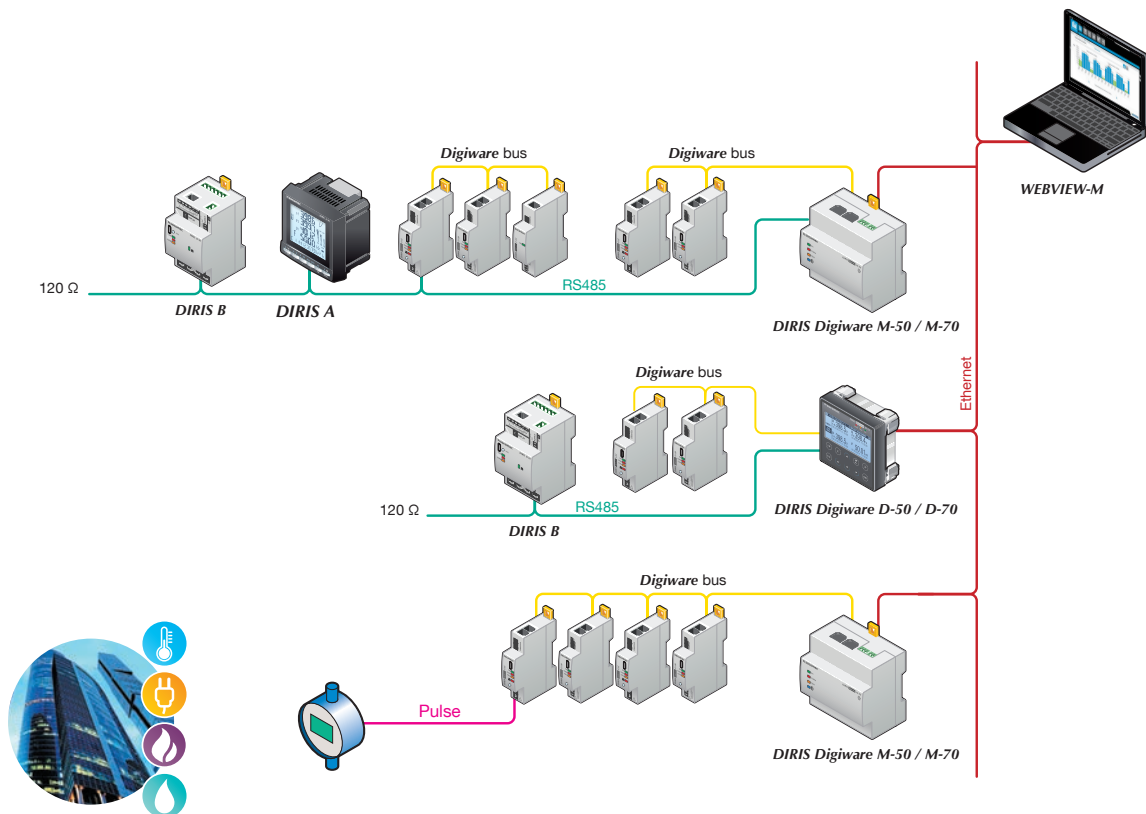

diris-dvw_109_a_us#

Embedded webserver

WEB-CONFIG (M-50)

The M-50 gateway includes a WEB-CONFIG allowing you to:

- configure the device hierarchy and data access
- block or restrict access to certain peripherals, protocols or services

WEBVIEW-M (M-70)

In addition to the WEB-CONFIG, the M-70 gateway allows a remote visualization of data on the embedded WEBVIEW-M software, available without license fees.

- Real-time measurements
- On-going and terminated alarms
- Consumption curves and load curves per load or usage
- Photoview: displays electrical parameters on a customized background such as a site map, an electrical diagram or a panel picture to provide an overview of your electrical installation

Data logging

The M-70 gateway extends the memory of connected devices so you can log a year's worth of measurements, load curves and consumption curves.

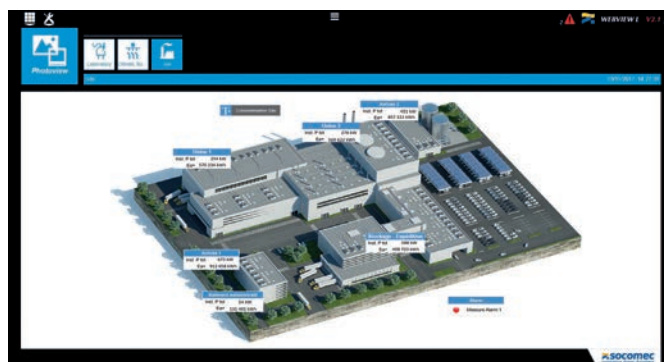
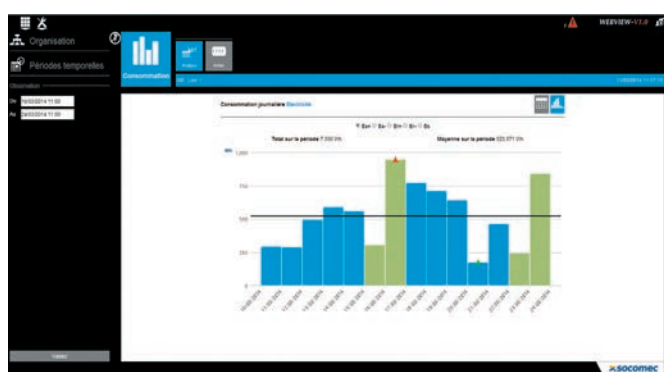

Power Supply Sizing

Device consumption

Device	Power supplied (W)
Power supply	
P15 100-240 VAC / 24 VDC	15
P30 100-240 VAC / 24 VDC	20
Device	Power consumed (W)
Digiware Bus cables	
164 feet / 50 meter package	1.5
System interfaces	
DIRIS Digiware C-31	0.8
DIRIS Digiware D-50/D-70	2.5
DIRIS Digiware M-50/M-70	2.5
Voltage modules	
DIRIS Digiware U-xx	0.72
DIRIS Digiware U-3xdc	0.6
Current modules	
DIRIS Digiware I-3x	0.52
DIRIS Digiware I-4x	1.125
DIRIS Digiware I-6x	0.7
DIRIS Digiware I-3xdc (+ 3 DC current sensors)	2
DIRIS Digiware S-xx	0.35
DIRIS Digiware BCM	1.25
Input/output modules	
DIRIS Digiware IO-10/IO-20	0.5
Repeater	
DIRIS Digiware C-32	1.5

Calculation rules for the max. number of devices on the Digiware bus

The total power consumed by the devices connected to the Digiware bus must not exceed the power from the 24 VDC supply.
The power supply must not exceed 20 W / 158 °F / 70 °C or 27 W / 104 °F / 40 °C.

Size with P15 power supply (ref. 4829 0120) delivering 15 W

For example, it is possible to use

- 1 DIRIS Digiware M-50 gateway (2.5 W)
- 1 DIRIS Digiware voltage module U-xx (0.72 W)
- 164 ft / 50 m of cable (1.5 W)

and

- 29 DIRIS Digiware current modules S-xx (29x 0.35 = 10.15 W)
⇒ Total power = 14.87 W

or

- 9 DIRIS Digiware current modules I-4x (9 x 1.125 = 10.125 W)
⇒ Total power = 14.845 W.

Size with a 24 VDC power supply delivering a maximum of 20 W (P30 ref. 4729 0603)

Possible options include:

- 1 DIRIS Digiware M-50 gateway (2.5 W)
- 1 DIRIS Digiware voltage module U-xx (0.72 W)
- 164 ft / 50 m of cable (1.5 W)

and

- 29 DIRIS Digiware current modules I-3x (30 x 0.52 = 15.08 W)
⇒ Total power = 19.8 W

or

- 14 DIRIS Digiware current modules I-4x (13 x 1.125 = 15.72)
⇒ Total power = 19.345 W.

Repeater

With power consumptions higher than 20 W or distances greater than 328 ft / 100 m, a DIRIS Digiware C-32 repeater is required.
In a DIRIS Digiware system, a maximum of 2 repeaters may be used.

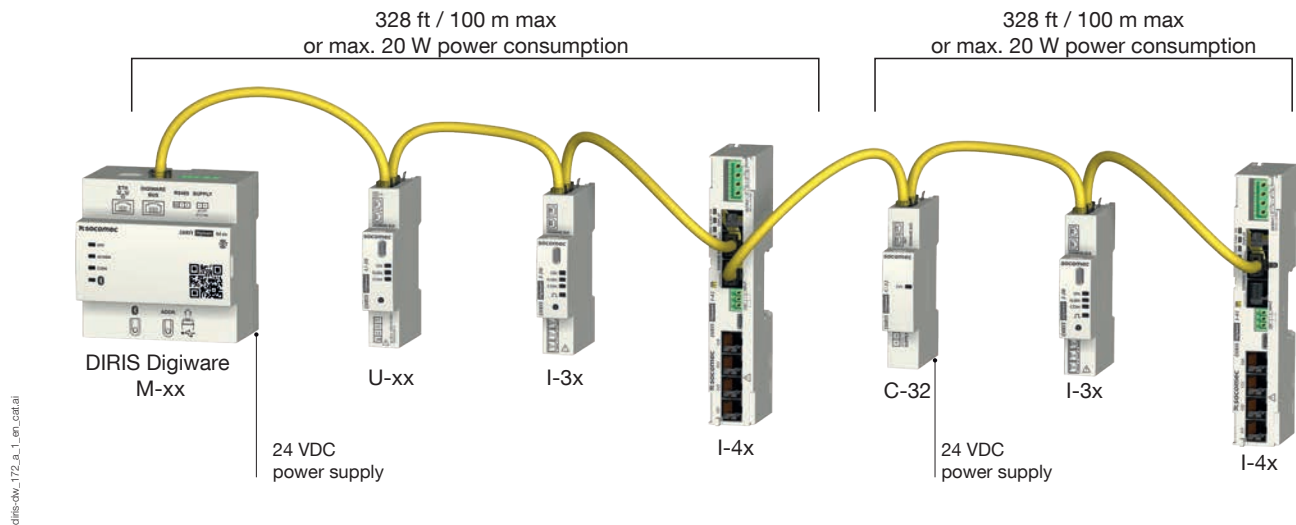

diris-dw_172_a_1_en_cat.ai

Dimensions (in/mm)

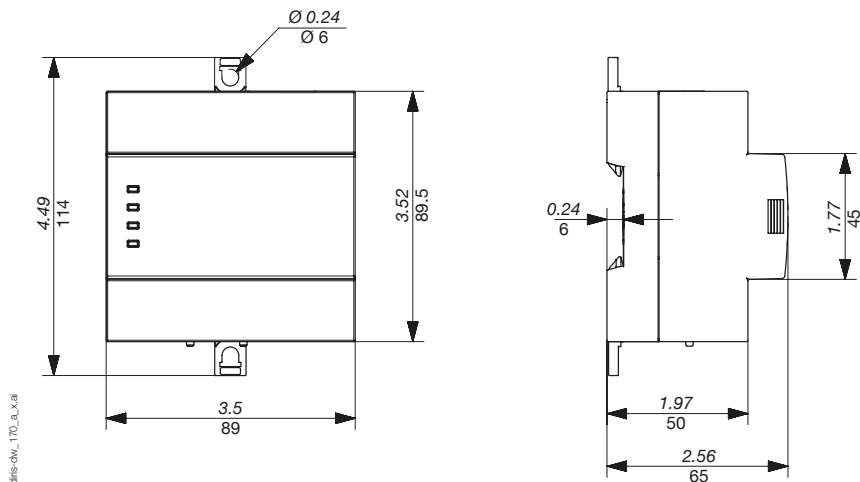

Technical characteristics

Mechanical characteristics

Mounting	DIN-rail or back plate
Protection degree	IP40, front face

Electrical characteristics

Power supply	24 VDC \pm 10% - 20 W max
Power consumption	2.5 VA
Battery lifetime	10 years
Connection	Removable screw terminal block, 2 positions, AWG 16 ... AWG 24 or 0.25 ... 1.5 mm ² stranded or solid cable

Environmental characteristics

Storage temperature	-13 ... +158 °F / -25 ... +70°C
Operating temperature	+14 ... +131 °F / -10 ... +55°C
Humidity	0% to 97% RH / +131°F/+55°C, non condensing
Operating altitude	≤ 6560 ft / 2000 m

Communication characteristics

Digiware Bus	
Connection type	Socomec RJ45 cable
Function	Proprietary bus connecting Digiware units
RS485	
Connection type	Half-Duplex, 2-3 wires
Protocol	Modbus RTU, configurable as Master or Slave
Baudrate	9600 bds (max. 10 devices) 38400 bds - 115200 bds (max. 32 devices)
Ethernet	
Connection type	RJ45 10/100 Mbps
Protocol	Modbus TCP/IP, BACnet IP, SNMP v1, v2, v3, HTTP(S), FTP(S), SMTP(S), MQTT
USB	
Connection type	USB Type Micro-B
Protocol	Modbus RTU over USB
Function	Firmware upgrade and configuration

References

DIRIS Digiware M		Reference
M-50	Multi-protocol Ethernet gateway	4829 0221
M-70	Multi-protocol Ethernet gateway with embedded WEBVIEW-M web server	4829 0222

Power supply & repeater		Reference
P15	Power supply 100-240 VAC/ 24 VDC 15 W	4829 0120
P30	Power supply 100-240 VAC/ 24 VDC 20 W	4729 0603
C-32	Power supply repeater for Digiware system	4829 0103

Accessories	Sold in multiples of	Reference
2-pole RM Class CC fuse holder to protect power supply input	6	5705 0002
Digiware Bus terminating resistor (already supplied with DIRIS Digiware C, M & D)	1	4829 0180
6.5-ft USB Cable for configuration - Type A to Type Micro-B	1	4829 0050

Digiware bus cables ⁽¹⁾		Reference
RJ45 cables for Digiware Bus	Length 0.20 ft / 0.06 m	4829 0189
	Length 0.32 ft / 0.10 m	4829 0181
	Length 0.66 ft / 0.20 m	4829 0188
	Length 1.64 ft / 0.50 m	4829 0182
	Length 3.28 ft / 1 m	4829 0183
	Length 6.56 ft / 2 m	4829 0184
	Length 9.84 ft / 3 m	4829 0190
	Length 16.4 ft / 5 m	4829 0186
	Length 32.8 ft / 10 m	4829 0187
	164.04 ft / 50 m reel + 100 connectors	4829 0185

(1) To guarantee the proper operation of the DIRIS Digiware system, do not substitute Socomec Digiware bus cables with standard Ethernet RJ45 cables.

Commissioning		Reference
1/2 day remote commissioning	Remote commissioning including installation verification, programming and communication testing	9230100027
1/2 day on-site commissioning	On-site commissioning including installation verification, programming and communication testing	9230100004

Expert Services

Our service engineers are an essential part of our team, and they are dedicated to ensuring your power monitoring system provides accurate and reliable measurements to your EPMS software or SCADA system.

Our services include:

- > Site audits to verify the proper wiring of your system
- > Personnel training on how to configure, operate and maintain power monitoring equipment and associated software
- > Remote and on-site commissioning to ensure that your system is up and running quickly, with peace of mind.

For further information, please contact your nearest SOCOMEC branch.



DIRIS Digiware C-31

Control and power supply interface



DIRIS Digiware C-31



Function

For applications without a local display, the DIRIS Digiware C-31 interface centralizes the measurements from your Digiware system and communicates data to any external software or PLC via Modbus over RS485. The DIRIS Digiware C-31 interface is supplied with 24 VDC.

Advantages

Compact

Centralize your measurement data on a single module without a local screen, for a complete system:

- Single 24 VDC power supply
- A single RS485 Modbus communication interface

24 VDC Safety Extra Low Voltage power supply

- No dangerous voltage
- The power supply feeds the entire system through the Digiware bus

The solution for

- > Industry
- > Building
- > Data centers
- > Infrastructure



Strong points

- > Compact
- > 24 VDC Safety Extra-Low Voltage power supply

Compliance with standards

- > UL 61010-1
CSA-C22.22
No. 61010-1
Guide FTRZ/PICQ
File E257746



- > IEC 61557-12



- > ISO 14025



Create your project

- > Find the best DIRIS Digiware architecture:

www.meter-selector.com



Dimensions (in/mm)

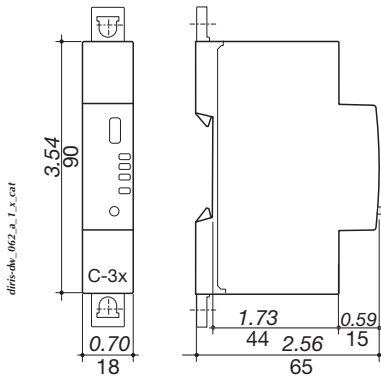

Configuration

Equipment consumption

Product	Power delivered (W)	Power consumed (W)
Power supply		
P15 100-240 VAC / 24 VDC	15	
P30 100-240 VAC / 24 VDC	20	
Digiware Bus cables		
164 feet / 50 meter package		1.5
System interfaces		
DIRIS Digiware D-50/D-70		2.5
DIRIS Digiware M-50/M-70		2.5
DIRIS Digiware C-31		0.8
Voltage Modules		
DIRIS Digiware U-xx		0.72
DIRIS Digiware U-3xdc		0.6
Current Modules		
DIRIS Digiware I-3x		0.52
DIRIS Digiware I-4x		1.125
DIRIS Digiware I-6x		0.7
DIRIS Digiware I-3xdc (+ 3 DC current sensors)		2
DIRIS Digiware S-xx		0.35
DIRIS Digiware BCM		1.25
Input/output modules		
DIRIS Digiware IO-10/IO-20		0.5
Repeater		
DIRIS Digiware C-32		1.5

Repeater

Whenever the power consumption is higher than 20 W or the distance is greater than 328 ft / 100 m, a DIRIS Digiware C-32 repeater is required. In a DIRIS Digiware system, a maximum of 2 repeaters may be used.

Calculation rules for the max. number of products on the Digiware Bus

The total power consumed by the equipment connected to the Digiware Bus must not exceed the power delivered by the 24 VDC supply.

The power supply must not exceed 20 W (for 70 °C / 168 °F ambient temperature) or 27 W (for 40 °F / 104 °F ambient temperature).

Size with P15 power supply (ref: 4829 0120) delivering 15 W

For example, it is possible to use

- 1 DIRIS Digiware D-50 display (2.5 W)
- 1 DIRIS Digiware voltage module U-xx (0.72 W)
- 164 feet / 50 meters of RJ45 cables (1.5 W)

and

- 19 DIRIS Digiware current modules I-3x (19 x 0.52 = 9.9 W)

> Total power = 14.845 W

or

- 9 DIRIS Digiware current modules I-4x (9 x 1.125 = 10.125 W)

> Total power = 14.345 W.

Size with a 24 VDC power supply delivering a maximum of 20 W (Power supply P30 ref: 4729 0603)

For example, it is possible to use

- 1 DIRIS Digiware D-50 display (2.5 W)
- 1 DIRIS Digiware voltage module U-xx (0.72 W)
- 164 feet / 50 meters of RJ45 cables (1.5 W)

and

- 29 DIRIS Digiware current modules I-3x (29 x 0.52 = 15.1 W)

> Total power = 19.82 W

or

- 13 DIRIS Digiware current modules I-4x (13 x 1.125 = 14.625 W)

> Total power = 19.345 W.

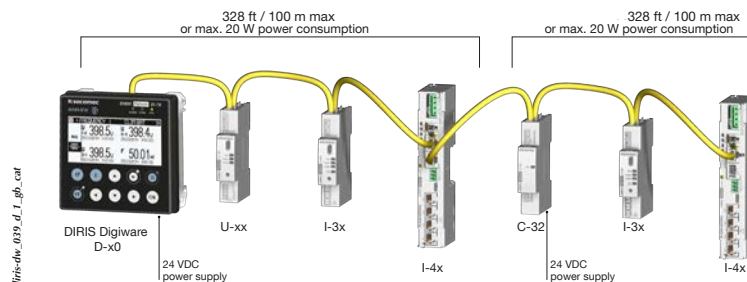

DIRIS Digiware C-31

Control and power supply interface

Connections

DIRIS Digiware C-31

Power supply

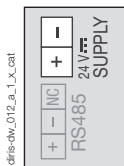

diris-dw_012_a_1_x_cat

Digiware bus



diris-dw_023_b_1_x_cat

Communication

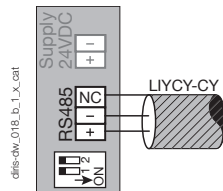

diris-dw_018_b_1_x_cat

DIRIS Digiware C-32

Power supply

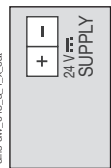

diris-dw_018_a_1_x_cat

Digiware bus

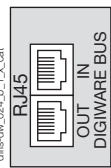

diris-dw_024_b_1_x_cat

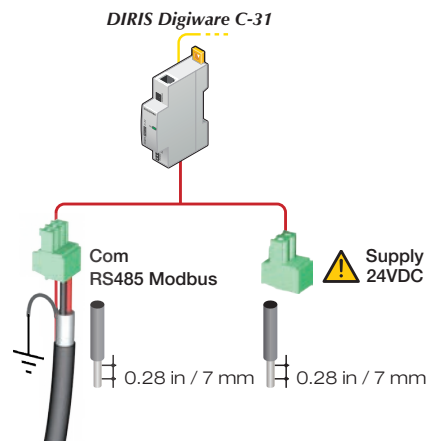

diris-dw_057_a_1_en_cat

Technical characteristics

Mechanical characteristics

Mounting	DIN-rail or back plate
Protection degree	IP40, front face

Electrical characteristics

Power supply	24 VDC \pm 10% - 20 W max
Power consumption	0.8 VA
Connection	Removable screw terminal block, 2 positions, stranded or solid AWG 13 ... AWG 24 or 0.25 ... 2.5 mm ² cable

Environmental characteristics

Storage temperature	-13 ... +158 °F / -25 ... +70°C
Operating temperature	+14 ... +158°F / -10 ... +70°C
Humidity	0% to 97% RH / +131°F/+55°C, non condensing
Operating altitude	≤ 6560 ft / 2000 m

Communication characteristics

Digiware Bus	
Connection type	Socomec RJ45 cable
Function	Proprietary bus connecting Digiware units
RS485	
Connection type	Half-Duplex, 2-3 wires
Protocol	Modbus RTU, configurable as Master or Slave
Baudrate	9600 - 1115200 bds

References

DIRIS Digiware		Reference
C-31	RS485 Modbus RTU system interface	4829 0101

Power supply & repeater		Reference
P15	Power supply 100-240 VAC/ 24 VDC 15 W	4829 0120
P30	Power supply 100-240 VAC/ 24 VDC 20 W	4729 0603
C-32	Power supply repeater for Digiware system	4829 0103

Accessories	Sold in multiples of	Reference
2-pole RM Class CC fuse holder to protect power supply input	6	5705 0002
Digiware Bus terminating resistor (already supplied with DIRIS Digiware C, M & D)	1	4829 0180

Digiware bus cables ⁽¹⁾		Reference
RJ45 cables for Digiware Bus	Length 0.20 ft / 0.06 m	4829 0189
	Length 0.32 ft / 0.10 m	4829 0181
	Length 0.66 ft / 0.20 m	4829 0188
	Length 1.64 ft / 0.50 m	4829 0182
	Length 3.28 ft / 1 m	4829 0183
	Length 6.56 ft / 2 m	4829 0184
	Length 9.84 ft / 3 m	4829 0190
	Length 16.4 ft / 5 m	4829 0186
	Length 32.8 ft / 10 m	4829 0187
	164.04 ft / 50 m reel + 100 connectors	4829 0185

(1) To guarantee the proper operation of the DIRIS Digiware system, do not substitute Socomec Digiware bus cables with standard Ethernet RJ45 cables.

Commissioning		Reference
1/2 day remote commissioning	Remote commissioning including installation verification, programming and communication testing	9230100027
1/2 day on-site commissioning	On-site commissioning including installation verification, programming and communication testing	9230100004

Expert Services

Our service engineers are an essential part of our team, and they are dedicated to ensuring your power monitoring system provides accurate and reliable measurements to your EPMS software or SCADA system.

Our services include:

- > Site audits to verify the proper wiring of your system
- > Personnel training on how to configure, operate and maintain power monitoring equipment and associated software
- > Remote and on-site commissioning to ensure that your system is up and running quickly, with peace of mind.

For further information, please contact your nearest SOCOMEC branch.



DIRIS Digiware U

Voltage measurement module



DIRIS Digiware U-10/U-30



Function

The **DIRIS Digiware U** module is designed to accurately measure voltage for the entire DIRIS Digiware system.

The Digiware RJ45 Bus facilitates the transmission of voltage measurements, power supply, and communication to all connected Digiware modules.

Advantages

Safe

No hazardous voltage on panel doors, as the DIRIS Digiware U module is DIN rail mounted inside the electrical panel.

Flexible

Compatible with all electrical service types up to 520 VAC L-L:

- single phase
- two-phase (with or without neutral)
- three-phase (with or without neutral)

Compact for multi-circuit applications

- A single voltage reference point for the entire DIRIS Digiware system
- Eliminates the need for redundant protective devices, a single protection is needed for the entire system

Comprehensive

A complete solution for metering, monitoring and power quality analysis of the supplied voltage.

The solution for

- > Industry
- > Building
- > Infrastructures
- > Data center



Strong points

- > Safe
- > Compact
- > Flexible
- > Comprehensive

Conformity to standards

- > UL 61010-1, CSA-C22.22 No. 61010-1, Guide FTRZ/PICQ, File E257746



- > IEC 61557-12



- > ISO 14025



Create your project

- > Find the best DIRIS Digiware configuration:
www.meter-selector.com



Application	Voltage measurement module	
	Metering	Analysis
		
DIRIS Digiware U	U-10	U-30
Electrical		
Voltage Measurement	50 - 300 VAC L-N 87 - 520 VAC L-L	50 - 300 VAC L-N 87 - 520 VAC L-L
Multi-measurement		
U12, U23, U31, V1, V2, V3, f	•	•
U system, V system		•
Unbalance U, V		•
Power Quality		
THD U, V		•
Individual Harmonics U, V (up to 63rd)		•
PQ Events (sags, swells, interruptions)		•
Waveform capture		
Alarms		
Measurement Threshold		•
System alarms	•	•
History		
Average values		•

Dimensions (in/mm)

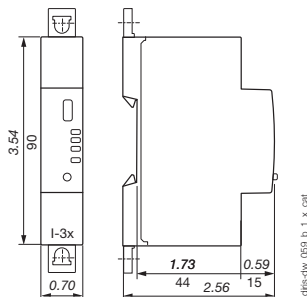

Technical Characteristics

Mechanical characteristics	
Mounting type	DIN-rail or back plate
Ingress protection	IP20, front face
Electrical characteristics	
Voltage range	50-300 VAC (Ph/N) - 87-520 VAC (Ph/Ph) - CAT III
Permanent overload	300 VAC (Ph/N)
Electrical Network (Service) type	Single-Phase - Two-Wire, Line-to-Neutral Single-Phase - Two-Wire, Line-to-Line Single-Phase - Three-Wire (Split-Phase) Three-Phase - Three-Wire (Delta) Three-Phase - Four-Wire (Wye) Three-Phase - Four-Wire High-Leg Delta
Frequency range	45 ... 65 Hz
Input consumption	≤ 0.1 VA
Connection	Removable screw terminal block, 4 positions, AWG 14 ... AWG 24 / 0.25 ... 2.5 mm ² solid cable or stranded cable with ferrule

Measurement characteristics	
Sampling rate	9.6 kHz
Voltage measurement accuracy	Class 0.2
Frequency measurement accuracy	Class 0.02
Communication characteristics	
Digiware Bus	
Connection type	Socomec RJ45 cable
Function	Proprietary bus connecting Digiware units
USB	
Connection type	USB Type Micro-B
Protocol	Modbus RTU over USB
Function	Firmware upgrade and configuration
Environmental characteristics	
Storage temperature	-4 to +158 °F / -20 to +70°C
Operating temperature	+14 to +158 °F / -10 to +70°C
Humidity	0% to 97% RH / +131°F/+55°C, non condensing
Operating altitude	≤ 6560 ft / 2000 m

References

DIRIS Digiware U		Reference
U-10	Basic - voltage measurement	4829 0105
U-30	Analysis - power quality and alarming	4829 0102

Accessories	To be ordered in multiples of	Reference
3-pole RM Class CC fuse holder to protect voltage inputs	4	5705 0003
Digiware Bus terminating resistor (already supplied with DIRIS Digiware C, M & D)	1	4829 0180
6.5-ft USB Cable for configuration - Type A to Type Micro-B	1	4829 0050

Digiware bus cables ⁽¹⁾	Reference
Length 0.20 ft / 0.06 m	4829 0189
Length 0.32 ft / 0.10 m	4829 0181
Length 0.66 ft / 0.20 m	4829 0188
Length 1.64 ft / 0.50 m	4829 0182
Length 3.28 ft / 1 m	4829 0183
Length 6.56 ft / 2 m	4829 0184
Length 9.84 ft / 3 m	4829 0190
Length 16.4 ft / 5 m	4829 0186
Length 32.8 ft / 10 m	4829 0187
164.04 ft / 50 m reel + 100 connectors	4829 0185

(1) To guarantee the proper operation of the DIRIS Digiware system, do not substitute Socomec Digiware bus cables with standard Ethernet RJ45 cables.

DIRIS Digiware S

Current measurement module with integrated sensors



DIRIS Digiware S



Function

DIRIS Digiware S current acquisition modules have 3 integrated current sensors for measuring, monitoring, and analyzing electrical circuits up to 63 A.

Positioned directly downstream protective devices, they offer exclusive technologies: VirtualMonitor which provides real time status of protective devices (ON/OFF/TRIP).

AutoCorrect which detects wiring errors even under no load-conditions, and enables software correction without the hassle of reworking the physical wiring.

Multiple DIRIS Digiware S modules can be daisy chained by simply clicking in an RJ45 cable. This allows great flexibility to the user who wishes to add more metering points in the future.

Advantages

Plug & Play

- Save wiring time: the current sensors are integrated in the module
- Quick RJ45 connection between modules
- Direct mounting, upstream or downstream of the protective device

Multi-circuit

Multiple DIRIS Digiware S modules can be daisy chained to monitor multiple loads

Compact

- The best compactness/performance ratio on the market
- Current inputs spaced at 3/4" center intervals, aligning perfectly with protective devices

Accurate

- Class 0.5 for active energy (kWh) from 2 - 120% of nominal current

The solution for

- > Data center
- > Building
- > Industry

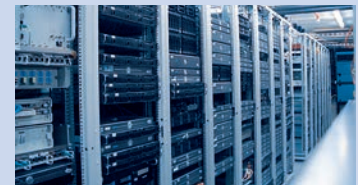

Strong points

- > Plug & Play
- > Multi-circuit
- > Compact
- > Accurate

Integrated technologies



For more information see our website www.socomec.us

Conformity to standards

- > UL 61010-1
CSA-C22.22
No. 61010-1
Guide FTRZ/PICQ
File E257746



- > IEC 61557-12

- > ISO 14025





Create your project

- > Find the best DIRIS Digiware configuration:

www.meter-selector.com



Application	Current measurement module with integrated sensors	
	Metering	Analysis
		
	S-130	S-135
DIRIS Digiware S		
General		
Number of integrated sensors	3	3
Maximum current for integrated sensors	63 A	63 A
Breaker pitch / center spacing	18 mm	18 mm
Metering		
± kWh, ± kvarh, kVAh	•	•
ΣP (kW), ΣQ (kvar), ΣS (kVA), PF	•	•
P (kW), Q (kvar), S (kVA), PF per phase		•
Predictive Power		•
Load curves / demand profiles		•
Peak Demand		•
Multi-tariff (max 8)	•	•
Multi-measurement		
I1, I2, I3, In	•	•
I system		•
Current unbalance (Inba, Idir, linv, Ihom, Inb)		•
Phi, cos Phi, tan Phi	•	•
Power Quality		
THD I1, I2, I3, In		•
Individual harmonics I (up to 63rd)		•
Crest factors I1, I2, I3, In		•
K Factor		•
Alarms		
Overcurrents		•
Measurement thresholds		•
System alarms	•	•
Protective device	•	•
History		
Average values		•
Reference	4829 0160	4829 0161

Mounting accessories

Temporary MCB insert
(for use during panel assembly)



DIN rail and back plate mounting

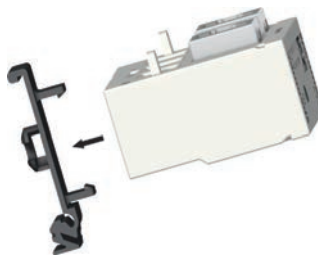

Cable tie



DIRIS Digiware S

Current measurement module with integrated sensors

Dimensions (in/mm)

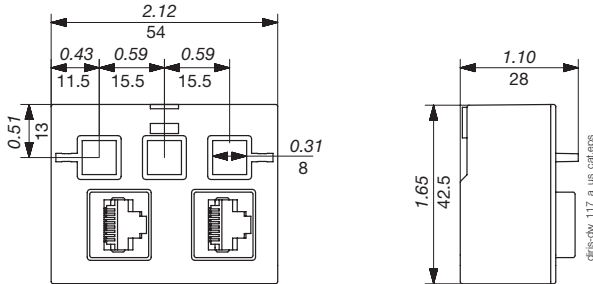

Connections

Current is measured by the integrated inputs I01, I02 and I03 on the DIRIS Digiware S module.

3P+N - 3CT

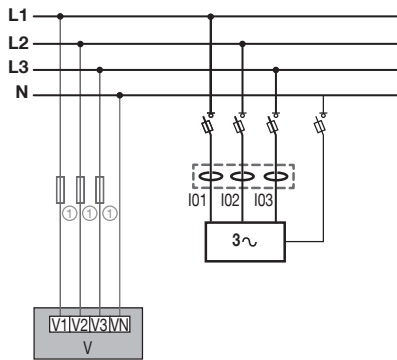

3P - 3 CT

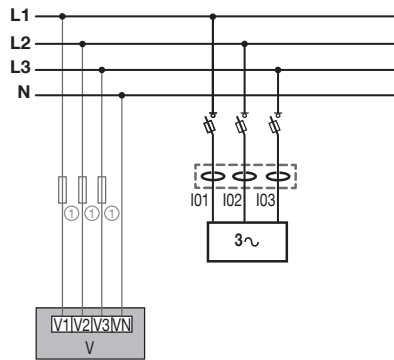

2P+N - 2CT & 2P+N - 1CT

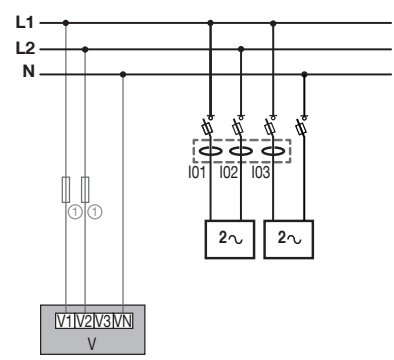

1P+N - 1 CT (3x)

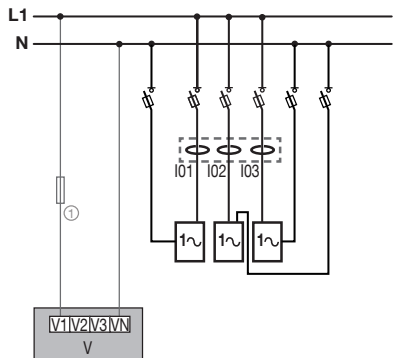

3P+N - 1 CT (3x)

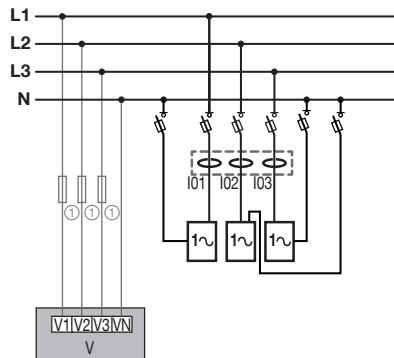

2P+N - 1 CT (3x)

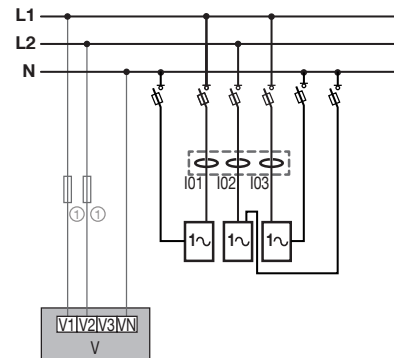

DIRIS Digiware S

3~ Load

Fuses: 0.5 A gG/BS 88 2 A gG/0.5 A class CC

Technical characteristics

Measurement characteristics

Measurement of current	
Number of current inputs	3
Associated current sensors	Integrated in the product
Basic current I _b	10 A
Maximum current I _{max}	63 A
Current measurement accuracy	Class 0.5 IEC 61557-12

Measurement of energy

Accuracy of active energy	Class 0.5 IEC 61557-12
Accuracy of reactive energy	Class 1 IEC 61557-12

Mechanical characteristics

Mounting	DIN rail or back plate
Protection degree	IP20, front face
Power consumption	0.35 VA

Communication characteristics

Digiware Bus	
Connection type	Socomec RJ45 cable
Function	Proprietary bus connecting Digiware units
USB	
Connection type	USB Type Micro-B
Protocol	Modbus RTU over USB
Function	Firmware upgrade and configuration

Environmental characteristics

Operating temperature	+14 ... +131 °F / -10 ... +55 °C
Storage temperature	-13 ... +158 °F / -25 ... +70 °C
Operating humidity	0% to 97% RH / +131 °F / 55 °C, non condensing
Operating altitude	≤ 6560 feet / 2000 m

References

DIRIS Digiware S		Reference
S-130	Metering - 3 integrated current sensors	4829 0160
S-135	Analysis - 3 integrated current sensors	4829 0161

Accessories		Reference
DIN rail mounting clips (10 pieces)		4829 0195
Temporary MCB insert		4829 0196
Digiware Bus terminating resistor (already supplied with DIRIS Digiware C, M & D)		4829 0180
6.5-ft USB Cable for configuration - Type A to Type Micro-B		4829 0050

Digiware bus cables ⁽¹⁾		Reference
RJ45 cables for Digiware Bus	Length 0.20 ft / 0.06 m	4829 0189
	Length 0.32 ft / 0.10 m	4829 0181
	Length 0.66 ft / 0.20 m	4829 0188
	Length 1.64 ft / 0.50 m	4829 0182
	Length 3.28 ft / 1 m	4829 0183
	Length 6.56 ft / 2 m	4829 0184
	Length 9.84 ft / 3 m	4829 0190
	Length 16.4 ft / 5 m	4829 0186
	Length 32.8 ft / 10 m	4829 0187
	164.04 ft / 50 m reel + 100 connectors	4829 0185

(1) To guarantee the proper operation of the DIRIS Digiware system, do not substitute Socomec Digiware bus cables with standard Ethernet RJ45 cables.

Commissioning		Reference
1/2 day remote commissioning	Remote commissioning including installation verification, programming and communication testing	9230100027
1/2 day on-site commissioning	On-site commissioning including installation verification, programming and communication testing	9230100004

Expert Services

Our service engineers are an essential part of our team, and they are dedicated to ensuring your power monitoring system provides accurate and reliable measurements to your EPMS software or SCADA system.

Our services include:

- > Site audits to verify the proper wiring of your system
- > Personnel training on how to configure, operate and maintain power monitoring equipment and associated software
- > Remote and on-site commissioning to ensure that your system is up and running quickly, with peace of mind.

For further information, please contact your nearest SOCOMEC branch.



DIRIS Digiware BCM

Branch-circuit monitoring strip with integrated current sensors



DIRIS Digiware BCM 21 circuits, 1 in. pitch



DIRIS Digiware BCM 21 circuits, 3/4 in. pitch

The solution for

- > Data center
- > High rises
- > Commercial Buildings



Strong points

- > 3x quicker to install than standard solutions
- > 2x quicker to configure than standard solutions
- > Minimal footprint
- > Maximum reliability

Conformity to standards

- > UL 61010-1
CSA-C22.22 No. 61010-1
Guide FTRZ/PICQ
File E257746
- > ANSI C12.20
- > IEC 61557-12



Integrated technologies



For more information see our website www.socomec.us

Create your project

- > Find the best DIRIS Digiware configuration:
www.meter-selector.com



Function

The DIRIS Digiware BCM is a multi-circuit metering strip with 21 integrated sensors and allows individual circuit monitoring within any of any electrical panelboard (Remote Power Panel, lighting panel, power panel etc.). The DIRIS Digiware BCM is also equipped with three RJ12 channels connected to TE/TR/ITR/TF current sensors and ΔIC zero sequence CTs.

Advantages

3x quicker to install than standard solutions

- The integrated current sensors do not require any wiring: they are directly integrated to the BCM meter strip.
- Quick RJ45 connection between modules.
- RJ12 connection for external current sensors.
- AutoCorrect technology detects wiring errors, even off-load.

2x quicker to configure than standard solutions

Easy Config System Software - free of charge – enables the configuration of multiple identical panels with a “duplication” function and also provides time-saving configuration templates enabling the initial design to be adapted with ease.

Minimal footprint





- No additional CT leads required - and therefore less cabling required.
- VirtualMonitor technology indicating breaker status eliminates the need to install auxiliary contacts.
- Connection to TE/TR/ITR/TF current sensors and ΔIC zero sequence CTs to mutualize power metering and earth leakage monitoring.

Maximum reliability

- A robust protective plastic cover safeguards the electronic components and reduces the risk of breakage. By not simply being an exposed PCB, the unit can, therefore, be handled manually.
- PreciSense technology ensures accurate and reliable measurements over a wide measurement range: class 0.5 accuracy for active energy according to IEC 61557-12 and ANSI C12.20 standards.
- Integrated VirtualMonitor technology to access individual breaker status remotely and in real-time.

General Characteristics

- 21 integrated current sensors.
- Measures up to 120 A.
- 3/4-in and 1-in pitch versions
- Configurable as 21 single-phase circuits, 7 three-phase circuits or a mix of single-phase, two-phase and three-phase circuits.

DIRIS Digiware BCM	BCM-2119	BCM-2119VM	BCM-2125	BCM-2125VM
				
Number of current inputs	21 + 3x RJ12	21 + 3x RJ12	21 + 3x RJ12	21 + 3x RJ12
Nominal current I _n / Maximum current I _{max}	32...63A/80A	32...63A/80A	40...100A/120A	40...100A/120A
Load type accepted	1P+N 2P 2P+N 3P 3P+N	1P+N 2P 2P+N 3P 3P+N	1P+N 2P 2P+N 3P 3P+N	1P+N 2P 2P+N 3P 3P+N
General				
Number of integrated sensors	21	21	21	21
Maximum current for integrated sensors	80 A	80 A	120 A	120 A
Number of external RJ12 sensor inputs (allows to connect TE, TR/iTR, TF sensors)	3	3	3	3
Breaker pitch / center spacing	19 mm	19 mm	25 mm	25 mm
Metering				
± kWh, ± kvarh, kVAh	•	•	•	•
ΣP (kW), ΣQ (kvar), ΣS (kVA), PF	•	•	•	•
P (kW), Q (kvar), S (kVA), PF per phase	•	•	•	•
Predictive Power	•	•	•	•
Load curves / demand profiles	•	•	•	•
Peak Demand	•	•	•	•
Multi-tariff (max 8)	•	•	•	•
Multi-measurement				
I ₁ , I ₂ , I ₃ , I _n	•	•	•	•
I system	•	•	•	•
Current unbalance (I _{nba} , I _{dir} , I _{inv} , I _{hom} , I _{nb})	•	•	•	•
Phi, cos Phi, tan Phi	•	•	•	•
Power Quality				
THD I ₁ , I ₂ , I ₃ , I _n	•	•	•	•
Individual harmonics I (up to 63rd)	•	•	•	•
Crest factors I ₁ , I ₂ , I ₃ , I _n	•	•	•	•
K Factor	•	•	•	•
Ground leakage current monitoring	•	•	•	•
Alarms				
Overcurrents	•	•	•	•
Measurement thresholds	•	•	•	•
System alarms	•	•	•	•
Protective device		•		•
History				
Average values	•	•	•	•
Advanced features				
VirtualMonitor technology		•		•
AutoCorrect technology	•	•	•	•
Earth leakage monitoring	•	•	•	•
Reference	4829 0167	4829 0168	4829 0169	4829 0170

DIRIS Digiware BCM

Branch-circuit monitoring module with integrated current sensors

Mounting accessories

Back plate mounting

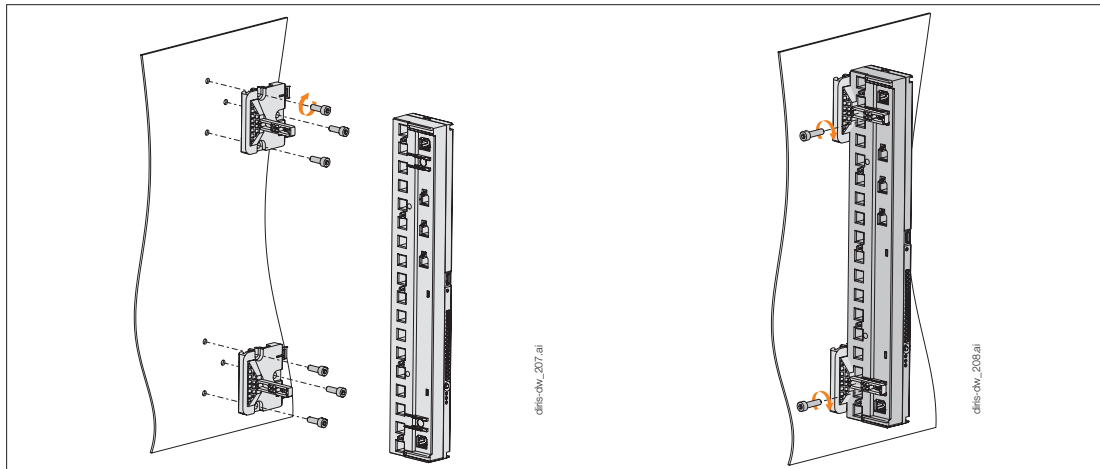

DIN rail mounting

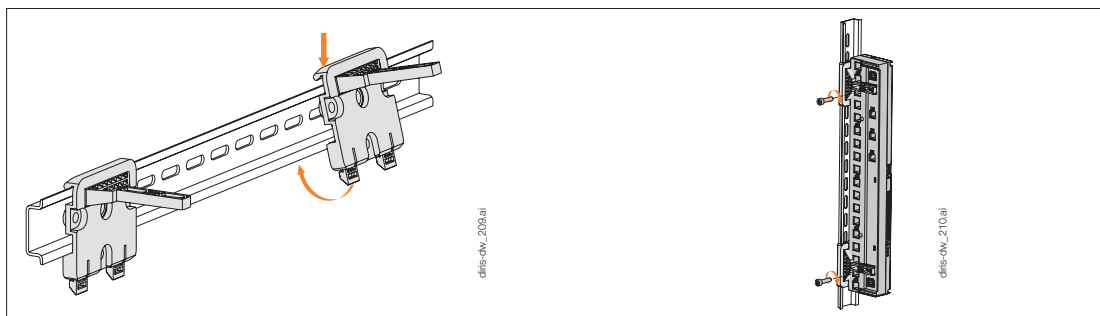

(1) 2x mounting brackets along with 2 x CHC M5 x 20 screws are included with the DIRIS Digiware BCM modules.

Dimensions (in/mm)

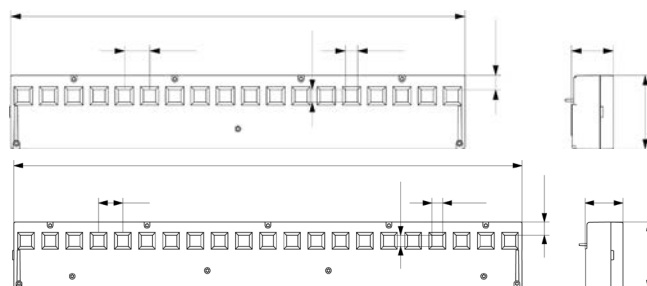

Model	A		B		C		D		E		F		G	
	(in)	(mm)	(in)	(mm)	(in)	(mm)	(in)	(mm)	(in)	(mm)	(in)	(mm)	(in)	(mm)
DIRIS Digiware BCM-2119 / 2119VM	15.75	400	0.75	19	0.35	8.8	0.34	8.6	0.39	10	1.18	30	2.09	53
DIRIS Digiware BCM-2125 / 2125VM	20.98	533.5	0.98	25	0.55	14	0.54	13.6	0.75	19	1.26	32	2.68	68

Connections

DIRIS Digiware BCM-21xx

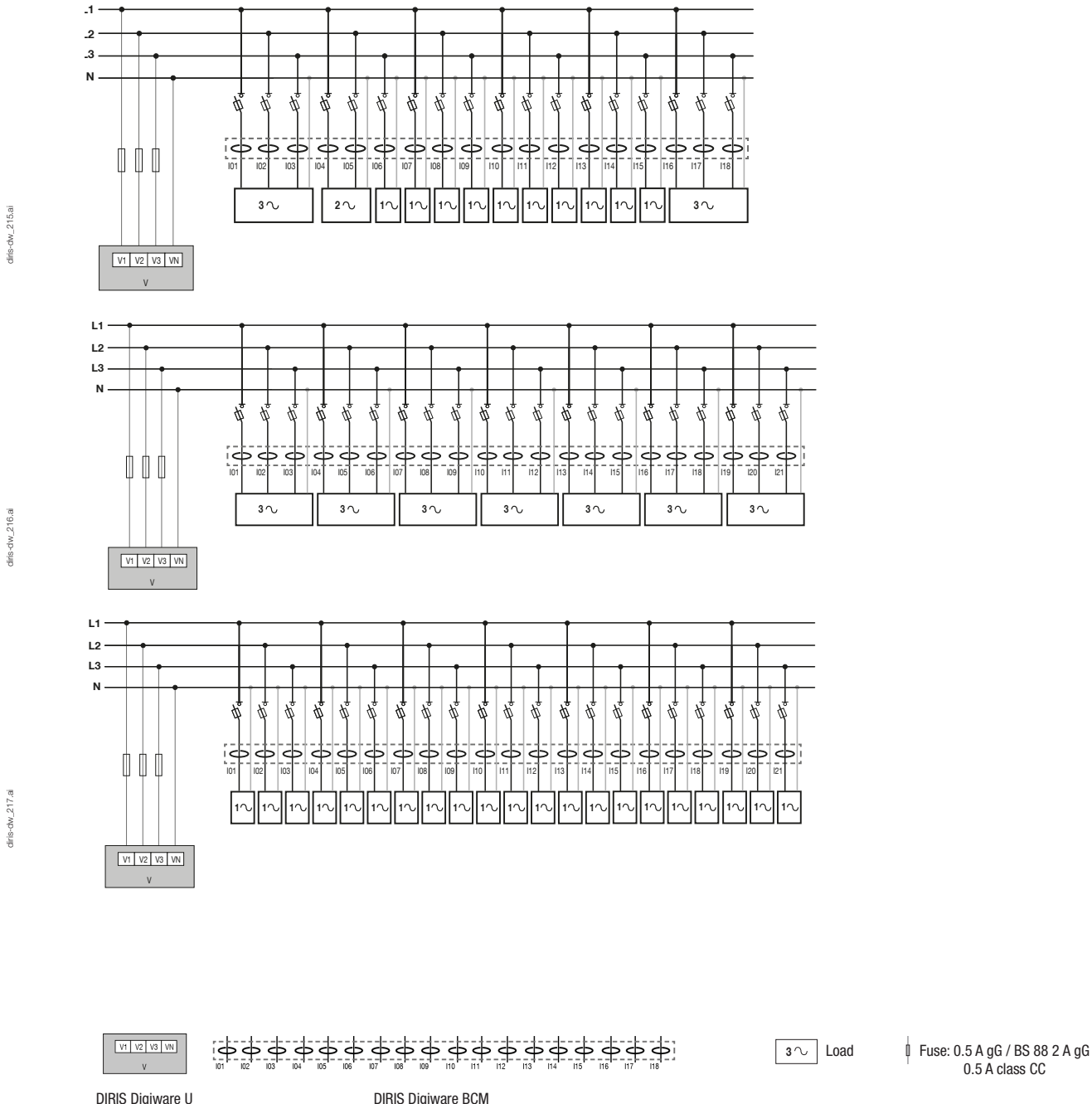

Technical Characteristics

Mechanical characteristics

Mounting type	DIN-rail or back plate
Ingress Protection	IP20

Measurement characteristics

Current measurement	DIRIS Digiware BCM-2119	DIRIS Digiware BCM-2125
Number of integrated current inputs	21	21
Nominal current - integrated current sensors	32 ... 63 A	40 ... 100 A
Maximum current - integrated current sensors	80 A	120 A
Number of RJ12 current inputs	3	3
Associated current sensors (RJ12 current inputs)	Solid-core TE, split-core TR/ITR, flexible TF current sensors	
Connection type	Socomec RJ12 cables	
Current measurement accuracy - integrated current sensors	Class 0.5	
Current measurement accuracy - RJ12 current inputs	Class 0.2 DIRIS Digiware BCM alone Class 0.5 with TE, ITR or TF sensors Class 1 with TR sensors	
Energy measurement		
Active Energy accuracy - integrated current sensors	Class 0.5	
Active Energy accuracy - RJ12 current inputs	Class 0.2 DIRIS Digiware BCM alone Class 0.5 with TE, ITR, TF sensors Class 1 with TR sensors	
Reactive Energy accuracy - integrated current sensors	Class 1	
Reactive Energy accuracy - RJ12 current inputs	Class 1 with TE, ITR, TF sensors Class 2 with TR sensors	

Communication characteristics

Digiware bus	
Connection type	Socomec RJ12 cable
Function	Proprietary bus connecting Digiware units
USB	
Connection type	USB Type Micro-B
Protocol	Modbus RTU over USB
Function	Firmware upgrade and configuration

Environmental characteristics

Storage temperature	-40 ... +158°F / -40 ... +70°C
Operating temperature	+14 to +131 °F / -10 to +55°C
Humidity	0% to 97% RH / +131°F / +55°C, non condensing
Operating altitude	≤ 6560 ft / 2000 m

References

DIRIS Digiware BCM		Reference
BCM-2119	21 current inputs (19 mm / 3/4 in pitch)	4829 0167
BCM-2119VM	21 current inputs (19 mm / 3/4 in pitch) + Virtual Monitor	4829 0168
BCM-2125	21 current inputs (25 mm / 1 in pitch)	4829 0169
BCM-2125VM	21 current inputs (25 mm / 1 in pitch) + Virtual Monitor	4829 0170

Accessories		Reference
BCM-2119 DIN-rail brackets (2 pieces) ⁽¹⁾		4829 0197
BCM-2115 DIN-rail brackets (2 pieces) ⁽¹⁾		4829 0198
Digiware Bus terminating resistor (already supplied with DIRIS Digiware C, M & D)		4829 0180
6.5-ft USB Cable for configuration - Type A to Type Micro-B		4829 0050

(1) 2 DIN-rail brackets are already supplied with the DIRIS Digiware BCM meter

Digiware bus cables ⁽²⁾		Reference
RJ45 cables for Digiware Bus	Length 0.20 ft / 0.06 m	4829 0189
	Length 0.32 ft / 0.10 m	4829 0181
	Length 0.66 ft / 0.20 m	4829 0188
	Length 1.64 ft / 0.50 m	4829 0182
	Length 3.28 ft / 1 m	4829 0183
	Length 6.56 ft / 2 m	4829 0184
	Length 9.84 ft / 3 m	4829 0190
	Length 16.4 ft / 5 m	4829 0186
	Length 32.8 ft / 10 m	4829 0187
164.04 ft / 50 m reel + 100 connectors		4829 0185

(2) To guarantee the proper operation of the DIRIS Digiware system, do not substitute Socomec Digiware bus cables with standard Ethernet RJ45 cables.

Commissioning		Reference
1/2 day remote commissioning	Remote commissioning including installation verification, programming and communication testing	9230100027
1/2 day on-site commissioning	On-site commissioning including installation verification, programming and communication testing	9230100004

Expert Services

Our service engineers are an essential part of our team, and they are dedicated to ensuring your power monitoring system provides accurate and reliable measurements to your EPMS software or SCADA system.

Our services include:

- > Site audits to verify the proper wiring of your system
- > Personnel training on how to configure, operate and maintain power monitoring equipment and associated software
- > Remote and on-site commissioning to ensure that your system is up and running quickly, with peace of mind.

For further information, please contact your nearest SOCOMEC branch.



DIRIS Digiware I

Current acquisition module

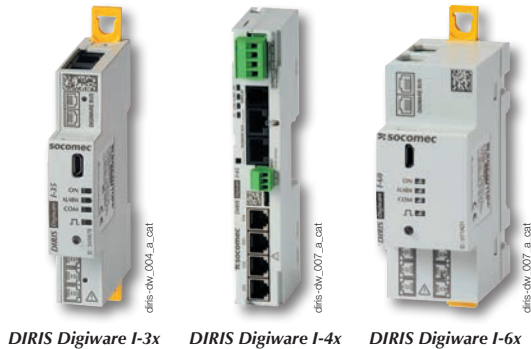

Function

DIRIS Digiware I are DIN-rail mounted power monitoring modules. Associated with DIRIS Digiware U modules, they measure and monitor electrical parameters such as powers, energies and power quality of electrical installations.

The modularity, along with the RJ45 Digiware Bus provides a unique multi-circuit and scalable approach. Adding DIRIS Digiware I modules to the bus is done simply by clicking in an RJ45 cable. This allows great flexibility to users who wish to add more metering points in the future.

The RJ12 current inputs allow a quick and error-free connection to current sensors (TE, TR/iTR, TF) with automatic detection of the type and rating of the current sensors connected. This ensures reliable and accurate measurements at all times.

Advantages

Multi-circuit

- One module can monitor up to 2 three-phase circuits.
- Up to 31 current measurement modules can be added to the Digiware Bus, allowing to monitor a large number of circuits within the same DIRIS Digiware system.

Plug & Play

- RJ45 cables for a quick and easy connection of modules.
- Color-coded RJ12 cables to connect current sensors, quickly, safely and without errors.
- Load type, current sensor type and rating are automatically detected.
- When connected to iTR current sensors, the AutoCorrect technology detects and corrects wiring errors, making the system more reliable.

Accurate

- Compliant with standard IEC 61557-12, guaranteeing the quality and accuracy of measurements:
- class 0.5 from 2 - 120% In for the global measurement chain (including TE/ iTR/TF current sensors)
- class 1 from 2 - 120% In for the global measurement chain (including TR current sensors)

Flexible

- Modules available in 3, 4 or 6 current sensor inputs.
- The types of current modules can be mixed within the Digiware system, to monitor a variety of single-phase, two-phase and three-phase circuits.

The solution for

- > Industry
- > Building
- > Infrastructure
- > Data center



Strong points

- > Multi-circuit
- > Plug & Play
- > Accurate
- > Flexible

Integrated technologies



For more information see our website www.socomec.us

Conformity to standards







- > UL 61010-1, CSA-C22.22 No. 61010-1, Guide FTRZ/PICQ, File E257746
- > ANSI C12.20
- > PBI Meter per CA Energy Commission
- > IEC 61557-12



Create your project

- > Find the best DIRIS Digiware configuration: www.meter-selector.com



Application	Current measurement modules						
	Metering		Analysis	Monitoring	Analysis	Metering	
							
DIRIS Digiware I	I-30	I-31	I-35	I-43	I-45	I-60	I-61
General							
Number of current inputs	3	3	3	4	4	6	6
Inputs / Outputs							
Digital inputs / outputs				2 / 2	2 / 2		
Metering							
± kWh, ± kvarh, kVAh	•	•	•	•	•	•	•
ΣP (kW), ΣQ (kvar), ΣS (kVA), PF	•	•	•	•	•	•	•
P (kW), Q (kvar), S (kVA), PF per phase		•	•	•	•		•
Predictive Power			•		•		
Load curves / demand profiles		•	•		•		•
Peak Demand			•	•	•		
Multi-tariff			8		8		
Multi-measurement							
I1, I2, I3, In	•	•	•	•	•	•	•
I system			•		•		
Current unbalance (Inba, Idir, linv, Ihom, Inb)			•		•		
Phi, cos Phi, tan Phi			•		•		
Power Quality							
THD I1, I2, I3, In			•	•	•		
Individual harmonics 1 (up to 63rd)			•		•		
Crest factors I1, I2, I3, In			•		•		
K Factor			•		•		
I/O							
Digital Inputs							
Digital Outputs							
Alarms							
Overcurrents			•		•		
Measurement threshold		Power / Energies	•		•		Power / Energies
System alarms	•	•	•	•	•	•	•
Protective device	with ITR sensors	with ITR sensors	with ITR sensors	with ITR sensors	with ITR sensors	with ITR sensors	with ITR sensors
Logical (digital input status change)				•	•		
History							
Average values			•		•		
Reference	4829 0110	4829 0111	4829 0130	4829 0129	4829 0131	4829 0112	4829 0113

Accessories

Digiware plug-in connector

With the Digiware plug-in connector you can disconnect a DIRIS Digiware module from the Digiware bus while ensuring the DIRIS Digiware system continues to run downstream.

This accessory is particularly useful in applications with retractable drawers or critical applications such as data centers with busway systems.



diris-e-0215.eps

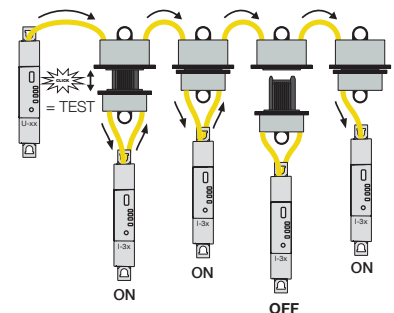

diris-e-0216_a1_caf.fr

Dimensions (in/mm)

DIRIS Digiware I-3x / I-6x

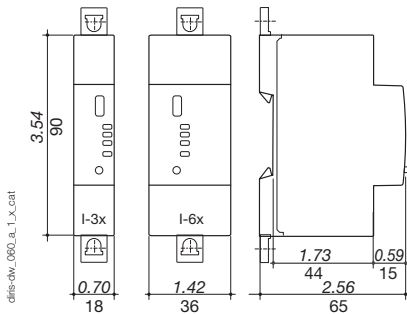

DIRIS Digiware I-4x

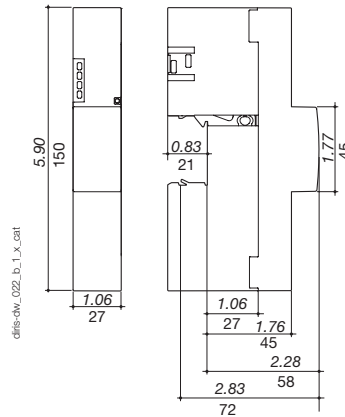

Current sensors

Various types of current sensors can be connected to the DIRIS Digiware I: Solid-core TE, split-core TR/TR, flexible TF current sensors. This range of sensors can be adapted to all types of new or existing installations. A rapid RJ12 connection makes wiring easy and reliable and prevents wiring errors. The DIRIS Digiware I meter module automatically recognizes the type of sensor used and its current rating. This guarantees the accuracy of the overall measurement chain (DIRIS Digiware I + current sensors).

For more information see "TE, TR and TF sensors" pages.

I-3x

Three-phase

3P - 3CT (1 three-phase load)

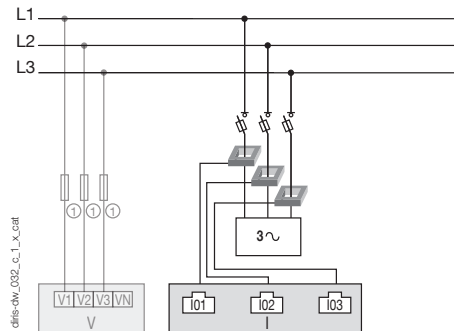

Three-phase

3P - 1CT (3 balanced, three-phase loads)

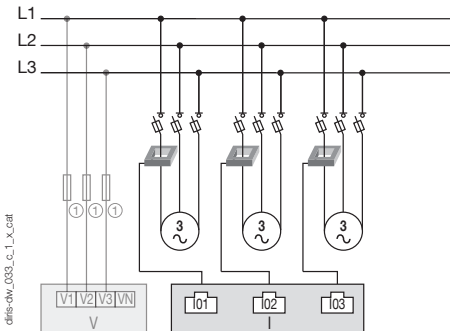

I-4x

Three phase + neutral

3P+N - 4CT (1 three-phase load + Neutral measured)

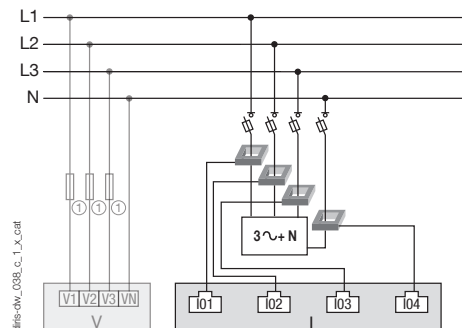

Single-phase

1P+N-1CT (4 single-phase loads)

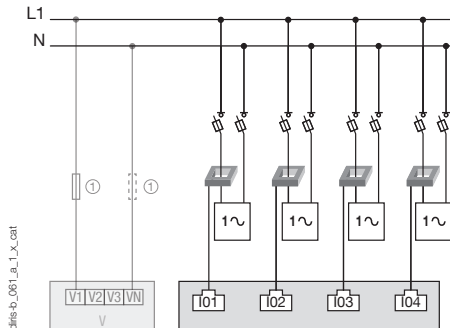

1. 0.5 A gG / 0.5 A class CC fuses.

CT: Current sensor 3~ Load

Technical Characteristics

Mechanical characteristics	
Mounting type	DIN-rail or back plate
Ingress Protection	IP20, front face

Measurement characteristics	
Current measurement	
Number of current inputs	I-3x: 3 / I-45: 4 / I-6x: 6
Associated current sensors	Solid-core TE, split-core TR/iTR, flexible TF current sensors
Connection type	Socomec RJ12 cables
Current measurement accuracy	Class 0.2 DIRIS Digiware I alone Class 0.5 with TE, iTR, TF sensors Class 1 with TR sensors

Power and Energy measurement	
Active Power/Energy accuracy	Class 0.2 DIRIS Digiware I alone Class 0.5 with TE, iTR, TF sensors Class 1 with TR sensors
Reactive Power accuracy	Class 1 with TE, iTR, TF sensors Class 2 with TR sensors
Reactive Energy accuracy	Class 2 with TE, TR/iTR, TF sensors

Digital inputs - DIRIS Digiware I-4x	
Number of digital inputs	2
Digital input type	Non-insulated input, internal polarization 12 VDC max, 1mA
Function	Logical status, pulse meter, multi-tariff
Connection	Removable screw terminal block, 4 positions, AWG 16 to AWG 26 / 0.2 to 1.5 mm ² stranded or solid cable

Digital outputs - DIRIS Digiware I-4x	
Number of digital outputs	2
Relay type	230 VAC ±15% - 1 A 30 VDC - 3 A
Function	Manual command, alarm report
Connection	Removable screw terminal block, 4 positions, AWG 14 to AWG 24 / 0.2 to 2.5 mm ² stranded or solid cable

Communication characteristics	
Digiware Bus	
Connection type	Socomec RJ45 cable
Function	Proprietary bus connecting Digiware units
USB	
Connection type	USB Type Micro-B
Protocol	Modbus RTU over USB
Function	Firmware upgrade and configuration

Environmental characteristics	
Storage temperature	-4 to +158 °F / -20 to +70°C
Operating temperature	+14 to +158 °F / -10 to +70°C
Humidity	0% to 97% RH / +131°F/+55°C, non condensing
Operating altitude	≤ 6560 ft / 2000 m

References

DIRIS Digiware I	Reference
I-30 Metering - 3 current inputs	4829 0110
I-31 Metering + demand profiles - 3 current inputs	4829 0111
I-35 Analysis - 3 current inputs	4829 0130
I-43 Monitoring - 2 inputs/ 2 outputs - 4 current inputs	4829 0129
I-45 Analysis - 2 inputs/ 2 outputs - 4 current inputs	4829 0131
I-60 Metering - 6 current inputs	4829 0112
I-61 Metering + demand profiles - 6 current inputs	4829 0113

Accessories	Reference
Digiware Plug-in connectors (box of 5)	4829 0605
Digiware Bus terminating resistor (already supplied with DIRIS Digiware C, M & D)	4829 0180
1A/5A secondary CT adapter with RJ12 output	4829 0599
6.5-ft USB Cable for configuration - Type A to Type Micro-B	4829 0050

Digiware bus cables ⁽¹⁾	Reference	
RJ45 cables for Digiware Bus	Length 0.20 ft / 0.06 m	4829 0189
	Length 0.32 ft / 0.10 m	4829 0181
	Length 0.66 ft / 0.20 m	4829 0188
	Length 1.64 ft / 0.50 m	4829 0182
	Length 3.28 ft / 1 m	4829 0183
	Length 6.56 ft / 2 m	4829 0184
	Length 9.84 ft / 3 m	4829 0190
	Length 16.4 ft / 5 m	4829 0186
Length 32.8 ft / 10 m	4829 0187	
164.04 ft / 50 m reel + 100 connectors	4829 0185	

⁽¹⁾ To guarantee the proper operation of the DIRIS Digiware system, do not substitute Socomec Digiware bus cables with standard Ethernet RJ45 cables.

References (continued)

RJ12 Solid-core current sensors ⁽¹⁾

Model	Nominal current range (A)	Real range covered (A)	Window size (in/mm)	Reference
TE-18	5 ... 20	0.1 ... 24	∅ 0.33 / 8.6	4829 0500
TE-18	25 ... 63	0.5 ... 75	∅ 0.33 / 8.6	4829 0501
TE-25	40 ... 160	0.8 ... 192	0.53 x 0.53 / 13.5 x 13.5	4829 0502
TE-35	63 ... 250	1.26 ... 300	0.82 x 0.82 / 21 x 21	4829 0503
TE-45	160 ... 630	3.2 ... 756	1.22 x 1.22 / 31 x 31	4829 0504
TE-55	400 ... 1000	8 ... 1200	1.61 x 1.61 / 41 x 41	4829 0505
TE-90	600 ... 2000	12 ... 2400	2.52 x 2.52 / 64 x 64	4829 0506

(1) Refer to pages 348-351 for more information on TE current sensors

RJ12 Split-core current sensors ⁽²⁾

Model	Nominal current range (A)	Real range covered (A)	Window size (in/mm)	Reference
TR-10 / iTR-10	25 ... 63	0.5 ... 75.6	∅ 0.39 / 10	4829 0555 / 4829 0655
TR-14 / iTR-14	40 ... 160	0.8 ... 192	∅ 0.55 / 14	4829 0556 / 4829 0656
TR-21 / iTR-21	63 ... 250	1.26 ... 300	∅ 0.83 / 21	4829 0557 / 4829 0657
TR-32 / iTR-32	160 ... 600	3.2 ... 720	∅ 1.26 / 32	4829 0558 / 4829 0658

(2) Refer to pages 352-353 for more information on TR/iTR current sensors

RJ12 Flexible Rogowski current sensors ^{(3) (4)}

Model	Nominal current range (A)	Real range covered (A)	Window size (in/mm)	Reference
TF-40	100 ... 400	2 ... 480	∅ 1.57 / 40	4829 0573
TF-80	150 ... 600	3 ... 720	∅ 3.15 / 80	4829 0574
TF-120	400 ... 2000	8 ... 2400	∅ 4.72 / 120	4829 0575
TF-200	600 ... 4000	12 ... 4800	∅ 7.87 / 200	4829 0576
TF-300	1600 ... 6000	32 ... 7200	∅ 11.81 / 300	4829 0577
TF-600	1600 ... 6000	32 ... 7200	∅ 23.62 / 600	4829 0578
Set of 3 RJ12 female/female connectors for RJ12 lead extension between power meter and TF sensor				4829 0670

(3) TF Rogowski sensors come with a 6-ft cable lead with RJ12 male connector

(4) Refer to pages 354-355 for more information on TF current sensors

RJ12 sensor lead cables	Cable length (ft / m)										164/50 reel + 100 connectors
	0.32/0.1	0.64/0.2	0.96/0.3	1.64/0.5	3.3/1	6.5/2	9.84/3	16.4/5	22.9/7	32.8/10	
Number of cables	Reference	Reference	Reference	Reference	Reference	Reference	Reference	Reference	Reference	Reference	Reference
1	-	-	-	-	-	-	-	4829 0602	-	4829 0603	4829 0601
3	4829 0580	4829 0581	4829 0582	4829 0595	4829 0583	4829 0584	4829 0606	4829 0607	4829 0608	4829 0609	-
4	-	-	-	4829 0596	4829 0588	4829 0589	-	-	-	-	-
6	4829 0590	4829 0591	4829 0592	4829 0597	4829 0593	4829 0594	-	-	-	-	-

Commissioning

Commissioning		Reference
1/2 day remote commissioning	Remote commissioning including installation verification, programming and communication testing	9230100027
1/2 day on-site commissioning	On-site commissioning including installation verification, programming and communication testing	9230100004

Expert Services

Our service engineers are an essential part of our team, and they are dedicated to ensuring your power monitoring system provides accurate and reliable measurements to your EPMS software or SCADA system.

Our services include:

- > Site audits to verify the proper wiring of your system
- > Personnel training on how to configure, operate and maintain power monitoring equipment and associated software
- > Remote and on-site commissioning to ensure that your system is up and running quickly, with peace of mind.

For further information, please contact your nearest SOCOMEC branch.



DIRIS Digiware IO

Digital and analog input/output module

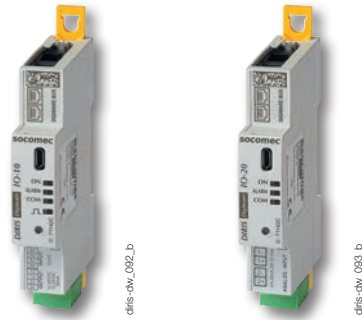

DIRIS Digiware IO-10
4 digital inputs/2 digital outputs

DIRIS Digiware IO-20
2 analog inputs



Configuration with Easy Config System

Function

DIRIS Digiware IO modules give more versatility to the DIRIS Digiware system.

- DIRIS Digiware IO-10 modules have 4 digital inputs and 2 digital outputs. The digital inputs can be used to monitor the status of third-party devices such as the physical position of a protective device (ON/OFF, trip), or to collect and count pulses from multi-utility meters. The digital outputs allow the remote control of protective devices by sending a binary output signal. Alarms from other DIRIS Digiware modules (U, I, S etc.) can be assigned to the IO-10's digital outputs to send signals upon specific conditions (high measurement for example) for additional actions and visibility.
- DIRIS Digiware IO-20 modules have 2 analog inputs used to collect analog signals from external sensors (pressure, humidity, temperature...).

Advantages

Plug & Play

The DIRIS Digiware IO modules can be easily added anywhere within the DIRIS Digiware system thanks to a quick RJ45 connection.

Multifunction

The addition of DIRIS Digiware IO-10/IO-20 modules makes DIRIS Digiware the most comprehensive and versatile power monitoring ecosystem in the market, reducing the need to source third-party equipment.

Connected

All the collected information is accessible from the displays, from WEBVIEW or can be communicated to any other centralized management software.

Compact

The modular format allows the quick connection of a large number of IO-10 and IO-20 modules.

The solution for

- > Industry
- > Building
- > Infrastructure
- > Data center



Strong points

- > Plug & Play
- > Multifunction
- > Connected
- > Compact

Compliance with standards

- > UL 61010-1, CSA-C22.22 No. 61010-1, Guide FTRZ/PICQ, File E257746



- > IEC 61557-12



- > ISO 14025



Create your project

- > Find the best DIRIS Digiware configuration:

www.meter-selector.com



Application diagram

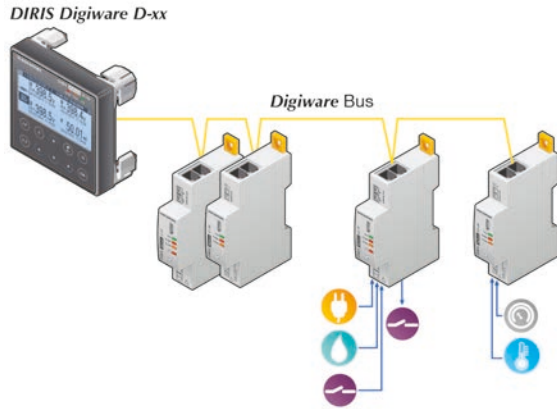

Connections

DIRIS Digiware IO-10

Digital inputs/outputs

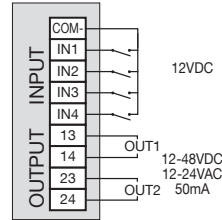

DIRIS Digiware IO-20

Analog inputs

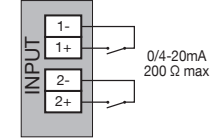

Technical characteristics

Measuring characteristics

Digital inputs/outputs- DIRIS Digiware IO-10

Number of inputs	4
Type/power supply	Insulated input, internal polarisation 12 VDC max., 3 mA
Input function	- Logical status - Breaker position, trip and counter - Pulse counter
Number of outputs	2
Type	Insulated output, 48 VDC max., 50 mA and 24 VAC max.
Output function	- Remote control of status - Operate digital output upon alarm activation on another Digiware module
Input/output connection	Removable screw terminal block, 9 positions (5 dedicated to inputs, 4 dedicated to outputs) AWG 16 to AWG 26 / 0.4 to 1.5 mm ² stranded or solid cable

Analog inputs - DIRIS Digiware IO-20

Number of inputs	2
Type/power supply	0/4-20 mA, 200 Ω max
Accuracy	0.5% full scale
Function	Connection of analog sensors (pressure, humidity, temperature...) with choice of interpolation (linear or quadratic)
Input connection	Removable screw terminal block, 2x2 positions, AWG 14 to AWG 24 / 0.25 to 2.5 mm ² stranded or solid cable

Dimensions (in/mm)

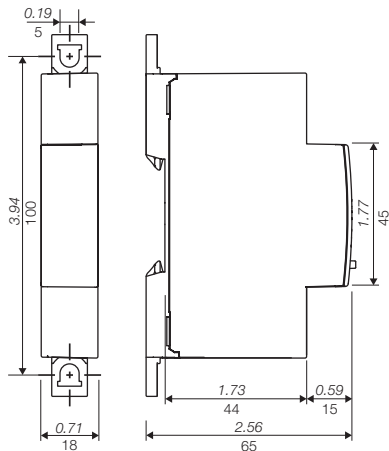

References

DIRIS Digiware IO		Reference
IO-10	4 digital inputs / 2 digital outputs	4829 0140
IO-20	2 analog 0/4-20mA inputs	4829 0145

Accessories		Reference
Digiware Bus terminating resistor (already supplied with DIRIS Digiware C, M & D)		4829 0180
6.5-ft USB Cable for configuration - Type A to Type Micro-B		4829 0050

Digiware bus cables ⁽¹⁾		Reference
RJ45 cables for Digiware Bus	Length 0.20 ft / 0.06 m	4829 0189
	Length 0.32 ft / 0.10 m	4829 0181
	Length 0.66 ft / 0.20 m	4829 0188
	Length 1.64 ft / 0.50 m	4829 0182
	Length 3.28 ft / 1 m	4829 0183
	Length 6.56 ft / 2 m	4829 0184
	Length 9.84 ft / 3 m	4829 0190
	Length 16.4 ft / 5 m	4829 0186
	Length 32.8 ft / 10 m	4829 0187
	164.04 ft / 50 m reel + 100 connectors	4829 0185

(1) To guarantee the proper operation of the DIRIS Digiware system, do not substitute Socomec Digiware bus cables with standard Ethernet RJ45 cables.

Commissioning		Reference
1/2 day remote commissioning	Remote commissioning including installation verification, programming and communication testing	9230100027
1/2 day on-site commissioning	On-site commissioning including installation verification, programming and communication testing	9230100004

DIRIS Digiware Udc

DC voltage measurement module



DIRIS Digiware U-31dc/U-32dc



DIRIS Digiware U500dc/U1000dc/U1500dc adaptor



Configuration with Easy Config System

Function

The **DIRIS Digiware U-3xdc** module measures DC voltage for the entire system. It measures up to 180 VDC with a direct connection and is therefore compatible with typical nominal voltages (24 VDC, 48 VDC, etc.). The voltage adaptors make the system compatible with all voltage levels up to 1650 VDC to respond to the needs of all applications. The RJ45 Digiware Bus transmits voltage measurements along with power supply and communication to all connected products.

Advantages

Single voltage measurement

- Single voltage measurement point for the entire system.
- Single point of protection for the voltage measurement.
- No hazardous voltage on panel doors.

Flexible

- The voltage adaptors make the measurement system compatible with all DC electrical networks.

Plug & Play

- Easy to configure from DIRIS Digiware D interfaces or from the Easy Config configuration software.

The solution for

- > Telecommunication
- > Renewable power
- > Transportation
- > Data center



Strong points

- > Centralization of voltage measurement
- > Flexible
- > Plug & Play

Conformity to standards

- > UL 61010-1, CSA-C22.22 No. 61010-1, Guide FTRZ/PICQ, File E257746



- > IEC 61557-12





- > ISO 14025



Create your project

- > Find the best DIRIS Digiware configuration:

www.meter-selector.com



Application	DC voltage measurement	
		
<i>DIRIS Digiware Udc</i>	<i>U-31dc</i>	<i>U-32dc</i>
Voltage measurement range		
Nominal range	24 ... 48 VDC	60 ... 150 VDC
Min-Max range	19.2 ... 60 VDC	48 ... 180 VDC
Multi-measurement		
DC voltage (VDC)	•	•
Power Quality		
V ripple (voltage ripple)		•
V_{rms}		•
Alarms		
Measurement Thresholds		•
History		
Average values		•
Reference	4829 0150	4829 0151

Application	DC voltage adaptors		
			
<i>DIRIS Digiware Udc</i>	<i>U500dc</i>	<i>U1000dc</i>	<i>U1500dc</i>
Max. voltage range	200 - 600 VDC	400 - 1200 VDC	1200 - 1650 VDC
Udc module association	U-32dc	U-32dc	U-32dc
Reference	4829 0153	4829 0154	4829 0155

(1) U500dc, U1000dc and U1500dc modules can only be associated to the DIRIS Digiware U-32dc module.

Connections

DIRIS Digiware DC wiring with optional Udc voltage adaptors

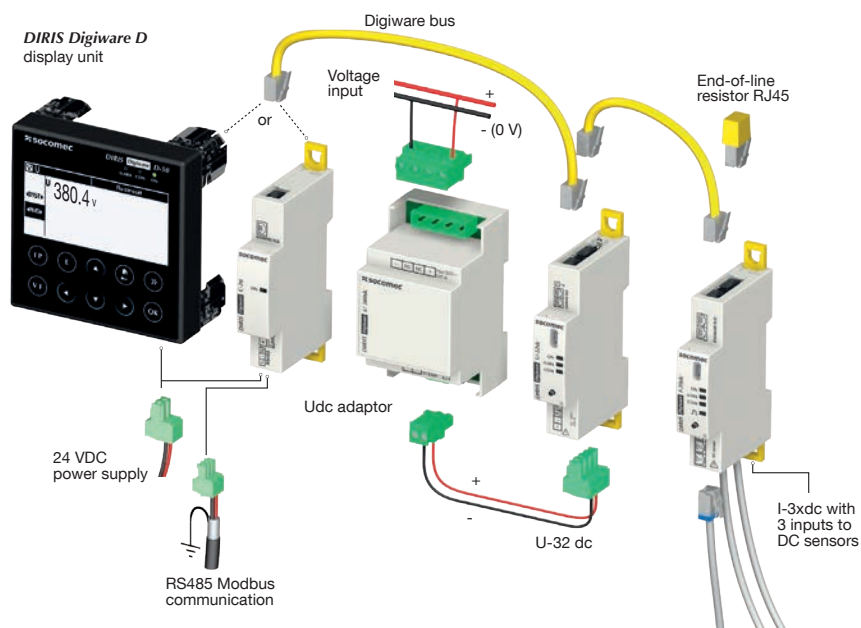

Dimensions (in/mm)

DIRIS Digiware U-3xdc

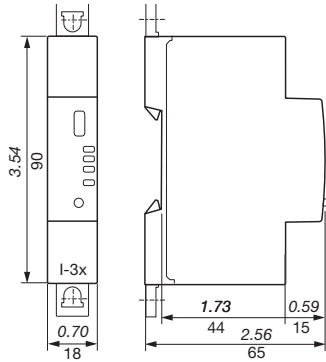

diris-0w_108_a_1_us_cat

DIRIS Digiware adaptors
U500dc/U1000dc/U1500dc

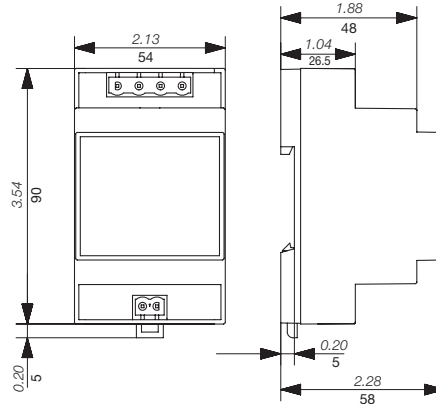

diris-0w_115_a_1_us_cat

Technical characteristics

Measurement characteristics

Voltage range (min-max)	Without adaptors: U-31dc : 19.2 - 60 VDC U-32dc : 48 - 180 VDC
	With adaptor: U-32dc + adaptor U500dc : 200 - 600 VDC U-32dc + adaptor U1000dc : 400 - 1200 VDC U-32dc + adaptor U1500dc : 1200 - 1650 VDC
Voltage measurement accuracy without adaptor	Class 0.5
Voltage measurement accuracy with adaptor	Class 1
Connection without adaptor	Removable screw terminal block, 2 positions, AWG 14 ... AWG 24 / 0.25 ... 2.5 mm ² stranded or solid cable
Connection with adaptor	Adaptor input: Removable screw terminal block, 2 positions, AWG 14 ... AWG 24 / 0.25 ... 2.5 mm ² stranded or solid cable Adaptor output: Removable screw terminal block, 2 positions, AWG 14 ... AWG 24 / 0.25 ... 2.5 mm ² stranded or solid cable
Power consumption	0.6 VA

Mechanical characteristics

Mounting	DIN-rail or back plate
Protection degree	IP20, front face
Weight	2.26 oz / 64 g

Environmental characteristics

Operating temperature	+14 °F ... +158 °F / -10 ... +70 °C
Storage temperature	-13 °F ... +158 °F / -25 ... +70 °C
Operating humidity	0% to 97% RH / +131 °F / +55 °C, non condensing
Operating altitude	≤ 6560 ft / 2000 m

Communication characteristics

USB	
Connection type	USB Type Micro-B
Protocol	Modbus RTU over USB
Function	Firmware upgrade and configuration
Digiware bus	
Connection type	Socomec RJ45 cable
Function	Proprietary bus connecting Digiware units

References

DIRIS Digiware Udc		Reference
U-31dc	Voltage measurement 19.2 ... 60 VDC	4829 0150
U-32dc	Voltage measurement 48 ... 180 VDC	4829 0151
U500dc	Voltage adaptor 200 ... 600 VDC	4829 0153
U1000dc	Voltage adaptor 400 ... 1200 VDC	4829 0154
U1500dc	Voltage adaptor 1200 ... 1650 VDC	4829 0155
Accessories		Reference
Digiware Bus terminating resistor (already supplied with DIRIS Digiware C, M & D)		4829 0180
6.5-ft USB Cable for configuration - Type A to Type Micro-B		4829 0050

Digiware bus cables ⁽¹⁾		Reference
RJ45 cables for Digiware Bus	Length 0.20 ft / 0.06 m	4829 0189
	Length 0.32 ft / 0.10 m	4829 0181
	Length 0.66 ft / 0.20 m	4829 0188
	Length 1.64 ft / 0.50 m	4829 0182
	Length 3.28 ft / 1 m	4829 0183
	Length 6.56 ft / 2 m	4829 0184
	Length 9.84 ft / 3 m	4829 0190
	Length 16.4 ft / 5 m	4829 0186
	Length 32.8 ft / 10 m	4829 0187
	164.04 ft / 50 m reel + 100 connectors	4829 0185

(1) To guarantee the proper operation of the DIRIS Digiware system, do not substitute Socomec Digiware bus cables with standard Ethernet RJ45 cables.

Commissioning		Reference
1/2 day remote commissioning	Remote commissioning including installation verification, programming and communication testing	92301 00027
1/2 day on-site commissioning	On-site commissioning including installation verification, programming and communication testing	92301 00004

Expert Services

Our service engineers are an essential part of our team, and they are dedicated to ensuring your power monitoring system provides accurate and reliable measurements to your EPMS software or SCADA system.

Our services include:

- > Site audits to verify the proper wiring of your system
- > Personnel training on how to configure, operate and maintain power monitoring equipment and associated software
- > Remote and on-site commissioning to ensure that your system is up and running quickly, with peace of mind.

For further information, please contact your nearest SOCOMEC branch.



DIRIS Digiware *Idc*

Direct current measurement module



DIRIS Digiware I-30dc/I-35dc



Function

DIRIS Digiware *Idc* modules measure consumption and monitor the DC electrical installation. Several of these modules can be used within the same system, allowing the measurement of a large number of DC circuits. They are powered with DIRIS Digiware Udc voltage measurement modules.

Direct current is measured using external sensors connected by RJ12-Molex cables, available in multiple lengths. These cables are color coded (brown, orange, white) to easily identify circuits. The associated DIRIS Digiware D screen and the embedded webserver Webview can display electrical measurements from both DIRIS Digiware AC and DC systems simultaneously.

Advantages

Multi-circuit

- Measurement of up to 3 DC circuits per *Idc* module.
- Multiple *Idc* modules can be connected together which allows the measurement of a large number of DC loads simultaneously.

Flexible

- Adapted to suit metering and quality analysis of the direct current.
- A complete range of solid core and split core DC current sensors from 16 to 6000 A.

Plug & Play

- Quick RJ45 connection between modules and RJ12-Molex to current sensors.
- Easy to configure from DIRIS Digiware D interfaces or from the Easy Config System.

Compact

3 DC meters combined in a single module, just 18mm (0.71in) wide, to address space constraints inside electrical panels.

The solution for

- > Data center
- > Telecommunication
- > Renewable power
- > Transportation



Strong points

- > Multi-circuit
- > Plug & Play
- > Flexible
- > Compact

Conformity to standards



- > UL 61010-1, CSA-C22.22 No. 61010-1, Guide FTRZ/PICQ, File E257746



- > ISC 61557-12



- > ISO 14025

Application	Direct current (DC) measurement modules	
		
DIRIS Digiware Idc	I-30dc	I-35dc
General		
Number of RJ12 DC sensor inputs	3	3
Metering		
± kWh	•	•
P (± kW)	•	•
Load curves / demand profile		•
Peak demand		•
Multi-measurement		
DC current (I DC)	•	•
Power Quality		
I ripple (current ripple)		•
I rms		•
Alarms		
Measurement thresholds		•
History		
Average values		•
Reference	4829 0156	4829 0157

Dimensions (in/mm)

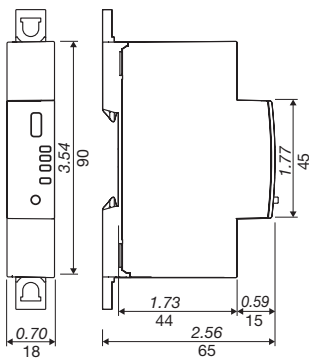

diris-dw_108_a_1_us_callsaps

Current sensors

DC current is measured by external sensors connected to the DIRIS Digiware I-3xdc modules via RJ12-Molex cables. Connection of the current sensors is quick and error free. A wide range of current sensors is available from Socomec to suit all installations and applications including split-core current sensors for retrofit applications.

- Open-loop Hall effect sensors
- Solid core or split core.
- Power supply voltage: ± 15 V.
- Power supply current: ± 25 mA depending on sensor.
- Output voltage: ± 4 V.
- 4-point male Molex terminal strip.
- Measuring range: 16 to 6000 A.
- Category III overvoltage.

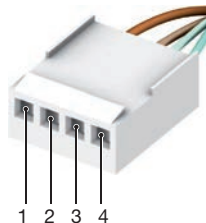

- PIN 1: + 15 V (+ Vc)
- PIN 2: - 15 V (- Vc)
- PIN 3: sensor input (M)
- PIN 4: 0 V sensor (0)

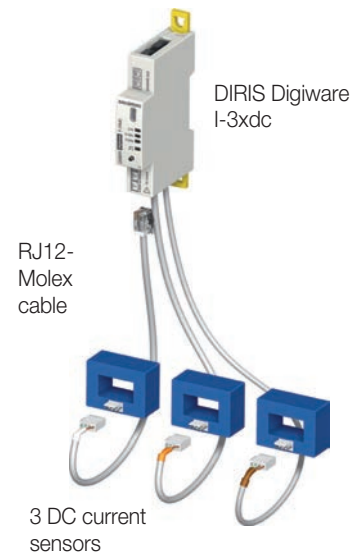

Voltage and current sensors connection examples

Measurement of 3 DC loads

DIRIS Digiware U-31dc
Voltage (VDC): 19 - 60 V

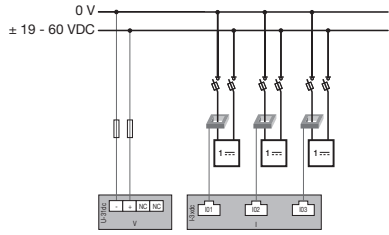

diris-dw_109_a_1_x_cat.eps

DIRIS Digiware U-32dc
Voltage (VDC): 48 - 180 V

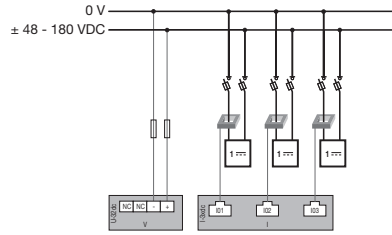

diris-dw_110_a_1_x_cat.eps

DIRIS Digiware U-32dc + adaptor U500dc
Voltage (VDC): 200 - 600 V

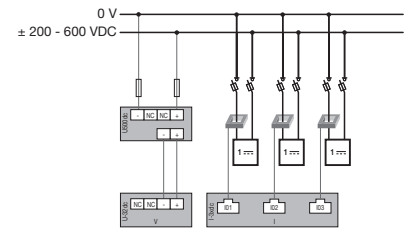

diris-dw_111_a_1_x_cat.eps

DIRIS Digiware U-32dc + adaptor U1000dc
Voltage (VDC): 400 - 1200 V

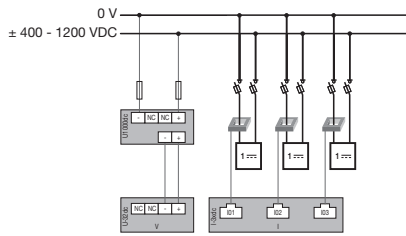

diris-dw_112_a_1_x_cat.eps

DIRIS Digiware U-32dc + adaptor U1500dc
VDC voltage: 1200 - 1500 V +10%

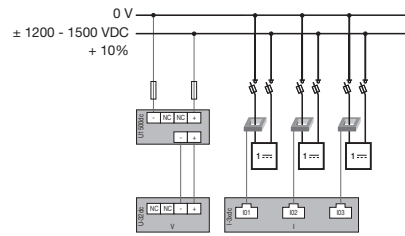

diris-dw_113_a_1_x_cat.eps

1. Fuse: 2A gPV



DC current sensor



DC load

Technical characteristics

Measurement characteristics

Number of current inputs	3
Associated current sensors	Open-loop Hall effect
Current measurement accuracy	Class 0.5
Precision measurement of power and energy	With U-31dc/U-32dc only: class 1 With U-32dc + adaptor: class 2
Connection	Specific Socomec cable with RJ12-Molex connectors
Power consumption	2 VA

Mechanical characteristics

Mounting	DIN-rail or back plate
Protection degree	IP20, front face
Weight	2.43 oz / 69 g

Environmental characteristics

Operating temperature	+14 °F ... +158 °F / -10 ... +70 °C
Storage temperature	-4 °F ... +158 °F / -20 ... +70 °C
Operating humidity	0% to 97% RH / 131 °F / 55 °C, non condensing
Operating altitude	≤ 6560 ft / 2000 m

Communication characteristics

USB	
Connection type	USB Type Micro-B
Protocol	Modbus RTU over USB
Function	Firmware upgrade and configuration
Digiware bus	
Connection type	Socomec RJ45 cable
Function	Proprietary bus connecting Digiware units

References

DIRIS Digiware Idc		Part number
I-30dc	Metering - 3 current inputs	4829 0110
I-35dc	Analysis - 3 current inputs	4829 0111
Accessories		Reference
Digiware Bus terminating resistor (already supplied with DIRIS Digiware C, M & D)		4829 0180
6.5-ft USB Cable for configuration - Type A to Type Micro-B		4829 0050

Digiware bus cables ⁽¹⁾		Reference
RJ45 cables for Digiware Bus	Length 0.20 ft / 0.06 m	4829 0189
	Length 0.32 ft / 0.10 m	4829 0181
	Length 0.66 ft / 0.20 m	4829 0188
	Length 1.64 ft / 0.50 m	4829 0182
	Length 3.28 ft / 1 m	4829 0183
	Length 6.56 ft / 2 m	4829 0184
	Length 9.84 ft / 3 m	4829 0190
	Length 16.4 ft / 5 m	4829 0186
	Length 32.8 ft / 10 m	4829 0187
164.04 ft / 50 m reel + 100 connectors		4829 0185

(1) To guarantee the proper operation of the DIRIS Digiware system, do not substitute Socomec Digiware bus cables with standard Ethernet RJ45 cables.

References - DC current sensors

DC solid-core current sensors ⁽²⁾			
Model	Nominal current range (A)	Window size (in/mm)	Reference
Frame size 1	50	0.80 x 0.41 / 20.4 x 10.4	4829 0700
	100	0.80 x 0.41 / 20.4 x 10.4	4829 0701
	200	0.80 x 0.41 / 20.4 x 10.4	4829 0702
	300	0.80 x 0.41 / 20.4 x 10.4	4829 0703
	400	0.80 x 0.41 / 20.4 x 10.4	4829 0704
	500	0.80 x 0.41 / 20.4 x 10.4	4829 0705
Frame size 2	600	0.80 x 0.41 / 20.4 x 10.4	4829 0706
	850	2.52 x 0.83 / 64 x 21	4829 0707
	1000	2.52 x 0.83 / 64 x 21	4829 0708
	1500	2.52 x 0.83 / 64 x 21	4829 0709
	2000	2.52 x 0.83 / 64 x 21	4829 0710
	2500	2.52 x 0.83 / 64 x 21	4829 0711
	5000	2.52 x 0.83 / 64 x 21	4829 0712

(2) Refer to pages 356-359 for more information on DC sensors

DC split-core current sensors ⁽²⁾			
Model	Nominal current range (A)	Window size (in/mm)	Reference
Frame size 1	50	∅ 0.83 / 21	4829 0750
	100	∅ 0.83 / 21	4829 0751
	200	∅ 0.83 / 21	4829 0752
	300	∅ 0.83 / 21	4829 0753
	400	∅ 0.83 / 21	4829 0754
	500	∅ 0.83 / 21	4829 0755
Frame size 2	800	4.09 x 1.57 / 104 x 40	4829 0756
	1000	4.09 x 1.57 / 104 x 40	4829 0757
	1500	4.09 x 1.57 / 104 x 40	4829 0758
	2000	4.09 x 1.57 / 104 x 40	4829 0759

(2) Refer to pages 356-359 for more information on DC sensors

RJ12 sensor lead cables	Cable length (ft / m)				
	0.96/0.3	1.64/0.5	3.3/1	6.5/2	16.4/5
Number of cables	Reference	Reference	Reference	Reference	Reference
1	-	-	-	-	4829 0786
3	4829 0782	4829 0783	4829 0784	4829 0785	-

Commissioning		Reference
1/2 day remote commissioning	Remote commissioning including installation verification, programming and communication testing	9230100027
1/2 day on-site commissioning	On-site commissioning including installation verification, programming and communication testing	9230100004

Expert Services

Our service engineers are an essential part of our team, and they are dedicated to ensuring your power monitoring system provides accurate and reliable measurements to your EPMS software or SCADA system.

Our services include:

- > Site audits to verify the proper wiring of your system
- > Personnel training on how to configure, operate and maintain power monitoring equipment and associated software
- > Remote and on-site commissioning to ensure that your system is up and running quickly, with peace of mind.

For further information, please contact your nearest SOCOMEC branch.



DIRIS A-100 / A-200

Power quality meter - panel mounted

Works with RJ12 or 333 mV current sensors



Function

The **DIRIS A-100 / A-200** are panel-mounted power quality meters that can communicate either via MODBUS RTU over RS485, MODBUS TCP and BACnet IP over Ethernet. The 4 independent current inputs allow to manage several types and numbers of circuits. The DIRIS A-100 / A-200 are compatible with all types of current sensor technologies: solid-core, split-core and Rogowski coil sensors to match any project requirements and installation constraints.

Advantages

Universal

The DIRIS A-100/A-200 is an all-in-one power quality meter providing a cost-effective answer to all application requirements:

- Native RS485 and dual Ethernet communication and digital inputs/outputs, eliminating the need for additional optional modules.
- Universal power supply 115 - 600 VAC.
- Wide range voltage service monitoring 90 - 690 VAC direct without using potential transformers.
- Compatible with any third party 333mV Current Transformers.

Plug & play

- Unique RJ12 technology provides a quick and reliable connection of current sensors to the power meter.
- Using mV output CTs means that no shorting blocks are needed.
- Fast and simple setup thanks to the screen's Configuration Wizard.
- Easy Config System is a free configuration software that allows you to create and save configuration templates which can later be uploaded to other A-100/A-200.
- Smart monitoring of protective devices with VirtualMonitor technology - without the need for auxiliary contacts or extra wiring.

Fully customizable

- Upload your own brand logo to customize the screen and embedded webserver.
- Creation of rolling favorite screens to display the measurement datasets that matter most to you.

Advanced features

- Waveform capture automatically triggered by power quality events to rapidly identify disturbances.
- Time of Use calendar configuration (up to 4 seasons and 4 tariffs) to align consumptions with any local utility contract.
- Ground leakage current monitoring, with alarm thresholds for preventative maintenance and quick remedial action.

Better than revenue grade

PreciSense technology provides industry leading accuracy which exceed revenue grade standards, for reliable and repeatable measurements under all conditions:

- Class 0.1 for the meter alone according to ANSI C12.20 and IEC 61557-12 standard.
- Class 0.5 from 2% to 120% of the CT rating for the global measurement chain (with TE/TR/TF/ACTL-1250 current sensors).

The solution for

- > Data center
- > Industry
- > Building

Strong points

- > Universal
- > Plug & play
- > Fully customizable
- > Advanced features
- > Better than revenue grade

Conformity to standards

- > UL 61010-1
CSA-C22.22
No. 61010-1
Guide FTRZ/PICQ
File E257746



- > ANSI C12.20



- > PBI Meter per CA Energy Commission



- > IEC 61557-12

- > IEC 62053-21 -24

Integrated technologies







For more information see our website www.socomec.us

DIRIS A-100 / A-200

Power quality meter - panel mounted

Works with RJ12 or 333 mV current sensors

				
DIRIS A	A-100	A-100	A-200	A-200
Current sensor technology	RJ12	333 mV	RJ12	333 mV
General				
Format	Door Mount	Door Mount	Door Mount	Door Mount
Number of current sensor inputs	4	4	4	4
Available enclosed			•	
Electrical				
Power supply	115 - 600 VAC	115 - 600 VAC	115 - 600 VAC	115 - 600 VAC
Voltage measurement	50 - 600 VAC L-N 90 - 690 VAC L-L	50 - 600 VAC L-N 90 - 690 VAC L-L	50 - 600 VAC L-N 90 - 690 VAC L-L	50 - 600 VAC L-N 90 - 690 VAC L-L
Communication				
RS485 Modbus RTU	•	•	•	•
Ethernet (Modbus TCP/BACnet IP)			•	•
WEBVIEW web interface			•	•
Digital Input / Output	3 / 1	3 / 1	3 / 1	3 / 1
Analog Input / Output	- / -	- / -	- / -	- / -
Energy metering				
±kWh, ±kvarh, kVAh	•	•	•	•
ΣP (kW), ΣQ (kvar), ΣS (kVA), PF	•	•	•	•
P (kW), Q (kvar), S (kVA), PF per phase	•	•	•	•
Predictive Power	•	•	•	•
Load curves / demand profiles	•	•	•	•
Peak Demand	•	•	•	•
Multi-tariff	4 (with Time of Use)	4 (with Time of Use)	4 (with Time of Use)	4 (with Time of Use)
Multi - measurement				
U12, U23, U31, V1, V2, V3, f	•	•	•	•
U system, V system	•	•	•	•
I1, I2, I3, In, I system	•	•	•	•
Unbalance U, V, I	•	•	•	•
Phi, cos Phi, tan Phi	•	•	•	•
Power quality				
THD U, V, I	•	•	•	•
Individual Harmonics U, V, I (up to 63rd)			•	•
Ground Leakage Monitoring			•	
Crest Factor I1, I2, I3	•	•	•	•
K-Factor	•	•	•	•
PQ Events (sags, swells, interruptions, overcurrents)	•	•	•	•
Waveform capture			•	•
Alarms				
Measurement thresholds	•	•	•	•
System alarms	•	•	•	•
Protective device	•	•	•	•
Logical (digital input status)	•	•	•	•
History				
Average Values	•	•	•	•
Reference	4825 0600	4825 0601	4825 0604	4825 0605

DIRIS A-100 / A-200

Power quality meter - panel mounted

Works with RJ12 or 333 mV current sensors

Functions

Monitoring

- Real-time visualization of all electrical parameters, available under several formats (bar graphs, tables)
- Phasor diagram to identify potential CT wiring errors



Consumption curves

- Recording of active (kWh), reactive (kvarh) and apparent (kVAh) energies
- Graphical view of monthly, weekly, daily or hourly energy consumptions to detect drifts



Time of Use

- Custom calendar management
- Energy consumption displayed according to the utility's daily rates, weekdays, seasons and holiday schedules



Measurement history

- History of all electrical parameters (V, I, P, Q, S, THD etc.)
- Time period selection (year, month, day etc.)
- Easy correlation, by displaying multiple parameters on the same graph

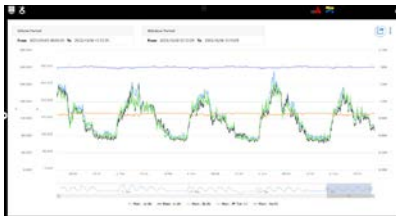

Alarms & Events

- View active alarms and power quality events
- Access to details (duration, amplitude etc.)
- Log of finished alarms & events

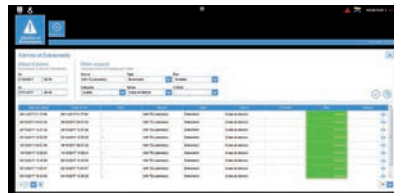

Waveform

- Automatic waveform captures following power quality events
- Waveform picture and samples can be downloaded from the webserver



Terminals

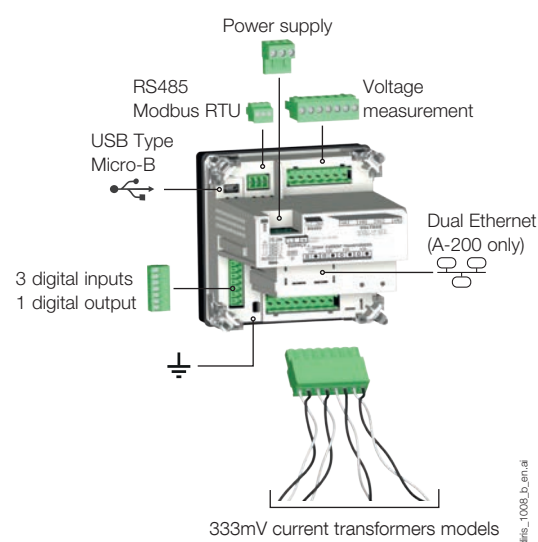
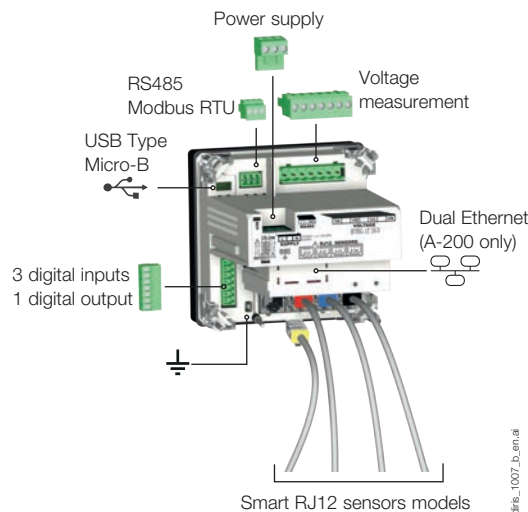

Terminals (continued)

3 Digital inputs Self-supplied by PMD

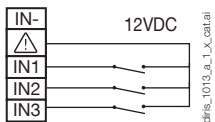

External power supply

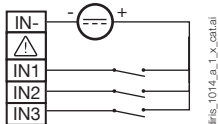

1 digital output

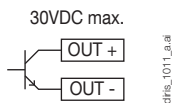

Voltage and power supply connections

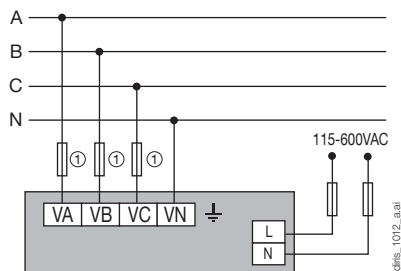

1. 1 A gG / 1 A class CC Listed fuses for UL application.

Ground



Power supply



RS485

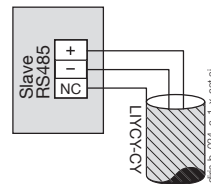

Dual Ethernet

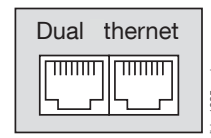

Current measurement

RJ12 version

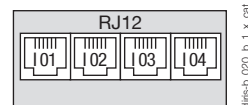

333mV version

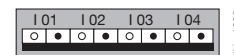

Dimensions (in/mm)

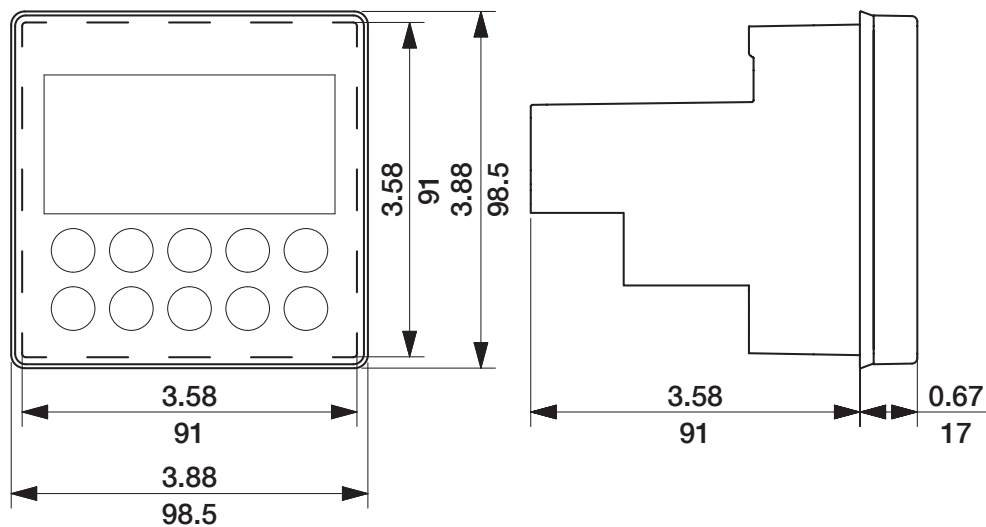

DIRIS A-100 / A-200

Power quality meter - panel mounted

Works with RJ12 or 333 mV current sensors

Current sensors

The DIRIS A-100/A-200 supports various types of current sensors including smart RJ12 solid-core (TE), split-core (TR/iTR), and Rogowski coil (TF) sensors (A-100/A-200 RJ12 models), as well as any 333 mV current sensors (A-100/A-200 333 mV models). Additionally, the DIRIS A-200 RJ12 model (reference 4825 0604) can accommodate zero-sequence $\Delta IC/\Delta IP-R$ CTs for ground leakage monitoring. This versatile range of sensors makes the DIRIS A-100/A-200 suitable for both new and existing installations.

TE solid current sensors



TR/iTR split-core current sensors



TF Rogowski current sensors



333mV current sensors



$\Delta IC/\Delta IP-R$ zero sequence CTs



RJ12 smart current sensors

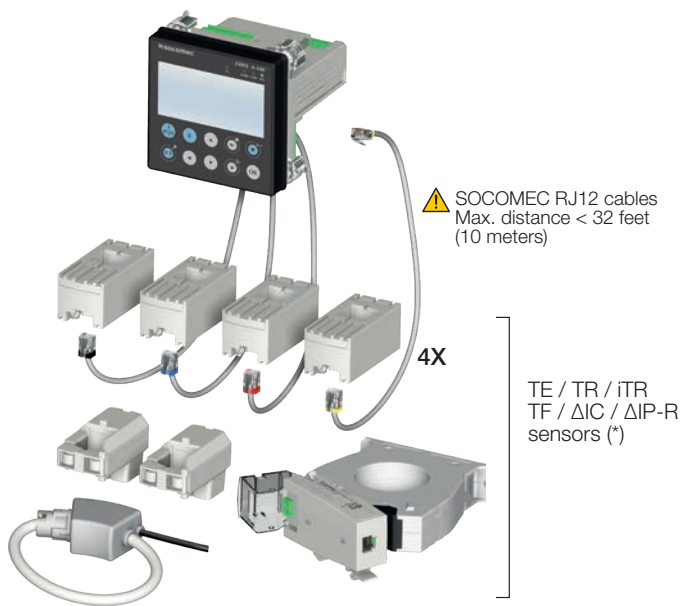

Current transformers with 333 mV outputs

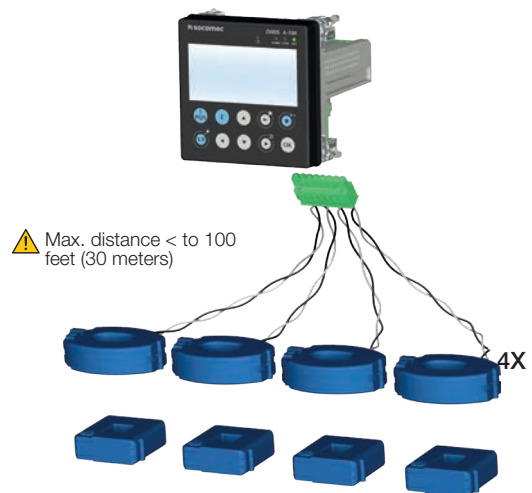

(*) Notes regarding the use of zero sequence CTs:

1. $\Delta IC / \Delta IP-R$ zero sequence CTs for ground leakage monitoring are only compatible with the DIRIS A-200 RJ12 model (part no 48250604).
2. Only one $\Delta IC / \Delta IP-R$ may be connected on the DIRIS A-200 power meter.
3. DIRIS T-10 RJ12 adaptor (part no 48290620) must be used and ordered separately to connect $\Delta IC / \Delta IP-R$ to the DIRIS A-200 power meter.

Voltage and current sensor connection examples - RJ12 models

Three-Phase, Four-Wire Wye
3P+N - 4CT

(1 three-phase load + measured neutral)

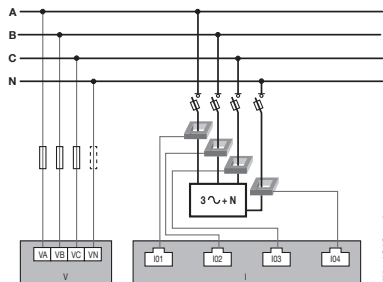

Three-Phase, Four-Wire Wye
3P+N - 3CT & 3P - 1CT

(1 unbalanced three-phase load + calculated Neutral + 1 three-phase balanced load)

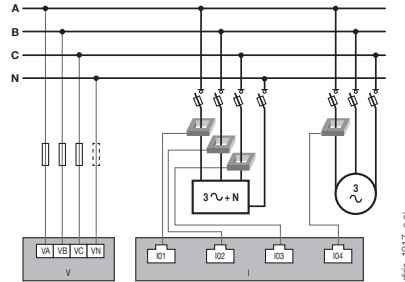

Single-Phase, Two-Wire, Line-to-Neutral
1P+N - 1CT (x4)

(4 single-phase loads)

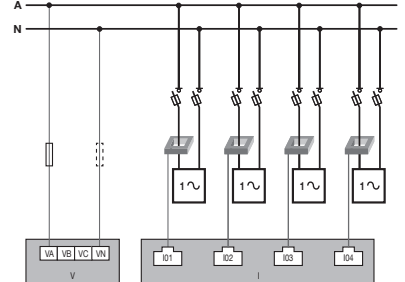

Three-Phase Four-Wire Delta (High Leg)
3P+N - 3CT

(1 three-phase load)

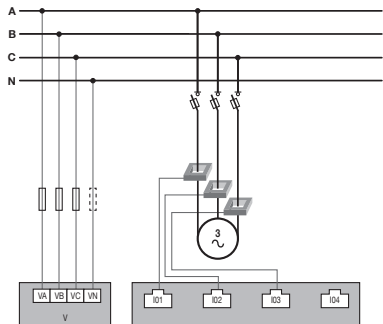

Three-Phase, Four-Wire Wye
3P+N - 3CT

(1 three-phase load with RCM* (Δ))

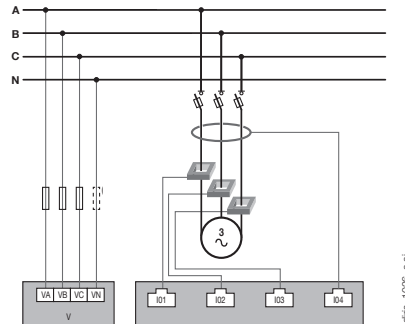

* only for DIRIS A-200 RJ12 model (ref. 48250604).

Three-Phase, Three-Wire Delta
3P - 1CT (x4)

(4 three-phase balanced loads)

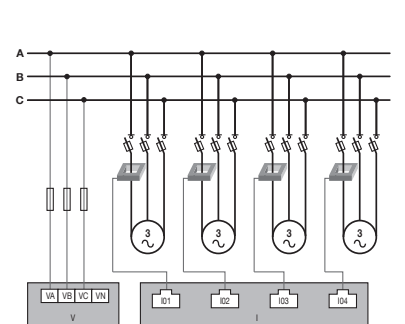

Voltage and current sensor connection examples - 333 mV models

Three-Phase, Four-Wire Wye
3P+N - 4CT

(1 three-phase load + measured neutral)

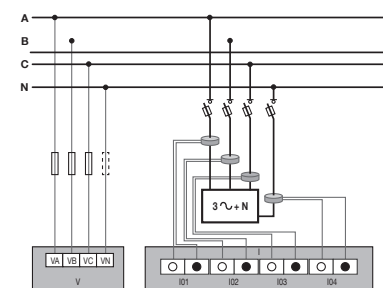

Three-Phase, Four-Wire Wye
3P+N - 3CT & 1P+N - 1CT

(1 three-phase load + calculated Neutral + 1 single-phase load)

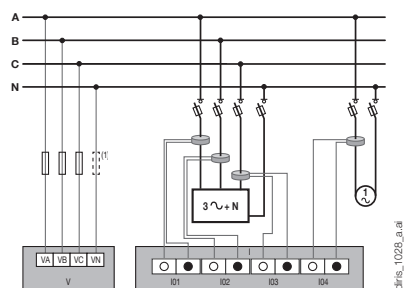

Three-Phase Four-Wire Delta (High Leg)
3P+N - 3CT

(1 three-phase load)

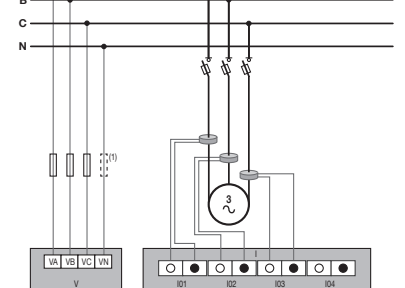

 Fuse: 1 A gG / 1 A class CC
 Listed fuses for UL application

 TE / TR / iTR / TF
 sensors

 333 mV current
 transformers

 Balanced load

 Unbalanced load

 Zero sequence CT

DIRIS A-100 / A-200

Power quality meter - panel mounted

Works with RJ12 or 333 mV current sensors

Technical characteristics

Electrical characteristics		
Power supply		
Voltage	115-600 VAC L/N L/L, CAT III	
Frequency	50-60 Hz	
Power consumption	A-100: 5VA, A-200: 7VA	
Connection (Use copper conductors only)	Removable spring-cage terminal block, 2 positions, 28-12 AWG (1-2.5 mm ²) solid or stranded cable with ferrule	
Measurement characteristics		
Standards		
Active energy accuracy	ANSI C12.20	Class 0.2 DIRIS A-100/A-200 alone
	IEC 61557-12	Class 0.2 DIRIS A-100/A-200 alone Global accuracy class from 2% to 120% of In (meter + sensors): - Class 0.5 system accuracy with TE, iTR, TF, ACTL-1250 current sensors - Class 1 system accuracy with TR or ACTL-0750 current sensors
Reactive energy accuracy	IEC 62053-24	Class 1 DIRIS A-100/A-200 alone Class 2 system accuracy with TE, TR/iTR or TF current sensors
Voltage measurement		
Voltage range	50-600 VAC L-N UL CAT III 90-690 VAC L-L UL CAT III 50-1039 VAC L-L IEC CAT III	
Frequency range	45 to 65 Hz	
Electrical service type	Single-Phase, Two-Wire, Line-to-Neutral, Single-Phase, Two-Wire, Line-to-Line, Single-Phase, Three-Wire (Split-Phase), Three-Phase, Three-Wire Delta, Three-Phase, Four-Wire Wye, Three-Phase Four-Wire Delta (High Leg)	
Measurement by voltage transformer	Primary: 400 000 VAC Secondary: 60, 100, 110, 173, 190 VAC	
Input consumption	≤ 0.1 VA	
Connection (Use copper conductors only)	Removable spring-cage terminal block, 4 positions, 28-12 AWG (1-2.5 mm ²) solid or stranded cable with ferrule	
Current measurement		
Number of current inputs	4	
Associated current sensors	- Smart RJ12 sensors: solid-core TE, split-core TR and iTR, flexible TF current sensors - 333 mV current sensors: split-core ACTL 0750-xxx, ACTL-1250-xxx - ΔIC circular solid-core and ΔIP-R circular split-core zero-sequence CT with T-10 RJ12 adaptor	

Input/output characteristics	
Inputs	
Number	3
Type / Power supply	Optocoupler with internal (12 VDC ± 10%) or external (10-30 VDC) polarisation 27 mA max.
Input function	Logical state, pulse meter, breaker status or sync. pulse signal (input 1)
Connection	Removable screw terminal block, 5 positions, stranded or solid 18-16 AWG (0.5-1.5 mm ²)
Outputs	
Number	1
Type	Optocoupler 30 VDC max 20 mA max - SELV
Output function	Configurable alarm signal (current, power, etc.) when threshold is exceeded or remote control through communication command
Connection	Removable screw terminal block, 4 positions, stranded or solid 18-16 AWG (0.5-1.5 mm ²)

Communication characteristics

RS485	
Link	RS485
Connection type	Half-Duplex, 2 wires
Protocol	Modbus RTU
Baud rate	9600 to 115200 bauds

Ethernet (A-200 only)	
Link	Ethernet
Connection type	RJ45 10/100 Mbs
Protocol	Modbus TCP/IP, BACnet IP

USB	
Link	USB Type Micro-B
Purpose	Configuration via Easy Config System and firmware upgrade via Product Upgrade Tool

Environmental characteristics

Storage temperature	-40 ... +85°C / -40 ... +185°F (ANSI C12.1)
Operating temperature	-25 ... +70°C / -13 ... +158°F (ANSI C12.1)
Humidity	5 to 95% RH non condensing (ANSI C12.1)
Degree of pollution	2

References

DIRIS A power meters

DIRIS A-100	RS485 - Smart RJ12 current sensors	4825 0600
DIRIS A-100	RS485 - 333 mV current sensors	4825 0601
DIRIS A-200	RS485 + Dual Ethernet - Smart RJ12 current sensors	4825 0604
DIRIS A-200	RS485 + Dual Ethernet - 333 mV current sensors	4825 0605

Accessories

	Sold in multiples of	Reference
DIN-rail mounting accessory	1	4825 0690
3-pole RM Class CC fuse holder to protect voltage inputs	4	5705 0003
2-pole RM Class CC fuse holder to protect power supply input	6	5701 0002
1A/5A secondary CT adapter with RJ12 output	1	4829 0599
6.5-ft USB Cable for configuration - Type A to Type Micro-B	1	4829 0050

RJ12 Solid-core current sensors ⁽¹⁾

Model	Nominal current range (A)	Real range covered (A)	Window size (in/mm)	Reference
TE-18	5 ... 20	0.1 ... 24	Ø 0.33 / 8.6	4829 0500
TE-18	25 ... 63	0.5 ... 75	Ø 0.33 / 8.6	4829 0501
TE-25	40 ... 160	0.8 ... 192	0.53 x 0.53 / 13.5 x 13.5	4829 0502
TE-35	63 ... 250	1.26 ... 300	0.82 x 0.82 / 21 x 21	4829 0503
TE-45	160 ... 630	3.2 ... 756	1.22 x 1.22 / 31 x 31	4829 0504
TE-55	400 ... 1000	8 ... 1200	1.61 x 1.61 / 41 x 41	4829 0505
TE-90	600 ... 2000	12 ... 2400	2.52 x 2.52 / 64 x 64	4829 0506

(1) Refer to pages 348-351 for more information on TE current sensors

RJ12 Split-core current sensors ⁽²⁾

Model	Nominal current range (A)	Real range covered (A)	Window size (in/mm)	Reference
TR-10 / iTR-10	25 ... 63	0.5 ... 75.6	Ø 0.39 / 10	4829 0555 / 4829 0655
TR-14 / iTR-14	40 ... 160	0.8 ... 192	Ø 0.55 / 14	4829 0556 / 4829 0656
TR-21 / iTR-21	63 ... 250	1.26 ... 300	Ø 0.83 / 21	4829 0557 / 4829 0657
TR-32 / iTR-32	160 ... 600	3.2 ... 720	Ø 1.26 / 32	4829 0558 / 4829 0658

(2) Refer to pages 352-353 for more information on TR/iTR current sensors

RJ12 Flexible Rogowski current sensors ^{(3) (4)}

Model	Nominal current range (A)	Real range covered (A)	Window size (in/mm)	Reference
TF-40	100 ... 400	2 ... 480	Ø 1.57 / 40	4829 0573
TF-80	150 ... 600	3 ... 720	Ø 3.15 / 80	4829 0574
TF-120	400 ... 2000	8 ... 2400	Ø 4.72 / 120	4829 0575
TF-200	600 ... 4000	12 ... 4800	Ø 7.87 / 200	4829 0576
TF-300	1600 ... 6000	32 ... 7200	Ø 11.81 / 300	4829 0577
TF-600	1600 ... 6000	32 ... 7200	Ø 23.62 / 600	4829 0578
Set of 3 RJ12 female/female connectors for RJ12 lead extension between power meter and TF sensor				4829 0670

(3) TF Rogowski sensors come with a 6-ft cable lead with RJ12 male connector

(4) Refer to pages 354-355 for more information on TF current sensors

RJ12 sensor lead cables	Cable length (ft / m)										164/50 reel + 100 connectors
	0.32/0.1	0.64/0.2	0.96/0.3	1.64/0.5	3.3/1	6.5/2	9.84/3	16.4/5	22.9/7	32.8/10	
Number of cables	Reference	Reference	Reference	Reference	Reference	Reference	Reference	Reference	Reference	Reference	Reference
1	-	-	-	-	-	-	-	4829 0602	-	4829 0603	4829 0601
3	4829 0580	4829 0581	4829 0582	4829 0595	4829 0583	4829 0584	4829 0606	4829 0607	4829 0608	4829 0609	-
4	-	-	-	4829 0596	4829 0588	4829 0589	-	-	-	-	-
6	4829 0590	4829 0591	4829 0592	4829 0597	4829 0593	4829 0594	-	-	-	-	-

DIRIS A-100 / A-200

Power quality meter - panel mounted

Works with RJ12 or 333 mV current sensors

References (continued)

333 mV split-core current sensors						
Model	Primary rating (A)	Real range covered (A)	Accuracy	Window size (in/mm)	Output lead length (ft / m)	Reference
TR-10W	63	3 ... 75.6	0.50%	Ø 0.39 / 10	22 / 7	194S 5010
TR-14W	160	8 ... 192	0.50%	Ø 0.55 / 14	22 / 7	194S 5014
TR-21W	250	12.5 ... 300	0.50%	Ø 0.83 / 21	22 / 7	194S 5021
TR-32W	600	30 ... 720	0.50%	Ø 1.26 / 32	22 / 7	194S 5032
ACTL-0750-20	20	0.2 ... 24	0.75%	0.78 x 0.78 / 20 x 20	8 / 2.4	USACTL0750020
ACTL-0750-20-C06	20	0.2 ... 24	0.50%	0.78 x 0.78 / 20 x 20	8 / 2.4	USACTL0750020C06
ACTL-0750-50	50	0.5 ... 60	0.75%	0.78 x 0.78 / 20 x 20	8 / 2.4	USACTL0750050
ACTL-0750-50-C06	50	0.5 ... 60	0.50%	0.78 x 0.78 / 20 x 20	8 / 2.4	USACTL0750050C06
ACTL-0750-100	100	1 ... 120	0.75%	0.78 x 0.78 / 20 x 20	8 / 2.4	USACTL07500100
ACTL-0750-100-C06	100	1 ... 120	0.50%	0.78 x 0.78 / 20 x 20	8 / 2.4	USACTL07500100C06
ACTL-0750-150	150	1.5 ... 180	0.75%	0.78 x 0.78 / 20 x 20	8 / 2.4	USACTL07500150
ACTL-0750-150-C06	150	1.5 ... 180	0.50%	0.78 x 0.78 / 20 x 20	8 / 2.4	USACTL07500150C06
ACTL-0750-200	200	2 ... 240	0.75%	0.78 x 0.78 / 20 x 20	8 / 2.4	USACTL07500200
ACTL-0750-200-C06	200	2 ... 240	0.50%	0.78 x 0.78 / 20 x 20	8 / 2.4	USACTL07500200C06
ACTL-0750-250	250	2.5 ... 300	0.75%	0.78 x 0.78 / 20 x 20	8 / 2.4	USACTL07500250
ACTL-0750-250-C06	250	2.5 ... 300	0.50%	0.78 x 0.78 / 20 x 20	8 / 2.4	USACTL07500250C06
ACTL-1250-250	250	2.5 ... 300	0.75%	Ø 1.77 x 1.26 / 45 x 32	8 / 2.4	USACTL1250250
ACTL-1250-250-C06	250	2.5 ... 300	0.50%	Ø 1.77 x 1.26 / 45 x 32	8 / 2.4	USACTL1250250C06
ACTL-1250-250-C02	250	2.5 ... 300	0.20%	Ø 1.77 x 1.26 / 45 x 32	8 / 2.4	USACTL1250250C02
ACTL-1250-400	400	4 ... 480	0.75%	Ø 1.77 x 1.26 / 45 x 32	8 / 2.4	USACTL1250400
ACTL-1250-400-C06	400	4 ... 480	0.50%	Ø 1.77 x 1.26 / 45 x 32	8 / 2.4	USACTL1250400C06
ACTL-1250-400-C02	400	4 ... 480	0.20%	Ø 1.77 x 1.26 / 45 x 32	8 / 2.4	USACTL1250400C02
ACTL-1250-600	600	6 ... 720	0.75%	Ø 1.77 x 1.26 / 45 x 32	8 / 2.4	USACTL1250600
ACTL-1250-600-C06	600	6 ... 720	0.50%	Ø 1.77 x 1.26 / 45 x 32	8 / 2.4	USACTL1250600C06
ACTL-1250-600-C02	600	6 ... 720	0.20%	Ø 1.77 x 1.26 / 45 x 32	8 / 2.4	USACTL1250600C02

Commissioning		Reference
1/2 day remote commissioning	Remote commissioning including installation verification, programming and communication testing	9230100027
1/2 day on-site commissioning	On-site commissioning including installation verification, programming and communication testing	9230100004

DIRIS A-100 / A-200

Power quality meter - panel mounted

Works with RJ12 or 333 mV current sensors

Expert Services

Our service engineers are an essential part of our team, and they are dedicated to ensuring your power monitoring system provides accurate and reliable measurements to your EPMS software or SCADA system.

Our services include:

- > Site audits to verify the proper wiring of your system
- > Personnel training on how to configure, operate and maintain power monitoring equipment and associated software
- > Remote and on-site commissioning to ensure that your system is up and running quickly, with peace of mind.

For further information, please contact your nearest SOCOMEC branch.



DIRIS A-40

Multifunction power meter - panel mounted
Works with RJ12 smart current sensors



DIRIS A-40



Configuration
with Easy Config System

Function

The DIRIS A-40 is a panel mounted power monitoring device compatible with TE/TR/ITR/TF smart current sensors, suitable for new or existing electrical installations.

The DIRIS A-40 has 3 native digital inputs and 2 digital outputs for additional versatility and includes RS485 Modbus RTU, Ethernet Modbus TCP and BACnet IP, and Profibus DP communication to report measurements to external management systems.

Advantages

Plug & Play

- Color-coded RJ12 cables for easy phase identification when wiring current sensors to the DIRIS A-40.
- Automatic detection of current sensor type and rating.
- Using low-voltage mV current sensors, no shunting blocks are needed, they can be disconnected safely under load.

Smart sensors

Three current sensor formats (solid-core TE, split-core TR/ITR and Rogowski coil TF) allow integration of the DIRIS A-40 into new and existing electrical installations.

Assisted configuration

A configuration wizard guides the user in a step by step process to configure the DIRIS A-40 directly from the screen. It also detects and corrects configuration errors which cuts the commissioning time in half and always delivers a reliable result.

Better than revenue grade

Compliant with the IEC 61557-12 standard, guaranteeing the quality and accuracy of the Power Meter:

- Class 0.2 for the meter alone.
- Class 0.5 from 2% to 120% of the rated current, for the global measurement chain (with TE/ITR/TF current sensors).

The solution for

- > Industry
- > Building
- > Infrastructure
- > Data center



Strong points

- > Plug & Play
- > Assisted configuration
- > Smart sensors
- > Better than revenue grade

Integrated technologies



PreciSense



AutoCorrect



VirtualMonitor

For more information see our website
www.socomec.us

Conformity to standards

- > UL 61010-1
CSA-C22.22
No.61010-1
Guide FTRZ/PICQ
File E257746



- > ANSI 12.20

- > PBI Meter per
CA Energy
Commission





- > IEC 61557-12



- > ISO 14025

DIRIS A-40

Multifunction power meter - panel mounted
Works with RJ12 smart current sensors

			
DIRIS A-40			
Current sensor technology	RJ12	RJ12	RJ12
General			
Format	Door Mount	Door Mount	Door Mount
Number of current sensor inputs	3	3	3
Available enclosed		•	
Electrical			
Power supply	110 - 277 VAC	110 - 277 VAC	110 - 277 VAC
Voltage measurement	50 - 300 VAC L-N 87 - 520 VAC L-L	50 - 300 VAC L-N 87 - 520 VAC L-L	50 - 300 VAC L-N 87 - 520 VAC L-L
Communication			
RS485 Modbus RTU	•	•	•
Ethernet (Modbus TCP/BACnet IP)		•	
Profibus DPV1			•
WEBVIEW web interface		•	
Digital Input / Output	3 / 2	3 / 2	3 / 2
Analog Input / Output	- / -	- / -	- / -
Energy metering			
±kWh, ±kvarh, kVAh	•	•	•
ΣP (kW), ΣQ (kvar), ΣS (kVA), PF	•	•	•
P (kW), Q (kvar), S (kVA), PF per phase	•	•	•
Predictive Power	•	•	•
Load curves / demand profiles	•	•	•
Peak Demand	•	•	•
Multi-tariff	8	8	8
Multi - measurement			
U12, U23, U31, V1, V2, V3, f	•	•	•
U system, V system	•	•	•
I1, I2, I3, In, I system	•	•	•
Unbalance U, V, I	•	•	•
Phi, cos Phi, tan Phi	•	•	•
Power quality			
THD U, V, I	•	•	•
Individual Harmonics U, V, I (up to 63rd)			•
Crest Factor I1, I2, I3	•	•	•
K-Factor	•	•	•
PQ Events (sags, swells, interruptions, overcurrents)	•	•	•
Alarms			
Measurement thresholds	•	•	•
System alarms	•	•	•
Protective device	•	•	•
Logical (digital input status)	•	•	•
History			
Average Values	•	•	
Reference	4825 0500	4825 0501	4825 0502

DIRIS A-40

Multifunction power meter - panel mounted
Works with RJ12 smart current sensors

WEBVIEW-S - embedded webserver

Real time

- Real-time visualization of electrical values.
- View data as graphs or tables.
- Power quality analysis of the utility supply and of loads.

Historical

- Consumption curves (kWh, kvarh, kVAh)
- Demand profiles (kW, kvar, kVA) with peak demand
- Graphic display with monthly, weekly, daily or hourly breakdown.

Alarms

- List of active alarms.
- Log of finished alarms



soft_027_a_1_fr_cat_1.eps



soft_036_a_1_fr_cat_1.eps



soft_025_a_1_fr_cat_1.eps

Terminals

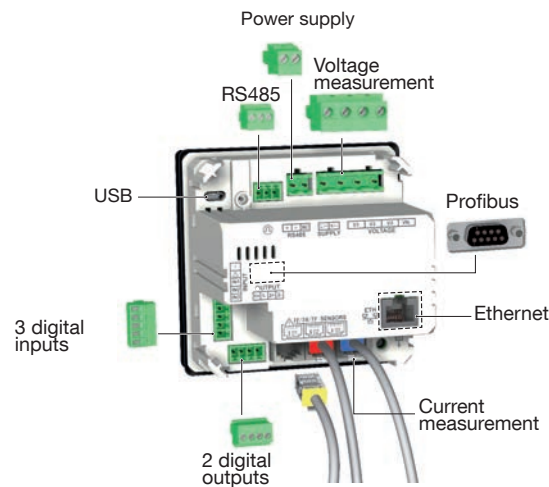

diris_988_a_1_en_cat.it

Dimensions (in/mm)

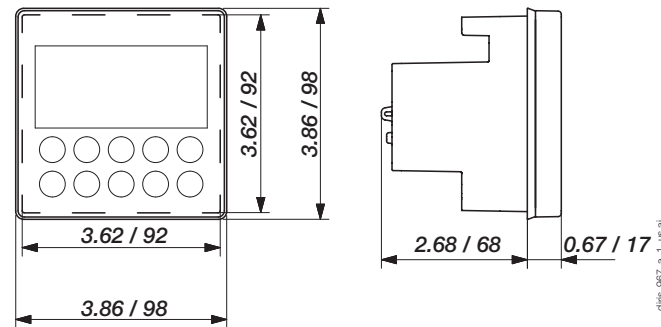

diris_967_a_1_us.ai

Current measurement

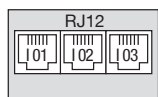

diris_989_a_1_x_cat.it

3 inputs supplied by the product

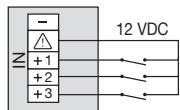

diris_971_a_1_x_cat.it

3 inputs with external power supply

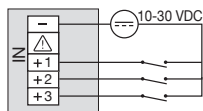

diris_972_a_1_x_cat.it

Voltage measurement and power supply

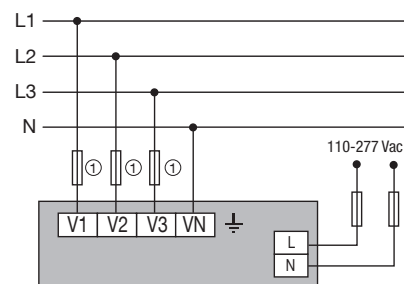

diris_977_a.ai

1. 0.5 A gG / 0.5 A class CC fuses.

2 outputs

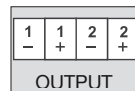

Ground



RS485

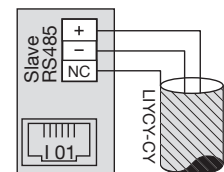

diris_b_024_b_1_x_cat.it

Current sensors

Associated current sensors

Various types of current sensors can be connected to the DIRIS A-40: solid-core (TE), split-core (TR/iTR) or Rogowski (TF). This range of sensors is suitable for all types of new or existing installations. A quick RJ12 connection makes wiring easy and reliable and prevents wiring errors. The DIRIS A-40 automatically recognizes the sensor type and rating. This guarantees the accuracy of the overall measurement chain (DIRIS A-40 + current sensors).

For more information on TE, TR/iTR, TF current sensors, refer to pages 348-355.

TE solid-core current sensors

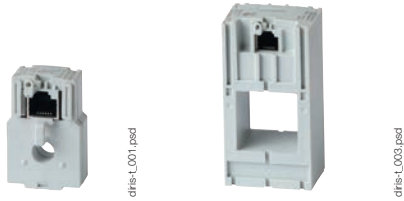

TR/iTR split-core current sensors

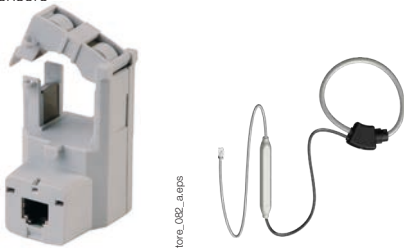

TE / TR/iTR / TF current sensors

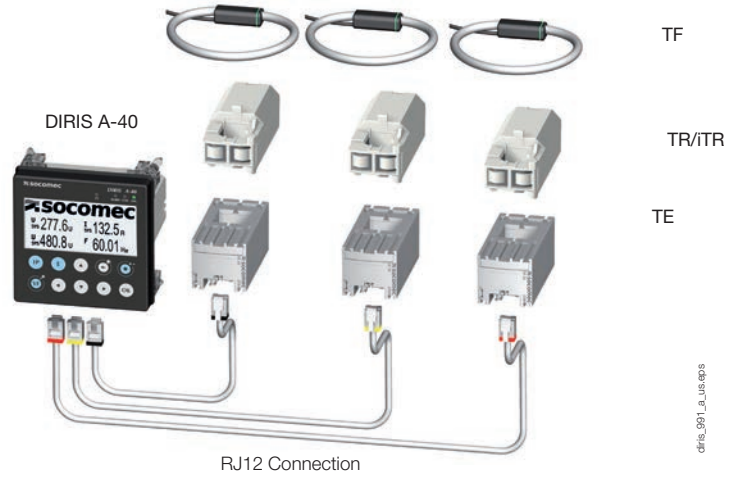

Voltage and current sensor connection examples

Three phase + Neutral

3P+N - 3 CT (1 three-phase load + calculated Neutral)

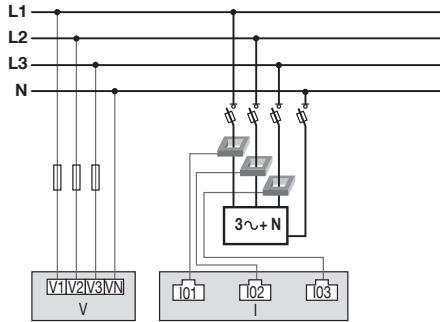

dfrs_973_a.ai

Three-phase

3P - 3CT (1 three-phase load)

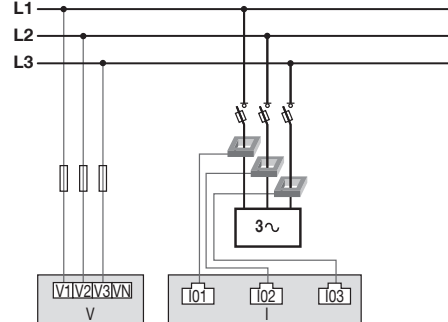

dfrs_974_a.ai

Three-phase

3P - 1CT (1 balanced three-phase load)

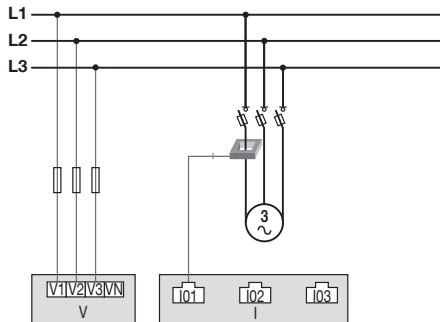

dfrs_975_a.ai

Single-phase

1P+N - 1CT (1 single-phase load)

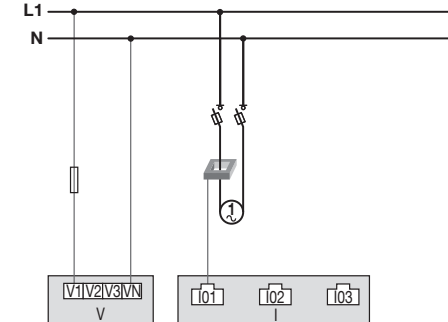

dfrs_976_a.ai

1.0.5 A class CC fuses.



DIRIS A-40

Multifunction power meter - panel mounted
Works with RJ12 smart current sensors

DIRIS A-40 characteristics

Mechanical characteristics

Type of screen	Capacitive touch-screen technology, 10 keys
Screen resolution	350 x 160 pixels
Ingress Protection	IP65, front face

Electrical characteristics

Power supply input	110-277 VAC L-N / 277-400 VAC L-L - CAT III 120-300 VDC - CAT III
Power consumption	5 VA AC / 1.5 VA DC (4825 0500) 8 VA AC / 2.5 VA DC (4825 0501 & 4825 0502)
Connection	Removable screw terminal block, 2 positions, AWG 14 ... AWG 20 / 0.5 ... 2.5 mm ² solid cable or stranded cable with ferrule
Voltage measurement input	50-300 VAC (Ph/N) - 87-520 VAC (Ph/Ph) - CAT III
Electrical Network (Service) type	Single-Phase - Two-Wire, Line-to-Neutral Single-Phase - Two-Wire, Line-to-Line Single-Phase - Three-Wire (Split-Phase) Three-Phase - Three-Wire (Delta) Three-Phase - Four-Wire (Wye)
Frequency range	45 ... 65 Hz
Input consumption	≤ 0.1 VA
Connection	Removable screw terminal block, 4 positions, AWG 14 ... AWG 24 / 0.25 ... 2.5 mm ² solid cable or stranded cable with ferrule

Measuring characteristics

Voltage measurement	
Sampling rate	9.6 kHz
Voltage measurement accuracy	Class 0.2
Frequency measurement accuracy	Class 0.02
Current measurement	
Number of current inputs	3
Associated current sensors	Solid-core TE, split-core TR/ITR, flexible TF current sensors
Connection type	Socomec RJ12 cables
Current measurement accuracy	Class 0.2 DIRIS A-40 alone Class 0.5 with TE, ITR, TF sensors Class 1 with TR sensors

Current measurement

Active Power/Energy accuracy	Class 0.2 DIRIS A-40 alone Class 0.5 with TE, ITR, TF sensors Class 1 with TR sensors
Reactive Power accuracy	Class 1 with TE, ITR, TF sensors Class 2 with TR sensors
Reactive Energy accuracy	Class 2 with TE, TR/ITR, TF sensors

Digital inputs

Number of digital inputs	3
Digital input type	Optocoupler with internal (12 VDC ± 10%) or external (12-24 VDC ± 20%) polarisation
Function	Logical status, pulse meter, multi-tariff
Connection	Removable screw terminal block, 5 positions, stranded or solid AWG 15 to AWG 24 / 0.2 to 1.5 mm ² cable

Digital outputs

Number of digital outputs	2
Relay type	Optocoupler 30 VDC, 20 mA max. - SELV
Function	Manual command, pulse output, load shedding, alarm report
Connection	Removable screw terminal block, 4 positions, stranded or solid AWG 13 to AWG 24 / 0.2 to 2.5 mm ² cable

Communication characteristics

RS485

Connection type	Half-Duplex, 2-3 wires
Protocol	Modbus RTU
Baudrate	9600 bds - 115200 bds

Ethernet

Connection type	RJ45 10/100 Mbs
Protocol	Modbus TCP/IP, BACnet IP, HTTP, FTP, SMTP

USB

Connection type	USB Type Micro-B
Protocol	Modbus RTU over USB
Function	Firmware upgrade and configuration

Environmental characteristics

Storage temperature	-13 to +185 °F / -25 to +85°C
Operating temperature	+14 to +158 °F / -10 to +70°C
Humidity	0% to 97% RH / +131°F/+55°C, non condensing
Operating altitude	≤ 6560 ft / 2000 m

Expert Services

Our service engineers are an essential part of our team, and they are dedicated to ensuring your power monitoring system provides accurate and reliable measurements to your EPMS software or SCADA system. Our services include:

- > Site audits to verify the proper wiring of your system
- > Personnel training on how to configure, operate and maintain power monitoring equipment and associated software
- > Remote and on-site commissioning to ensure that your system is up and running quickly, with peace of mind.

For further information, please contact your nearest SOCOMEC branch.



References

DIRIS A power meters		
DIRIS A-40	RS485 Modbus RTU	4825 0500
DIRIS A-40	RS485 Modbus RTU + Ethernet Modbus TCP & BACnet IP	4825 0501
DIRIS A-40	RS485 Modbus RTU + Profibus DPV1	4825 0502

Accessories	Sold in multiples of	Reference
3-pole RM Class CC fuse holder to protect voltage inputs	4	5705 0003
2-pole RM Class CC fuse holder to protect power supply input	6	5701 0002
1A/5A secondary CT adapter with RJ12 output	1	4829 0599
6.5-ft USB Cable for configuration - Type A to Type Micro-B	1	4829 0050

RJ12 Solid-core current sensors ⁽¹⁾				
Model	Nominal current range (A)	Real range covered (A)	Window size (in/mm)	Reference
TE-18	5 ... 20	0.1 ... 24	Ø 0.33 / 8.6	4829 0500
TE-18	25 ... 63	0.5 ... 75	Ø 0.33 / 8.6	4829 0501
TE-25	40 ... 160	0.8 ... 192	0.53 x 0.53 / 13.5 x 13.5	4829 0502
TE-35	63 ... 250	1.26 ... 300	0.82 x 0.82 / 21 x 21	4829 0503
TE-45	160 ... 630	3.2 ... 756	1.22 x 1.22 / 31 x 31	4829 0504
TE-55	400 ... 1000	8 ... 1200	1.61 x 1.61 / 41 x 41	4829 0505
TE-90	600 ... 2000	12 ... 2400	2.52 x 2.52 / 64 x 64	4829 0506

(1) Refer to pages 348-351 for more information on TE current sensors

RJ12 Split-core current sensors ⁽²⁾				
Model	Nominal current range (A)	Real range covered (A)	Window size (in/mm)	Reference
TR-10 / iTR-10	25 ... 63	0.5 ... 75.6	Ø 0.39 / 10	4829 0555 / 4829 0655
TR-14 / iTR-14	40 ... 160	0.8 ... 192	Ø 0.55 / 14	4829 0556 / 4829 0656
TR-21 / iTR-21	63 ... 250	1.26 ... 300	Ø 0.83 / 21	4829 0557 / 4829 0657
TR-32 / iTR-32	160 ... 600	3.2 ... 720	Ø 1.26 / 32	4829 0558 / 4829 0658

(2) Refer to pages 352-353 for more information on TR/iTR current sensors

RJ12 Flexible Rogowski current sensors ^{(3) (4)}				
Model	Nominal current range (A)	Real range covered (A)	Window size (in/mm)	Reference
TF-40	100 ... 400	2 ... 480	Ø 1.57 / 40	4829 0573
TF-80	150 ... 600	3 ... 720	Ø 3.15 / 80	4829 0574
TF-120	400 ... 2000	8 ... 2400	Ø 4.72 / 120	4829 0575
TF-200	600 ... 4000	12 ... 4800	Ø 7.87 / 200	4829 0576
TF-300	1600 ... 6000	32 ... 7200	Ø 11.81 / 300	4829 0577
TF-600	1600 ... 6000	32 ... 7200	Ø 23.62 / 600	4829 0578
Set of 3 RJ12 female/female connectors for RJ12 lead extension between power meter and TF sensor				4829 0670

(3) TF Rogowski sensors come with a 6-ft cable lead with RJ12 male connector

(4) Refer to pages 354-355 for more information on TF current sensors

RJ12 sensor lead cables	Cable length (ft / m)										
	0.32/0.1	0.64/0.2	0.96/0.3	1.64/0.5	3.3/1	6.5/2	9.84/3	16.4/5	22.9/7	32.8/10	164/50 reel + 100 connectors
Number of cables	Reference	Reference	Reference	Reference	Reference	Reference	Reference	Reference	Reference	Reference	Reference
1	-	-	-	-	-	-	-	4829 0602	-	4829 0603	4829 0601
3	4829 0580	4829 0581	4829 0582	4829 0595	4829 0583	4829 0584	4829 0606	4829 0607	4829 0608	4829 0609	-
4	-	-	-	4829 0596	4829 0588	4829 0589	-	-	-	-	-
6	4829 0590	4829 0591	4829 0592	4829 0597	4829 0593	4829 0594	-	-	-	-	-

Commissioning		Reference
1/2 day remote commissioning	Remote commissioning including installation verification, programming and communication testing	9230100027
1/2 day on-site commissioning	On-site commissioning including installation verification, programming and communication testing	9230100004

DIRIS B

Multifunction power meter - DIN-rail mounted
Works with RJ12 smart current sensors



DIRIS B-10 / B-30
RS485



Function

The **DIRIS B** is a DIN-rail mounted power monitoring device compatible with TE/TR/iTR/TF smart current sensors, suitable for new or existing electrical installations.

The 4 independent RJ12 current inputs allow the DIRIS B to monitor 1 three-phase circuit and use a dedicated current sensor for the neutral, or 4 single-phase loads.

Advantages

Plug & Play

- Color-coded RJ12 cables for easy phase identification when wiring current sensors to the DIRIS B.
- Automatic detection of current sensor type and rating.
- Using low-voltage mV current sensors, no shorting blocks are needed, they can be disconnected safely under load.

Better than revenue grade

- Class 0.2 DIRIS B meter accuracy according to ANSI C12.20.
- Class 0.5 system accuracy (DIRIS B + TE/iTR/TF current sensors) from 2% to 120% of rated current.

Bi-Directional Metering

The DIRIS B measures the flow of electricity in both directions (import / export).

The DIRIS B has 2 native digital input for additional versatility and includes Modbus RTU serial communication to report measurements to external management systems.

Additional digital & analog input/output modules can extend the basic functional scope of the DIRIS B. An optional display can also be plugged to the meter for local visualization on panel doors.

Multi-circuit

- Four independent current sensor inputs allow you to configure multiple circuits in order to optimize the number of power meters per installation.

Versatile

- The DIRIS B can be connected to:
 - a remote DIRIS D-30 screen for local display of measurement data on the panel door.
 - optional digital or analog input/output modules, as well as temperature input modules.
 - DIRIS Digiware M-50/M-70 gateways for centralization and communication of data via Ethernet. DIRIS Digiware M-70 embeds WEBVIEW-M, a webserver for remote visualization of measurement data.

The solution for

- > Industry
- > Building
- > Renewables



Strong points

- > Plug & Play
- > Better than revenue grade
- > Multi-circuit
- > Versatile

Integrated technologies



For more information see our website
www.socomec.us

Conformity to standards

- > UL 61010-1, CSA-C22.22 No. 61010-1, Guide FTRZ/PICQ, File E257746



- > ANSI C12.20

- > PBI Meter per CA Energy Commission



- > IEC 61557-12



- > ISO 14025



Create your project

- > Find the best DIRIS architecture for your power metering & monitoring projects:
www.meter-selector.com



		
DIRIS B	DIRIS B-10	DIRIS B-30
Current sensor technology	RJ12	RJ12
General		
Format	DIN Rail	DIN Rail
Number of current sensor inputs	4	4
Available enclosed		•
Electrical		
Power supply	110 - 240 VAC	110 - 240 VAC
Voltage measurement	50 - 300 VAC L-N 87 - 520 VAC L-L	50 - 300 VAC L-N 87 - 520 VAC L-L
Communication		
RS485 Modbus RTU	•	•
Digital Input / Output	2 / 0	2 / 0
Analog Input / Output	0 / 0	0 / 0
Energy metering		
±kWh, ±kvarh, kVAh	•	•
ΣP (kW), ΣQ (kvar), ΣS (kVA), PF	•	•
P (kW), Q (kvar), S (kVA), PF per phase		•
Predictive Power		•
Load curves / demand profiles		•
Peak Demand		•
Multi-tariff	8	8
Multi - measurement		
U12, U23, U31, V1, V2, V3, f	•	•
U system, V system	•	•
I1, I2, I3, In, I system	•	•
Unbalance U, V, I	•	•
Phi, cos Phi, tan Phi	•	•
Power quality		
THD U, V, I	•	•
Individual Harmonics U, V, I (up to 63rd)		•
Crest Factor I1, I2, I3		•
K-Factor		•
PQ Events (sags, swells, interruptions, overcurrents)		•
Alarms		
Measurement thresholds		•
System alarms	•	•
Protective device	•	•
Logical (digital input status)		•
History		
Average Values		•
Reference	4829 0010	4829 0000

DIRIS B

Multifunction power meter - DIN-rail mounted

Works with RJ12 smart current sensors

Accessories

DIRIS B sealing cover

- Prevents access to the cabling of the power meter.

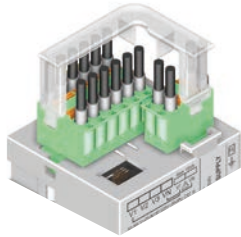

USB configuration cable (6.56 ft / 2 m)

- Configuration and firmware upgrade of the DIRIS B power meter can be achieved using Easy Config System via a direct USB connection.

DIRIS D-30 display

DIRIS D-30



Connection



Optional modules

DIRIS O

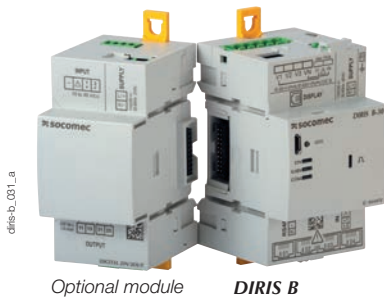

Optional modules (4 max.)*

- Digital inputs/outputs
- Analog inputs/outputs
- Temperature inputs

* maximum 4 optional modules with maximum 1 temperature module.



DIRIS O-iod

- 2 digital inputs to count pulses from utility meters or to monitor change of status of auxiliary contacts.
- 2 digital outputs can be connected to configurable alarms warning of exceeded thresholds (power, current, etc.) or can be piloted remotely.



DIRIS O-ioa

- 2 analog inputs (4-20 mA) to collect measurements from analog sensors (pressure, humidity, temperature, etc.)
- 2 analog outputs (4-20 mA) to report measurements (power, currents, etc.)



DIRIS O-it

- 3 temperature inputs to be connected to PT100 or PT1000 sensors.
- Ambient air temperature.

DIRIS B terminals

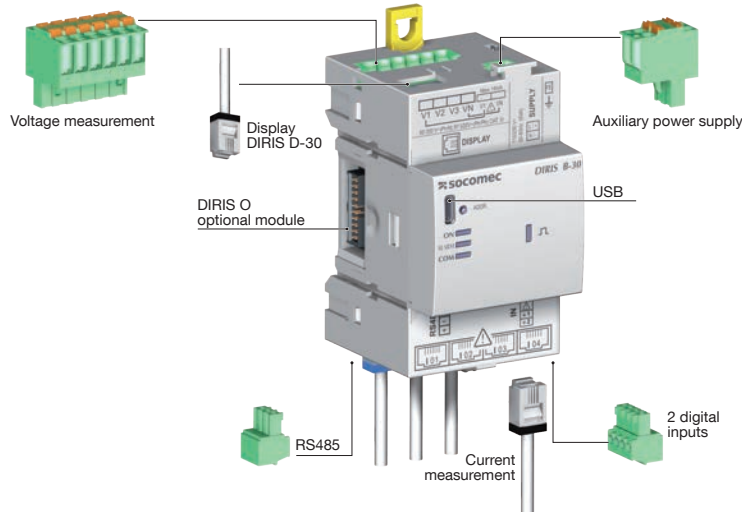

dfrs-b_027_b_1_ghb_cat

Current measurement

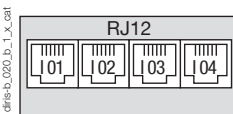

Voltage measurement and auxiliary power supply

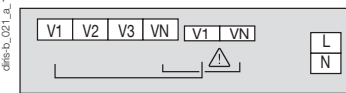

2 inputs supplied by the product

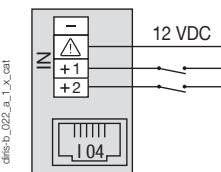

dfrs-b_022_a_1_x_cat

Self supply

Easy connection of the power supply from the measurement terminal (specific terminals)

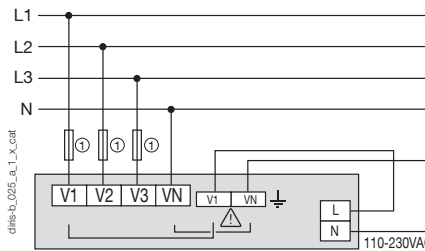

1. Fuses 0.5 A class CC.

dfrs-b_023_a_1_x_cat

2 inputs with external power supply

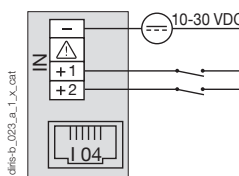

Separate power supply

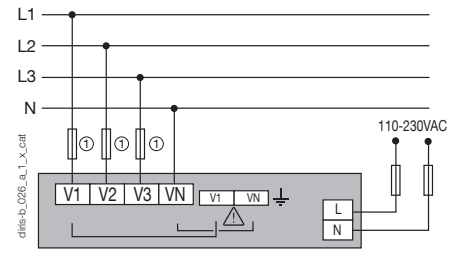

1. Fuses 0.5 A class CC.

dfrs-b_024_b_1_x_cat

RS485

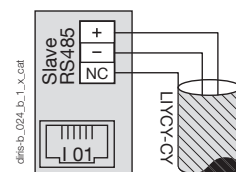

RJ9 for DIRIS D-30 (self-supply and data)

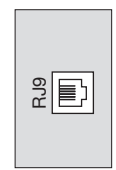

dfrs-b_019_a_1_x_cat

Terminals of optional DIRIS O modules

Optional module power supply

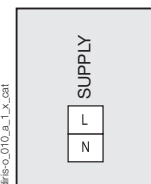

dfrs-o_010_a_1_x_cat

DIRIS O-iod

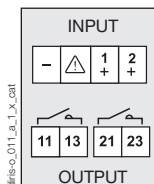

dfrs-o_011_a_1_x_cat

DIRIS O-ioa

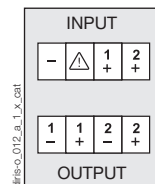

dfrs-o_012_a_1_x_cat

DIRIS O-it

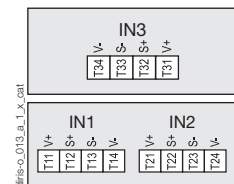

dfrs-o_013_a_1_x_cat

DIRIS B

Multifunction power meter - DIN-rail mounted

Works with RJ12 smart current sensors

Current sensors

Associated current sensors

Various types of current sensors can be connected to the DIRIS B: Solid-core TE , split-core TR/ITR , flexible TF current sensors. This range of sensors can be adapted to all types of new or existing installations. A rapid RJ12 connection makes wiring easy and reliable and prevents wiring errors. The DIRIS B automatically recognizes the type of sensor used and its current rating. This guarantees the accuracy of the overall measurement chain (DIRIS B + current sensors).
For more information on TE, TR/ITR, TF current sensors, refer to pages 348-355.

TE solid-core current sensors

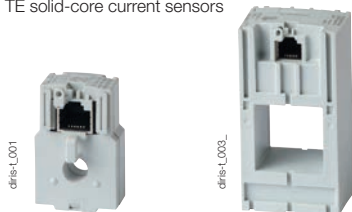

TR/ITR split-core current sensors



TF flexible current sensors



TE / TR/ITR / TF current sensors

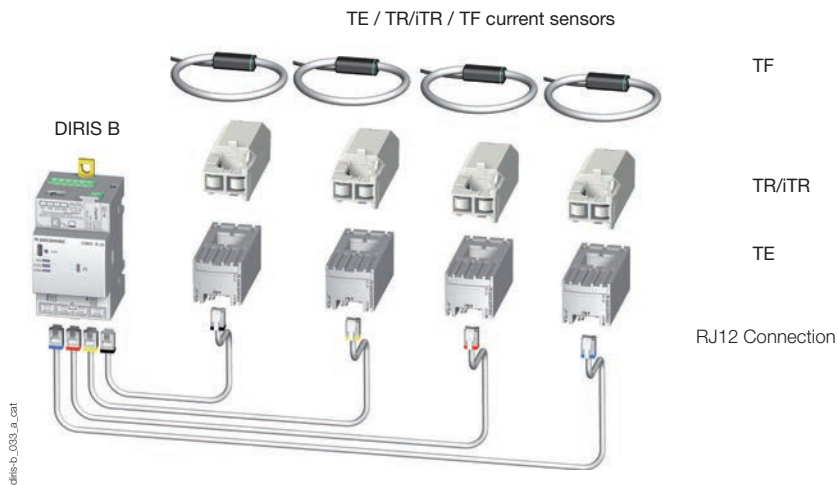

Voltage and current sensor connection examples

Three phase + neutral

3P+N - 4CTs (measurement for 1 three-phase load + Neutral)

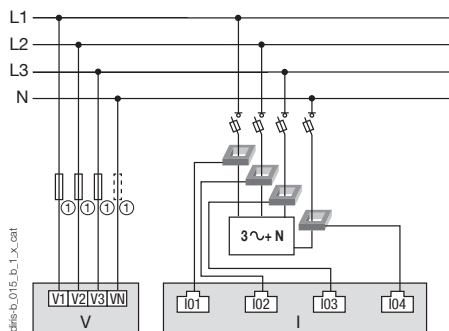

Three-phase

3P - 2CTs (2 three-phase loads without neutral)

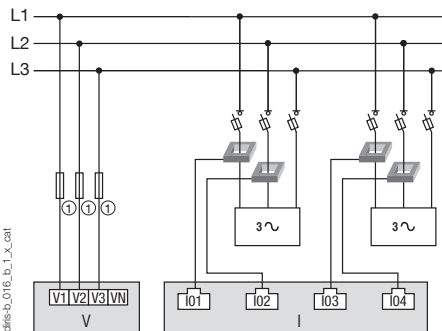

Three-phase

3P+N - 3CTs & 1P+N - 1CT (1 three-phase load & 1 single-phase load)

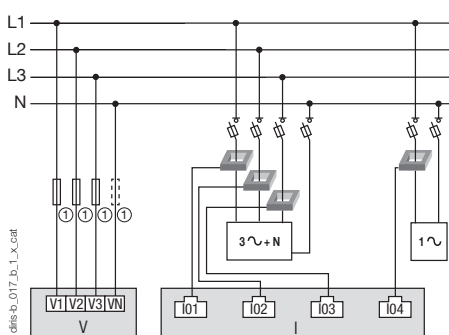

Single-phase

1P+N-1CT (4 single-phase loads)

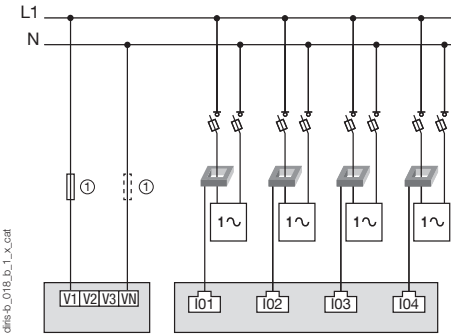

1. Fuses 0.5 A class CC.

In case of self-supply, a fuse must be added on the neutral.



CT: Current sensors

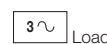

Load

Dimensions (in/mm)

DIRIS B

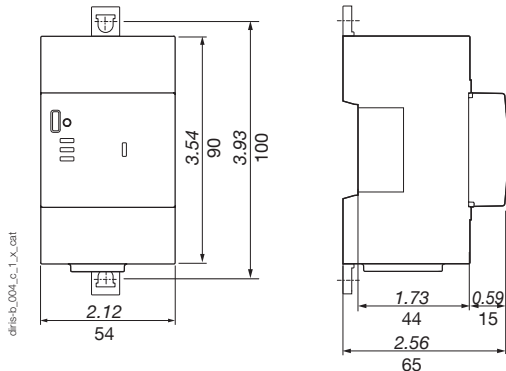

DIRIS O optional modules

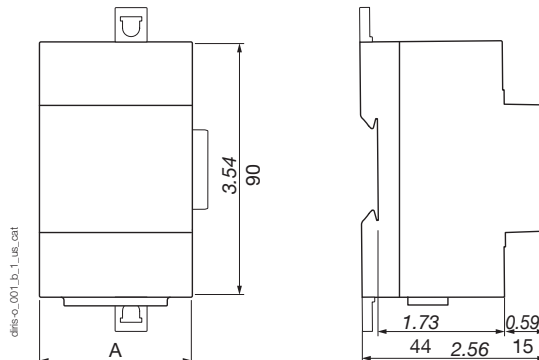

DIRIS O optional modules

DIRIS O-iod - DIRIS O-ica - DIRIS O-it

A (in / mm)

1.77 / 45

DIRIS D-30

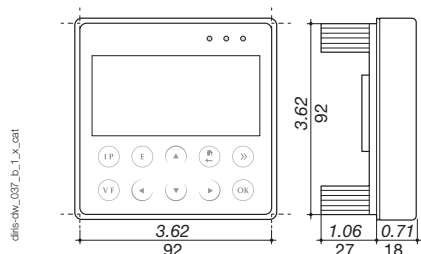

Communication architecture

Example of communication architecture with DIRIS Digiware M-70 gateway and WEBVIEW-M embedded web server.

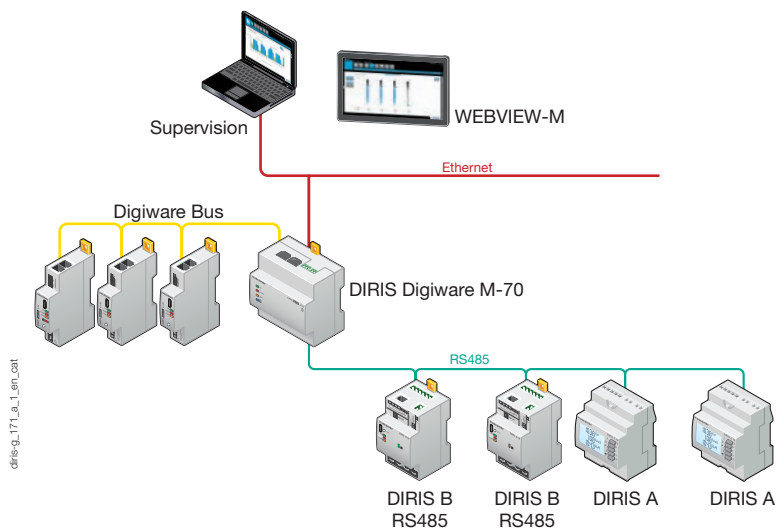

DIRIS B

Multifunction power meter - DIN-rail mounted

Works with RJ12 smart current sensors

DIRIS B characteristics

Electrical characteristics	
Auxiliary power supply	
AC voltage	110-230 VAC $\pm 15\%$ (Ph/N ou Ph/Ph) Cat III
Frequency	50/60 Hz
Consumption	< 2 VA without display < 6 VA with display
Connection	Removable spring-cage terminal, 2 x 2 positions, AWG 10 ... 24 / 0.5 ... 2.5 mm ² solid cable or AWG 15 ... 30 / 0.25 ... 1.5 mm ² stranded cable with ferrule
Measurement characteristics	
Energy and power measurement	
Accuracy	Class 0.2 DIRIS B alone
Active energy and active power	Class 0.5 with TE, iTR or TF current sensors
	Class 1 with TR current sensors
Accuracy Reactive energy	Class 2 with TE, TR/iTR or TF current sensors
Power factor measurement	
Accuracy	Class 0.5 with TE, iTR or TF current sensors
	Class 1 with TR current sensors
Voltage measurement	
Voltage range	50-300 VAC (Ph/N) - 87-520 VAC (Ph/Ph) - CAT III
Frequency range	45 ... 65 Hz
Frequency accuracy	Class 0.02
Electrical Network type	Single-phase / Two-phase / Two-phase with neutral / Three-phase / Three-phase with neutral
Measurement by voltage transformer	Primary: 400 000 VAC Secondary: 60, 100, 110, 173, 190 VAC
Input consumption	≤ 0.1 VA
Permanent overload	300 VAC Ph/N
Voltage measurement accuracy	Class 0.2
Connection	Removable spring-cage terminal, 2 x 6 positions, AWG 10 ... 24 / 0.5 ... 2.5 mm ² solid cable or AWG 15 ... 30 / 0.25 ... 1.5 mm ² stranded cable with ferrule
Current measurement	
Number of current inputs	4
Associated current sensors	Solid-core TE , split-core TR/iTR , flexible TF current sensors
Accuracy	Class 0.2 DIRIS B alone
	Class 0.5 with TE, iTR or TF current sensors
	Class 1 with TR current sensors
Connection	Specific Socomec RJ12 cables
Input characteristics	
Number	2
Type / Power supply	Optocoupler internal polarisation (12 VDC $\pm 10\%$) or external polarisation (10-30 VDC $\pm 10\%$)
Input function	Logic status, pulse meter or synchronization pulse status (input 1)
Communication characteristics	
RS485	
Link	RS485
Connection type	Half-Duplex, 2 wires
Protocol	Modbus RTU
Speed	1200 ... 115200 bauds
USB	
Protocol	MODBUS RTU over USB
Function	Configuration of DIRIS Digiware modules
Connection	Micro-B type USB connector
Environmental characteristics	
Operating temperature	+14 ... +158 °F / -10 ... +70 °C
Storage temperature	-13 ... +185 °F / -25 ... +85 °C
Operating humidity	131 °F / 55 °C / 97% relative humidity
Operating altitude	≤ 6560 ft / 2000 m
Vibration	1G from 10 to 100Hz

DIRIS D-30 display characteristics

Mechanical characteristics	
Screen type	Capacitive touch-screen technology, 10 keys
Screen resolution	350 x 160 pixels
Degree of protection	IP65 (front face)
Single product connection	
RJ9	Self-supply and data
Micro-B USB	Firmware Upgrade
Environment	
Storage temperature (°C)	-4 ... +158 °F / -20 ... +70°C
Operating temperature (°C)	-4 ... +158 °F / -20 ... +70°C
Humidity	95 % at 104 °F / 40°C
Installation category	CAT III
Degree of pollution	2

DIRIS O optional modules characteristics

Power supply ⁽¹⁾	
AC voltage	110-230 VAC $\pm 15\%$
Frequency	50/60 Hz

(1) No power supply on DIRIS O-it.

DIRIS O-iod - 2 digital inputs/2 digital outputs	
Number of inputs	2 per optional modules - max. 4 optional modules
Type	Optocoupler internal polarisation (12 VDC $\pm 10\%$) or external polarisation (10-30 VDC $\pm 10\%$)
Function	Logic status or pulse metering
Number of outputs	2 per optional modules - max. 4 optional modules
Type	Relay / 230VAC $\pm 15\%$ - 1 A
Function	Configurable alarm (current, power,...) on threshold overruns or remote controlled status
Inputs/Outputs connection	Removable screw terminal, 4 positions, AWG 15 ... 35 / 0.14 to 1.5 mm ² stranded or solid cable

DIRIS O-ioa - 2 analog inputs/2 analog outputs	
Number of inputs	2 per optional modules - max. 4 optional modules
Type	4-20 mA
Function	Connection of analog sensors (pressure, humidity, temperature...)
Number of outputs	2 per optional modules - max. 4 optional modules
Type	4-20 mA
Function	Transmission of measurement image (current, power...) to PLCs

DIRIS O-it - 3 temperature inputs	
Number of inputs	3 external inputs + 1 measurement for ambient temperature
Dynamic	-4 ... 302 °F / -20 ... 150 °C
Type	PT100 or PT1000

References

DIRIS B power meters		Reference
DIRIS B-10	DIN rail Power Monitoring Device with Modbus RS485 communication	4829 0010
DIRIS B-30	DIN rail Power Monitoring Device with Modbus RS485 communication	4829 0000
DIRIS O optional modules		Reference
DIRIS O-iod	2 digital inputs / 2 digital outputs	4829 0030
DIRIS O-ioa	2 analog inputs / 2 analog outputs 4-20 mA	4829 0031
DIRIS O-it	3 temperature inputs PT 100 / PT 1000	4829 0032
Remote display		Reference
DIRIS D-30 - Single-point display		4829 0030
RJ9 cable for DIRIS D-30 display - 4.92 ft / 1.5 m		4829 0031
RJ9 cable for DIRIS D-30 display - 9.84 ft / 3 m		4829 0032
Accessories		Reference
Sealing cover for DIRIS B I/O terminals		4829 0200
3-pole RM Class CC fuse holder to protect voltage inputs		4829 0280
2-pole RM Class CC fuse holder to protect power supply input		4829 0281
1A/5A secondary CT adapter with RJ12 output		4829 0049
6.5-ft USB Cable for configuration - Type A to Type Micro-B		4829 0050

RJ12 Solid-core current sensors ⁽¹⁾

Model	Nominal current range (A)	Real range covered (A)	Window size (in/mm)	Reference
TE-18	5 ... 20	0.1 ... 24	∅ 0.33 / 8.6	4829 0500
TE-18	25 ... 63	0.5 ... 75	∅ 0.33 / 8.6	4829 0501
TE-25	40 ... 160	0.8 ... 192	0.53 x 0.53 / 13.5 x 13.5	4829 0502
TE-35	63 ... 250	1.26 ... 300	0.82 x 0.82 / 21 x 21	4829 0503
TE-45	160 ... 630	3.2 ... 756	1.22 x 1.22 / 31 x 31	4829 0504
TE-55	400 ... 1000	8 ... 1200	1.61 x 1.61 / 41 x 41	4829 0505
TE-90	600 ... 2000	12 ... 2400	2.52 x 2.52 / 64 x 64	4829 0506

(1) Refer to pages 348-351 for more information on TE current sensors

RJ12 Split-core current sensors ⁽²⁾

Model	Nominal current range (A)	Real range covered (A)	Window size (in/mm)	Reference
TR-10 / iTR-10	25 ... 63	0.5 ... 75.6	∅ 0.39 / 10	4829 0555 / 4829 0655
TR-14 / iTR-14	40 ... 160	0.8 ... 192	∅ 0.55 / 14	4829 0556 / 4829 0656
TR-21 / iTR-21	63 ... 250	1.26 ... 300	∅ 0.83 / 21	4829 0557 / 4829 0657
TR-32 / iTR-32	160 ... 600	3.2 ... 720	∅ 1.26 / 32	4829 0558 / 4829 0658

(2) Refer to pages 352-353 for more information on TR/iTR current sensors

RJ12 Flexible Rogowski current sensors ^{(3) (4)}

Model	Nominal current range (A)	Real range covered (A)	Window size (in/mm)	Reference
TF-40	100 ... 400	2 ... 480	∅ 1.57 / 40	4829 0573
TF-80	150 ... 600	3 ... 720	∅ 3.15 / 80	4829 0574
TF-120	400 ... 2000	8 ... 2400	∅ 4.72 / 120	4829 0575
TF-200	600 ... 4000	12 ... 4800	∅ 7.87 / 200	4829 0576
TF-300	1600 ... 6000	32 ... 7200	∅ 11.81 / 300	4829 0577
TF-600	1600 ... 6000	32 ... 7200	∅ 23.62 / 600	4829 0578
Set of 3 RJ12 female/female connectors for RJ12 lead extension between power meter and TF sensor				4829 0670

(3) TF Rogowski sensors come with a 6-ft cable lead with RJ12 male connector

(4) Refer to pages 354-355 for more information on TF current sensors

RJ12 sensor lead cables	Cable length (ft / m)										
	0.32/0.1	0.64/0.2	0.96/0.3	1.64/0.5	3.3/1	6.5/2	9.84/3	16.4/5	22.9/7	32.8/10	164/50 reel + 100 connectors
Number of cables	Reference	Reference	Reference	Reference	Reference	Reference	Reference	Reference	Reference	Reference	Reference
1	-	-	-	-	-	-	-	4829 0602	-	4829 0603	4829 0601
3	4829 0580	4829 0581	4829 0582	4829 0595	4829 0583	4829 0584	4829 0606	4829 0607	4829 0608	4829 0609	-
4	-	-	-	4829 0596	4829 0588	4829 0589	-	-	-	-	-
6	4829 0590	4829 0591	4829 0592	4829 0597	4829 0593	4829 0594	-	-	-	-	-

Commissioning		Reference
1/2 day remote commissioning	Remote commissioning including installation verification, programming and communication testing	9230100027
1/2 day on-site commissioning	On-site commissioning including installation verification, programming and communication testing	9230100004

DIRIS A-30

Multifunction power meter - Panel mounted
Works with 5A secondary current transformers



DIRIS A-30

Function

The DIRIS A-30 is a panel mounted multifunction power meter for low voltage electrical installations, compatible with 1A or 5A secondary CTs.

The device is easy to use thanks to its large backlit LCD display and 6 keys used to view readings and to configure the power meter.

Additional plug-in modules can be connected to the back of the power meter to extend its basic functional scope.

Advantages

User-friendly operation

With its large backlit multiple-display screen and 6 pushbuttons, the DIRIS A-30 is easy to use.

Customizable

The DIRIS A-30 can be equipped with additional modules that give the user flexibility throughout the service life of the product. Communication modules and additional digital or analog inputs/outputs can be used to increase its range of functionality.

Functional diagram

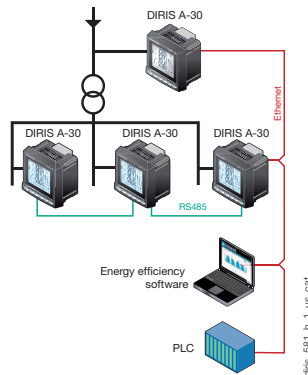

Compliant with ANSI C12.20

ANSI C12.20 and IEC 61557-12 are high-level standards for power metering & monitoring devices. Compliance with these standards ensures equipment performance and reliability in terms of accuracy, as well as mechanical, EMC, temperature etc.

Bi-directional metering

DIRIS A-30 can measure the flow of electricity in both directions (import / export).

The solution for

- > Industry
- > Building
- > Infrastructures



Strong points

- > User-friendly operation
- > Customizable
- > Compliant with ANSI C12.20 and IEC 61557-12

Compliance with standards

- > UL 61010-1
CSA-C22.2 No. 61010-1
Guide PICQ
File E257746



- > ANSI C12.20
- > IEC 61557-12

Functions

Multi-measurement

- Currents
- instantaneous: I1, I2, I3, In, Isystem
- average/max average: I1, I2, I3, In
- Voltages & frequency
- instantaneous: V1, V2, V3, U12, U23, U31, F, Vsystem, Ussystem
- average/max average: V1, V2, V3, U12, U23, U31, F
- Powers
- instantaneous: 3P, ΣP, 3Q, ΣQ, 3S, ΣS
- max average: ΣP, ΣQ, ΣS
- predictive: (ΣP), (ΣQ), (ΣS)
- Power factors
- instantaneous: 3PF, ΣPF
- average/max average: ΣPF
- Kfactor

Metering

- Active energy: +/- kWh
- Reactive energy: +/- kvarh
- Apparent power: kVAh
- Hour Meter: ⌚

Harmonic analysis

- Total Harmonic Distortion
- Currents: thd I1, thd I2, thd I3, thd In
- Phase-to-neutral voltage: thd V1, thd V2, thd V3
- Phase-to-phase voltage: thd U12, thd U23, thd U31
- Individual harmonics up to 63rd
- Currents: HI1, HI2, HI3, HIn
- Phase-to-neutral voltage: HV1, HV2, HV3,

- Phase-to-phase voltages: HU12, HU23, HU31

Demand profiles

- Active & reactive power: ΣP+/-; ΣQ+/-
- Voltages & frequency: V1, V2, V3, U12, U23, U31, F

Events⁽¹⁾

- Alarms on all electrical parameters.

Communications

- RS485 (Modbus & Profibus-DP)
- Ethernet (Modbus/TCP or Modbus RTU)
- Ethernet with RS485 Modbus RTU gateway over TCP

Inputs/Outputs

- Pulse metering
- Remote control/command
- Alarm report
- Pulse report

Analog output

- Analog 0/4- 20 mA

Front panel



1. Backlit LCD display.
2. Pushbutton for currents and for connection correction function.
3. Pushbutton for voltages and frequency.
4. Pushbutton for active, reactive and effective powers and for power factor.
5. Pushbutton for maximum and average values for currents and power levels.
6. Pushbutton for harmonics.
7. Pushbutton for electrical energy meters, timers and impulse counters.

Hot swappable modules

DIRIS® A-30



Pulse outputs

2 configurable pulse outputs (type, weight and run) on \pm kWh, \pm kvarh and kVAh.



MODBUS® communication

RS485 link with MODBUS® protocol (speed up to 38400 baud).



PROFIBUS® DP communication

SUB-D9 link with PROFIBUS® DP protocol (speed up to 12 Mbaud).



Analogue outputs

You can connect a maximum of 2 modules, i.e. 4 analogue outputs. 2 outputs can be allocated to:

3I, In, 3V, 3U, F, \pm Σ P, \pm Σ Q, Σ S, Σ PFL/C, Isys, Vsys, Usys, Ppred, Qpred, Spred, T°C internal, T°C 1, T°C 2, T°C3 and to 30 VDC power supply.

2 inputs - 2 outputs

You can connect a maximum of 3 modules, i.e. 6 inputs / 6 outputs.

2 outputs can be allocated to:

- monitoring: 3I, In, 3V, 3U, F, \pm Σ P, \pm Σ Q, Σ S, Σ PFL/C, THD 3I, THD In, THD 3V, THD 3U, Ppred, Qpred, Spred, T°C internal, T°C 1, T°C2, T°C3 and of time counter,
- remote control,
- timed remote control,
- 2 inputs for pulse counting.



Storage capability

- Memory function up to max. 62 days for P+, P-, Q+, Q- with a TOP for internal or external synchronisation of 5, 8, 10, 15, 20, 30 and 60 minutes.
- Memory function for the last 10 timed and dated alarms.
- Memory function for the last min and max instantaneous values for 3U, 3V, 3I, In, F, Σ P \pm , Σ Q \pm , Σ S, THD 3U, THD 3V, THD, 3U, THD, 3V, THD, 3I, THD In.
- Memory function of average values 3U, 3V and F as a function of synchronisation (maximum 60 days).



Ethernet communication

- Ethernet link with MODBUS/TCP or MODBUS RTU over TCP.



Ethernet communication with RS485 MODBUS gateway

- Ethernet link with MODBUS/TCP or MODBUS RTU over TCP.
- Connect 1 to 247 RS485 MODBUS slaves.



DIRIS A-30

Multifunction power meter - Panel mounted

Works with 5A secondary current transformers

Electrical characteristics

Measurement of currents on insulated inputs (TRMS)	
Via CT primary	9,999 A
Via CT secondary	1 or 5 A
Measurement range	0 ... 11 kA
Input consumption	≤ 0,1 VA
Measurement updating period	1 s
Accuracy	0.2%
Permanent overload	6 A
Intermittent overload	10 I _n for 1 s
Voltage measurements (TRMS)	
Direct measurement between phases	50 ... 1039 VAC
Direct measurement between phase and neutral	28 ... 600 VAC
VT primary measurement	500,000 VAC
VT secondary measurement	60, 100, 110, 173, 190 VAC
Frequency	50 / 60 Hz
Input consumption	≤ 0,1 VA
Measurement updating period	1 s
Accuracy	0.2%
Current - voltage product	
Limitation for CT 1 A	10,000,000
Limitation for CT 5 A	10,000,000
Power measurement	
Measurement updating period	1 s
Accuracy	0.5%
Power factor measurement	
Measurement updating period	1 s
Accuracy	0.5%
Frequency measurement	
Measurement range	45 ... 65 Hz
Measurement updating period	1 s
Accuracy	0.1%
Energy accuracy	
Active (according to IEC 62053-22)	Class 0.5 S
Reactive (according to IEC 62053-23)	Class 2
Auxiliary power supply	
Alternative voltage	110 ... 400 VAC
AC tolerance	± 10 %
Direct current	120 ... 350 VDC / 12 ... 48 VDC
DC tolerance	± 20 % / - 6 ... + 20 %
Frequency	50 / 60 Hz
Power consumption	≤ 10 VA

Module 2 inputs - 2 outputs: outputs (alarms / control)	
Number of relays	2 ⁽¹⁾
Type	250 VAC - 5 A - 1150 VA
Module 2 inputs - 2 outputs: optical coupler inputs	
Number	2 ⁽¹⁾
Power supply	10 ... 30 VDC
Minimum width of signal	10 ms
Minimum length between 2 pulses	18 ms
Type	Optical couplers
Pulse output module	
Number of relays	2
Type	100 VDC - 0.5 A - 10 VA
Max. number of manoeuvres	≤ 10 ⁸
Analog output module	
Number of outputs	2 ⁽²⁾
Type	Insulated
Scale	0 / 4 ... 20 mA
Load resistance	600 Ω
Maximum current	30 mA
MODBUS communication module	
Link	RS485
Type	2 to 3 half duplex wires
Protocol	MODBUS [®] RTU
MODBUS [®] speed	4800 to 38400 baud
PROFIBUS DP communication module	
Link	SUB-D9
Protocol	PROFIBUS [®] DP
PROFIBUS [®] speed	9.8 kbaud ... 12 Mbaud
Ethernet communication module	
Connection technology	RJ45
Baud rate	10 base T / 100 base T
Protocol	MODBUS TCP or MODBUS RTU on TCP
Operating conditions	
Operating temperature range	+14 ... +131 °F / - 10 ... + 55 °C
Storage temperature	-4 ... +185 °F / - 20 ... + 85 °C
Relative humidity	95%

(1) Max. 3 modules per DIRIS A-30.

(2) Max. 2 modules per DIRIS A-30.

Dimensions (in/mm)

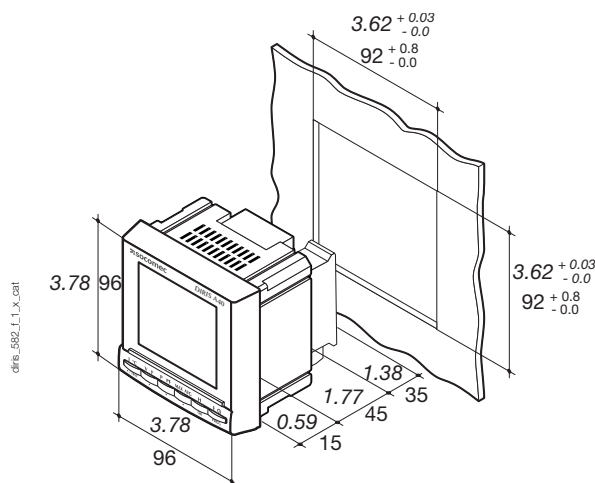

Type	Panel mounting
Dimensions W x H x D	3.78 x 3.78 x 2.36 in / 96 x 96 x 60 mm
Case degree of protection	IP30
Front degree of protection	IP52
Display type	Backlit LCD display
Type of terminal strips	Fixed or detachable
Section of connection for voltages and other terminals	AWG 34 ... 10 / 0.2 ... 2.5 mm ²
Section of connection for currents	AWG 20 ... 9 / 0.5 ... 6 mm ²
Weight	14.11 oz / 400 g

References

DIRIS A power meters		Reference
DIRIS A-30	110-400 VAC / 120-350 VDC power supply	4825 0403
DIRIS A-30	12-48 VDC power supply	4825 0405

Optional plug-in modules ⁽¹⁾	Reference
2 Pulse outputs	4825 0090
RS485 Modbus RTU communication	4825 0092
Profibus DP communication	4825 0205
2 Analog outputs	4825 0093
2 digital inputs / 2 digital outputs	4825 0094
Datalogging	4825 0097
Ethernet Modbus TCP communication ⁽²⁾	4825 0203
Ethernet communication + RS485 gateway ⁽²⁾	4825 0204

(1) Maximum 4 modules

(2) Dimensions: 2 slots.

Accessories	Sold in multiples of	Reference
IP65 protective cover	1	4825 0089
Integration Kit for 5.67 x 3.78 in / 144 x 96 mm cutout	1	4825 0088

Commissioning		Reference
1/2 day remote commissioning	Remote commissioning including installation verification, programming and communication testing	9230100027
1/2 day on-site commissioning	On-site commissioning including installation verification, programming and communication testing	9230100004

Expert Services

Our service engineers are an essential part of our team, and they are dedicated to ensuring your power monitoring system provides accurate and reliable measurements to your EPMS software or SCADA system.

Our services include:

- > Site audits to verify the proper wiring of your system
- > Personnel training on how to configure, operate and maintain power monitoring equipment and associated software
- > Remote and on-site commissioning to ensure that your system is up and running quickly, with peace of mind.

For further information, please contact your nearest SOCOMEC branch.



DIRIS A-20

Multifunction power meter - Panel mounted
Works with 5A secondary current transformers



DIRIS A-20

diris_981_a_front.eps

Function

The DIRIS A-20 is a panel mounted multifunction power meter for low voltage electrical installations, compatible with 1A or 5A secondary CTs.

The device is easy to use thanks to its large backlit LCD display and 4 keys used to view readings and configuration.

Additional plug-in modules can be connected to the back of the power meter to extend its basic functional scope.

Advantages

User-friendly operation

With its large backlit multiple-display screen with 4 pushbuttons, the DIRIS A-20 is easy to use.

Compliant with ANSI C12.20 and IEC 61557-12

ANSI C12.20 and IEC 61557-12 are high-level standards for power metering & monitoring devices. Compliance with these standards ensures equipment performance and reliability in terms of accuracy, as well as mechanical, EMC, temperature etc.

Customizable

Additional communication and input/output modules can extend the basic functional scope of this product. Equipped with additional modules, the DIRIS A-20 can provide the user with flexibility and expandability throughout the service life of the product.

Bi-directional metering

DIRIS A-20 can measure the flow of electricity in both directions.

Functional diagram

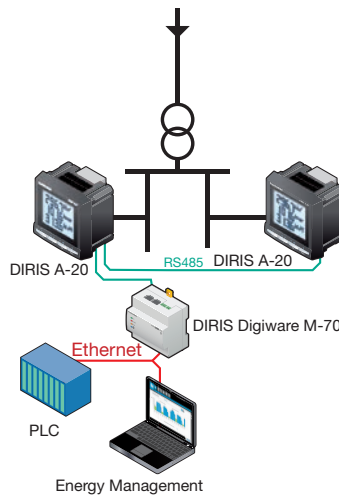

DIRIS_5716_L1_en_cat

The solution for

- > Industry
- > Infrastructures
- > Building



Strong points

- > User-friendly operation
- > Compliant with ANSI C12.20 and IEC 61557-12
- > Customizable
- > Bi-directional metering

Compliance with standards

- > UL 61010-1
CSA-C22.2 No. 61010-1
Guide PICQ
File E257746



- > ANSI C12.20
- > IEC 61557-12



Functions

Multi-measurement

- Currents
 - instantaneous: I1, I2, I3, In
 - maximum average: I1, I2, I3, In
- Voltages & frequency
 - instantaneous: V1, V2, V3, U12, U23, U31, F
- Powers
 - instantaneous: 3P, ΣP, 3Q, ΣQ, 3S, ΣS
 - maximum average: ΣP, ΣQ, ΣS
- Power factors
 - instantaneous: 3PF, ΣPF

Metering

- Active energy: +/- kWh
- Reactive energy: +/- kvarh
- Hour Meter: ⌚

Harmonic analysis

- Total harmonic distortion (rank 51)
 - Currents: thd I1, thd I2, thd I3
 - Phase-to-neutral voltage: thd V1, thd V2, thd V3
 - Phase-to-phase voltage: thd U12, thd U23, thd U31

Events

Alarms on all electrical parameters

Communications⁽¹⁾

RS485 with MODBUS protocol

Output

- Equipment control
- Alarm report
- Pulse report

Input

- Information report from a dry external contact
(1) Available as an option (see the following pages).

Front panel



1. Backlit LCD display
2. Pushbutton for currents (instantaneous and maximum), THD currents and the connection correction function.
3. Pushbutton for voltages, frequency and THD voltages.
4. Pushbutton for power (instantaneous and maximum), active, reactive and effective, power factor.
5. Pushbutton for energy sources and timer counter.

Dimensions (in/mm)

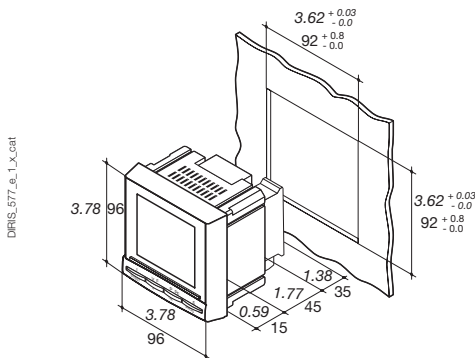

Type	Panel Mounting
Dimensions L x H x P	3.78 x 3.78 x 2.36 in / 96 x 96 x 60 mm
Case degree of protection	IP30
Front degree of protection	IP52
Display type	Backlit LCD
Type of terminal strips	Fixed or removable
Section for connection of voltages and other terminals	AWG 34 ... 10 / 0.2 ... 2.5 mm ²
Section for connection of currents	AWG 34 ... 10 / 0.2 ... 2.5 mm ²
Weight	14.11 oz / 400 g

DIRIS A-20

Multifunction power meter - Panel mounted
Works with 5A secondary current transformers

Plug-in optional modules

DIRIS A-20

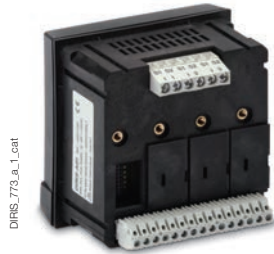

DIRIS_773_a_1_cat

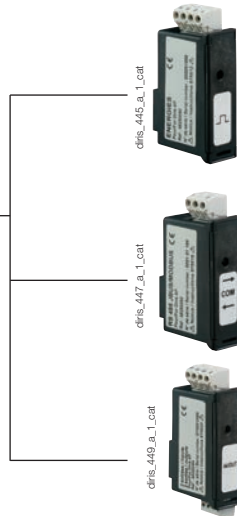

1 output

1 output that can be configured for:

- pulses: configurable (type, weight, duration) to kWh or kVarh.
- Monitoring: 3I, In, 3V, 3U, F, ΣP, ΣQ, ΣS, ΣPFL/C, THD 3I, THD 3V, THD 3U and timer meter.
- Equipment control

Communication

RS485 Modbus RTU communication (speed up to 38400 baud).

3 inputs , 1 output

3 inputs can be configured into:

- Information report from an external contact.

1 output that can be configured for:

- Pulses: configurable (type, weight, duration) to kWh or kVarh.
- Monitoring: 3I, In, 3V, 3U, F, ΣP, ΣQ, ΣS, ΣPFL/C, THD 3I, THD 3V, THD 3U and timer meter.
- Equipment control

Electrical characteristics

Current measurement (TRMS)	
Via CT primary	9 999 A
Via CT secondary	5 A
Measurement range	0 ... 11 kA
Input consumption	0.6 VA
Measurement updating period	1 s
Accuracy	0.2%
Permanent overload	6 A
Intermittent overload	10 I _n over 1 sec
Voltage measurements (TRMS)	
Direct measurement between phases	50 ... 500 VAC
Direct measurement between phase and neutral	28 ... 289 VAC
Input consumption	≤ 0.1 VA
Measurement updating period	1 s
Accuracy	0.2%
Power measurement	
Measurement updating period	1 s
Accuracy	0.5%
Power factor measurement	
Measurement updating period	1 s
Accuracy	0.5%
Frequency measurement	
Measurement range	45 ... 65 Hz
Measurement updating period	1 s
Accuracy	0.1%

Energy accuracy	
Active (according to IEC 62053-22)	Class 0.5 S
Reactive (according to IEC 62053-23)	Class 2
Auxiliary power supply	
Alternative voltage	110 ... 400 VAC
AC tolerance	± 10%
DC voltage	120 ... 289 VDC
DC tolerance	± 20%
Frequency	50 / 60 Hz
Power consumption	10 VA
Pulse or alarm output	
Number	1
Type	100 VDC - 0.5 A - 10 VA
Max. number of manoeuvres	≤ 10 ⁹
Inputs	
Number	3
Power supply	10 ... 30 VDC
Minimum width of signal	10 ms
Minimum length between 2 pulses	18 ms
Type	Optical couplers
Communication	
Link	RS485
Type	2 to 3 half duplex wires
Protocol	MODBUS® in RTU mode
MODBUS® speed	1400 ... 38400 baud
Operating conditions	
Operating temperature range	+14 ... +131 °F / - 10 ... + 55 °C
Storage temperature	-4 ... +158 °F / - 20 ... + 70 °C
Relative humidity	95%

References

Power Meter		Reference	
DIRIS A-20		4825 0402	
Optional plug-in modules		Reference	
1 digital output		4825 0080	
RS485 Modbus RTU communication		4825 0082	
3 digital inputs / 1 digital output		4825 0083	
Accessories		To be ordered in multiples of	Reference
3-pole RM Class CC fuse holder to protect voltage inputs		4	5705 0003
2-pole RM Class CC fuse holder to protect power supply input		6	5701 0002
Commissioning		Reference	
1/2 day remote commissioning	Remote commissioning including installation verification, programming and communication testing	9230100027	
1/2 day on-site commissioning	On-site commissioning including installation verification, programming and communication testing	9230100004	

Expert Services

Our service engineers are an essential part of our team, and they are dedicated to ensuring your power monitoring system provides accurate and reliable measurements to your EPMS software or SCADA system. Our services include:

- > Site audits to verify the proper wiring of your system
- > Personnel training on how to configure, operate and maintain power monitoring equipment and associated software
- > Remote and on-site commissioning to ensure that your system is up and running quickly, with peace of mind.

For further information, please contact your nearest SOCOMEC branch.



DIRIS A-10

Multifunction power meter - DIN-rail mounted
Works with 5A secondary current transformers



DIRIS A-10

Function

The **DIRIS A-10** is a DIN-rail mounted power meter.

Advantages

Easy to use

Backlit LCD display with 5 hotkeys for direct access to measurement and configuration menus.

Built-in temperature sensor

It allows variations in temperature to be detected.

Compliant with ANSI C12.20 and IEC 61557-12

ANSI C12.20 and IEC 61557-12 are high-level standards for power metering & monitoring devices. Compliance with these standards ensures equipment performance and reliability in terms of accuracy, as well as mechanical, EMC, temperature etc.

Bi-Directional Metering

DIRIS A-10 can measure the flow of electricity in both directions (import / export).

Principle diagram

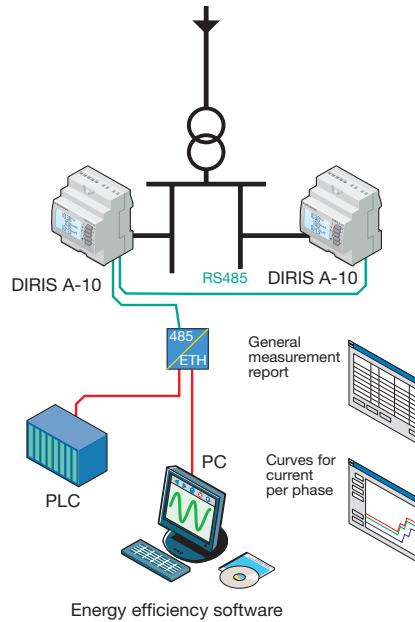

The solution for

- > Industry
- > Infrastructures
- > Building



Strong points

- > Easy to use
- > Integrated temperature sensor
- > Detects wiring errors
- > Compliant with ANSI C12.20 and IEC 61557-12

Conformity to standards

- > UL 61010-1
CSA-C22.2 No. 61010-1
Guide PICQ
File E257746



- > ANSI C12.20



- > IEC 61557-12

- > CEC compliant



Functions

Multi-measurement

- Currents
 - instantaneous: I1, I2, I3, In
 - maximum average: I1, I2, I3, In
- Voltages & frequency
 - instantaneous: V1, V2, V3, U12, U23, U31, F
- Power
 - instantaneous: 3P, ΣP, 3Q, ΣQ, 3S, ΣS
 - maximum average: ΣP, ΣQ, ΣS
- Power factors
 - instantaneous: 3PF, ΣPF

Metering

- Active energy: +/- kWh
- Reactive energy: +/- kVarh
- Hour Meter: ⌚

Harmonic analysis

- Total harmonic distortion (level 51)
 - Currents: thd I1, thd I2, thd I3
 - Phase-to-neutral voltage: thd V1, thd V2, thd V3
 - Phase-to-phase voltage: thd U12, thd U23, thd U31

Dual tariff function

Selection of one out of 2 billing tariffs

Events

Alarms on all electrical values

Communications

RS485 with MODBUS protocol

Input

- Tariff selection
- Remote device status

Output

- Remote command of device
- Alarm report
- Pulse report

Front panel

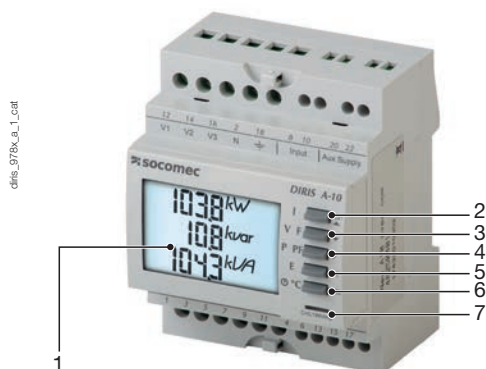

1. Backlit LCD display.
2. Direct access key for currents (instant and maximum), current THD and test function.
3. Direct access key for voltages, frequency and voltage THD.
4. Direct access key for active, reactive and apparent power (instantaneous and max. values) and power factor.
5. Direct access key for energies.
6. Pushbutton for hour meter, temperature and programming menu access.
7. Metrological LED.

Dimensions (in/mm)

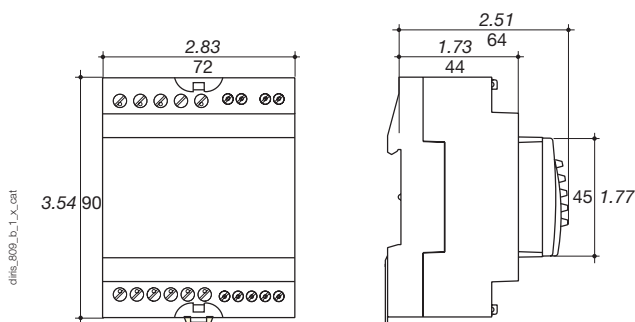

Type	Modular
Number of modules	4
Dimensions W x H x D	2.83 x 3.54 x 2.51 in / 72 x 90 x 64 mm
Case degree of protection	IP 30
Front degree of protection	IP 52
Display type	Backlit LCD display
Voltage and current connection cross-section	AWG 6 / 4 mm ²
Connection cross-section for AUX supply, input, output and comms.	AWG 10 / 2.5 mm ²
Weight	7.23 oz / 205 g (4825 0400) 7.58 oz / 215 g (4825 0401)

DIRIS A-10

Multifunction power meter - DIN-rail mounted
Works with 5A secondary current transformers

Electrical characteristics

Current measurement (TRMS)	
Via CT primary	9 999 A
Via CT secondary	5 A
Measurement range	0 ... 11 kA
Input consumption	0.6 VA
Measurement updating period	1 s
Accuracy	0.2 %
Permanent overload	6 A
Intermittent overload	10 I _n for 1 s
Voltage measurements (TRMS)	
Direct measurement between phases	50 ... 500 VAC
Direct measurement between phase and neutral	28 ... 289 VAC
Input consumption	≤ 0.1 VA
Measurement updating period	1 s
Accuracy	0.2 %
Power measurement	
Measurement updating period	1 s
Accuracy	0.5 %
Power factor measurement	
Measurement updating period	1 s
Accuracy	0.5 %
Frequency measurement	
Measurement range	45 ... 65 Hz
Measurement updating period	1 s
Accuracy	0.1 %

Energy accuracy	
Active (according to IEC 62053-22)	Class 0.5 S
Reactive (according to IEC 62053-23)	Class 2
Auxiliary power supply	
Alternating voltage	110 ... 277 VAC
AC tolerance	± 15 %
Frequency	50 / 60 Hz
Consumption	< 3 VA
Digital output (pulses or on/off)	
Number	1
Type	20 / 30 VDC - 0.5 A - 10 VA
Max. number of operations	≤ 10 ⁸
Input (tariff)	
Number	1
Type	0 VAC: T1 / 200-277 VAC: T2
Communication	
Link	RS485
Type	2 ... 3 half duplex wires
Protocol	MODBUS RTU
MODBUS® speed	2400 ... 38400 bauds
Operating conditions	
Operating temperature	+14 °F ... +131 °F / - 10 ... + 55 °C
Storage temperature	-4 °F ... +158 °F / - 20 ... + 70 °C
Relative humidity	85 %

References

DIRIS A power meters		Reference
DIRIS A-10	Pulse output only	4825 0400
DIRIS A-10	Pulse output + RS485 Modbus RTU communication	4825 0401

Accessories	Sold in multiples of	Reference
3-pole RM Class CC fuse holder to protect voltage inputs	4	5705 0003
2-pole RM Class CC fuse holder to protect power supply input	6	5701 0002

Commissioning		Reference
1/2 day remote commissioning	Remote commissioning including installation verification, programming and communication testing	9230100027
1/2 day on-site commissioning	On-site commissioning including installation verification, programming and communication testing	9230100004

Expert Services

Our service engineers are an essential part of our team, and they are dedicated to ensuring your power monitoring system provides accurate and reliable measurements to your EPMS software or SCADA system.

Our services include:

- > Site audits to verify the proper wiring of your system
- > Personnel training on how to configure, operate and maintain power monitoring equipment and associated software
- > Remote and on-site commissioning to ensure that your system is up and running quickly, with peace of mind.

For further information, please contact your nearest SOCOMEC branch.



DIRIS DigiBOX A

Multifunction power meter - enclosed



DIRIS DigiBOX A
Enclosed power meter



Function

DIRIS DigiBOX A is an easy-to-install enclosed single-point submetering solution. It provides users with all they need for a complete submeter installation. Simply select the current sensors (CTs) from our wide plug and play selection to complete your system. With just two part numbers, DIRIS DigiBOX A allows you to address a wide range of metering applications.

DigiBOX A is powered by our DIRIS A-40 and DIRIS A-200 power monitoring device, loaded with features, design and performance.

Advantages

Easy to order

- Same part number for indoor or outdoor installations (NEMA 3R, 12, 4, 4X)
- Approved for indoor or outdoor installations (NEMA 3R, 12, 4, 4X)
- Universal system voltage and power supply
- DigiBOX A comes standard with flexible I/Os and communication protocols

Safe and Reliable

- cULus listed enclosures and components
- Assembled at our cULus 508A facility
- Fused voltage connections
- Detailed installation and commissioning instruction guides

Plug & Play design

- Color-coded RJ12 cables for easy phase identification when wiring current sensors to the DigiBOX A
- Automatic detection of current sensor type and rating
- Using low-voltage mV current sensors, no shunting blocks are needed, they can be disconnected safely under load

Accurate

Accuracy of measurements meets ANSI C12.20 and IEC 61557-12 standards:

- Class 0.5 system accuracy (Meter + TE/ITR/TF current sensors) from 2% to 120% of rated current
- Class 0.2 DigiBOX A meter accuracy

The solution for

- > Industry
- > Buildings
- > Infrastructure



Strong points

- > Easy to order
- > Plug & Play design
- > Accuracy
- > Safe and Reliable

Conformity to standards

- > cULus 508A
- > ANSI C12.20
- > PBI Meter per CA Energy Commission
- > IEC 61557-12



- > UL 61010-1
CSA-C22.2 No. 61010-1
Guide PICQ
File E257746



Create your project

- > Find the best power monitoring configuration:
www.meter-selector.com



Selection Guide

DigiBOX A		
		
	DIRIS A-40	DIRIS A-200
Metering technology	DIRIS A-40	DIRIS A-200
Number of metering points (3P)	1	1
Number of current inputs	3	4
Display	•	•
WEBVIEW webservice	•	•
Communication		
RS485 ⁽¹⁾	•	•
Ethernet ⁽²⁾	•	•
Enclosure		
Type	Polycarbonate	Polycarbonate
Rating	NEMA 4X	NEMA 4X
Dimensions (H x W x D)	12 x 10 x 6 in	12 x 10 x 6 in
Electrical characteristics		
Voltage Input	110 - 277 VAC	110 - 600 VAC
Energy metering		
±kWh, ±kvarh, kVAh	•	•
ΣP (kW), ΣQ (kvar), ΣS (kVA), PF	•	•
P (kW), Q (kvar), S (kVA), PF per phase	•	•
Multi-measurement		
Amps, Volts, Frequency	•	•
Unbalance U, V, I	•	•
Power quality		
THD U, V, I	•	•
Individual Harmonics V, U, I (up to 63rd)	•	•
PQ Events (sags, swells, interruptions and overcurrents)	•	•
Waveform capture	•	•
Alarms		
Measurement thresholds	•	•
System alarms	•	•
Email notifications	•	•
Reference	USDBPA40ET	USDBPA200RJ

(1) Supported RS485 protocol: Modbus RTU.

(2) Supported Ethernet protocols: ModbusTCP/IP, BACnet IP.

DIRIS DigiBOX A

Multifunction power meter - enclosed

Dimensions (in/mm)

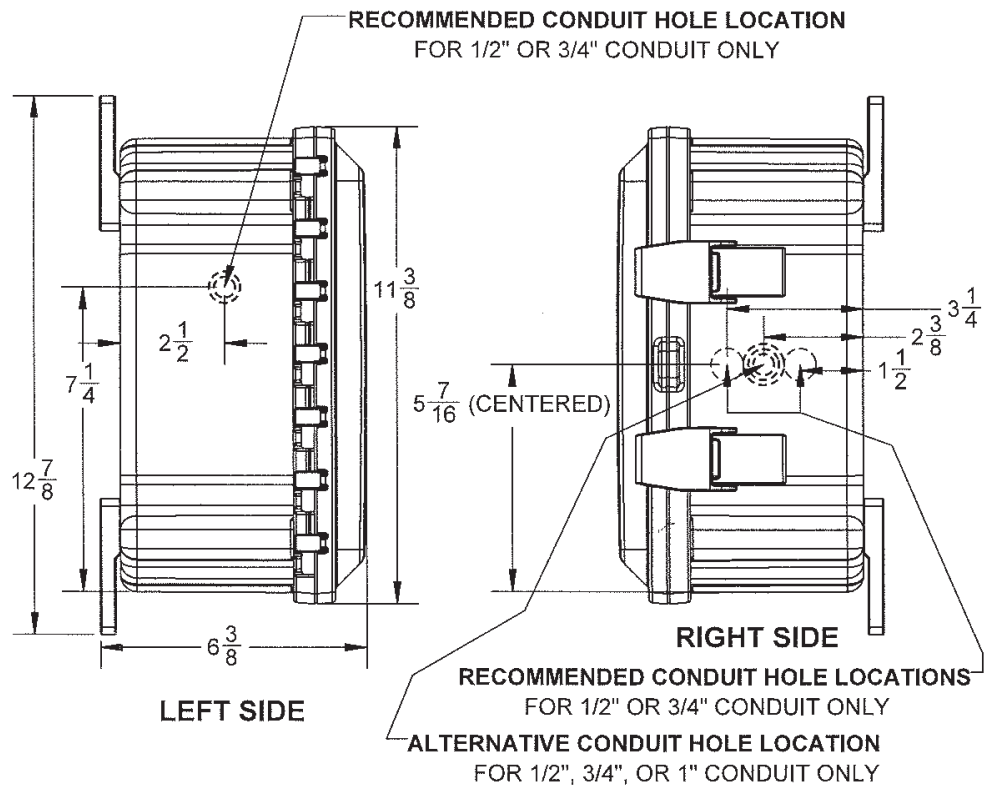
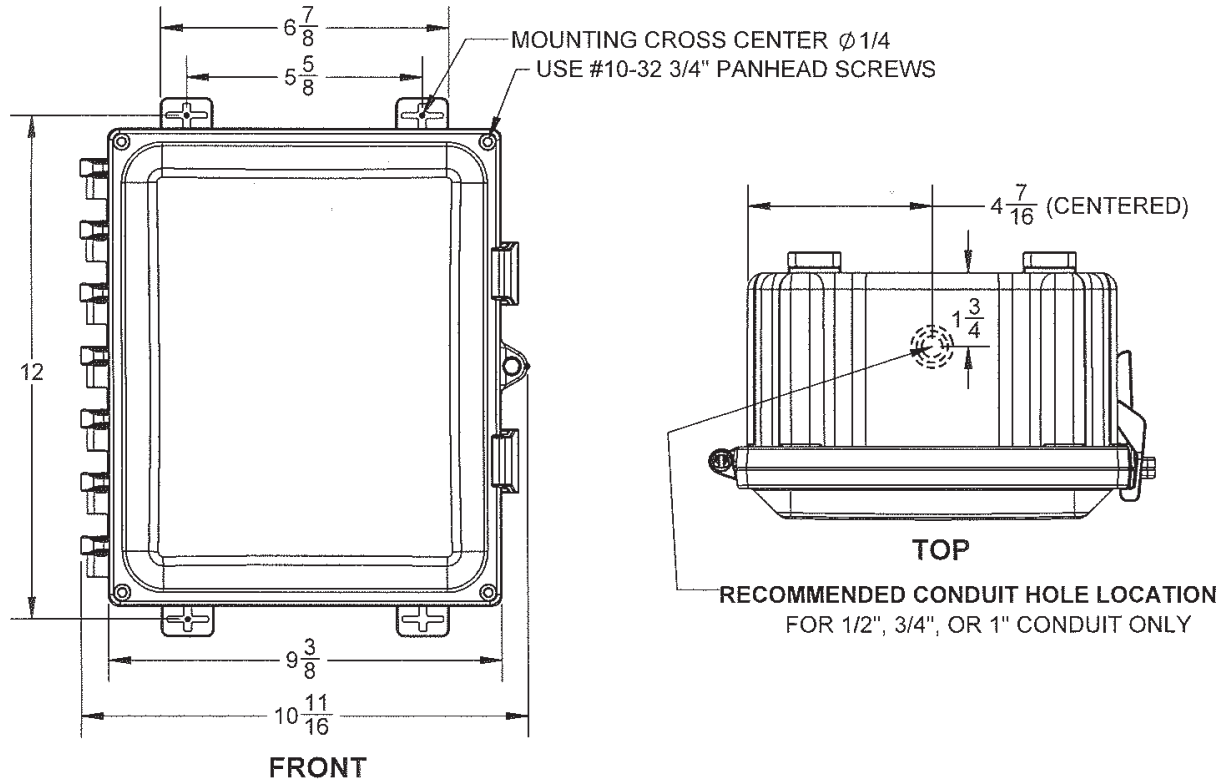

Technical Characteristics

Electrical characteristics

Input Power	
Voltage	<ul style="list-style-type: none"> • 110-277 VAC (Ph-Ph or Ph-N) with USBPA40ET • 110-600 VAC (Ph-Ph or Ph-N) with USBPA200RJ
Frequency	50/60 Hz

Measurement characteristics

Power and energy measurement	
Accuracy active energy and active power	Class 0.2, DigiBOX A (Meter only) Class 0.5 (Meter with TE, iTR, TF sensors) Class 1 (Meter + TR sensors)
Accuracy of reactive energy	Class 1 (Meter with TE, iTR, TF sensors)

Power factor measurement	
Accuracy	Class 0.5 (Meter with TE, iTR, TF sensors) Class 1 (Meter with TR sensors)

Voltage measurement	
Electrical network type	Single-phase (1P2W) / Two-phase (2P2W) / Two-phase with neutral (2P3W) / Three-phase (3P3W) / Three-phase with neutral (3P4W)
Voltage measurement rating	<ul style="list-style-type: none"> • 50-300 VAC L-N / 87-520 VAC (Ph-Ph) - CAT III with USBPA40ET • 50-600 VAC (Ph-N) / 90-690 VAC (Ph-Ph) - CAT III with USBPA200RJ
Voltage accuracy	Class 0.2 for DigiBOX A-40 and class 0.1 for DigiBOX A-200
Voltage input consumption	≤ 1 VA
Frequency range	45 – 65 Hz
Frequency accuracy	Class 0.02

Current measurement	
Number of current inputs	<ul style="list-style-type: none"> • 3 with USBPA40ET • 4 with USBPA200RJ
Associated current sensors	Solid-core TE, split-core TR/iTR, flexible TF current sensors
Connection	Socomec RJ12 cables
Accuracy	Class 0.2 DigiBOX A-40 only Class 0.1 DigiBOX A-200 only Class 0.5 (Meter with TE, iTR, TF sensors) Class 1 (Meter with TR sensors)

Mechanical characteristics

Application	Indoor or outdoor installations
Enclosure	Polycarbonate with UV inhibitors UL94-5VA flammability rating
Enclosure dimensions (in)	12 (H) x 10 (W) x 6 (D)
Protection rating	NEMA 4X / IP66
Operational temperature	<ul style="list-style-type: none"> • +14...+158°F/-10°C...+70°C with USBPA40ET • -13...+158°F/-25°C...+70°C with USBPA200RJ
Altitude	≤ 9840 ft / 3000 m

Communication characteristics

RS485	
Link	RS485
Connection Type	Half-Duplex, 2 wires
Protocol	Modbus RTU
Baudrate	9600 – 115200 baud

Ethernet	
Link	Ethernet
Connection Type	RJ45 10/100 Mbs
Protocol	Modbus TCP/IP, BACnet IP

USB	
Link	Micro USB Type b
Protocol	Modbus RTU
Use	Use Configuration via Easy Config System and firmware upgrade via Product Upgrade Tool

DIRIS DigiBOX A

Multifunction power meter - enclosed

References

DIRIS DigiBOX A enclosed power meters		Reference
DigiBOX A-40	RS485 Modbus RTU + Ethernet Modbus TCP & BACnet IP - 110 - 277 VAC L-N	USDBPA40ET
DigiBOX A-200	RS485 Modbus RTU + Ethernet Modbus TCP & BACnet IP - 110 - 600 VAC L-N	USDBPA200RJ

Accessories	Reference
1A/5A secondary CT adapter with RJ12 output	4829 0599
6.5-ft USB Cable for configuration - Type A to Type Micro-B	4829 0050

RJ12 Solid-core current sensors ⁽¹⁾				
Model	Nominal current range (A)	Real range covered (A)	Window size (in/mm)	Reference
TE-18	5 ... 20	0.1 ... 24	∅ 0.33 / 8.6	4829 0500
TE-18	25 ... 63	0.5 ... 75	∅ 0.33 / 8.6	4829 0501
TE-25	40 ... 160	0.8 ... 192	0.53 x 0.53 / 13.5 x 13.5	4829 0502
TE-35	63 ... 250	1.26 ... 300	0.82 x 0.82 / 21 x 21	4829 0503
TE-45	160 ... 630	3.2 ... 756	1.22 x 1.22 / 31 x 31	4829 0504
TE-55	400 ... 1000	8 ... 1200	1.61 x 1.61 / 41 x 41	4829 0505
TE-90	600 ... 2000	12 ... 2400	2.52 x 2.52 / 64 x 64	4829 0506

(1) Refer to pages 348-351 for more information on TE current sensors

RJ12 Split-core current sensors ⁽²⁾				
Model	Nominal current range (A)	Real range covered (A)	Window size (in/mm)	Reference
TR-10 / iTR-10	25 ... 63	0.5 ... 75.6	∅ 0.39 / 10	4829 0555 / 4829 0655
TR-14 / iTR-14	40 ... 160	0.8 ... 192	∅ 0.55 / 14	4829 0556 / 4829 0656
TR-21 / iTR-21	63 ... 250	1.26 ... 300	∅ 0.83 / 21	4829 0557 / 4829 0657
TR-32 / iTR-32	160 ... 600	3.2 ... 720	∅ 1.26 / 32	4829 0558 / 4829 0658

(2) Refer to pages 352-353 for more information on TR/iTR current sensors

RJ12 Flexible Rogowski current sensors ^{(3) (4)}				
Model	Nominal current range (A)	Real range covered (A)	Window size (in/mm)	Reference
TF-40	100 ... 400	2 ... 480	∅ 1.57 / 40	4829 0573
TF-80	150 ... 600	3 ... 720	∅ 3.15 / 80	4829 0574
TF-120	400 ... 2000	8 ... 2400	∅ 4.72 / 120	4829 0575
TF-200	600 ... 4000	12 ... 4800	∅ 7.87 / 200	4829 0576
TF-300	1600 ... 6000	32 ... 7200	∅ 11.81 / 300	4829 0577
TF-600	1600 ... 6000	32 ... 7200	∅ 23.62 / 600	4829 0578
Set of 3 RJ12 female/female connectors for RJ12 lead extension between power meter and TF sensor				4829 0670

(3) TF Rogowski sensors come with a 6-ft cable lead with RJ12 male connector

(4) Refer to pages 354-355 for more information on TF current sensors

RJ12 sensor lead cables	Cable length (ft / m)										
	0.32/0.1	0.64/0.2	0.96/0.3	1.64/0.5	3.3/1	6.5/2	9.84/3	16.4/5	22.9/7	32.8/10	164/50 reel + 100 connectors
Number of cables	Reference	Reference	Reference	Reference	Reference	Reference	Reference	Reference	Reference	Reference	Reference
1	-	-	-	-	-	-	-	4829 0602	-	4829 0603	4829 0601
3	4829 0580	4829 0581	4829 0582	4829 0595	4829 0583	4829 0584	4829 0606	4829 0607	4829 0608	4829 0609	-
4	-	-	-	4829 0596	4829 0588	4829 0589	-	-	-	-	-
6	4829 0590	4829 0591	4829 0592	4829 0597	4829 0593	4829 0594	-	-	-	-	-

Commissioning		Reference
1/2 day remote commissioning	Remote commissioning including installation verification, programming and communication testing	9230100027
1/2 day on-site commissioning	On-site commissioning including installation verification, programming and communication testing	9230100004

Expert Services

Our service engineers are an essential part of our team, and they are dedicated to ensuring your power monitoring system provides accurate and reliable measurements to your EPMS software or SCADA system.

Our services include:

- > Site audits to verify the proper wiring of your system
- > Personnel training on how to configure, operate and maintain power monitoring equipment and associated software
- > Remote and on-site commissioning to ensure that your system is up and running quickly, with peace of mind.

For further information, please contact your nearest SOCOMEC branch.



DIRIS DigiBOX B

Multifunction power meter - enclosed



DIRIS DigiBOX B
Enclosed power meter



Function

DIRIS DigiBOX B is an easy-to-install enclosed single-point submetering solution. It provides users with all they need for a complete submeter installation. Simply select the current sensors (CTs) from our wide plug & play selection to complete your system. With just two part numbers, DIRIS DigiBOX B allows you to address a wide range of metering applications.

DigiBOX B is powered by our DIRIS B-30 power monitoring device that communicates Modbus RTU via RS485.

Advantages

Safe and reliable

- cULus listed enclosures and components
- Assembled at our cULus 508A facility
- Fused voltage connections
- Detailed installation and commissioning instruction guides

Accurate

Accuracy of measurements meets ANSI C12.20 and IEC 61557-12 standards:

- Class 0.5 system accuracy (Meter + TE/ITR/TF current sensors) from 2% to 120% of rated current
- Class 0.2 DigiBOX B meter accuracy

Plug & Play design

- Color coded RJ12 cables for easy phase identification when wiring current sensors to the DigiBOX B
- Automatic detection of current sensor type and rating
- Using low-voltage mV current sensors, no shorting blocks are needed, they can be disconnected safely under load

The solution for

- > Renewable
- > Infrastructure
- > Industry
- > Buildings



Strong points

- > Safe and reliable
- > Plug & Play design
- > Accurate

Conformity to standards

- > cULus 508A



- > ANSI C12.20

- > PBI Meter per CA Energy Commission



- > IEC 61557-12

- > UL 61010-1
CSA-C22.2 No. 61010-1
Guide PICQ



Selection Guide

	DigiBOX B
	
Metering technology	DIRIS B-30
Number of metering points (3P)	1
Number of current inputs	4
Communication	
RS485 (*)	•
Enclosure	
Type	Polycarbonate
Rating	NEMA 4X
Dimensions (H x W x D)	12 x 10 x 6 in
Electrical characteristics	
Voltage Input	110 - 240 VAC
Energy metering	
±kWh, ±kvarh, kWh	•
ΣP (kW), ΣQ (kvar), ΣS (kVA), PF	•
P (kw), Q (kVAR), S (kVA), PF per phase	•
Multi-measurement	
Amps, Volts, Frequency	•
Unbalance U, V, I	•
Power quality	
THD U, V, I	•
Individual Harmonics V, U, I (up to 63rd)	•
PQ Events (sags, swells, interruptions and overcurrents)	•
Alarms	
Measurement thresholds	•
System alarms	•
Reference	USDBBB30NDO

(*) Supported RS485 protocol: Modbus RTU

DIRIS DigiBOX B

Multifunction power meter - enclosed

Dimensions (in/mm)

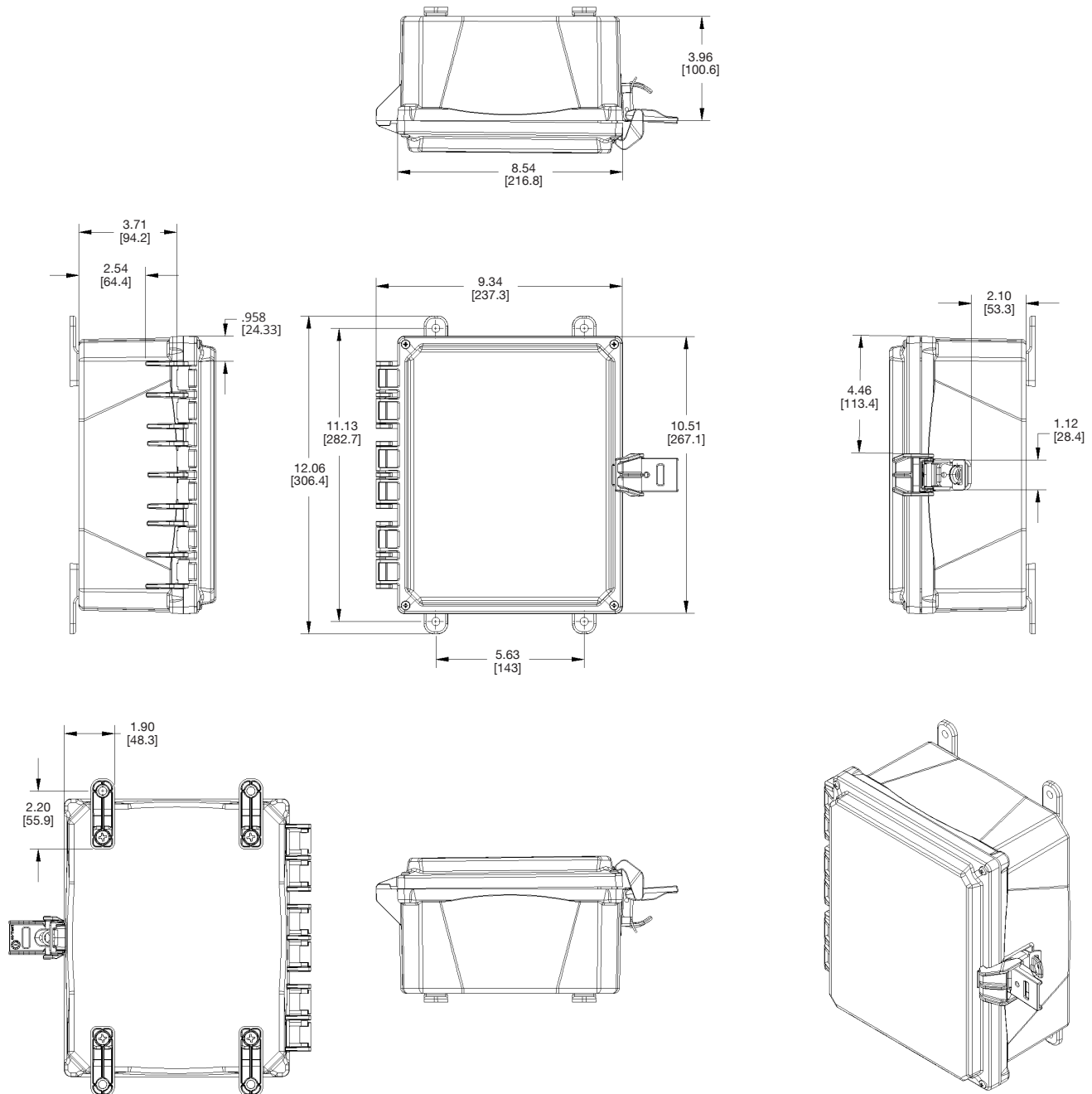

Technical characteristics

Electrical characteristics

Input Power	
Voltage	110 - 240 VAC (Ph-Ph or Ph-N) with USDBBB30NDO 110 - 480 VAC (Ph-Ph or Ph-N) with USDBPB30NDO
Frequency	50/60 Hz

Measurement characteristics

Power and energy measurement	
Accuracy active energy and active power	Class 0.2, DigiBOX B (Meter Only) Class 0.5 (Meter with TE, iTR, TF sensors) Class 1 (Meter + TR sensors)
Accuracy reactive energy	Class 2 (Meter with TE, iTR, TF sensors)
Power factor measurement	
Accuracy	Class 0.5 (Meter with TE, iTR, TF sensors) Class 1 (Meter + TR sensors)
Voltage measurement	
Electrical network type	Single-phase (1P2W) / Two-phase (2P2W) / Two-phase with neutral (2P3W) / Three-phase (3P3W) / Three-phase with neutral (3P4W)
Voltage measurement rating	500-300 VAC (Ph-N) / 87-520 VAC (Ph-Ph) – CAT III
Voltage accuracy	Class 0.02
Voltage input consumption	≤ 1 VA
Frequency range	45 – 65 Hz
Frequency accuracy	Class 0.2
Current measurement	
Number of current inputs	4
Associated current sensors	Solid-core TE, split-core TR/iTR, flexible Rogowski TF
Connection	Socomec RJ12 cables
Accuracy	Class 0.2 DigiBOX B (Meter Only) Class 0.5 (Meter with TE, iTR, TF sensors) Class 1 (Meter + TR sensors)

Mechanical characteristics

Enclosure	Polycarbonate
Enclosure dimensions (in)	12 (H) x 10 (W) x 6 (D)
Protection rating	NEMA 4X / IP66
Operational temperature	+14 ... +158 °F / -10 °C ... +70 °C
Altitude	≤ 9840 ft / 3000 m
RS485	
Link	RS485
Connection type	Half-Duplex, 2 wires
Protocol	Modbus RTU
Baudrate	1200 – 115200 baud
USB	
Link	Micro USB Type b
Protocol	Modbus RTU
Use	Configuration via Easy Config System and firmware upgrade via Product Upgrade Tool

DIRIS DigiBOX B

Multifunction power meter - enclosed

References

DIRIS DigiBOX B enclosed power meters		Reference
DigiBOX B-30	RS485 Modbus RTU - 110 - 240 VAC	USDBBB30NDO
DigiBOX B-30	RS485 Modbus RTU - 110 - 480 VAC	USDBPB30NDO

Accessories		Reference
1A/5A secondary CT adapter with RJ12 output		4829 0599
6.5-ft USB Cable for configuration - Type A to Type Micro-B		4829 0050

RJ12 Solid-core current sensors ⁽¹⁾				
Model	Nominal current range (A)	Real range covered (A)	Window size (in/mm)	Reference
TE-18	5 ... 20	0.1 ... 24	∅ 0.33 / 8.6	4829 0500
TE-18	25 ... 63	0.5 ... 75	∅ 0.33 / 8.6	4829 0501
TE-25	40 ... 160	0.8 ... 192	0.53 x 0.53 / 13.5 x 13.5	4829 0502
TE-35	63 ... 250	1.26 ... 300	0.82 x 0.82 / 21 x 21	4829 0503
TE-45	160 ... 630	3.2 ... 756	1.22 x 1.22 / 31 x 31	4829 0504
TE-55	400 ... 1000	8 ... 1200	1.61 x 1.61 / 41 x 41	4829 0505
TE-90	600 ... 2000	12 ... 2400	2.52 x 2.52 / 64 x 64	4829 0506

(1) Refer to pages 348-351 for more information on TE current sensors

RJ12 Split-core current sensors ⁽²⁾				
Model	Nominal current range (A)	Real range covered (A)	Window size (in/mm)	Reference
TR-10 / iTR-10	25 ... 63	0.5 ... 75.6	∅ 0.39 / 10	4829 0555 / 4829 0655
TR-14 / iTR-14	40 ... 160	0.8 ... 192	∅ 0.55 / 14	4829 0556 / 4829 0656
TR-21 / iTR-21	63 ... 250	1.26 ... 300	∅ 0.83 / 21	4829 0557 / 4829 0657
TR-32 / iTR-32	160 ... 600	3.2 ... 720	∅ 1.26 / 32	4829 0558 / 4829 0658

(2) Refer to pages 352-353 for more information on TR/iTR current sensors

RJ12 Flexible Rogowski current sensors ^{(3) (4)}				
Model	Nominal current range (A)	Real range covered (A)	Window size (in/mm)	Reference
TF-40	100 ... 400	2 ... 480	∅ 1.57 / 40	4829 0573
TF-80	150 ... 600	3 ... 720	∅ 3.15 / 80	4829 0574
TF-120	400 ... 2000	8 ... 2400	∅ 4.72 / 120	4829 0575
TF-200	600 ... 4000	12 ... 4800	∅ 7.87 / 200	4829 0576
TF-300	1600 ... 6000	32 ... 7200	∅ 11.81 / 300	4829 0577
TF-600	1600 ... 6000	32 ... 7200	∅ 23.62 / 600	4829 0578
Set of 3 RJ12 female/female connectors for RJ12 lead extension between power meter and TF sensor				4829 0670

(3) TF Rogowski sensors come with a 6-ft cable lead with RJ12 male connector

(4) Refer to pages 354-355 for more information on TF current sensors

RJ12 sensor lead cables	Cable length (ft / m)										
	0.32/0.1	0.64/0.2	0.96/0.3	1.64/0.5	3.3/1	6.5/2	9.84/3	16.4/5	22.9/7	32.8/10	164/50 reel + 100 connectors
Number of cables	Reference	Reference	Reference	Reference	Reference	Reference	Reference	Reference	Reference	Reference	Reference
1	-	-	-	-	-	-	-	4829 0602	-	4829 0603	4829 0601
3	4829 0580	4829 0581	4829 0582	4829 0595	4829 0583	4829 0584	4829 0606	4829 0607	4829 0608	4829 0609	-
4	-	-	-	4829 0596	4829 0588	4829 0589	-	-	-	-	-
6	4829 0590	4829 0591	4829 0592	4829 0597	4829 0593	4829 0594	-	-	-	-	-

Commissioning		Reference
1/2 day remote commissioning	Remote commissioning including installation verification, programming and communication testing	9230100027
1/2 day on-site commissioning	On-site commissioning including installation verification, programming and communication testing	9230100004

Expert Services

Our service engineers are an essential part of our team, and they are dedicated to ensuring your power monitoring system provides accurate and reliable measurements to your EPMS software or SCADA system.

Our services include:

- > Site audits to verify the proper wiring of your system
- > Personnel training on how to configure, operate and maintain power monitoring equipment and associated software
- > Remote and on-site commissioning to ensure that your system is up and running quickly, with peace of mind.

For further information, please contact your nearest SOCOMEC branch.



DIRIS DigiBOX M

Multi-circuit power meter - enclosed



DIRIS DigiBOX M8
Multi-point power meter



Function

Socomec's enclosed **DIRIS DigiBOX M** submetering line is designed to offer a complete and modular multi-circuit metering solution in NEMA 12/3R enclosures for indoor and outdoor use.

With ease of installation for retrofit applications and factory pre-wired Plug & Play technology, DIRIS DigiBOX solutions provide considerable savings in installation costs and customer site downtime. The solution offers the benefits of the scalable & customizable Digiware technology.

Advantages

Plug & Play

- Factory pre-wired
- Color-coded RJ12 cables for easy phase identification when wiring current sensors to the DigiBOX meters.
- Automatic detection of current sensor types and ratings
- Using low-voltage mV current sensors, no shunting blocks are needed, they can be disconnected safely under load

Accurate

Accuracy of measurements meets ANSI C12.20 and IEC 61557-12 standards:

- Class 0.5 system accuracy (Meter + TE / ITR / TF current sensors) from 2% to 120% of rated current
- Class 0.2 DigiBOX M meter accuracy

Safe & reliable

- Durable NEMA 12, 3R
- cULus listed enclosures and components
- Assembled at our cULus 508A facility
- Fused voltage connections
- Detailed installation and commissioning instruction guides

The solution for

- > Industry
- > Building
- > Infrastructure
- > Data center



The solution for

- > Plug & Play
- > Accurate
- > Safe & reliable

Conformity to standards

- > cULus 508A
- > IEC 61557-12
- > UL 61010-1
CSA-C22.22 No. 61010-1
Guide PICQ
File E257746



Create your project

- > Find the best power monitoring configuration:
www.meter-selector.com



Selection Guide

	<i>DigiBOX M4</i>		<i>DigiBOX M8</i>		<i>DigiBOX M4 Pro</i>				
									
Metering technology	DIRIS Digiware system		DIRIS Digiware system		DIRIS Digiware system		DIRIS Digiware system		
Number of metering points (3P)	4		8		4		8		
Number of current inputs	12		24		12		24		
Display		•		•		•		•	
WEBVIEW web interface						•		•	
Communication									
RS485 (*)	•	•	•	•	•	•	•	•	•
Ethernet (**)		•		•		•		•	•
Enclosure									
Type	Steel	Steel	Steel	Steel	Steel	Steel	Steel	Steel	Steel
Rating	NEMA 12/3R	NEMA 12/3R	NEMA 12/3R	NEMA 12/3R	NEMA 12/3R	NEMA 12/3R	NEMA 12/3R	NEMA 12/3R	NEMA 12/3R
Dimensions (H x W x D)	12 x 12 x 6 in	12 x 12 x 6 in	12 x 12 x 6 in	12 x 12 x 6 in	12 x 12 x 6 in	12 x 12 x 6 in	12 x 12 x 6 in	12 x 12 x 6 in	12 x 12 x 6 in
Electrical characteristics									
Voltage Input	200 - 480 VAC	200 - 480 VAC	200 - 480 VAC	200 - 480 VAC	200 - 480 VAC	200 - 480 VAC	200 - 480 VAC	200 - 480 VAC	200 - 480 VAC
Energy metering									
kWh (+/-), kvarh (+/-), kVAh	•	•	•	•	•	•	•	•	•
ΣP (kW), ΣQ (kvar), ΣS (kVA), PF	•	•	•	•	•	•	•	•	•
P (kW), Q (kvar), S (kVA), PF per phase	•	•	•	•	•	•	•	•	•
Multi-measurement									
Amps, Volts, Frequency	•	•	•	•	•	•	•	•	•
Unbalance U, V, I					•	•	•	•	•
Power quality									
THD U, V, I					•	•	•	•	•
Individual Harmonics V, U, I (up to 63rd)					•	•	•	•	•
PQ Events (sags, swells, interruptions and overcurrents)					•	•	•	•	•
Alarms									
Measurement thresholds	Power / Energies	Power / Energies	Power / Energies	Power / Energies	•	•	•	•	•
System alarms	•	•	•	•	•	•	•	•	•
Email notifications						•			•
References	USDBB04ND0	USDBB04D50	USDBB08ND0	USDBB08D50	USDBP04ND0	USDBP04D70	USDBP08ND0	USDBP08D70	

(*) Supported RS485 protocol: Modbus RTU

(**) Supported Ethernet protocols: Modbus TCP/IP, BACnet IP, SNMP V1, V2, V3 & Traps

DIRIS DigiBOX M

Multi-circuit power meter - enclosed

Dimensions

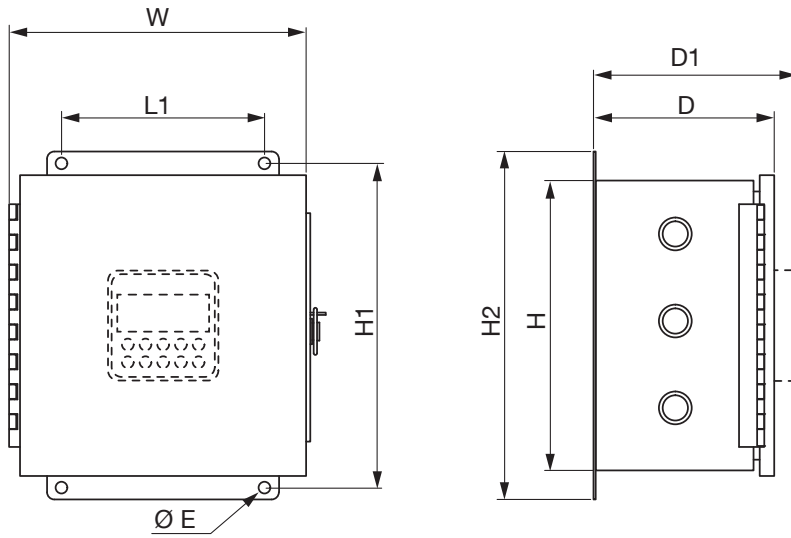

ccff-ul_048_a.ai

Technical Characteristics

Electrical characteristics	
Input Power	
Voltage	110-480 VAC
Frequency	50/60 Hz
Measurement characteristics	
Power and energy measurement	
Accuracy active energy and active power	Class 0.2, DigiBOX M alone Class 0.5 with TE, ITR, TF sensors Class 1 with TR sensors
Accuracy reactive energy	Class 1 with TE, ITR, TF sensors
Power factor measurement	
Accuracy	Class 0.5 with TE, ITR, TF sensors Class 1 with TR sensors
Voltage measurement	
Electrical network type	Single-phase (1P2W) / Two-phase (2P2W) / Two-phase with neutral (2P3W) / Three-phase (3P3W) / Three-phase with neutral (3P4W)
Voltage measurement rating	500-300 VAC (Ph-N) / 87-520 VAC (Ph-Ph) – CAT III
Voltage accuracy	Class 0.02
Voltage input consumption	≤ 1 VA
Frequency range	45 – 65 Hz
Frequency accuracy	Class 0.2
Current measurement	
Number of current inputs	DigiBOX M4: 12 DigiBOX M8: 24
Associated current sensors	Solid-core TE, split-core TR/ITR, flexible Rogowski TF
Connection	Dedicated Socomec RJ12 cables
Accuracy	Class 0.2 DigiBOX M alone
Mechanical characteristics	
Application	Indoor installations
Enclosure	Steel, finished in ANSI 61 gray powder coating
Enclosure dimensions (in)	12 (H) x 12 (W) x 6 (D)
Protection rating	NEMA 3R / IP24
Operational temperature	+14 ... +131 °F / -10 °C ... +70 °C
Altitude	≤ 9840 ft / 3000 m
Communication characteristics	
RS485	
Link	RS485
Connection Type	2 to 3 half duplex wires
Protocol	Modbus RTU
Baudrate	9600 – 115200 baud
Ethernet	
Link	Ethernet
Connection Type	RJ45 10/100 Mbs
Protocol	Modbus TCP/IP, BACnet IP, SNMP v1, v2, v3
USB	
Link	Micro USB Type b
Protocol	Modbus RTU
Use	Configuration via Easy Config System and firmware upgrade via Product Upgrade Tool

References

DIRIS DigiBOX M enclosed power meters		Reference
DIRIS DigiBOX M4 without display	12 current sensor inputs - RS485 Modbus RTU	USDBB04NDO
DIRIS DigiBOX M4 with display	12 current sensor inputs - RS485 Modbus RTU + Ethernet Modbus TCP + BACnet IP + SNMP	USDBB04D50
DIRIS DigiBOX M8 without display	24 current sensor inputs - RS485 Modbus RTU	USDBB08NDO
DIRIS DigiBOX M8 with display	24 current sensor inputs - RS485 Modbus RTU + Ethernet Modbus TCP + BACnet IP + SNMP	USDBB08D50
DIRIS DigiBOX M4 PRO without display	12 current sensor inputs - RS485 Modbus RTU - power quality and alarming	USDBP04NDO
DIRIS DigiBOX M4 PRO with display	12 current sensor inputs - RS485 Modbus RTU + Ethernet Modbus TCP + BACnet IP + SNMP - WEBVIEW-M webservice - power quality and alarming	USDBP04D70
DIRIS DigiBOX M8 PRO without display	24 current sensor inputs - RS485 Modbus RTU - power quality and alarming	USDBP08NDO
DIRIS DigiBOX M8 PRO with display	24 current sensor inputs - RS485 Modbus RTU + Ethernet Modbus TCP + BACnet IP + SNMP - WEBVIEW-M webservice - power quality and alarming	USDBP08D70

Accessories	Reference
1A/5A secondary CT adapter with RJ12 output	4829 0599
6.5-ft USB Cable for configuration - Type A to Type Micro-B	4829 0050

RJ12 Solid-core current sensors ⁽¹⁾				
Model	Nominal current range (A)	Real range covered (A)	Window size (in/mm)	Reference
TE-18	5 ... 20	0.1 ... 24	Ø 0.33 / 8.6	4829 0500
TE-18	25 ... 63	0.5 ... 75	Ø 0.33 / 8.6	4829 0501
TE-25	40 ... 160	0.8 ... 192	0.53 x 0.53 / 13.5 x 13.5	4829 0502
TE-35	63 ... 250	1.26 ... 300	0.82 x 0.82 / 21 x 21	4829 0503
TE-45	160 ... 630	3.2 ... 756	1.22 x 1.22 / 31 x 31	4829 0504
TE-55	400 ... 1000	8 ... 1200	1.61 x 1.61 / 41 x 41	4829 0505
TE-90	600 ... 2000	12 ... 2400	2.52 x 2.52 / 64 x 64	4829 0506

(1) Refer to pages 348-351 for more information on TE current sensors

RJ12 Split-core current sensors ⁽²⁾				
Model	Nominal current range (A)	Real range covered (A)	Window size (in/mm)	Reference
TR-10 / iTR-10	25 ... 63	0.5 ... 75.6	Ø 0.39 / 10	4829 0555 / 4829 0655
TR-14 / iTR-14	40 ... 160	0.8 ... 192	Ø 0.55 / 14	4829 0556 / 4829 0656
TR-21 / iTR-21	63 ... 250	1.26 ... 300	Ø 0.83 / 21	4829 0557 / 4829 0657
TR-32 / iTR-32	160 ... 600	3.2 ... 720	Ø 1.26 / 32	4829 0558 / 4829 0658

(2) Refer to pages 352-353 for more information on TR/iTR current sensors

RJ12 Flexible Rogowski current sensors ^{(3) (4)}				
Model	Nominal current range (A)	Real range covered (A)	Window size (in/mm)	Reference
TF-40	100 ... 400	2 ... 480	Ø 1.57 / 40	4829 0573
TF-80	150 ... 600	3 ... 720	Ø 3.15 / 80	4829 0574
TF-120	400 ... 2000	8 ... 2400	Ø 4.72 / 120	4829 0575
TF-200	600 ... 4000	12 ... 4800	Ø 7.87 / 200	4829 0576
TF-300	1600 ... 6000	32 ... 7200	Ø 11.81 / 300	4829 0577
TF-600	1600 ... 6000	32 ... 7200	Ø 23.62 / 600	4829 0578
Set of 3 RJ12 female/female connectors for RJ12 lead extension between power meter and TF sensor				4829 0670

(3) TF Rogowski sensors come with a 6-ft cable lead with RJ12 male connector

(4) Refer to pages 354-355 for more information on TF current sensors

RJ12 sensor lead cables	Cable length (ft / m)										
	0.32/0.1	0.64/0.2	0.96/0.3	1.64/0.5	3.3/1	6.5/2	9.84/3	16.4/5	22.9/7	32.8/10	164/50 reel + 100 connectors
Number of cables	Reference	Reference	Reference	Reference	Reference	Reference	Reference	Reference	Reference	Reference	Reference
1	-	-	-	-	-	-	-	4829 0602	-	4829 0603	4829 0601
3	4829 0580	4829 0581	4829 0582	4829 0595	4829 0583	4829 0584	4829 0606	4829 0607	4829 0608	4829 0609	-
4	-	-	-	4829 0596	4829 0588	4829 0589	-	-	-	-	-
6	4829 0590	4829 0591	4829 0592	4829 0597	4829 0593	4829 0594	-	-	-	-	-

References (continued)

RJ12 sensor lead cables	Cable length (ft / m)										164/50 reel + 100 connectors
	0.32/0.1	0.64/0.2	0.96/0.3	1.64/0.5	3.3/1	6.5/2	9.84/3	16.4/5	22.9/7	32.8/10	
Number of cables	Reference	Reference	Reference	Reference	Reference	Reference	Reference	Reference	Reference	Reference	Reference
1	-	-	-	-	-	-	-	4829 0602	-	4829 0603	4829 0601
3	4829 0580	4829 0581	4829 0582	4829 0595	4829 0583	4829 0584	4829 0606	4829 0607	4829 0608	4829 0609	-
4	-	-	-	4829 0596	4829 0588	4829 0589	-	-	-	-	-
6	4829 0590	4829 0591	4829 0592	4829 0597	4829 0593	4829 0594	-	-	-	-	-

Commissioning		Reference
1/2 day remote commissioning	Remote commissioning including installation verification, programming and communication testing	9230100027
1/2 day on-site commissioning	On-site commissioning including installation verification, programming and communication testing	9230100004

Expert Services

Our service engineers are an essential part of our team, and they are dedicated to ensuring your power monitoring system provides accurate and reliable measurements to your EPMS software or SCADA system.

Our services include:

- > Site audits to verify the proper wiring of your system
- > Personnel training on how to configure, operate and maintain power monitoring equipment and associated software
- > Remote and on-site commissioning to ensure that your system is up and running quickly, with peace of mind.

For further information, please contact your nearest SOCOMEC branch.



DIRIS MCM

Multi-circuit Energy & Power meter for retrofit & sub-metering applications



DIRIS MCM

Function

The DIRIS MCM is a revenue grade networked Energy & Power sub-meter promoting a simplified approach to retrofit applications, while ensuring safety and code compliance. It has been designed using industrial best practices providing industry leading durability and ease of installation.

The DIRIS MCM supports 333mV output or Rogowski style current sensors. It has been designed with mechanical, electrical and software features that will appeal to those seeking a simplified approach to installation and setup of energy management applications.

Advantages

Increased Safety

The DIRIS MCM is designed to improve installation safety and meets electrical code requirements:

- Built-in optional disconnect provides path to quickly and easily service the meter independently of other circuits.
- mV CT connections, can be connected and disconnected under load.
- No user-direct access to dangerous high voltages, keeping instrumentation engineers safe.
- Retained fasteners, ensuring screws stay securely in place and don't fall inside electrical panels.

Easy installation

- Wall or top cabinet mounting.
- Built-in 1" conduit holes - (3) at the bottom and (3) at the top of the meter.
- Push-in terminals for current sensors, no tools required!
- Clear visible numbering of CT inputs, with color coded terminals that match CT output lead wires.

Easy commissioning

- Configuration with a simple and intuitive PC application via a direct USB connection.
- One IP address and Modbus slave address supports the entire meter, simplifying network integration pain points.
- Patented CT configuration correction algorithm helps eliminate user wiring and setup errors while reducing downtime.

Industrial design

- Aluminum bonded enclosure.
- Internal fuse protection of each hot leg.
- Fuses can be replaced safely for maintenance.

Compact

- The most compact high density multi-circuit meter on the market, in an enclosed format.
- Ideal for retrofitting electrical distribution centers with limited wall space.

General Characteristics

- Accepts 333 mV and Rogowski sensors
- Modbus RTU, TCP and BACnet IP communication
- Wireless 915 MHz option
- Class 0.2 accuracy per ANSI C12.1

The solution for

- > Commercial buildings
- > Retail
- > Data centers
- > Industrial Buildings



Strong points

- > Increased safety
- > Easy installation
- > Easy commissioning
- > Industrial design
- > Compact

Compliance with standards

- > UL 61010-1
CSA-C22.22 No. 61010-1
Guide FTRZ/PICQ
File E257746



- > ANSI C12.1-2015 Class 0.2

- > IEC 62053-22



- > IEC 62053-23

Wireless Technology

RF system for wireless communication (915 MHz) of meter data.



RF END-Node
Transmitter



RF HUB-Node
Receiver

Typical Architecture

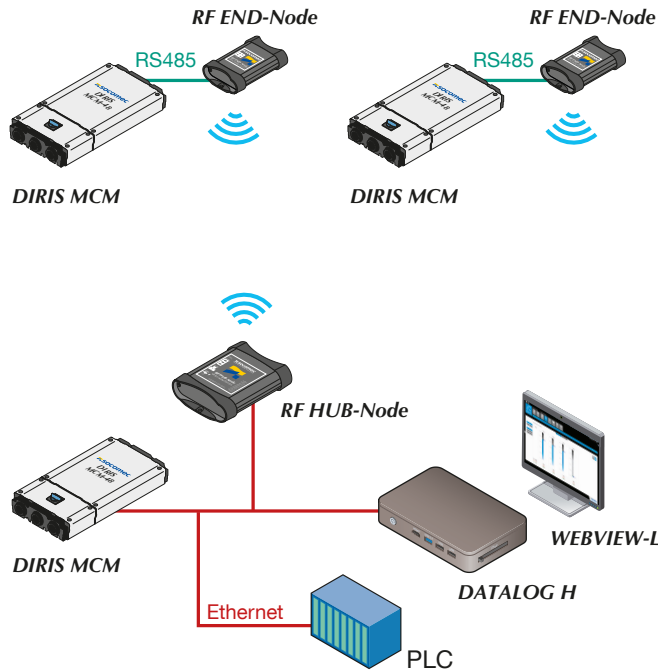

DIRIS MCM

DIRIS MCM power meters have been designed to be networked from different locations throughout a facility or campus environment. The DIRIS MCM supports Modbus protocol using either RS485 or Ethernet communication making compatibility and integration seamless with most EMS/BMS systems.

Need Wireless ?

For isolated metering points where it may be impractical or costly to bring a wired communication bus, the DIRIS MCM has been designed to be plug and play compatible with the RF system for wireless communication (915 MHz) of measurements.

The RF END-Node is connected via RS485 to the power meter (DIRIS MCM) and sends measurement via wireless link to the RF HUB-Node. No external power supply is required, as the END-Node is self-powered by the DIRIS MCM. Each HUB-Node can communicate wirelessly with up to (8) END-Nodes. The HUB-Node offers RS485 (Modbus RTU) and Ethernet (Modbus TCP) communication capabilities to any third-party EMS/BMS system.

WEBVIEW software

The DATALOG H80 provides data logging of measurements and the embedded web based application WEBVIEW-L allows to visualize real time and historical measurement data.

Current sensors

Various types of current sensors can be connected to the DIRIS MCM power meter. Socomec provides a range of split-core and Rogowski flexible sensors which make installation easy with minimum intrusion in retrofit applications. Our split-core sensors allow to measure up to 600 A, while our Rogowski sensors are ideal for busbar or high current applications up to 4000 A. Refer to page 4 for references, ratings and window sizes of current sensors.









TR-W Split-core
63-600 A

ROG Rogowski
Ip to 4000 A



Selection Guide

							
DIRIS MCM	MCM-16-N-N	MCM-16-D-N	MCM-16-D-D	MCM-48-N-N	MCM-48-N-D	MCM-48-D-N	MCM-48-D-D
General							
Number of current sensor inputs	16	16	16	48	48	48	48
Type of current sensors	333 mV 131 mV Rogowski	333 mV 131 mV Rogowski	333 mV 131 mV Rogowski	333 mV 131 mV Rogowski	333 mV 131 mV Rogowski	333 mV 131 mV Rogowski	333 mV 131 mV Rogowski
Disconnect Switch			•		•		•
Display		•	•			•	•
Communication							
RS485	Modbus RTU	Modbus RTU	Modbus RTU	Modbus RTU	Modbus RTU	Modbus RTU	Modbus RTU
Ethernet	Modbus TCP BACnet IP	Modbus TCP BACnet IP	Modbus TCP BACnet IP	Modbus TCP BACnet IP	Modbus TCP BACnet IP	Modbus TCP BACnet IP	Modbus TCP BACnet IP
Wireless	•	•	•	•	•	•	•
Electrical							
Number of voltage inputs	2	2	2	2	2	2	2
Energy metering							
±kWh, ±kvarh, kVAh	•	•	•	•	•	•	•
ΣP (kW), ΣQ (kvar), ΣS (kVA), ΣPF	•	•	•	•	•	•	•
P (kW), Q (kvar), S (kVA), PF per phase	•	•	•	•	•	•	•
Demand & Peak Demand	•	•	•	•	•	•	•
Multi - measurement							
U12, U23, U31, V1, V2, V3, f	•	•	•	•	•	•	•
U system, V system	•	•	•	•	•	•	•
I1, I2, I3, In	•	•	•	•	•	•	•
I system	•	•	•	•	•	•	•
Power quality							
THD U, V, I	•	•	•	•	•	•	•
Reference	4827 16NN	4827 16DN	4827 16DD	4827 0548	4827 0549	4827 48DN	4827 48DD

Technical characteristics

Mechanical characteristics		Measuring characteristics	
Enclosure material	- Extruded anodized aluminium body - Glass filled nylon end caps	Voltage measurement	
Mounting	Wall mounting (2 or 3 fastener locations)	Sampling rate	1.8 kHz
Ingress Protection	IP40	Voltage measurement accuracy	Class 0.2
Conduit connections	Sized for 1-inch EMT conduit connection	Current measurement	
Electrical characteristics		Number of current inputs	MCM-16: 16 MCM-48: 48
Voltage range	2 voltage inputs: - Main voltage input: 90-600 VAC L-N / L-L - CAT III - Secondary voltage input: 90-250 VAC L-N / L-L CAT III	Associated current sensors	- 333 mV current sensors - Rogowski coil sensors (131 mV / kA @ 60 Hz)
Voltage connection	- Main Voltage input: Board mounted terminal block, 5 positions, stranded or solid AWG 12... AWG 14 / 2.5 ... 4 mm ² cable - Secondary voltage input: Removable screw terminal block, 4 positions, stranded or solid AWG 12...AWG 18 / 0.75 ... 4 mm ² cable	CT connection	Board mounted push-in spring terminal block AWG 16 ... AWG 24 / 0.5 ... 1.5 mm ² cable, 600 VAC, twisted pair
Electrical Network (Service) type	Single-Phase - Two-Wire, Line-to-Neutral Single-Phase - Two-Wire, Line-to-Line Single-Phase - Three-Wire (Split-Phase) Three-Phase - Three-Wire (Delta) Three-Phase - Four-Wire (Wye)	Current measurement accuracy	Class 0.1
Frequency range	45 ... 65 Hz	Power and Energy measurement	
Power supply	- Line powered (any two lines 90 - 600 VAC), - 5VDC 500 mA from USB port (offline configuration mode)	Active Power/Energy accuracy	Class 0.2
Environmental characteristics		Communication characteristics	
Storage temperature	-13 to +158 °F / -25 to +70°C	RS485	
Operating temperature	-4 to +140 °F / -20 to +60°C	Connection type	Half-Duplex, 2-3 wires
Humidity	5% to 95% RH / +131°F/+55°C, non condensing	Protocol	Modbus RTU
Operating altitude	≤ 6560 ft / 2000 m	Baudrate	9600 bds - 115200 bds
		Ethernet	
		Connection type	RJ45 10/100 Mbs
		Protocol	Modbus TCP/IP, BACnet IP, MQTT
		USB	
		Connection type	USB Type C
		Function	Firmware upgrade and configuration

Dimensions (in/mm)

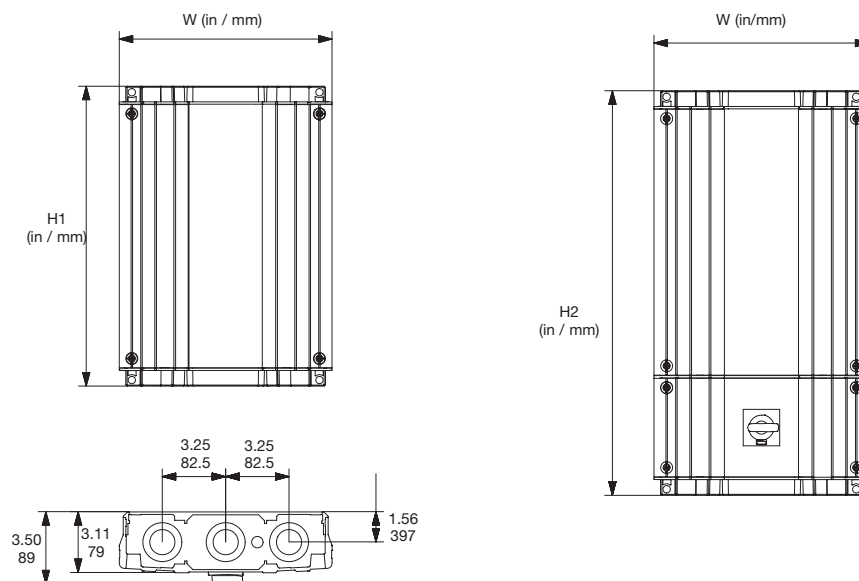

Model	W (in / mm)	H1 (in / mm)	H2 (in / mm)
MCM-16	10.9 / 277	12.4 / 314	-
MCM-16 with disconnect	10.9 / 277	-	17.5 / 444
MCM-48	10.9 / 277	15.4 / 390	-
MCM-48 with disconnect	10.9 / 277	-	20.5 / 521

References

DIRIS MCM enclosed power meters		
DIRIS MCM-16-N-N	Enclosed 16-circuit power meter	4827 16NN
DIRIS MCM-16-D-N	Enclosed 16-circuit power meter with display	4827 16DN
DIRIS MCM-16-D-D	Enclosed 16-circuit power meter with display and disconnect switch	4827 16DD
DIRIS MCM-48-N-N	Enclosed 48-circuit power meter	4827 0548
DIRIS MCM-48-N-D	Enclosed 48-circuit power meter with disconnect switch	4827 0549
DIRIS MCM-48-D-N	Enclosed 48-circuit power meter with display	4827 48DN
DIRIS MCM-48-D-D	Enclosed 48-circuit power meter with display & disconnect switch	4827 48DD

333 mV split-core current sensors						
Model	Primart	Accuracy	Accuracy	Window size (in / mm)	Output Lead Length	Reference
TR-10W	63	3 ... 75.6	0.50%	Ø 0.39 / 10	22 / 7	194S 5010
TR-14W	160	8 ... 192	0.50%	Ø 0.55 / 14	22 / 7	194S 5014
TR-21W	250	12.5 ... 300	0.50%	Ø 0.83 / 21	22 / 7	194S 5021
TR-32W	600	30 ... 720	0.50%	Ø 1.26 / 32	22 / 7	194S 5032
ACTL-0750-20	20	0.2 ... 24	0.75%	0.78 x 0.78 / 20 x 20	8 / 2.4	USACTL0750020
ACTL-0750-20-C06	20	0.2 ... 24	0.50%	0.78 x 0.78 / 20 x 20	8 / 2.4	USACTL0750020C06
ACTL-0750-50	50	0.5 ... 60	0.75%	0.78 x 0.78 / 20 x 20	8 / 2.4	USACTL0750050
ACTL-0750-50-C06	50	0.5 ... 60	0.50%	0.78 x 0.78 / 20 x 20	8 / 2.4	USACTL0750050C06
ACTL-0750-100	100	1 ... 120	0.75%	0.78 x 0.78 / 20 x 20	8 / 2.4	USACTL07500100
ACTL-0750-100-C06	100	1 ... 120	0.50%	0.78 x 0.78 / 20 x 20	8 / 2.4	USACTL07500100C06
ACTL-0750-150	150	1.5 ... 180	0.75%	0.78 x 0.78 / 20 x 20	8 / 2.4	USACTL07500150
ACTL-0750-150-C06	150	1.5 ... 180	0.50%	0.78 x 0.78 / 20 x 20	8 / 2.4	USACTL07500150C06
ACTL-0750-200	200	2 ... 240	0.75%	0.78 x 0.78 / 20 x 20	8 / 2.4	USACTL07500200
ACTL-0750-200-C06	200	2 ... 240	0.50%	0.78 x 0.78 / 20 x 20	8 / 2.4	USACTL07500200C06
ACTL-0750-250	250	2.5 ... 300	0.75%	0.78 x 0.78 / 20 x 20	8 / 2.4	USACTL07500250
ACTL-0750-250-C06	250	2.5 ... 300	0.50%	0.78 x 0.78 / 20 x 20	8 / 2.4	USACTL07500250C06
ACTL-1250-250	250	2.5 ... 300	0.75%	Ø 1.77 x 1.26 / 45 x 32	8 / 2.4	USACTL1250250
ACTL-1250-250-C06	250	2.5 ... 300	0.50%	Ø 1.77 x 1.26 / 45 x 32	8 / 2.4	USACTL1250250C06
ACTL-1250-250-C02	250	2.5 ... 300	0.20%	Ø 1.77 x 1.26 / 45 x 32	8 / 2.4	USACTL1250250C02
ACTL-1250-400	400	4 ... 480	0.75%	Ø 1.77 x 1.26 / 45 x 32	8 / 2.4	USACTL1250400
ACTL-1250-400-C06	400	4 ... 480	0.50%	Ø 1.77 x 1.26 / 45 x 32	8 / 2.4	USACTL1250400C06
ACTL-1250-400-C02	400	4 ... 480	0.20%	Ø 1.77 x 1.26 / 45 x 32	8 / 2.4	USACTL1250400C02
ACTL-1250-600	600	6 ... 720	0.75%	Ø 1.77 x 1.26 / 45 x 32	8 / 2.4	USACTL1250600
ACTL-1250-600-C06	600	6 ... 720	0.50%	Ø 1.77 x 1.26 / 45 x 32	8 / 2.4	USACTL1250600C06
ACTL-1250-600-C02	600	6 ... 720	0.20%	Ø 1.77 x 1.26 / 45 x 32	8 / 2.4	USACTL1250600C02

131mV Rogowski current sensors						
Model	Output Signal	Real range covered (A)	Accuracy	Window size (in / mm)	Output Lead Length (ft/m)	Reference
ROG-80	131mV / kA @ 60Hz Max. 4000 A	10 ... 4000	0.50%	Ø 3.15 / 80	22 ft / 7 m	194S 1080
ROG-120	131mV / kA @ 60Hz Max. 4000 A	10 ... 4000	0.50%	Ø 4.72 / 120	22 ft / 7 m	194S 1120
ROG-200	131mV / kA @ 60Hz Max. 4000 A	10 ... 4000	0.50%	Ø 7.87 / 200	22 ft / 7 m	194S 1200
ROG-300	131mV / kA @ 60Hz Max. 4000 A	10 ... 4000	0.50%	Ø 11.81 / 300	22 ft / 7 m	194S 1300

Wireless System (*)	Description	Reference
RF END-Node	Wireless transmitter with RS485 input (one RF END-Node per DIRIS MCM power meter)	4899 0800
RF HUB-Node	Wireless Hub with Ethernet output (supports up to 8 RF END-Node interfaces)	4899 0801

(*) Refer to RF catalog pages for more information

Commissioning	Description	Reference
1/2-day remote commissioning	Remote commissioning including installation verification, programming and communication testing	9230100027
1/2-day on-site commissioning	On-site commissioning including installation verification, programming and communication testing	9230100004

Expert Services

Our service engineers are an essential part of our team, and they are dedicated to ensuring your power monitoring system provides accurate and reliable measurements to your EPMS software or SCADA system.

Our services include:

- > Site audits to verify the proper wiring of your system
- > Personnel training on how to configure, operate and maintain power monitoring equipment and associated software
- > Remote and on-site commissioning to ensure that your system is up and running quickly, with peace of mind.

For further information, please contact your nearest SOCOMEC branch.



RF END-Node & HUB-Node

Wireless system for sub-metering applications



RF END-Node & HUB-Node

Function

The Socomec RF system is designed to replace Ethernet LAN network infrastructure and Modbus RS485 multi-drop wiring runs with a secure local wireless network. The RF system has been designed to be networked from different locations throughout a facility or campus environment. The RF END-Node has an RS485 input to connect to any Modbus device that needs wireless communication, while the RF HUB-Node converts the wireless communication into an RS485 or Ethernet bus, making compatibility and integration seamless with all EMS/BMS systems.

Advantages

Easy installation

The Socomec RF system is designed to improve installation safety and reduce overall installation time

- Wireless RS485 network saves both time and money eliminating costly wire runs.
- The RF END-Node is self-powered by the DIRIS MCM meter and can be mounted directly on top of it.
- (1) RF HUB-Node can support up to (8) Modbus devices on a network.

Easy commissioning

- Configuration with a simple and intuitive PC application (RF-View) via a direct USB connection to RF HUB-Node.
- Visual signal strength feature guarantees optimal device placement for maximum network coverage.
- (1) RF HUB-Node can support up to (8) different Modbus devices on one network.

Rugged industrial design

- Aluminum body case.
- Extendable and multi-position antenna provides unlimited mounting options and avoids communication losses.
- Easy-access LED status lights.
- RF Encryption ensures data confidentiality.

Programmable / Customizable

- Equipped with an automatic communication retry feature to ensure no data packets go missing.
- PreFetch zone improves data reliability and response time to Modbus Host.
- Assign one RF END-Node to a specific Modbus address.
- Using Test utility allows user to see data results while both on and off site.

General Characteristics

- Behaves as a virtual (wireless) RS485 serial network
- Modbus RTU and TCP communication
- Wireless 915 MHz encrypted
- RF END-Node is directly powered from the DIRIS MCM power meter

The solution for

- > Commercial buildings
- > Retail
- > High density residential
- > Industrial plants



Strong points

- > 128 Bit AES encryption
- > Easy installation
- > Easy PC-based setup
- > Reduce downtime
- > Compact
- > Self-powered

Typical Architecture

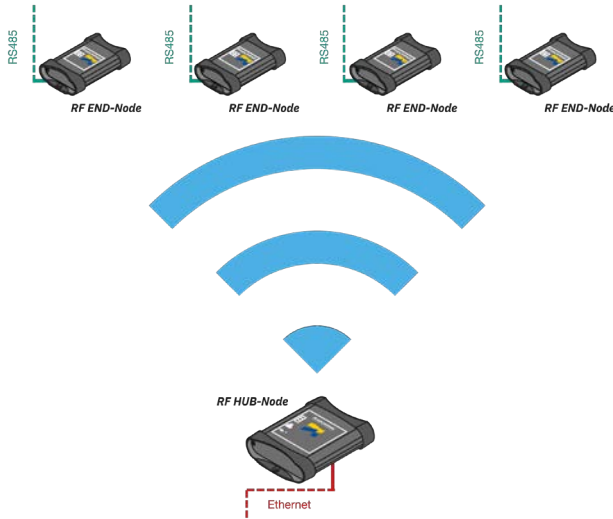

Socomec RF System

Socomec RF system is a general-purpose wireless Modbus system designed to replace RS485 multi-drop wiring installations. The system is designed as a "star" network with a Modbus Master physically connected to the RF HUB-Node which remotely communicates with up to (8) RF END-Nodes. RF END-Nodes are connected via RS485 to power meters or any Modbus enabled devices.

Simple Wireless architecture

The RF system has been designed to be plug and play compatible with the DIRIS MCM meter for wireless communication (915 MHz) of measurements. The RF END-Node is connected via RS485 to the DIRIS MCM and sends measurement via wireless link to the RF HUB-Node. No external power supply is required, as the RF END-Node is self-powered by the DIRIS MCM.

Each RF HUB-Node can communicate wirelessly with up to (8) RF END-Node. The RF HUB-Node offers RS485 (Modbus RTU) and Ethernet (Modbus TCP) communication capabilities to any third-party BMS/EMS system.

PC-based configuration software (RF-View)

The RF system is configured using a simple and Intuitive PC application (RF View) with the following features:

- Assignable (one RF END-Node per address range)
- Automatic Communication Retries
- Configurable "Prefetch" modes – up to 3
- Real Time Signal Strength Indicator

Antennas

Various types of antennas can be connected to the RF system to maximize signal strength.

Socomec has tested a range of antennas from short to high-gain to boost signal strength which make installation easy across a wide range of application environments.

Socomec's standard supplied antenna is a market tested magnetic base with Whip antenna. The lead wire for the base can be extended to optimize antenna location and maximize signal strength.

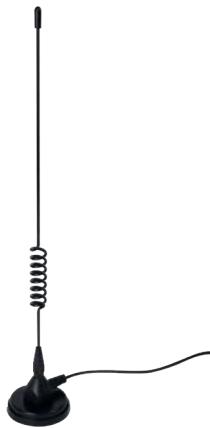

Magnetic antenna base with Omni-directional Whip antenna
(Supplied with RF END-Node and HUB-Node)

RF END-Node & HUB-Node

Wireless system for sub-metering applications

Dimensions (in/mm)

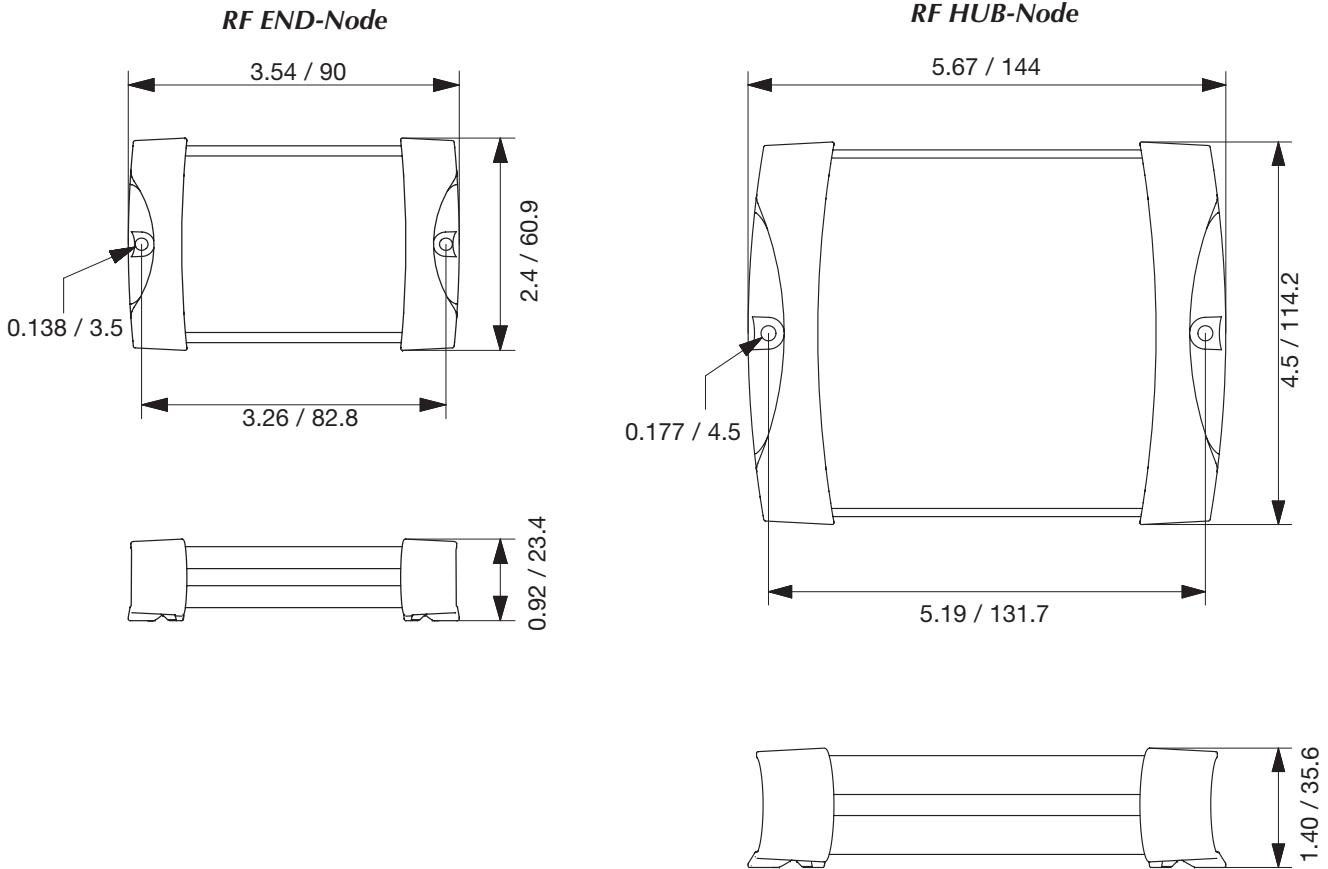

Technical Characteristics

Communication characteristics	RF END-Node	RF HUB-Node
Antenna connection	RSMA	
Frequency	902 - 928 MHZ	
Radio Power	25 dbm	
Encryption	128 Bit AES	
Modulation	FSK	
Link Budget	135 dB	
System Range(s)	5 Miles Outdoor Line of Sight 1000 feet indoor commercial	
Communications	RS485 Modbus RTU	RS485 Modbus RTU Ethernet Modbus TCP

Electrical Characteristics	RF END-Node	RF HUB-Node
Consumption	3 VA	
Power Supply	4.8 - 28 VDC	5.0 VDC
Connection	Molex Minift Jr (2x2)	USB Type B

Environmental Characteristics	RF END-Node	RF HUB-Node
Temperature	-4... +140°F / -20 +60°C	

RF END-Node & HUB-Node

Wireless system for sub-metering applications

References

Wireless System (*)	Description	Reference
RF END-Node	Wireless End-Point interface with RS485 input (one RF END-Node per DIRIS MCM)	4899 0800
RF HUB-Node	Wireless Access-Point interface; RS485 & Ethernet outputs (supports up to 8 RF END-Nodes)	4899 0801

RF END-Node standard kit content:

- (1) Molex Power & Communication cable
- (1) Magnetic Base with 4m / 13.1ft SMA cable
- (1) Whip Antenna

RF HUB-Node standard kit content:

- (1) USB 1 Amp Power Supply (100 - 240 VAC)
- (1) 6-ft USB Cable
- (1) Magnetic Base with 4m / 13.1ft SMA cable
- (1) Whip Antenna

Expert Services

Our service engineers are an essential part of our team, and they are dedicated to ensuring your power monitoring system provides accurate and reliable measurements to your EPMS software or SCADA system.

Our services include:

- > Site audits to verify the proper wiring of your system
- > Personnel training on how to configure, operate and maintain power monitoring equipment and associated software
- > Remote and on-site commissioning to ensure that your system is up and running quickly, with peace of mind.

For further information, please contact your nearest SOCOMEC branch.



TE sensors

Solid-core AC current sensors

For DIRIS Digiware, DIRIS A and DIRIS B

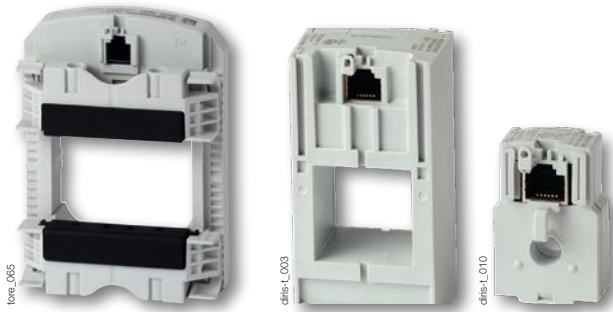

TE solid-core sensors

Function

TE solid-core sensors are used with DIRIS Digiware I, DIRIS A, or DIRIS B Power Monitoring Devices to measure currents from 5 to 2000 A with only 7 part numbers and with the same guaranteed accuracy. The quick RJ12 connection, and the integrated intelligence prevent any connection or configuration errors. Numerous accessories are available to mount the sensors in any type of electrical panel.

Advantages

Plug & Play

- RJ12 concept for a quick and reliable connection to the power meter.
- Color-coded RJ12 cables provides easy phase identification to prevent phase inversions.
- Automatic detection of current sensor type and rating.
- Low-voltage mV output - No shorting blocks are needed, TE sensors can be disconnected safely under load.

Accurate

- Unique PreciSense technology guaranteeing system accuracy according to IEC 61557-12 standard.
- Class 0.5 system accuracy (Power Meter + TE current sensor) from 2% to 120% of rated current.

Smart

- Any wiring mishap, whether it's a phase inversion, a wrong orientation or a configuration error can be corrected via software. Save time, effort and resources, avoiding the hassle of reworking physical wiring on current sensors.

The solution for

- > Industry
- > Building
- > Infrastructure
- > Data center



Strong points

- > Plug & Play
- > Accurate
- > Smart

Conformity to standards

- > UL 61010-1, CSA-C22.2 61010-1, Guide PICQ, File E257746



- > IEC 61557-12



- > ISO 14025



Connection to power meter

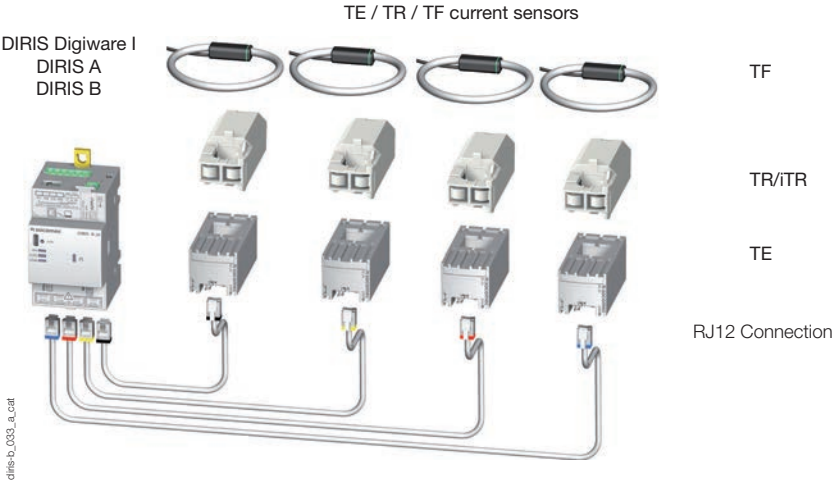

Mounting

Linear assembly with the protective devices
 TE-25 / TE-35 / TE-45 / TE-55 / TE-90



DIN rail mounted



TE-90 clamps

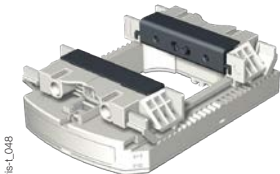

Staggered assembly
 TE-18 / TE-35 / TE-45 / TE-55



Back-plate mounting

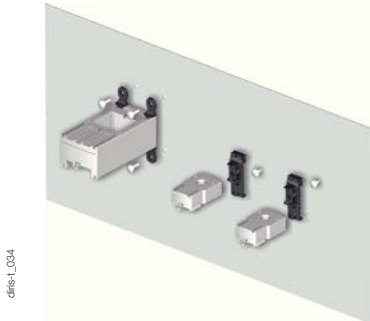

Cable mounting



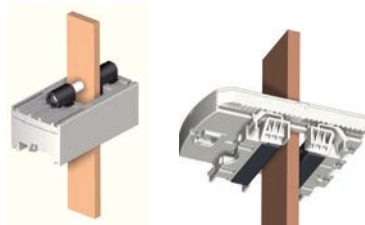

Busbar mounting



Mounting accessories

Mounting accessories delivered with TE sensors:

Switch mounting	TE-18	TE-25	TE-35 TE-45 TE-55	TE-90
 DIN rail and back-plate	1 pc			2 pcs
 DIN rail		2 pcs	2 pcs	
 Back-plate		4 pcs	4 pcs	6 pcs
Busbar			2 pcs	

Additional accessories

Adapter for 1A/5A secondary CT



- Allows to use any existing 1A or 5A secondary current transformers and connect them via an RJ12 cable to DIRIS Digiware I, DIRIS A, and DIRIS B power meters. The adaptor has the dimensions as the TE-18 current sensor.

Coupling link

- Associated with the TE range, this accessory is for inter-connecting the sensors when linear or staggered mounted.

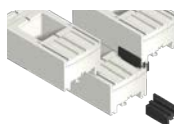

Sealable cover

- The sealable cover prevents tampering and ensures integrity of measurements.



Dimensions (in/mm)

TE - Solid current sensors

TE-18

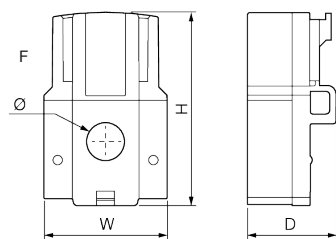

TE-25 / TE-35 / TE-45 / TE-55

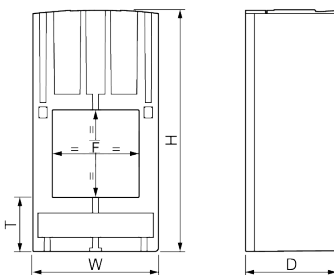

TE-90

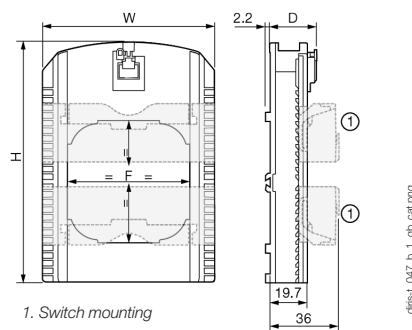

Model	Nominal current range (A)	Actual coverage range (A)	Pitch (in/mm)	H x W x D (in/mm)	Window (in/mm)	T (in/mm)
TE-18	5 ... 20/25 ... 63	0.1 ... 24/0.5 ... 75	0.7/18	1.77 x 1.10 x 0.79/45 x 28 x 20	Ø 0.33/8.6	-
TE-25	40 ... 160	0.8 ... 192	0.98/25	2.56 x 0.98 x 1.28/65 x 25 x 32.5	0.53 x 0.53/13.5 x 13.5	0.69/17.5
TE-35	63 ... 250	1.26 ... 300	1.37/35	2.79 x 1.37 x 1.28/71 x 35 x 32.5	0.82 x 0.82 / 21 x 21	0.69/17.5
TE-45	160 ... 630	3.2 ... 756	1.77/45	3.38 x 1.77 x 1.28/86 x 45 x 32.5	1.22 x 1.22 / 31 x 31	0.77/19.5
TE-55	400 ... 1000	8 ... 1200	2.16/55	3.93 x 2.16 x 1.28/100 x 55 x 32.5	1.61 x 1.61 / 41 x 41	0.85/21.5
TE-90	600 ... 2000	12 ... 2400	3.54/90	4.96 x 3.54 x 0.97/126 x 90 x 24.6	2.52 x 2.52 / 64 x 64	-

Characteristics

TE - Solid current sensors

Model	TE-18	TE-18	TE-25	TE-35	TE-45	TE-55	TE-90
Nominal current range I_n (A)	5 ... 20	25 ... 63	40 ... 160	63 ... 250	160 ... 630	400 ... 1000	600 ... 2000
Actual coverage range (A)	0.1 ... 24	0.5 ... 75	0.8 ... 192	1.26 ... 300	3.2 ... 756	8 ... 1200	12 ... 2400
Max. current (A)	24	75.6	192	300	756	1200	2400
Weight (oz/g)	0.84/24	0.84/24	2.4/69	3.1/89	4.9/140	6.6/187	5.75/163
Max. voltage (phase/neutral)	600 VAC L-N						
Rated withstand voltage	3 kV						
Frequency	50/60 Hz						
Intermittent overload	10 x I_n over 1 sec						
Measurement category	CAT III						
Protection degree	IP30 / IK06						
Operating temperature	+14 °F ... +158 °F / -10 ... +70 °C						
Storage temperature	-13 °F ... +185 °F / -25 ... +85 °C						
Relative humidity	95 % non-condensing						
Operating altitude	≤ 6560 ft feet / 2000 m						
Connection	Specific Socomec RJ12 cables -40 °F ... +185 °F / -40 °C ... +85 °C						

References

Model	Nominal current range (A)	Actual coverage range (A)	Pitch (in/mm)	Reference
TE-18	5 ... 20	0.1 ... 24	0.7/18	4829 0500
TE-18	25 ... 63	0.5 ... 75	0.7/18	4829 0501
TE-25	40 ... 160	0.8 ... 192	0.98/25	4829 0502
TE-35	63 ... 250	1.26 ... 300	1.37/35	4829 0503
TE-45	160 ... 630	3.2 ... 756	1.77/45	4829 0504
TE-55	400 ... 1000	8 ... 1200	2.16/55	4829 0505
TE-90	600 ... 2000	12 ... 2400	3.54/90	4829 0506

Accessories	Reference
Coupling link (20 linear assembly parts and 10 for staggered assembly)	4829 0598
1A/5A secondary CT adapter with RJ12 output for DIRIS Digiware, DIRIS A and DIRIS B	4829 0599
Sealable covers (20 pieces)	4829 0600

RJ12 sensor lead cables	Cable length (ft/m)										
	0.32/0.1	0.64/0.2	0.96/0.3	1.64/0.5	3.3/1	6.5/2	9.84/3	16.4/5	23/7	32.8/10	164/50 + 100 connectors
Number of cables	Reference	Reference	Reference	Reference	Reference	Reference	Reference	Reference	Reference	Reference	Reference
1	-	-	-	-	-	-	-	-	-	-	4829 0601
3	4829 0580	4829 0581	4829 0582	4829 0595	4829 0583	4829 0584	4829 0606	4829 0607	4829 0608	4829 0603	4829 0609
4	-	-	-	4829 0596	4829 0588	4829 0589	-	-	-	-	-
6	4829 0590	4829 0591	4829 0592	4829 0597	4829 0593	4829 0594	-	-	-	-	-

TR/iTR sensors

Split-core AC current sensors

For DIRIS Digiware, DIRIS A and DIRIS B



TR Split-core current sensors

Function

TR/iTR split-core current sensors are used with DIRIS Digiware I, DIRIS A, or DIRIS B Power Monitoring Devices to measure currents from 25 to 600 A, with the same guaranteed accuracy. The quick RJ12 connection, and the integrated intelligence prevent, any wiring or configuration errors.

TR/iTR split-core sensors are placed around the live conductors without disrupting the wiring and the supply, highly convenient for retrofit applications.

Advantages of the TR and iTR sensors

Plug & Play

- RJ12 concept for a quick and reliable connection to the power meter.
- Color-coded RJ12 cables provides easy phase identification to prevent phase inversions.
- Automatic detection of current sensor type and rating.
- Low-voltage mV output - No shorting blocks are needed, TR sensors can be disconnected safely under load.

Smart

- Any wiring mishap, whether it's a phase inversion, a wrong orientation or a configuration error can be corrected via software.
- Save time, effort and resources, avoiding the hassle of reworking physical wiring on current sensors.

Accurate

- Unique PreciSense technology guaranteeing system accuracy according to IEC 61557-12 standard.
- Class 0.5 system accuracy (Power Meter + iTR current sensor) and class 1 system accuracy (Power Meter + TR sensor) from 2% to 120% of rated current.)

Unique advantages of the iTR range

VirtualMonitor technology

VirtualMonitor provides a smart monitoring of protective device status:

- Real time Position & Trip.
- Alarms in case of Opening or Trip.
- With no additional hardware or wiring (no auxiliary contacts needed)

AutoCorrect technology

AutoCorrect technology guarantees that your power monitoring system provides reliable measurements:

- Automatic detection of commissioning errors (phase inversion, wrong orientation etc.).
- Even available off-load using a voltage sensing technology.

The solution for

- > Retrofit applications
- > Industry
- > Building
- > Infrastructure
- > Data centers



Strong points

- > Plug & Play
- > Accurate
- > Smart

Integrated technologies ⁽¹⁾



For more information see our website www.socomec.us

⁽¹⁾ AutoCorrect and VirtualMonitor are only available with iTR sensors.

Compliance with standards

- > UL 61010, CSA-C22.2 No. 61010-1, Guide PICQ, File E257746
- > IEC 61557-12



- > ISO 14025



Create your project

- > Find the best DIRIS Digiware configuration:

www.meter-selector.com

METER SELECTOR
DIGITAL TOOL AVAILABLE

Installation

Cable mounting

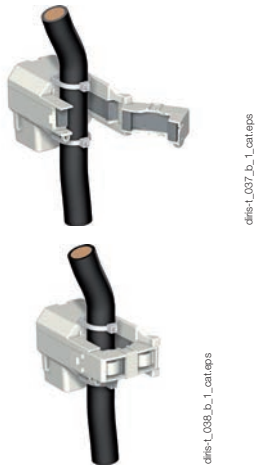

Dimensions (in/mm)

TR/iTR-10 / TR/iTR-14 / TR/iTR-21 / TR/iTR-32

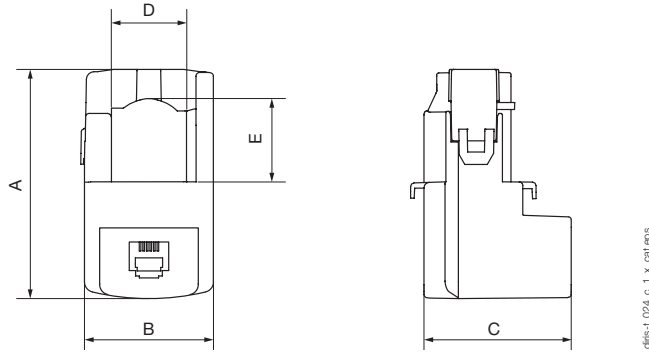

Model	Nominal current range (A)	Actual coverage range (A)	A (in/mm)	B (in/mm)	C (in/mm)	D (in/mm)	E (in/mm)	Ø (in/mm)
TR/iTR-10	25 ... 63	0.5 ... 75.6	1.73/44	1.02/26	1.10/28	-	-	0.39/10
TR/iTR-14	40 ... 160	0.8 ... 192	2.64/67	1.14/29	1.10/28	0.55/14	0.59/15	0.55/14
TR/iTR-21	63 ... 250	1.26 ... 300	2.56/65	1.46/37	1.69/43	0.83/21	0.91/23	0.83/21
TR/iTR-32	160 ... 600	3.2 ... 720	3.39/86	2.09/53	1.85/47	1.26/32	1.30/33	1.26/32

Technical characteristics

Model	TR-10	iTR-10	TR-14	iTR-14	TR-21	iTR-21	TR-32	iTR-32
Nominal current range I_n (A)	25 ... 63		40 ... 160		63 ... 250		160 ... 600	
Actual coverage range (A)	0.5 ... 75.6		0.8 ... 192		1.26 ... 300		3.2 ... 720	
Max. current (A)	75.6		192		300		720	
Weight (oz/g)	2.6/74		4.1/117		7.4/211		10.9/311	
Max. voltage (phase/neutral)	600 VAC L-N							
Rated withstand voltage	3 kV							
Frequency	50/60 Hz							
Intermittent overload	$10 \times I_n$ for 1 s							
Measurement category	CAT III							
Accuracy class when used with DIRIS Digiware I, DIRIS A, DIRIS B	Class 1	Class 0.5	Class 1	Class 0.5	Class 1	Class 0.5	Class 1	Class 0.5
Protection degree	IP20 / IK07							
Operating temperature range	+14 °F ... +158 °F / -10 ... +70 °C						+14 °F ... +131 °F / -10 ... +70 °C	
Storage temperature range	-13 °F ... +185 °F / -25 to +85 °C							
Relative humidity	95% RH non-condensing							
Operating altitude	≤ 6560 ft feet / 2000 m							
Connection	Specific Socomec RJ12 cables							

References

Model	Nominal current range (A)	Actual coverage range (A)	Ø (in/mm)	Part number
TR-10	25 ... 63	0.5 ... 75	0.39/10	4829 0555
TR-14	40 ... 160	0.8 ... 192	0.55/14	4829 0556
TR-21	63 ... 250	1.26 ... 300	0.83/21	4829 0557
TR-32	160 ... 600	3.2 ... 720	1.26/32	4829 0558

Model	Nominal current range (A)	Actual coverage range (A)	Ø (in/mm)	Part number
iTR-10	25 ... 63	0.5 ... 75	0.39/10	4829 0655
iTR-14	40 ... 160	0.8 ... 192	0.55/14	4829 0656
iTR-21	63 ... 250	1.26 ... 300	0.83/21	4829 0657
iTR-32	160 ... 600	3.2 ... 720	1.26/32	4829 0658

RJ12 sensor lead cables	Cable length (ft/m)										
	0.32/0.1	0.64/0.2	0.96/0.3	1.64/0.5	3.3/1	6.5/2	9.84/3	16.4/5	23/7	32.8/10	164/50 + 100 connectors
Number of cables	Reference	Reference	Reference	Reference	Reference	Reference	Reference	Reference	Reference	Reference	Reference
1	-	-	-	-	-	-	-	4829 0602	-	4829 0603	4829 0601
3	4829 0580	4829 0581	4829 0582	4829 0595	4829 0583	4829 0584	4829 0606	4829 0607	4829 0608	4829 0609	-
4	-	-	-	4829 0596	4829 0588	4829 0589	-	-	-	-	-
6	4829 0590	4829 0591	4829 0592	4829 0597	4829 0593	4829 0594	-	-	-	-	-

TF sensors

Flexible Rogowski AC current sensors

For DIRIS Digiware, DIRIS A and DIRIS B



diris-L_005.png

TF Flexible current sensors

Function

TF flexible **Rogowski coil current sensors** are used with DIRIS Digiware I, DIRIS A, or DIRIS B Power Monitoring Devices to measure currents from 100 to 6000 A with the same guaranteed accuracy. The quick RJ12 connection, and the integrated intelligence prevent any connection or configuration errors.

TF current sensors provide a versatile solution when space is limited, wrapped around irregular-shaped conductors or busbars without disrupting the wiring and the supply, highly convenient in retrofit applications. No external power supply is needed, as the sensor is powered from the power meter through the RJ12 connection.

Advantages

Plug & Play

- RJ12 concept for a quick and reliable connection to the power meter.
- Automatic detection of current sensor type and rating.
- Low-voltage mV output - No shunting blocks are needed, TF sensors can be disconnected safely under load.

Accurate

- Unique PreciSense technology guaranteeing system accuracy according to IEC 61557-12 standard.
- Class 0.5 system accuracy (Power Meter + TF current sensor) from 2% to 120% of rated current.
- Accuracy is guaranteed regardless of the position of the conductor in the loop.

Safe locking mechanism

- The locking system prevents the loop from opening, guaranteeing continuous functioning and accuracy even under harsh conditions.

Smart

- Any wiring mishap, whether it's a phase inversion, a wrong orientation or a configuration error can be corrected via software. Save time, effort and resources, avoiding the hassle of reworking physical wiring on current sensors.

Simplified installation

- The Rogowski integrator is built into the RJ12 cable enabling a quick and compact integration (no DIN rail assembly required) inside electrical panels.
- The integrator is self-supplied by the power meter through the RJ12 cable and does not need an external power supply.

The solution for

- > Industry
- > Building
- > Infrastructure
- > Data centers

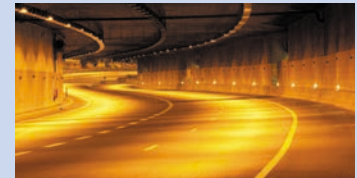

Strong points

- > Plug & Play
- > Smart
- > Simplified installation

Integrated technologies



PreciSense

For more information see our website
www.socomec.us

Compliance with standards

- > UL 61010-1, CSA-C22.2 No 61010-1, Guide PICQ, IEC 61557-12



- > IEC 61557-12



- > ISO 14025

Create your project

- > Find the best DIRIS Digiware configuration:
www.meter-selector.com



Installation

Cable mounting



diris-L_079_a.png

Bar mounting

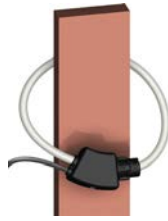

diris-L_080_a.png

Dimensions (in / mm)

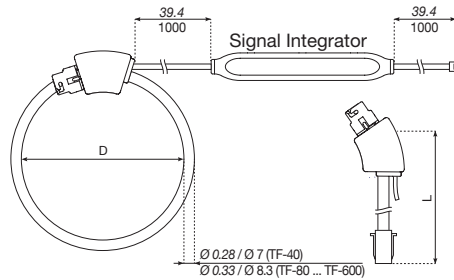

diris-L_079_c_diris.it

Model	Nominal current range (A)	Real range covered (A)	D (in/mm)	L = Loop length (in/mm)
TF-40	100 ... 400	2 ... 480	1.57 / 40	4.96 / 126
TF-80	150 ... 600	3 ... 720	3.15 / 80	9.88 / 251
TF-120	400 ... 2000	8 ... 2400	4.72 / 120	14.84 / 377
TF-200	600 ... 4000	12 ... 4800	7.87 / 200	24.72 / 628
TF-300	1600 ... 6000	32 ... 7200	11.81 / 300	37.09 / 942
TF-600	1600 ... 6000	32 ... 7200	23.62 / 600	74.21 / 1885

Integrator dimensions (in / mm): 5.04 x 0.75 x 0.59 / 128 x 19 x 15

Technical characteristics

Model	TF-40	TF-80	TF-120	TF-200	TF-300	TF-600
Nominal current range I_n (A)	100 ... 400	150 ... 600	400 ... 2000	600 ... 4000	1600 ... 6000	1600 ... 6000
Actual range covered (A)	2 ... 480	3 ... 720	8 ... 2400	12 ... 4800	32 ... 7200	32 ... 7200
Weight (oz/g)	4/114	4.85/130	5/142	5.78/164	6.81/193	9.67/274
Max. voltage (phase/neutral)	600 VAC L-N					
Rated withstand voltage	3.6 kV					
Accuracy class	Class 0.5 system accuracy when used with DIRIS Digiware I, DIRIS A, DIRIS B					
Frequency	50 / 60 Hz					
Intermittent overload	10 x I_n for 1 s					
Measurement category	CAT III					
Protection degree	IP30 / IK07					
Operating temperature	+ 14°F ... + 158°F / -10°C to +70°C					
Storage temperature	- 13°F ... +185°F / -25°C to +85°C					
Relative humidity	95% RH non-condensing					
Operating altitude	≤ 6560 ft / 2000 m					
Connection	Specific Socomec RJ12 cables					

References

Model	Nominal current range (A)	Real range covered (A)	Window Diameter (in / mm)	Reference
TF-40	100 ... 400	2 ... 480	1.57 / 40	4829 0573
TF-80	150 ... 600	3 ... 720	3.15 / 80	4829 0574
TF-120	400 ... 2000	8 ... 2400	4.72 / 120	4829 0575
TF-200	600 ... 4000	12 ... 4800	7.87 / 200	4829 0576
TF-300	1600 ... 6000	32 ... 7200	11.81 / 300	4829 0577
TF-600	1600 ... 6000	32 ... 7200	23.62 / 600	4829 0578

Accessories

Female/female connector for extension of the RJ12 connection between power meter and TF sensor.

Reference

4829 0670

RJ12 sensor lead cables	Cable length (ft/m)										
	0.32/0.1	0.64/0.2	0.96/0.3	1.64/0.5	3.3/1	6.5/2	9.84/3	16.4/5	23/7	32.8/10	164/50 + 100 connectors
Number of cables	Reference	Reference	Reference	Reference	Reference	Reference	Reference	Reference	Reference	Reference	Reference
1	-	-	-	-	-	-	-	4829 0602	-	4829 0603	4829 0601
3	4829 0580	4829 0581	4829 0582	4829 0595	4829 0583	4829 0584	4829 0606	4829 0607	4829 0608	4829 0609	-
4	-	-	-	4829 0596	4829 0588	4829 0589	-	-	-	-	-
6	4829 0590	4829 0591	4829 0592	4829 0597	4829 0593	4829 0594	-	-	-	-	-

DC current sensors

Associated with DIRIS Digiware DC

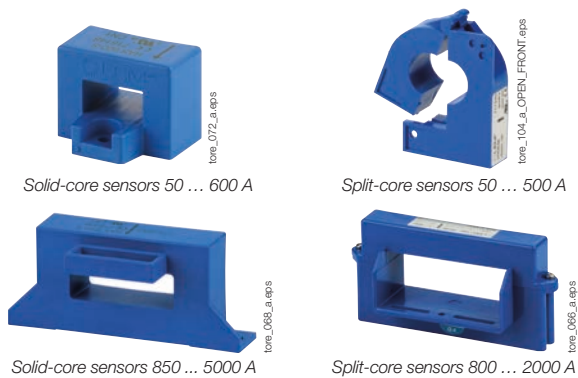

Function

The **DC current sensors** measure the DC load currents of an electrical installation and transmit information to the DIRIS Digiware Idc measurement modules via an RJ12 cable.

The range consists of solid-core and split-core sensors ranging from 50 to 5000 A in various sizes allowing them to be used in new or existing electrical installations.

Up to 3 different DC sensors can be connected to the same DIRIS Digiware Idc module.

Advantages

Plug & Play

- A quick RJ12 connection makes wiring easy and reliable.
- Fast configuration of the current sensors.

Flexible

- A complete range of solid-core and split-core sensors from 50 to 5000 A designed for new or existing electrical installations.

Installation

- Easy to install.
- Ideal for installations with limited space available.
- Only 4 different frame sizes cover a wide measurement range.
- Color-coded cables for ease of identification, and to prevent wiring errors.

Bi-Directional Metering

- DIRIS Digiwar DC measure the flow of electricity in both directions.

The solution for

- > Data center
- > Telecommunication
- > Renewable power
- > Transportation



Strong points

- > Plug & Play
- > Wide selection of ratings
- > Simplified installation

Compliance with standards

- > UL 508, CSA-C22.2 No. 14, Guide NMTR, File E189713
- > IEC 61010-1



Dimensions (in/mm)

Solid-core sensors 50 ... 600 A (frame size 1)

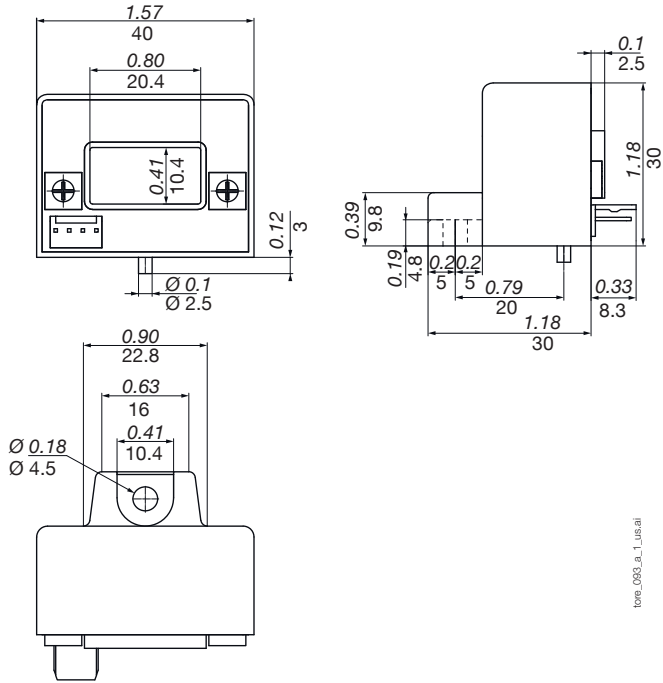

Solid-core sensors 850 ... 5000 A (frame size 2)

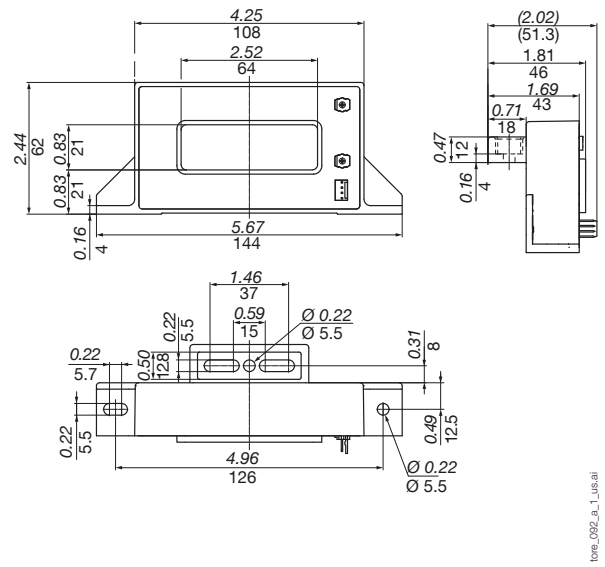

Split-core sensors 50 ... 500 A (frame size 1)

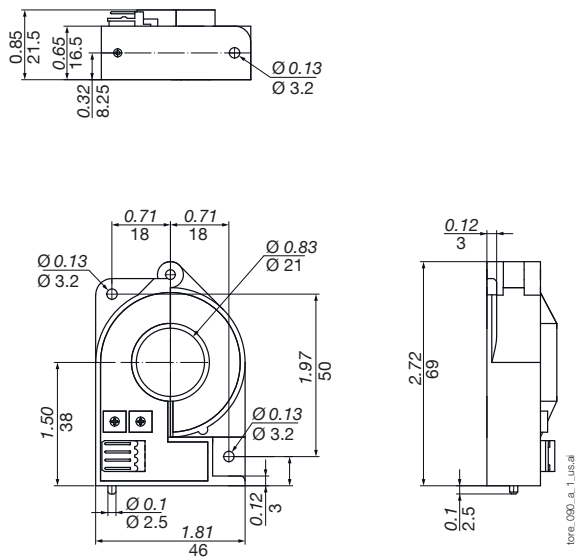

Split-core sensors 800 ... 2000 A (frame size 2)

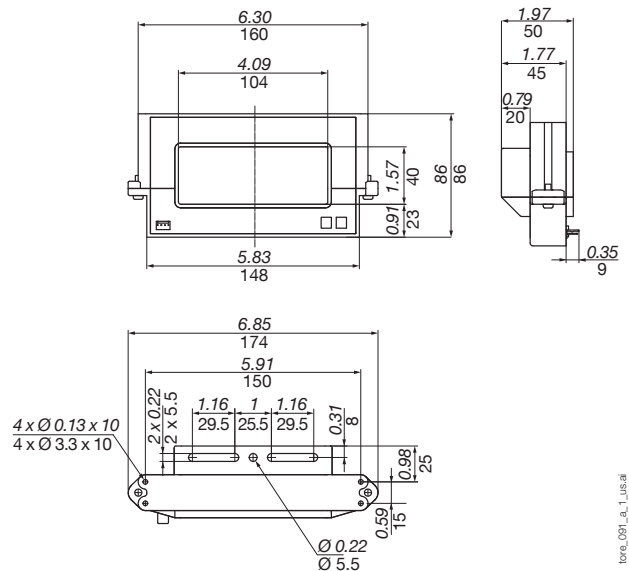

DC current sensors

Associated with DIRIS Digiware DC

Connections

DC current is measured by external sensors connected to the DIRIS Digiware I-3xdc modules via RJ12-Molex cables. Connection of the current sensors is quick and error-free. A wide range of current sensors is available from Socomec to suit all installations and applications including split-core current sensors for retrofit applications.

The DC current sensors have the following technical characteristics:

- Open-loop Hall effect sensors.
- Solid-core or split-core.
- Power supply voltage: ± 15 V.
- Power supply current: ± 25 mA depending on the sensor.
- Output voltage: ± 4 V.
- 4-point male Molex terminal strip.
- Measurement range: 16 to 5000 A.
- Category III overvoltage.

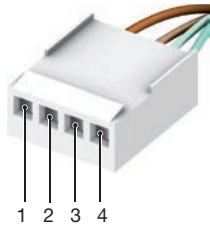

- PIN 1: + 15 V (+ Vc)
- PIN 2: - 15 V (- Vc)
- PIN 3: sensor input (M)
- PIN 4: 0 V sensor (O)

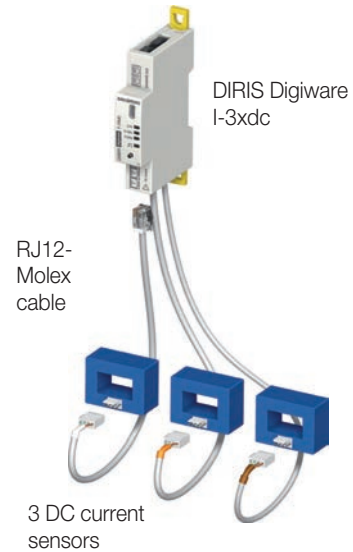

Technical characteristics

Type of current sensor	Open-loop Hall effect
Connection	Specific Socomec cable with RJ12-Molex connectors
Accuracy of current measurement	Solid-core sensors: 50 ... 600 A: < 1% Solid-core sensors: 850 ... 5000 A: < 1% Split-core sensors: 50 ... 500 A: < 2% Split-core sensors: 800 ... 2000 A: < 2%

Weight	Solid-core sensors 50 ... 600 A	2.12 oz / 60 g
	Solid-core sensors 850 ... 5000 A	15.87 oz / 450 g
	Split-core sensors 50 ... 500 A	2.82 oz / 80 g
	Split-core sensors 800 ... 2000 A	20.8 oz / 590 g
Operating temperature	Solid-core sensors 50 ... 600 A	+14 °F ... +176 °F / -10 ... +80 °C
	Solid-core sensors 850 ... 5000 A	-13 °F ... +185 °F / -25 ... +85 °C
	Split-core sensors 50 ... 500 A	+14 °F ... +158 °F / -10 ... +70 °C
	Split-core sensors 800 ... 2000 A	+14 °F ... +158 °F / -10 ... +70 °C
Storage temperature	Solid-core sensors 50 ... 600 A	-13 °F ... +176 °F / -25 ... +80 °C
	Solid-core sensors 850 ... 5000 A	-13 °F ... +185 °F / -25 ... +85 °C
	Split-core sensors 50 ... 500 A	-4 °F ... +185 °F / -20 ... +85 °C
	Split-core sensors 800 ... 2000 A	-13 °F ... +185 °F / -25 ... +85 °C

References

DC current sensors	Reference
Solid-core sensors (frame size 1)	
50 A	4829 0700
100 A	4829 0701
200 A	4829 0702
300 A	4829 0703
400 A	4829 0704
500 A	4829 0705
600 A	4829 0706
Solid-core sensors (frame size 2)	
850 A	4829 0707
1000 A	4829 0708
1500 A	4829 0709
2000 A	4829 0710
2500 A	4829 0711
5000 A	4829 0712
Split-core sensors (frame size 1)	
50 A	4829 0750
100 A	4829 0751
200 A	4829 0752
300 A	4829 0753
400 A	4829 0754
500 A	4829 0755
Split-core sensors (frame size 2)	
800 A	4829 0756
1000 A	4829 0757
1500 A	4829 0758
2000 A	4829 0759

RJ12-MOLEX cables		
Number of cables	Length of cables	Reference
3	0.98 feet / 0.3 m	4829 0782
3	1.64 feet / 0.50 m	4829 0783
3	3.28 feet / 1 m	4829 0784
3	6.56 feet / 2 m	4829 0785
1	16.4 feet / 5 m	4829 0786

Accu[®]-CT sensors

333mV split-core AC current sensors

20 to 600 A



ACTL-1250

ACTL-0750

Function

The **Accu@-CT** are hinged split-core current sensors, ideal for retrofit applications. They are available in two window opening sizes and offer a wide measurement range from 20 to 600 A. Their 333 mV output signal makes them compatible with DIRIS A-100/A-200 (333 mV models), WattNode and DIRIS MCM power meters, or any third party meter accepting 333 mV current sensors.

Advantages

High Accuracy

The patented Accu@-CT split-core current transformer technology delivers exceptional linearity and low phase angle error, essential for accurate power and energy measurements.

Safe

Built-in burden resistor provides 0.333 Vac voltage output at the rated full scale current, eliminating the need for shunting blocks.

Robust

All materials that make up the current transformers of the Accu@-CT range are cULus 2808 listed. This provides great tolerance against thermal and electric heating as well as a higher dielectric resistance.

Easy to install

The unique one-handed opening and closing mechanism makes installation a snap, even while wearing safety gloves, as well as a higher dielectric resistance.

The solution for

- > Energy
- > Infrastructure & Transport
- > Industry
- > Building

Strong points

- > High accuracy
- > Safe
- > Robust
- > Easy to install

Conformity to standards

- > UL 2808, CSA-C22.2 No. 61010-1, File E363660
- > IEEE/ANSI C57.13
- > IEC 61869-1



Associated products

- > DIRIS A-100/A-200 mV models)
- > WattNode
- > DIRIS MCM



Dimensions (in/mm)

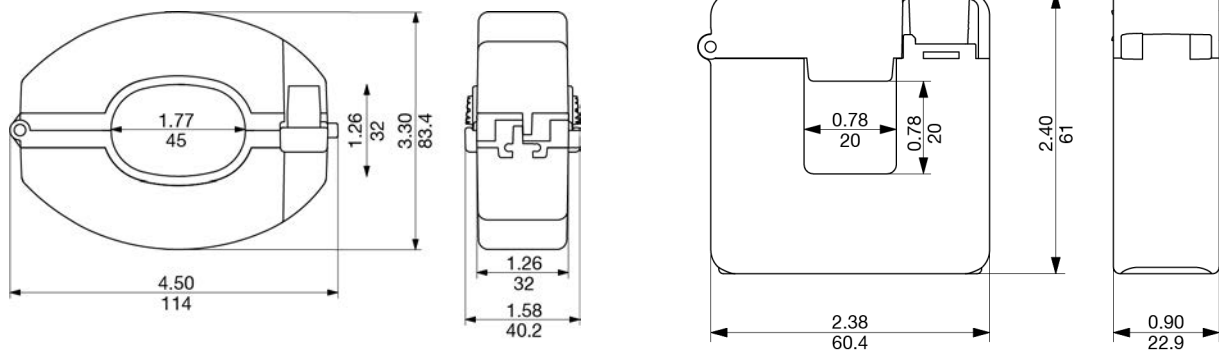

Technical characteristics

Series	Accu®-CT	
Model	ACTL-0750	ACTL-1250
Secondary signal	0.333 VAC	
Voltage rating	CAT IV 250 VAC CAT III 600 VAC	
Output lead wires	White/Black, 20 AWG, 600V, twisted pair wires	
Lead length	8 / 2.43	
Orientation	Arrow points towards source Label faces source	
UL compliance	UL 2808, CAN/CSA-C22.2 No. 61010-1	
Operating temperature	-22°F to 131°F / -30°C to 55°C	-22°F to 167°F / -30°C to 75°C
Operating altitude	≤ 9840 ft / 3000 m	
Operating humidity	5 to 95% RH, non-condensing	

References

Model	Primary rating (A)	Real range covered (A)	Accuracy	Window size (in/mm)	Output lead length (ft / m)	Reference
ACTL-0750-20	20	0.2 ... 24	0.75%	0.78 x 0.78 / 20 x 20	8 / 2.4	USACTL0750020
ACTL-0750-20-C06	20	0.2 ... 24	0.50%	0.78 x 0.78 / 20 x 20	8 / 2.4	USACTL0750020C06
ACTL-0750-50	50	0.5 ... 60	0.75%	0.78 x 0.78 / 20 x 20	8 / 2.4	USACTL0750050
ACTL-0750-50-C06	50	0.5 ... 60	0.50%	0.78 x 0.78 / 20 x 20	8 / 2.4	USACTL0750050C06
ACTL-0750-100	100	1 ... 120	0.75%	0.78 x 0.78 / 20 x 20	8 / 2.4	USACTL07500100
ACTL-0750-100-C06	100	1 ... 120	0.50%	0.78 x 0.78 / 20 x 20	8 / 2.4	USACTL07500100C06
ACTL-0750-150	150	1.5 ... 180	0.75%	0.78 x 0.78 / 20 x 20	8 / 2.4	USACTL07500150
ACTL-0750-150-C06	150	1.5 ... 180	0.50%	0.78 x 0.78 / 20 x 20	8 / 2.4	USACTL07500150C06
ACTL-0750-200	200	2 ... 240	0.75%	0.78 x 0.78 / 20 x 20	8 / 2.4	USACTL07500200
ACTL-0750-200-C06	200	2 ... 240	0.50%	0.78 x 0.78 / 20 x 20	8 / 2.4	USACTL07500200C06
ACTL-0750-250	250	2.5 ... 300	0.75%	0.78 x 0.78 / 20 x 20	8 / 2.4	USACTL07500250
ACTL-0750-250-C06	250	2.5 ... 300	0.50%	0.78 x 0.78 / 20 x 20	8 / 2.4	USACTL07500250C06
ACTL-1250-250	250	2.5 ... 300	0.75%	Ø 1.77 x 1.26 / 45 x 32	8 / 2.4	USACTL1250250
ACTL-1250-250-C06	250	2.5 ... 300	0.50%	Ø 1.77 x 1.26 / 45 x 32	8 / 2.4	USACTL1250250C06
ACTL-1250-250-C02	250	2.5 ... 300	0.20%	Ø 1.77 x 1.26 / 45 x 32	8 / 2.4	USACTL1250250C02
ACTL-1250-400	400	4 ... 480	0.75%	Ø 1.77 x 1.26 / 45 x 32	8 / 2.4	USACTL1250400
ACTL-1250-400-C06	400	4 ... 480	0.50%	Ø 1.77 x 1.26 / 45 x 32	8 / 2.4	USACTL1250400C06
ACTL-1250-400-C02	400	4 ... 480	0.20%	Ø 1.77 x 1.26 / 45 x 32	8 / 2.4	USACTL1250400C02
ACTL-1250-600	600	6 ... 720	0.75%	Ø 1.77 x 1.26 / 45 x 32	8 / 2.4	USACTL1250600
ACTL-1250-600-C06	600	6 ... 720	0.50%	Ø 1.77 x 1.26 / 45 x 32	8 / 2.4	USACTL1250600C06
ACTL-1250-600-C02	600	6 ... 720	0.20%	Ø 1.77 x 1.26 / 45 x 32	8 / 2.4	USACTL1250600C02

TR-W sensors

333 mV split-core AC current sensors
63 to 600 A



TR-W
333 mV

Function

The TR-W are hinged split-core AC current sensors available in 63 A, 160 A, 250 A and 600 A primary rated currents. Their 333 mV output signal makes them compatible with DIRIS A-100/A-200 (333 mV models), WattNode and DIRIS MCM power meters, or any third party meter accepting 333 mV current sensors.

The compactness and low voltage output signal of the TR-W series make them ideal for retrofit applications with existing electrical panels having limited space.

The TR-W split-core series are cULus 61010 listed, certified by Underwriters Laboratory (UL).

Advantages

Plug & Play

- Split-core concept facilitates installation without disconnecting electrical wires inside panel.
- Built-in burden resistor provides 333 mV voltage output at the rated full scale current, eliminating the need for shunting blocks.

Long lead wires

The TR-W series come with standard 22-ft / 7m twisted pair lead wires, ideal for remote meter installation. This reduces installation downtime and costly wire extensions and materials, which typically increase the risk of wiring errors.

Compact

The compact design of the TR-W split-core series make them ideal for applications where space is limited, such as existing panelboards.

Accurate

The TR-W split-core sensors deliver a 0.5% accuracy per IEC 61869 over a wide range from 10 – 120% of the rated current, essential for accurate power and energy measurements.

Tamper proof

The TR-W current sensors can be sealed to prevent and detect possible tampering, which would alter energy readings.

The solution for

- > Buildings
- > Industry
- > Data center
- > Renewables

Strong points

- > Compact
- > Safe installation
- > Accurate
- > Tamper proof
- > Long lead wires

Conformity to

- > UL 61010, CSA-C22.2 No.61010-1, File E257746



- > IEC 61869-2



Associated products

- > DIRIS A-100/A-200 mV models)



- > WattNode



- > DIRIS MCM



Dimensions (in / mm)

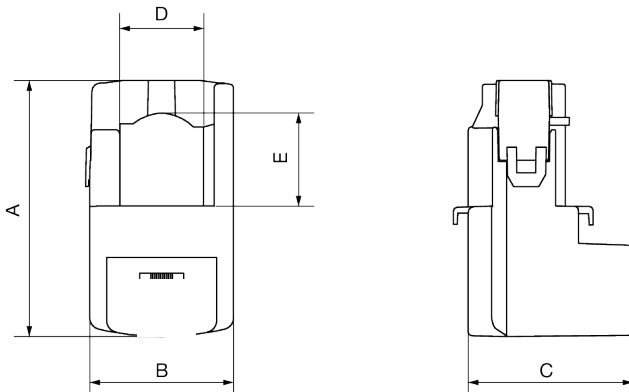

Model	A (in/mm)	B (in/mm)	C (in/mm)	D x E (in/mm)
TR-10W	1.73/44	1.02/26	1.10/28	∅ 0.39/10
TR-14W	2.64/67	1.14/29	1.10/28	0.55/14 x 0.59/15
TR-21W	2.56/65	1.46/37	1.69/43	0.83/21 x 0.91/23
TR-32W	3.39/86	2.09/53	1.85/47	1.26/32 x 1.30/33

Technical Characteristics

Ideal for retrofit applications - compact space	Split-core 333 mV current sensors			
	TR-10W	TR-14W	TR-21W	TR-32W
Primary rating (A)	63	160	250	600
Secondary signal	0.333 VAC			
Output lead wires	White/Black, 22 AWG, 600V, twisted pair wires with solder dipped tinned ends			
Lead length (ft / m)	22 / 7			
Accuracy	0.5%			
Voltage rating	600 VAC L-N			
Orientation	Arrow points towards load			
UL compliance	UL 61010, CAN / CSA-C22.2 No. 61010-1			
Operating temperature	+14 ... +158°F / -10 ... +70°C			
Operating altitude	≤ 6560 ft / 2000 m			
Operating humidity	95% RH without condensation			

References

Model	Primary rating (A)	Secondary	Window (in/mm)	Reference
TR-10W	63	333 mV	∅ 0.39/10	194S 5010
TR-14W	160	333 mV	0.55/14 x 0.59/15	194S 5014
TR-21W	250	333 mV	0.83/21 x 0.91/23	194S 5021
TR-32W	600	333 mV	1.26/32 x 1.30/33	194S 5032

ROG

Flexible rope style AC current sensors - 131 mV
Up to 4000 A



ROG
131 mV / 1 kA

Function

The ROG Rogowski current sensors are flexible rope style AC current sensors available in four diameters (80mm, 120mm, 200mm and 300mm).

These Rogowski sensors deliver an output signal of 131 mV / 1000 A @60Hz, and are compatible with the DIRIS MCM power meters, with no additional integrator or power supply required.

The rope style and the low voltage output signal make them non-intrusive and ideal for retrofit applications with existing electrical panels having limited space.

They are ideal for applications with high currents, busbars and multiple sets of parallel conductors where conventional rectangular or rigid split-core sensors will not fit.

Advantages

Safe installation

- The open-ended design facilitates installation without disconnecting electrical wires inside the panel.
- Built-in burden resistor provides 131 mV voltage output at the rated full scale current, eliminating the need for shorting blocks.

Flexible installation

The rope-style concept provide significant installation flexibility for cable bundles, busbars and irregularly shaped conductors, where conventional rectangular or rigid CTs will not fit.

Safe locking mechanism

The locking mechanism prevents the loop from opening accidentally, guaranteeing continuous functioning and accuracy even under harsh conditions.

Accurate

The ROG split-core sensors deliver linear 0.5% accuracy across a wide current range, essential for accurate power and energy measurements.

Long lead wires

The ROG series come with standard 22-ft / 7m 3-wire output lead, ideal when the meter is installed remote from the electrical panel. This reduces the need for contractors to extend and splice wire leads which typically increases the risk of wiring errors.

The solution for

- > Buildings
- > Industry
- > Datacenter
- > Renewables

The solution for

- > Safe installation
- > Flexible installation
- > Accurate
- > Long lead wires
- > Safe locking mechanism

Conformity to

- > UL 61010, CSA-C22.2 No.61010-1, File E257746



- > IEC 61869-2



Associated products

- > DIRIS MCM



Dimensions (in / mm)

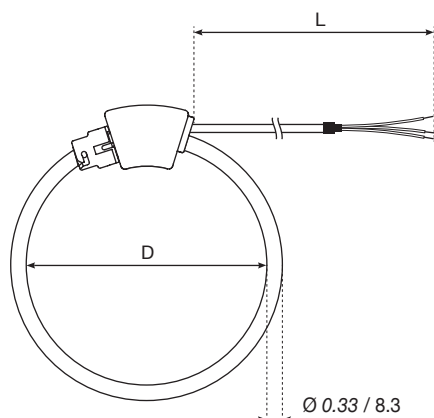

Model	D (in/mm)	Loop length (in/mm)	L (ft/m)
ROG-80	3.15 / 80	9.88 / 251	22 / 7
ROG-120	4.72 / 120	14.84 / 377	22 / 7
ROG-200	7.87 / 200	24.72 / 628	22 / 7
ROG-300	11.81 / 300	37.09 / 942	22 / 7

Technical Characteristics

Ideal for busbars or higher currents	Rogowski 131 mV current sensors			
	ROG-80	ROG-120	ROG-200	ROG-300
Maximum input current	4000 A			
Secondary signal	131 mV / kA @ 60Hz 109.2 mV / kA @ 50 Hz			
Output lead wires	2 x 24 AWG conductors (White/Black), twisted pair, with crimped pins, 600 V, shielded			
Lead length (ft / m)	22 / 7			
Accuracy	0.5% (*)			
Orientation	Arrow points towards Load			
Voltage rating	600 VAC L-N			
Coil Jacket Material	Thermoplastic vulcanizate (TPV), UL 94 V-0 flame rating			
UL compliance	UL 2808, CAN / CSA C22.2 No. 61010-1-12			
Operating temperature	-31 ... +167°F / -35 ... +75°C up to 2000 A -31 ... +140°F / -35 ... +60°C from 2000 A to 4000 A			
Operating altitude	≤ 6560 ft / 2000 m			
Operating humidity	95% RH without condensation			

(*) Following best practices for positional sensitivity and external signal integration.

References

Model	Window (in/mm)	Reference
ROG-80	Ø 3.15 / 80	194S 1080
ROG-120	Ø 4.72 / 120	194S 1120
ROG-200	Ø 7.87 / 200	194S 1200
ROG-300	Ø 11.81 / 300	194S 1300

Your unique solution, your customization

What are the benefits of customizing your current transformers and current sensors?

Perfectly adapted to what you need

Every sector and every application presents specific challenges.

Designed to meet your unique requirements, our extensive range can be tailored to all your configurations and measurement specifications.

Performance optimisation

By tailoring the accuracy and other technical characteristics of your current transformers and current sensors, you can optimise their performance to perfectly meet your specific needs, while maintaining optimal compactness.

Visual consistency with your brand

Customise the colour, marking, and instructions of current sensors to ensure visual consistency with your corporate identity. This ensures an instantly recognisable piece of equipment that enhances your credentials.

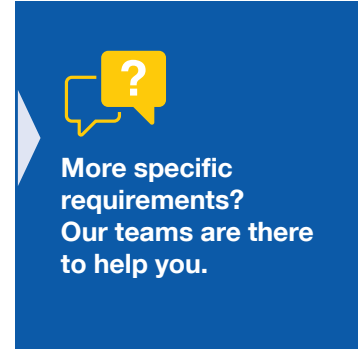

More specific requirements?
Our teams are there to help you.



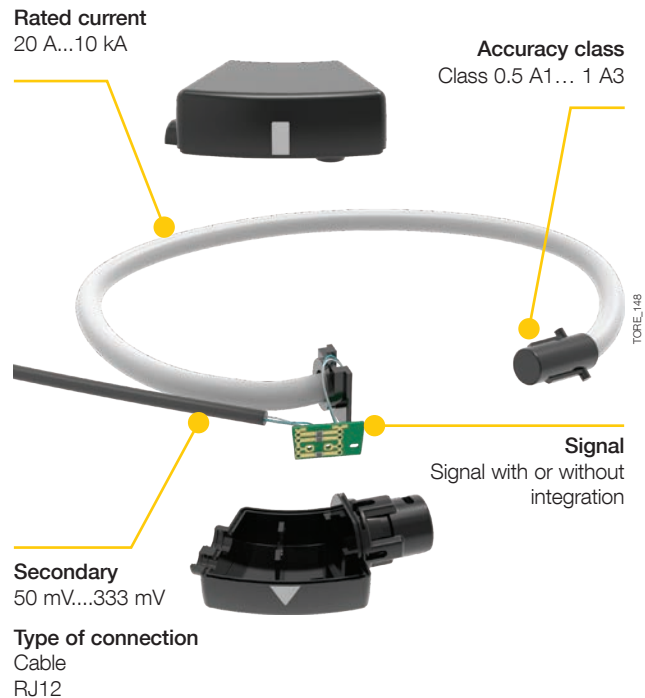
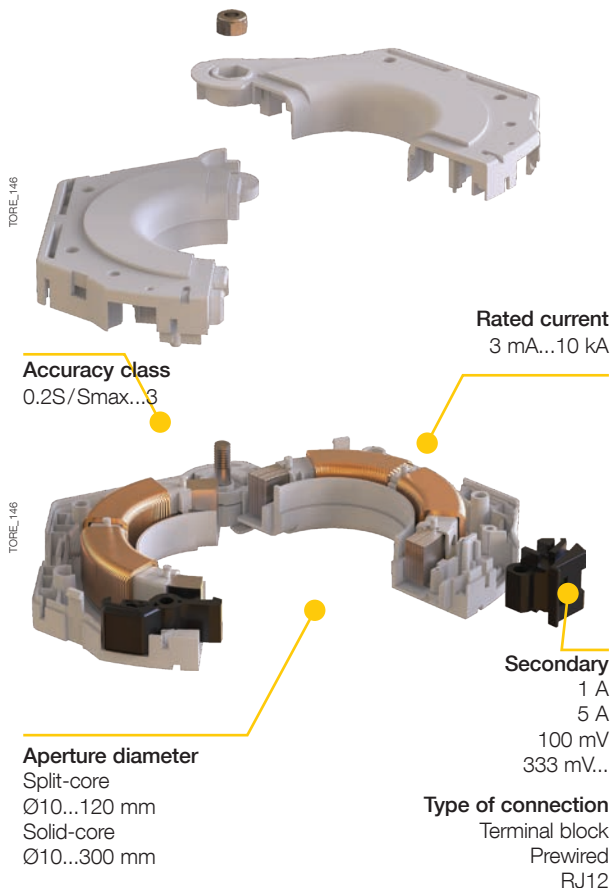









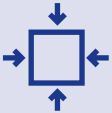

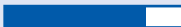

Discover the parameters that you can choose for **ACCULine** current transformers and current sensors:



Find current sensor and current transformer solutions tailor to your project!

Need help in choosing?

Discover the solutions that suit you.

	Function	Current Range	Advantage
MEASUREMENT – METERING	CT-O  <small>GAMME_898</small> <ul style="list-style-type: none"> • Measurement current transformer • Split-core 	Load current range A  >kA	 Compact design
	ROG-O  <small>PAC_003</small> <ul style="list-style-type: none"> • Rogowski measurement sensor • Split-core and flexible 	Load current range A  >kA	 Secure locking
BILLING MEASUREMENT	BCT-C  <small>GAMME_900</small> <ul style="list-style-type: none"> • High-accuracy current transformer for billing • Solid-core 	Load current range A  >kA	 Extensive measurement range
PROTECTION	PCT-C  <small>GAMME_902</small> <ul style="list-style-type: none"> • Protection/measurement current transformer • Solid-core 	Load current range A  >kA	 Extremely robust
RESIDUAL CURRENT DEVICE	DCT-C  <small>TOR_127</small> <ul style="list-style-type: none"> • Residual current transformer • Solid-core 	Load and residual current range mA  kA	 Extensive range
	DCT-O  <small>GAMME_901</small> <ul style="list-style-type: none"> • Residual current transformer • Split-core 	Load and residual current range mA  kA	 Split-core

WEBVIEW

Embedded software for power monitoring and energy management

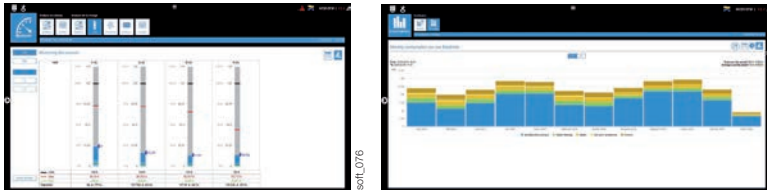

Function

WEBVIEW is a web based software embedded in DIRIS A-40 power monitoring devices, DIRIS Digiware D-70 displays, DIRIS Digiware M-70 communication gateways and DATALOG H80/H81 dataloggers delivering real-time monitoring of all measurements up to 200 devices and displaying the breakdown of energy consumptions.

Uncover the causes of electrical disturbances and anticipate maintenance requirements due to historical records of multiple electrical parameters.

Pre-set alarms defined by the user can be sent by e-mail. Users can access WEBVIEW via a web browser on a PC or a tablet.

Strong points

Plug & Play

Quickly configure WEBVIEW due to the automatic detection of Socomec devices. Create geographical and electrical hierarchies to reflect your installation and your processes.

Easy to use

WEBVIEW centralises measurements from all downstream devices via a single clear and user friendly interface. The ergonomics of each screen allow users to easily and quickly analyze the parameters and the behavior of the installation.

Various functions

Very easy to configure and to use, WEBVIEW offers a wide range of features including real-time monitoring, alarm management and notification by e-mail, multi-utility analysis (electricity, water, gas), power parameter logging and allocation of consumption by end-use and location.

The solution for

- > Industry
- > Building
- > Infrastructure
- > Data center



Strong points

- > Plug & Play
- > Easy to use
- > Various functions

Compliance with standards

- > IEC 62974-1⁽¹⁾



⁽¹⁾ Energy Server standard applicable to WEBVIEW-M and L versions embedded in DIRIS Digiware M-70/D-70 and DATALOG H80.

Characteristics

Type	Hosting	Functions	Number of measurement devices
WEBVIEW-S	DIRIS A-40	Monitor, Alarm, Analyze	1
	DIRIS A-200	Monitor, Alarm, Analyze, Waveform, Photoview, Time of Use	1
WEBVIEW-M	DIRIS Digiware M-70	Monitor, Alarm, Analyse, Photoview	32
	DIRIS Digiware D-70	Monitor, Alarm, Analyse, Photoview	32
WEBVIEW-L	DATALOG H80/H81	Monitor, Alarm, Analyse, Photoview	100/200

Functions

Monitor

- Summary of the parameters measured for the electrical network and loads
- Display of voltage, current, power, power factor, total harmonic distortion (THD) and harmonics per rank
- Display of average/instantaneous values with min/max limits depending on the devices
- Total and partial energy consumption per load
- Input/output status
- Graphical or table representation

Alarm

- Alarms for overloads, events and input status changes
- Display of alarms history
- Sorting by type, nature, criticality or state
- Alarm notification by e-mail (SMTP)

Analyze

- Historical measurements and consumption
- Breakdown of consumption by location, by end-use and by utility type (water, gas, electricity, etc.)
- Export of consumption data in a CSV format

Photoview

- Photoview: customised dashboard of the WEBVIEW environment via the upload of graphical files (building plans, electrical circuit diagrams, production processes, etc.)
- Real time monitoring via drag and drop of parameters on the background pictures (measurement points, alarms, text, etc.)
- Display of the mapping of the measurement plan by cascading of several images



soft_076.eps



soft_074.eps



soft_075.eps



soft_064.eps

References

Type	Host device	Reference
WEBVIEW-S	DIRIS A-40	4825 0501
	DIRIS A-200	4825 0604 / 4825 0605
WEBVIEW-M	DIRIS Digiware M-70	4829 0222
	DIRIS Digiware D-70	4829 0203
WEBVIEW-L 100	DATALOG H80	4854 0020
	DATALOG H81 (3G network)	4854 0021
WEBVIEW-L 200	DATALOG H80	4854 0030
	DATALOG H81 (3G network)	4854 0031



Power Conversion: UPS/STS

Three-phase UPS



MODULYS GP-UL
25 to 100 + 25 kVA/kW
p. 372



MASTERYS BC + 208V
10 to 60 kVA
p. 378

Static transfer power unit



STATYS Integrable
200 A to 1200 A
p. 380

MODULYS GP-UL

Unique, fully modular, and redundant solution
from 25 to 100 + 25 kVA/kW



Applications

- > Data centers
- > Computer rooms
- > Banks
- > Healthcare facilities
- > Insurance
- > Telecom
- > Transport

Strong points

- > Ensures absolute business continuity
- > Aligns capacity to business demand
- > Optimizes costs over the full life cycle

Conformity to standards

- > UL1778
- > CSA C22.2 N. 107.3-05
- > FCC part15 Class A
- > IEC 62040-3 (VFI-SS-111)
- > NEMA 1 (IP20)
- > SEISMIC OSHPD pre-approval (available as option)

Function

With its flexible modularity providing seamless and risk-free power scalability up to 100 + 25 kW, the MODULYS GP-UL range is the ideal solution for unscheduled site upgrades or incremental power evolutions. The installed power can be increased up to 100 + 25 kW by adding hot-swap plug-in power modules for incremental steps of 25 kW.

Designed with no single point of failure, the MODULYS GP-UL offers all the advantages of the Green Power 2.0 technology.

Advantages

Fully modular system

- Plug-in power module.
- Plug-in battery module.
- Plug-in auxiliary mains bypass module.
- Top or bottom connection.
- Top-air exhaust module.

'Forever Young' concept

- Exclusive life cycle extension program.
- Eliminates end-of-life criticality.
- Based on an electronics-free cabinet and a set of plug-in parts.
- Module compatibility guaranteed for 20+ years.
- Allows for the implementation of future module technology.
- Company declaration of 20+ year compatibility.

Totally redundant design

- N+1, N+x redundancy level.
- Designed for no single point of failure.
- No centralized parallel control.
- Totally independent power modules.
- Redundant parallel bus connection (ring configuration).

Enhanced serviceability performance

- Power module automatic firmware alignment.
- Fast & safe maintenance based on hot-swap parts (power modules, auxiliary mains bypass, electronic boards).
- Load fully protected in online double conversion mode (VFI) during power module replacement.
- 3-color LED bar for quick and easy detection of the power module status.
- Battery can be hot-swapped without shutting down the connected equipment.
- Ready for concurrent maintenance.

Standard electrical features

- Dual input mains.
- Backfeed protection: detection circuit.
- EBS (Expert Battery System) for battery management.
- Auto battery test.
- Battery temperature sensor.
- Energy saver mode.

Electrical options

- External battery cabinet.
- High capacity battery charger.
- Internal backfeed isolation device.

Standard communication features

- User-friendly 7" touch-screen multilingual color graphic display.
- 2 slots for communication options.
- USB port to download UPS report and log file.
- Ethernet port for service purpose.
- Commissioning wizard.

Communication options

- Dry-contact interface (configurable voltage-free contacts).
- MODBUS RTU RS485 or MODBUS.
- BACnet/IP interface.
- NET VISION: professional WEB/SNMP Ethernet interface for secure UPS monitoring and remote automatic shutdown

Hybrid bypass architecture

- Distributed Inverter bypasses in parallel to segregated centralized Aux Mains bypass creating a redundant solution.

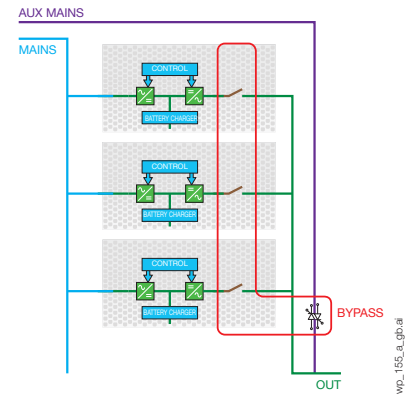

Technical data

UPS model	MODULYS GP-UL						
	Modulys GP-UL 40 KW		Modulys GP-UL 25-100 kW				
Number of power modules	1	2	1	2	3	4	5 ⁽⁵⁾
Power (Sn)	25 kVA	40 kVA	25 kVA	50 kVA	75 kVA	100 kVA	100 kVA (N+1)
Power (Pn)	25 kW	40 kW	25 kW	50 kW	75 kW	100 kW	100 kW (N+1)
Input							
Voltage	480 V 3ph (±15%) up to -40 @ 50% of nominal load		3ph 480 V (±15%) up to -40% @ 50% of nominal load				
Frequency	60 Hz ± 10%						
Input power factor	> 0.99 ⁽¹⁾						
Total harmonic input current distortion (THDi)	< 3% (@: Pn, Resistive load, Mains THDv < 1%)						
Output							
Voltage	400 V 3ph+N		480 V 3ph				
Frequency	60 Hz						
Total output voltage distortion (THDv)	< 1% (@ Pn, Resistive load)						
Overload ⁽²⁾	125% for 10 minutes, 150% for 1 minute						
Crest Factor	> 2.7	> 3.3	> 2.7				> 3.3
Static Bypass⁽³⁾							
Bypass input voltage	rated output voltage ± 15%						
Bypass input frequency	60 Hz ± 2% selectable (±8% if Genset is used)						
Stored energy mode of operation							
Number of battery blocks (VRLA)	from 18+18 to 24+24						
Environment							
Operating temperature	32 to 104 °F ⁽³⁾⁽⁴⁾ / 0 to +40 °C ⁽³⁾⁽⁴⁾						
Storage Temperature	23 to 122 °F / -5 to +50 °C						
Relative humidity	95 % without condensation						
Altitude (max)	3,300 ft (9,840 ft. with derating) / 1,000 m (3,000m with derating)						
Acoustic level at 1 m	< 56 dBA		< 58a dBA				
Required air capacity	470 CFM		1178 CFM				
Dissipated power (max)	3,500 W @ Pn / 11,950 BTU @ Pn		5,200 W @ Pn / 17,750 BTU @ Pn				
Dimensions and weight							
Dimensions (W x D x H)	2' 2" 5/8 x 2' 2" 17/64 x 6' 6" 5/64 676 x 895 x 1983 mm						
Empty cabinet	1,380 lbs / 626 kg		1,043 lbs / 473 kg				
UPS module	75 lbs / 34 kg						
Battery module	220.5 lbs / 100 kg		modular battery cabinet				
Standard							
Safety	UL1778, CSA-C22.2 No. 107.3-05, MET File E114654						
EMC	FCC part 15 Class A						
Performance	IEC 62040-3 (VFI-SS-111)						
Degree of protection standard	NEMA 1 (IP20)						
SEISMIC	OSHDP (available as an option)						

Best practice award



Frost & Sullivan has awarded SOCOMEC with its prize for Innovation & Excellence in Developing Scalable, Best-in-Class Products and Solutions.

SOCOMECS's vast expertise and technological know-how in modular UPS solutions have enabled it to develop a new modular, three-phase UPS that employs the latest cutting-edge technology combined in a unique design and architecture.

Our dedicated Expert Services for UPS

We offer services to ensure your UPS highest availability:

- > Commissioning
- > On-site intervention
- > Preventive maintenance visits
- > Maintenance packages
- > Training
- > Remote monitoring service



www.socomec.com/services

MODULYS GP-UL

Unique, fully modular, and redundant solution
from 25 to 100 + 25 kVA/kW

The benefit of a fully modular system

Easy to manage

- Totally modular system for power scaling or for quickly adapting to business changes.
- Standardized system and modules covering a wide range of power and back-up times.
- Repeatable and standardized scalable architecture for time-saving design for different configuration & architecture requirements.

Pay as you need

- No prior expenditure for unpredictable future extensions in power and back-up time.
- Space saving thanks to reduced footprint and front access.
- Eliminates installation rework costs when new capacity is required from IT physical infrastructure.
- No risk of design oversizing due to project data uncertainty.

Everything front-access

- Connections, switches, manual bypass, auxiliary mains static bypass, power modules and all the electric parts have front-access.
- Total footprint is not increased as rear extra clearance for maintenance is not needed.
- Easy, quick, comfortable, safe and risk-free installation and maintenance.
- More reliable system.

The benefit of totally redundant design

Total resilience

- Electronics-free (failure-free) cabinet.
- Totally independent and self-sufficient modules.
- Real module selective disconnection (automatic inverter bypass with galvanic separation).
- No centralised control for parallel and load sharing management.
- Totally segregated, fully sized and centralised auxiliary mains bypass.
- Configurable N+1 to N+x redundancy (power & battery).
- No single point of failure.
- Redundant parallel bus connection (ring configuration).

Optimum reliability

- Power module designed for superior robustness proved by an independent body (MTBF > 1,000,000 hr).
- Hybrid bypass architecture with distributed module's bypass and centralised mains bypass for ultimate reliability and robustness.
- Highly robust auxiliary mains bypass (MTBF > 10,000,000 hr).
- Acid leak-proof modular battery box.

Cost-effective redundancy

- No need to duplicate the system hardware to get redundancy.
- Redundancy is achievable simply by adding one more power and battery module.
- Redundancy can be easily combined with power scalability.
- Upgrading and/or power module replacement can be done by simple plug-in without any commands to the system.

Maximum availability

- Fast recovery of lost redundancy thanks to minimum MTTR (Mean Time To Repair).
- No risk of downtime during power upgrading and maintenance.
- No risk of failure propagation.

A flexible modular UPS system



View our video
to discover more

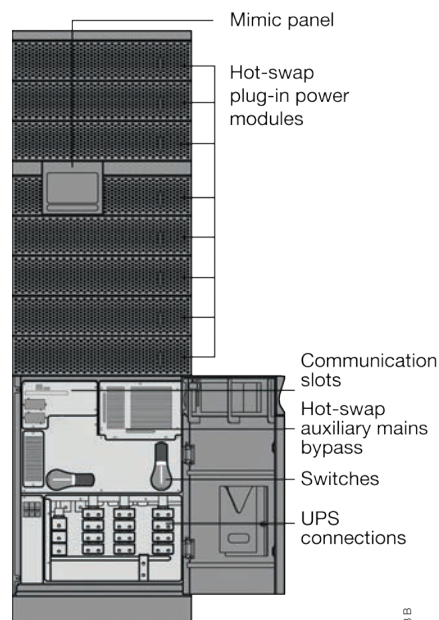

25-200 kW

GREEN 158 B

Seamless and risk-free scalability & upgrading

- MODULYS GP-UL protects critical loads in all conditions, including power upgrading and maintenance procedures.
- No risk of human error and downtime.

On-line power scalability

- MODULYS GP-UL allows you to increase power scalability and redundancy while keeping the load protected on inverter mode simply by plugging-in a new power module and waiting for its automatic self-configuration, without any human intervention.

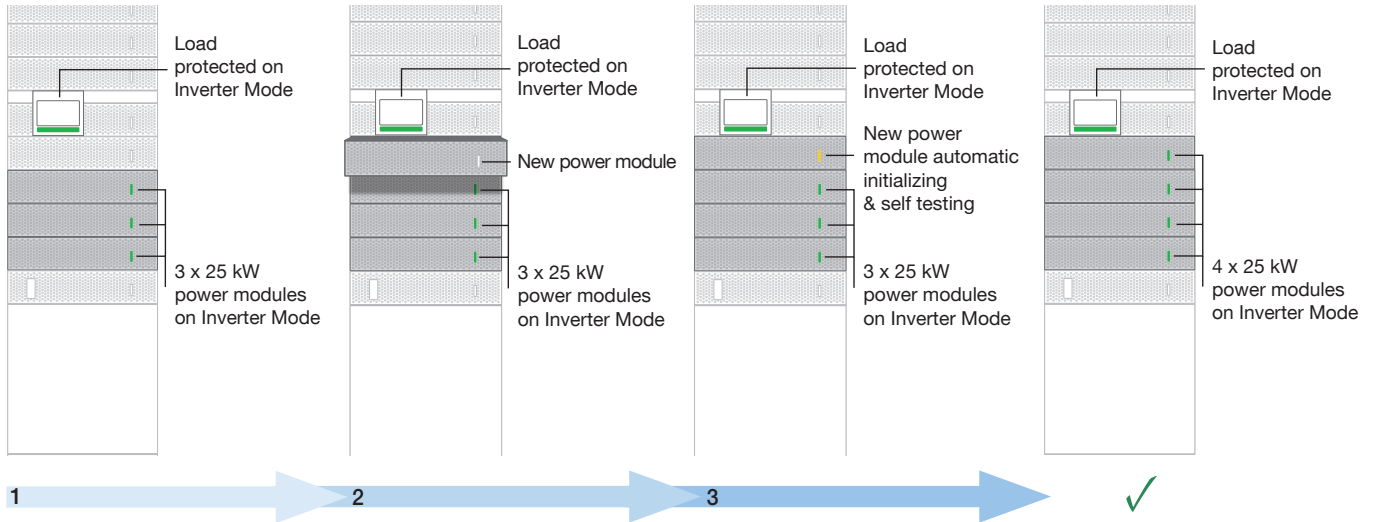

Power module automatic firmware alignment

- Even the power module firmware alignment is totally risk free.
- When a new power module is plugged in, the system checks what firmware version is embedded and if it is different automatically aligns it to one of the other modules. The load is protected at all times while running on inverter mode.

On-line global firmware update

- It is also possible to upgrade the global firmware without switching to bypass to keep the load protected on Inverter mode.
- Automatic procedure for a risk-free firmware upgrade.

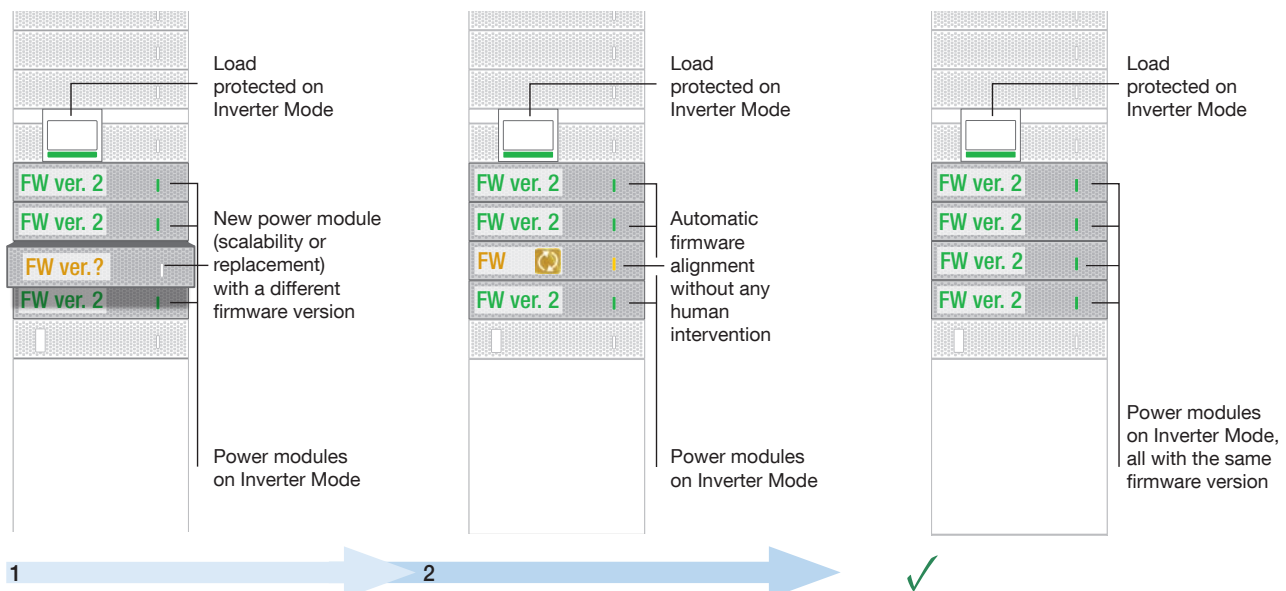

MODULYS GP-UL

Unique, fully modular, and redundant solution
from 25 to 100 + 25 kVA/kW

Flexible and modular back-up times

MODULYS GP-UL offers modular solutions to meet all your requirements for back-up times (whether a few minutes or several hours) without compromising flexibility and scalability.

Internal hot swap battery

- Designed for short back-up time.
- Long-Life batteries available as standard.
- Compact solution with a small footprint.

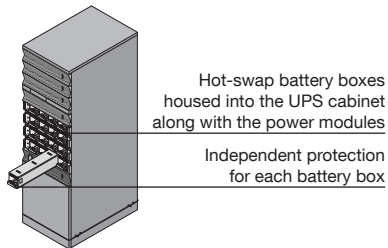

Modular hot-swap battery cabinets

- Designed for medium and long back-up times.
- Long-Life batteries available as standard.
- Vertical and horizontal modularity ensuring flexible back-up times.

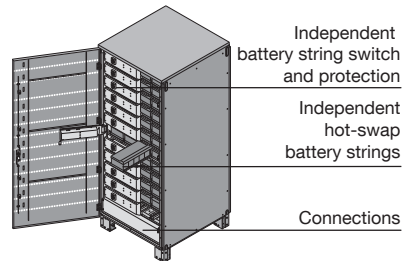

Modular battery cabinet

- Designed for long back-up times.
- Long-Life batteries available as standard.
- Horizontal modularity ensuring flexible back-up times.

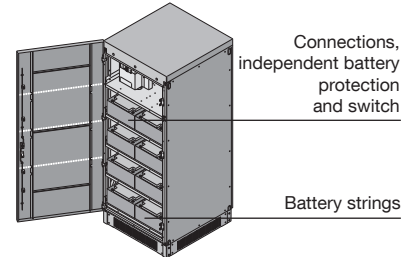

MODULYS GP-UL "Forever Young" concept

- MODULYS GP-UL excels not only in efficiency, flexibility, capacity management and sustainability - five aspects that are crucial for optimum performance.
- It employs an exclusive concept called 'Forever Young' which allows the life-cycle extension of MODULYS GP-UL and eliminates the criticality of system end-of-life.
- It also keeps the system open for the implementation of future technology improvements without modifying the infrastructure.

The 'Forever Young' concept:

- Is based on electronic-free (failure-free) cabinets where the components that are subject to aging are all plug-in and therefore quick and easy to replace.
- Allows life-cycle extension via periodic replacement of power modules before they start aging.
- Provides an always up-to-date system that uses the latest technology.
- Assures power modules and spare part compatibility and availability for more than 20 years.

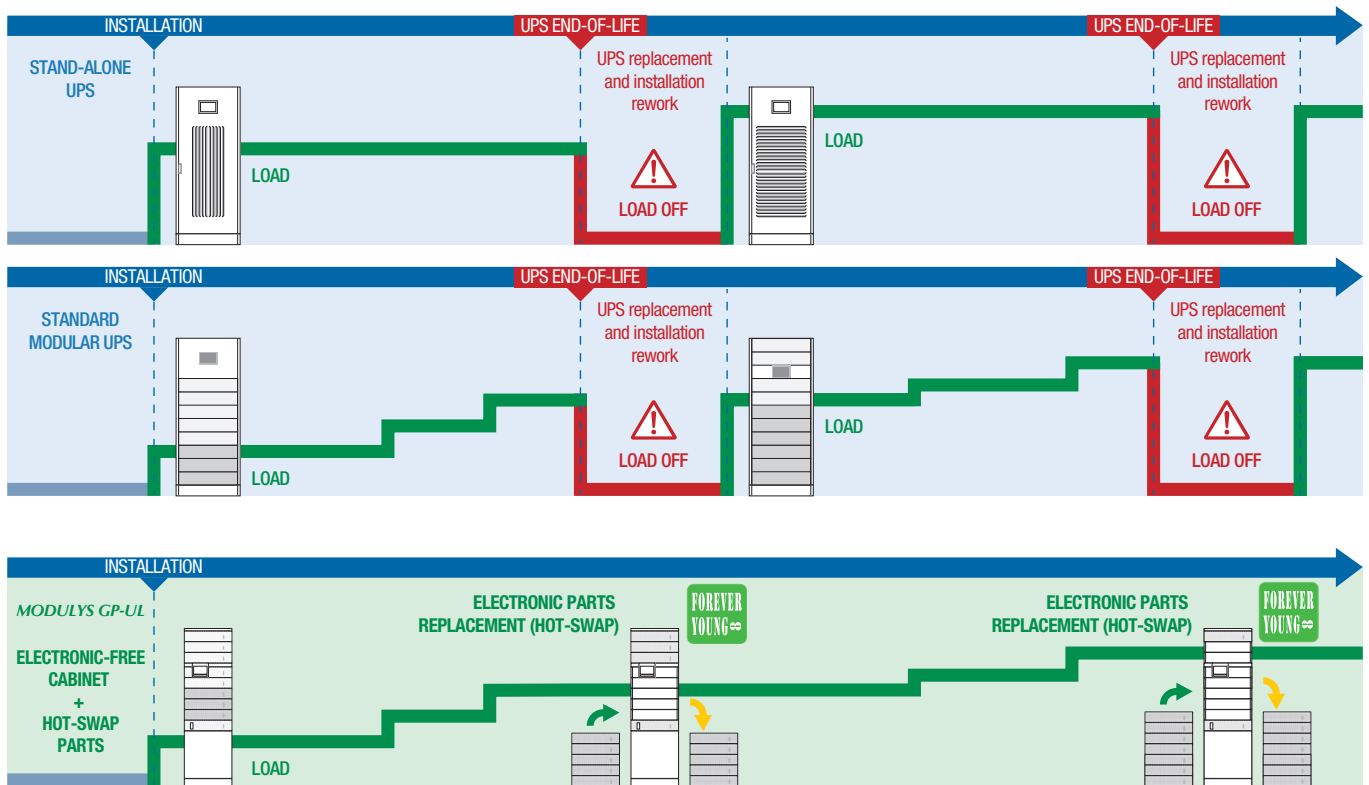

MASTERYS BC+ 208V

Designed for easy integration and use
from 10 to 60kVA



Advantages

A flexible and cost-effective solution

- A compact range of standard product references with a variety of add-on options to adapt to every customer's site.
- Easy to configure for retrofit in existing installations.
- Equipped with either 1 switch or 4 switches for input, output, batteries and bypass mode.

Long back-up time engineered-in

- Several optimised choices for standard internal battery configuration.
- Increased internal battery sensity for reduced footprint and simplified installation.
- Internal basic runtime available up 30 kVA, without additional external battery cabinet.

Embedded digital technology

- Digital Native UPS generation.
- IoT ready device for access to connected services.

Fast and easy installation

- A wide range of UPS from 10 to 60 kVA with the same performance and functionality.
- Quick UPS installation.
- Quickly get online product documentation.

Fast delivery

- North-American stock available for urgent projects or last minute requirements.
- Fast delivery even for customized configurations thanks to easily combined options.

User and environmentally friendly

- 5 languages available in the mimic panel.
- Ergonomics designed to simplify usage.
- Units provided with wheels for easy positioning.

The solution for

- > SME IT networking / computer rooms
- > Banks
- > E-Medical
- > Medical Services
- > Telecom & media infrastructure
- > Transport
- > Control rooms

Certifications

- > UL 1778 5th Edition
- > CSA 22.2 107.3 -05



- > UL 60950-11
- > IEC 62040-1

Advantages



* 40-60kVA

Certifications

We offer services to ensure your UPS highest availability:

- > Commissioning
- > On-site intervention
- > Preventive maintenance visits
- > 24-hour call out and rapid on-site repairs
- > Maintenance packages
- > Training

System features

- Dual input mains
- Internal maintenance bypass switch
- Output switch breaker
- Auxiliary mains switch breaker
- Backfeed protection: detection circuit
- Full compatibility with generators
- Internal long-life batteries up to 30 kVA

Standard communication features

- 5" multilanguage touch screen graphic display
- Serial port RS232
- USB port
- Dry contacts
- Remote Emergency Power Off
- Programmable opto-isolated contacts
- 2 slots for communication options
- Parallel ports (40-60kVA – Cable not included)

System options

- 1 or 4 switches system
- Paralleling kits
- External battery cabinets
- External wrap around bypass
- Temperature sensor for battery cabinet

Communication options

- UTP Ethernet connection - slot-in card
SNMP V3
- 3 input, 8 programmable output card (for
10-30kVA)
- Provides 230V relay contacts + ESD port
- MODBUS / TCP
- BACNET / IP

Technical data

		MASTERYS BC + 208V					
Sn [kVA]		10	20	30	40	50	60
Pn [kW]		9	18	27	40	50	60
Parallel configuration		Up to 6 units			Up to 4 units		
Input							
Rated voltage		208 V 3ph+N					
Voltage tolerance		167 V to 249 V					
Rated frequency		50/60Hz +/- 10%					
Input power factor / THDi		< 3%					
Output							
Rated voltage		208 V / 220 V 3ph+N					
Rated frequency		50 / 60 Hz					
Output voltage distortion (THDv)		< 3%					
Output voltage performance (load variation 0 - 100%)		Complies with IEC 62040-3 Class 1 (VFI-SS-111)					
Inverter overload capability (under rated conditions)		103% continuous / 110% 60 min / 125% 10 min / 150% 1 min					
Bypass overload capability (under rated conditions)		110% continuous / 125% 60 min / 150% 10 min / 200% 1 min					
Efficiency							
Double conversion VFI mode		Up to 95%					
Eco Mode		Up to 98%					
Battery							
Technologies		VRLA AGM/GEL/NiCd					
Configuration		Internal or External			External		
Environmental							
Operating ambient temperature		32 - 104 °F / 0 - 40 °C					
Relative humidity		5-95% without condensing					
Dimensions and Weight							
Dimensions WxDxH		21.7x32.7x59.0" / 550x830x1500mm			23.6x38.6x63.0" / 600x980x1600mm		
Weight		324	324	340	591	613	613
Standard							
Safety - feature		UL 1778 5th Edition CSA C22.2 107.3 -05 and Annex NNN, UL 60950-11, IEC 62040-3					
EMC		FCC Part 15 Subpart J class A					

Dimensions

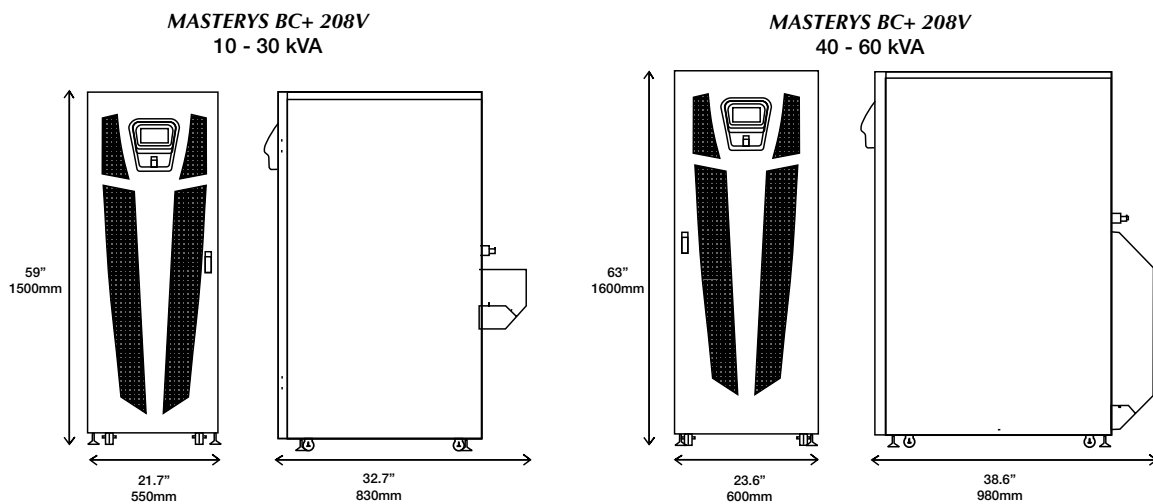

STATYS Integrable

Integrable STS chassis made for Easy and Seamless cabinet integration from 200 A to 1200 A



Function

STATYS Integrable is a fully integrated Static Transfer Power Unit for integration into a cabinet or a power distribution unit (PDU).

Supplied by two independent sources, STATYS Integrable increases the overall electrical infrastructure availability during abnormal events and programmed maintenance.

Advantages

Easy integration

- Pre-engineered mechanical and electrical connections for ease of integration into cabinets or PDUs.
- Installed simply by one operator with no special tools required.
- STATYS Integrable is operated by any HMI via a single connection bus using Modbus protocol.

Unparalleled serviceability

- During preventative maintenance the STATYS Integrable remains fully operational and the load is kept protected.
- STATYS Integrable can be easily integrated or swapped with a new one, without the need of kept specific tools.

Best resiliency

- Full redundant internal design ensuring no single point of failure.
- Internal segregation between critical functions to prevent a fault propagation.
- Load protection ensured even during an internal fault.

Robust design

- Compatible with all types of electrical infrastructure and applications.
- Fully rated SCR ensures no restriction to the continuation of operation.

The solution for

- > Integration in switchboard and PDU
- > Data center
- > Finance, banking and insurance
- > Healthcare sector
- > Telecom & Broadcasting
- > Industry
- > Power generation plants
- > Transport

Advantages



Conformity to standard

- > UL 1008 S recognized File number: E513909
- > IEC 62310-2 (EMC Immunity & Emission)



High reliability - Internal redundant design

Main features:

- Triple redundant power supplies.
- Full redundant DC power bus.
- Redundant microcontroller.
- Redundant SCR drivers.
- Cooling redundancy up to 104 °F/ 40 °C .
- Equipped with an “auto-hold” feature to ensure load continuity in case of internal failure.
- Real-time SCR fault sensing.
- Separation of main functions to prevent internal fault propagation.
- Robust internal field communication bus.
- Internal monitoring of sensors to ensure maximum system reliability.

Hot maintainability

- Fully functional STATYS Integrable during preventive maintenance.
- Hot replacement of the power supplies.
- Hot replacement of fans with no derating.
- Cold swap of the entire STATYS Integrable power unit.

Standard features

- A smart and flexible transfer system that can be configured according to the type of load.
- Synchronized and non-synchronized sources compatibility (configurable synchronization tolerance and switching management).
- Output fault current sensing.
- Full breaker management.
- ATSM (Advanced Transformer Switching Management).
- Available in switched and non-switched neutral.

Standard communication features

- Dry-contact interface (configurable voltage-free contacts).
- Ethernet interface for STATYS Integrable monitoring via WEB pages.
- MODBUS TCP.
- Full digital configuration and setting.
- Single point access for manufacturer HMI.

Communication options

- Additional dry-contact interface. (configurable voltage-free contacts).
- MODBUS RTU RS485.

Technical data

	STATYS INTEGRABLE					
Rating [A]	200	400	600	800	1000	1200
Electrical specifications						
Rated voltage	208-220/380-415/480/600 V					
Voltage tolerance	± 10% (configurable)					
Non-synchronized sources management	configurable up to ±180					
Frequency	50 Hz or 60 Hz ± 5 Hz (configurable)					
Number of phases	3ph+N or 3ph (+ PE)					
Number of poles switching	3 or 4-pole switching			3 pole switching		
Maintenance bypass (cabinet version)	monitoring up to 6 breakers					
Overload	150% for 2 minutes - 110% for 60 minutes					
Efficiency	99%					
Admissible power factor	no restrictions					
Environment						
Operating ambient temperature	32-104 °F / 0-40 °C					
Relative humidity	95%					
Maximum altitude	3280 ft / 1000 m a.s.l. without derating					
Acoustic level at 3.28 ft / 1m (ISO 3746)	≤ 60 dBA					
Standards						
Safety	UL 1008 S					
EMC	C2 category IEC 62310-2, FCC part 15					



Pre-engineered solution for easy integration into the cabinet.

APPL_1002



Energy Storage Solutions

Outdoor Energy Storage



SUNSYS HES L

From 50 kVA / 203 kWh to 550 kVA / 1218 kWh
p. 384



SUNSYS HES XXL

From 1 MVA / 2 MWh to 6 MVA / 23 MWh
p. 388



SUNSYS HES L[©]

Modular outdoor energy storage system

from 50 kVA / 203 kWh to 550 kVA / 1218 kWh



SUNSYS-HES-L-EO-ENG

Function

SUNSYS HES L is a modular outdoor energy storage system designed for both on-grid and off-grid applications. It is available in a variety of configurations, to provide the ideal system size for a range of project requirements.

It supports dedicated applications such as optimization of photovoltaics with self consumption, peak shaving, backup power, and EV charging infrastructure support.

SUNSYS HES L combines the economic returns of on-grid operation with the security of a microgrid when the grid may fail.

Advantages

High safety standards

SUNSYS HES L integrates advanced power conversion and LFP battery technologies to create a winning formula.

The B-Cab L (Battery Cabinet) uses liquidcooled thermal management, with an integrated fire safety system, and meets the requirements of the latest international fire code.

The complete system is certified to the latest UL 9540, the safety standard for energy storage systems in both the Canada and the USA.

Extreme modularity

SUNSYS HES L is a modular energy storage system that uses 2 standard cabinets to enable 29 UL certified configurations, providing ideal system sizing for a variety of projects.

- C-Cab L: Converter Cabinet from 50 to 300 kVA per Cabinet.
- B-Cab L: Battery Cabinet of 203 kWh.

2 C-Cabs L can be stacked in parallel with up to 6 B-Cabs L reaching a maximum configuration of 550 kVA / 1218 kWh.

Standard configurations simplify the design, quotation, installation and commissioning process of your projects.

Fully bankable historical supplier

Socomec is a 100+ years old company with expert knowledge in power conversion, switching and monitoring.

With our energy storage experience of 10+ years and 420+ systems installed worldwide, we have proven our knowledge and support process on the field.

Integrated ready-to-use certified system

SUNSYS HES L systems, including inverter, batteries and control components, are fully integrated, tested and certified.

Our systems have undergone a typetesting procedure to guarantee reliable behavior and performance, reducing the time and effort required for commissioning. Specially adapted software for internal communication between all cabinets has been developed allowing efficient monitoring and control of the system, called PMS. Going a step further, we enabled thanks to SunSpec standard an easy integration with external EMS if you require it.

Whether you have a switchboard, solar system, generators or other equipment on site, our systems are designed to be compatible with a wide range of existing installations.

The solution for

- > Commercial and industrial buildings
- > EV charging infrastructure
- > Isolated microgrids
- > Resilient microgrids
- > Renewable energy integration

Strong Points

- > High safety standards
- > Extreme modularity
- > Fully bankable historical supplier
- > Integrated ready to use certified system

Conformity to standards

- > **Safety:** UL 9540; UL 9540A; UL 1973; NFPA 855; NFPA 68
- > **EMC:** FCC part 15 Level A
- > **Environment:** RoHS; REACH, IEC 61249
- > **Communication protocol:** Modbus TCP; SunSpec 2.0
- > **Grid code:** UL 1741 SB; UL 1741 PCS CRD; IEEE 1547-2018; IEEE 1547.1-2020; CA Rule 21
- > CEC listed

Please consult us for additional ones.

Expert Services

An experienced and skilled team is at your service to make your project a success!

- > **Project development:** pre-sales support, project design
- > **Deployment:** training, field inspection, pre-commissioning, commissioning
- > **Operation:** maintenance contracts, spare parts replacement, remote monitoring
- > Cloud data storage
- > Extended warranty on both product and performance

For more information, please contact us.

Suitable for all of the following applications

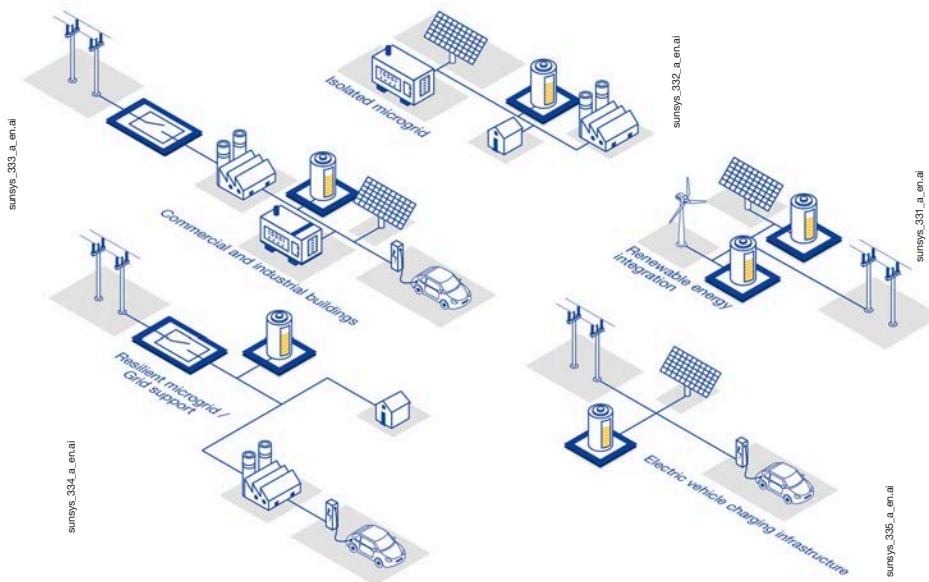

Native services supported by SUNSYS HES L

- > Demand charge reduction
- > Peak shaving
- > Time-of-Use
- > Energy arbitrage
- > Energy smoothing
- > Energy shifting
- > Emergency back-up
- > PV self-consumption
- > Compatible with external EMS to unlock more services

Modular Design enables Variety without Complexity



(W x D x H): 1000 x 1300 x 2160 mm
39.4 x 51.2 x 85 in
Up to 1085 kg / 2392 lbs



(W x D x H): 1390 x 1344 x 2348 mm
54.7 x 52.9 x 92.4 in
2370 kg / 5225 lbs

C-Cab L - Converter Cabinet

- > Bidirectional hot swappable power converter
- > 50 to 300 kVA / cabinet
- > Automation functions and EMS connection
- > AC/DC distribution and protection
- > Battery management system
- > IoT Ready

B-Cab L - Battery Cabinet

- > Lithium Iron Phosphate (LFP) Chemistry
- > 203 kWh / rack
- > Liquid cooling thermal management
- > Integrated fire safety detection and suppression system
- > Life cycle of 8000 cycles at 25°C; 0.5P

SUNSYS HES L[®]

Modular outdoor energy storage system

from 50 kVA / 203 kWh to 550 kVA / 1218 kWh

Many system configurations are available to meet customer requirements

		1 Rack	2 Racks	3 Racks	4 Racks	5 Racks	6 Racks
		203 kWh	406 kWh	609 kWh	812 kWh	1,015 kWh	1,218 kWh
C-Cab 1	50	3.4					
	100	2.0	3.4	5.2			
	150		2.2	3.4	4.6		
	200		2.0	2.5	3.4	4.3	
	250			2.0	2.7	3.4	4.1
	300			2.0	2.2	2.8	3.4
C-Cab 2	350				2.0	2.4	2.9
	400				2.0	2.1	2.5
	450					2.0	2.2
	500						2.0
	550						2.0

Duration shown in AC useable energy at BOL

(*) Power derating to respect 0.5 P-Rate

Remote Monitoring & Debugging

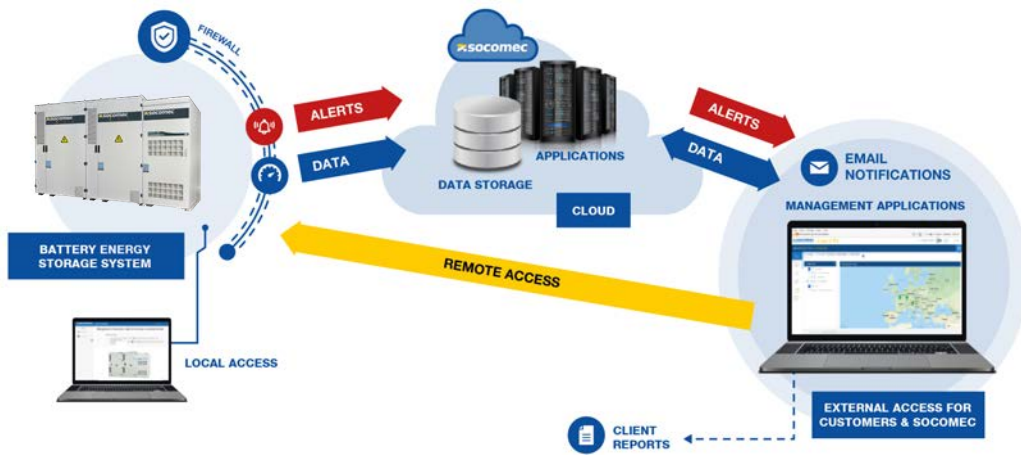

Local management

The Socomec Power Management System, coordinating the operation of all converter and battery components. It's capabilities include: This open platform, integrated in the C-Cab, provides access to:

- Peak shaving, energy shifting, self-consumption and fuel saving to maximise valuable savings,
- Transitions between on-grid and microgrid operation,
- Autonomous microgrid management,
- Compatibility with 3rd party energy management software suites, through a Sunspec 2.0 or Modbus interface,
- SCADA integration through Modbus/TCP.

Remote monitoring

In addition, the C-Cab L also integrates IoT devices that make it possible to continuously monitor the system remotely.

These devices enable the following, through 2 offers SoLive and SoLive Pro:

- Web dashboard for on-line monitoring,
- Web access to the system KPIs,
- Smartphone app,
- Remote firmware upgrade.

Technical Data

System information											
Power modularity	50 kVA power modules - up to 550 kVA										
Symmetrical overload	110% during 60 min - 125% during 20 min - 150% during 60 sec										
Chemistry	LFP - Lithium Iron Phosphate										
Energy Nameplate	203.7 kWh per rack										
AC/AC Max Round Trip Efficiency	90%										
Maximum P-rate	0.5 P										
Maximum DC current	82 A charging / 87 A discharging per 50 kVA power module										
Power rating	50 kVA	100 kVA	150 kVA	200 kVA	250 kVA	300 kVA	350 kVA	400 kVA	450 kVA	500 kVA	550 kVA
AC rated current	60 A	120 A	180 A	241 A	301 A	361 A	421 A	481 A	541 A	602 A	662 A
AC max. temporary current (overload)	90 A	180 A	271 A	361 A	451 A	541 A	631 A	721 A	811 A	902 A	992 A
AC connections	Up to 4x95mm ² /3/0AWG - 3x150mm ² /300MCM - 2x185mm ² /350MCM										
Rated voltage (Un)	480 Vac (3ph+N) ±20%										
Rated frequency	60 Hz ±5%										
Fire protection	Fire Safety System including smoke detectors, heat detectors, aerosol and deflagration venting panel										
Environment											
Degree of protection	IP 55 / NEMA 3R (Outdoor)										
Operation temperature	-20 °C to +45 °C / -4 °F to +113 °F without derating - up to +50 °C / 122°F with derating										
Storage temperature	-20 °C to +60 °C / -4 °F to +140°F										
Acoustic level at 1 m	< 64.8 dB										
Maximum altitude	1000 m / 3280 ft. without derating (consult us for requirements above this)										

Two system installation options according to the space available on your site

In-line installation (with 1 C-Cab L)

Up to 6 B-Cabs L - dimensions (mm/in)

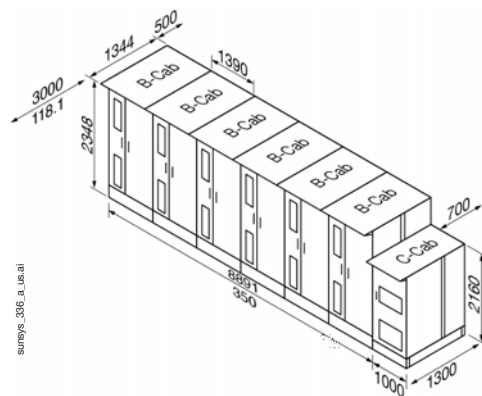

Back-to-back installation (with 1 C-Cab L)

Up to 6 B-Cabs L - dimensions (mm/in)

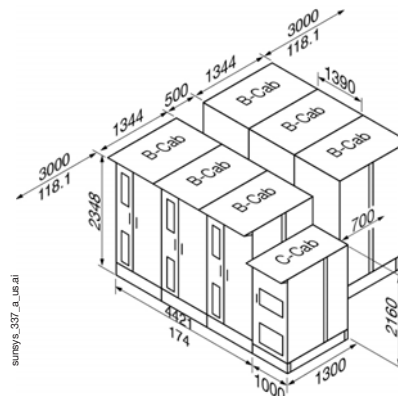

Also available



SUNSYS-HES-xxl-1c-1b-EO-.png

SUNSYS HES XXL[®]
High power energy storage system
from 0.5 MVA / 1.6 MWh to 6 MVA / 24 MWh

SUNSYS HES XXL[®]

High power energy storage system

from 0.5 MVA / 1.6 MWh to 6 MVA / 24 MWh

SUNSYS HES XXL



Function

SUNSYS HES XXL is an outdoor high power energy storage system designed for both on-grid and off-grid applications. It is available in a variety of configurations, to provide the ideal system size for a range of project requirements. It supports dedicated applications such as optimization of photovoltaics with self consumption, peak shaving, backup power, and EV charging infrastructure support. SUNSYS HES XXL combines the economic returns of on-grid operation with the security of a microgrid when the grid may fail.

It is perfectly adapted to large scale commercial and industrial installations as well as front of the meter projects.

Advantages

High safety

SUNSYS HES XXL integrates advanced power conversion and LFP battery technologies to create a winning formula. The B-Cab XXL (Battery Cabinet) uses liquid-cooled thermal management, with an integrated fire safety system, and meets the requirements of the latest international fire code.

The complete system is certified to the latest UL 9540, the safety standard for energy storage systems in both Canada and the USA.

Extreme scalability

Large variety of system configurations are available based on three standard cabinets:

- C-Cab XXL: Converter Cabinet from 0.5 to 1.5 MVA
- B-Cab XXL: Battery Cabinet of 407kWh
- M-Cab XXL: Master Control Cabinet embedding smart components

While putting up to 4 systems in parallel it is possible to reach 6 MVA / 24 MWh.

Fully bankable supplier

Socomec is a 100+ years old company with expert knowledge in power conversion, switching and monitoring.

With our energy storage experience of 10+ years and 420+ systems installed worldwide, we have proven our knowledge and support process on the field.

Integrated ready to use certified system

SUNSYS HES XXL systems, including inverter, batteries and control cabinets, are certified and tested. Our systems have undergone a type-testing procedure to guarantee reliable behavior and performance, reducing the time and effort required for commissioning.

Specially adapted software for internal communication between all cabinets has been developed allowing efficient monitoring and control of the system, called PMS. Going a step further, we enabled thanks to SunSpec standard an easy integration with external EMS if you require it.

Whether you have a switchboard, solar system, generators or other equipment on site, our systems are designed to be compatible with a wide range of existing installations.

The solution for

- > Large commercial and industrial buildings
- > EV charging infrastructures
- > Grid support
- > Isolated microgrids
- > Resilient microgrids
- > Community solar

Strong Points

- > High safety
- > Extreme scalability
- > Fully bankable historical supplier
- > Integrated ready to use certified system

Conformity to standards

- > **Safety:** UL 9540; UL 9540A; UL 1973; NFPA 855; NFPA 68
- > **EMC:** FCC part 15 Level A
- > **Environment:** RoHS; REACH IEC 61249
- > **Communication protocol:** Modbus TCP; SunSpec 2.0
- > **Grid code:** UL 1741 SB; UL 3141; IEEE 1547-2018; IEEE 1547.1-2020; CA Rule 21
- > CEC listed

Please consult us for additional ones.

Expert Services

An experienced and skilled team is at your service to make your project a success, providing optimized asset management and performance!

- > **Project development:** pre-sales support, project design
- > **Deployment:** training, field inspection, commissioning
- > **Operation:** maintenance contracts, spare parts replacement, remote monitoring
- > Cloud data storage
- > Extended product and performance warranties

For more information, please contact us.

Suitable for all of the following applications

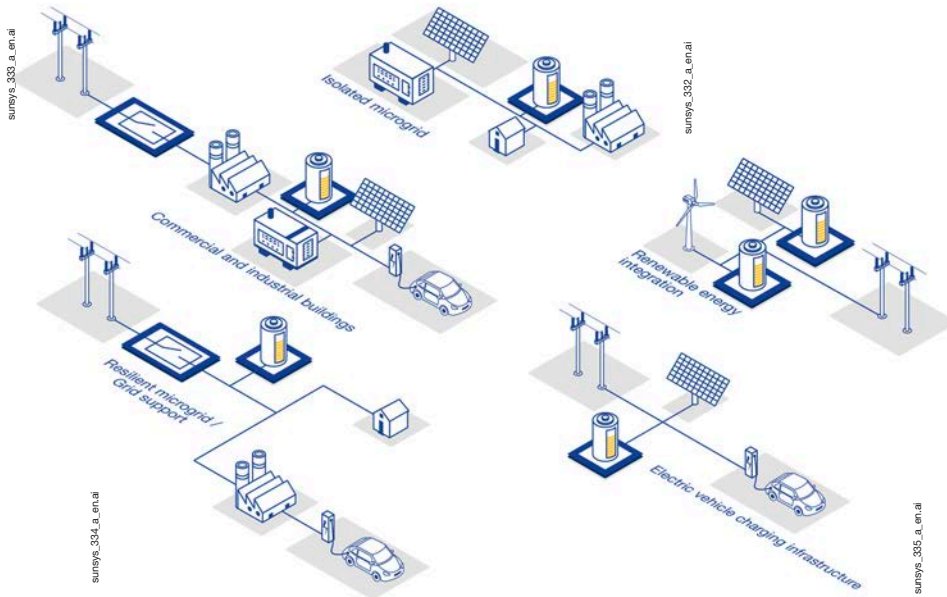

Native services supported by SUNSYS HES XXL

- > Demand charge reduction
- > Peak shaving
- > Time-of-Use
- > Energy arbitrage
- > Energy smoothing
- > Energy shifting
- > Capacity reserve
- > Frequency regulation
- > Voltage control
- > Emergency back-up
- > PV self-consumption
- > Compatible with external EMS to unlock more services

3 modular units for maximum flexibility



C-Cab XXL Converter Cabinet

- > Bidirectional power converter
- > 0.5 to 1.5 MVA / cabinet
- > Hybrid liquid / air cooling system
- > On and off-grid operation

B-Cab XXL Battery Cabinet

- > Lithium Iron Phosphate (LFP) Chemistry
- > 407 kWh / rack
- > Liquid cooling thermal management
- > Integrated fire safety detection and suppression system
- > Life cycle of 8000 cycles at 25°C; 0.5P

M-Cab XXL Master Cabinet

- > ESS control cabinet
- > Integrated battery management system
- > Remote management
- > Auxiliaries power supply
- > Automation functions and EMS connection
- > Battery data logging

SUNSYS HES XXL[®]

High power energy storage system

from 0.5 MVA / 1.6 MWh to 6 MVA / 24 MWh

Many system configurations are available to meet customer requirements

1 C-Cab XXL - 600 or 690 V

	4 Racks	5 Racks	6 Racks	7 Racks	8 Racks	9 Racks	10 Racks	11 Racks	12 Racks	13 Racks	14 Racks	15 Racks
	1,628 kWh	2,035 kWh	2,442 kWh	2,849 kWh	3,256 kWh	3,663 kWh	4,070 kWh	4,477 kWh	4,884 kWh	5,291 kWh	5,698 kWh	6,105 kWh
500 kVA	3.0	3.8	4.5									
750 kVA	2.0	2.5	3.0	3.5	4.1							
1,000 kVA		2.0	2.3	2.6	3.0	3.4	3.8	4.2				
1,250 kVA			2.0	2.1	2.4	2.7	3.0	3.3	3.6	3.9	4.3	
1,500 kVA				2.0	2.0	2.3	2.5	2.8	3.0	3.3	3.5	3.8

Duration shown in AC useable energy at BOL
Power derating to respect 0.5 CP

i Parallel up to 4 SUNSYS HES XXL[®]

Thanks to the scalable architecture of SUNSYS HES XXL, you can add up to 4 systems in parallel and reach a max power of 6 MVA / 24 MWh. Ask us for more details.

Remote Monitoring & Debugging

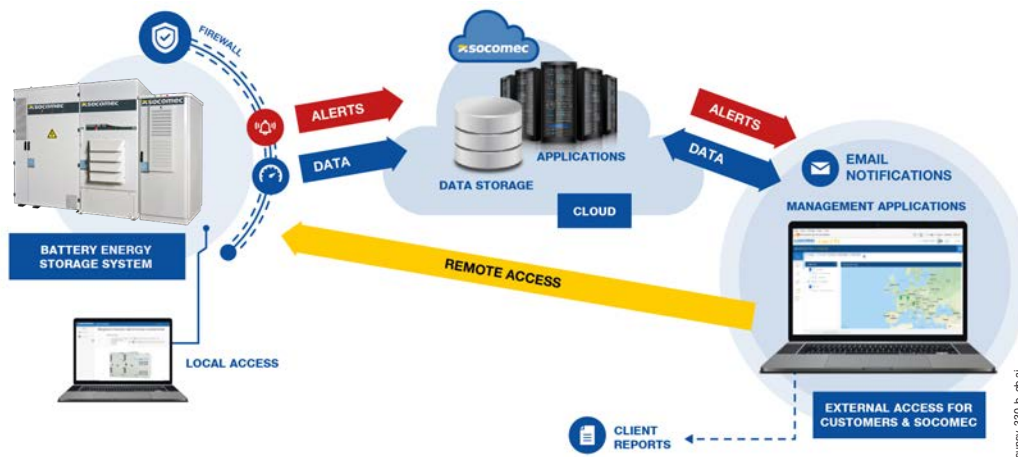

Local management

The Socomec Power Management System, coordinating the operation of all converter and battery components. Its capabilities include:

This open platform, integrated in the M-Cab XXL, provides access to:

- Peak shaving, energy shifting, self-consumption and fuel saving to maximise valuable savings,
- Transitions between on-grid and microgrid operation,
- Autonomous microgrid management,
- Compatibility with 3rd party energy management software suites, through a Sunspec 2.0 or Modbus interface,
- SCADA integration through Modbus/TCP.

Remote monitoring

In addition, the M-Cab XXL also integrates IoT devices that make it possible to continuously monitor the system remotely.

These devices enable the following, through 2 offers SoLive and SoLive Pro:

- Web dashboard for on-line monitoring,
- Web access to the system KPIs,
- Smartphone app,
- Remote firmware upgrade.

SUNSYS HES XXL system architectures

Architecture with 1 C-Cab XXL

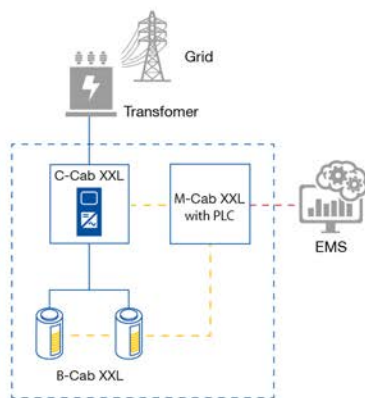

Architecture with multiple C-Cabs XXL

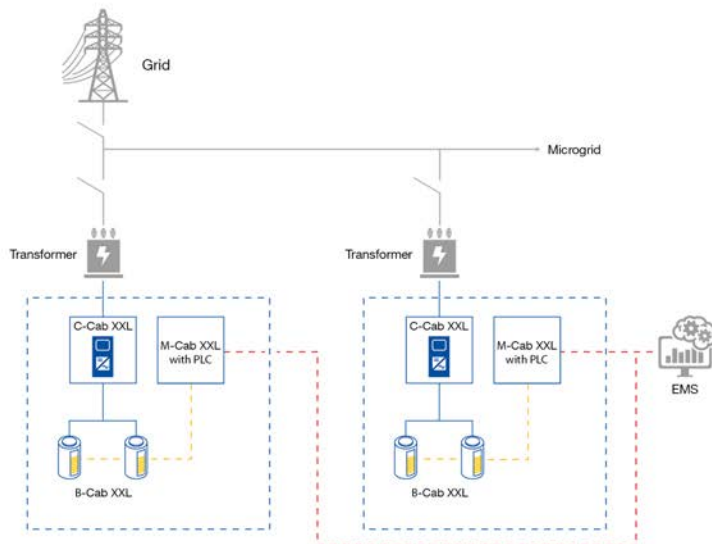

— Power connection - - - - - Power management by PLC - - - - - Connecting to external EMS - - - - - Provided by Socomec

Technical Data

System information

Power modularity	0.5 MVA & 1 MVA & 1.25 MVA @ 600 Vac or 1.5 MVA @ 690 Vac per C-Cab XXL
Chemistry	LFP - Lithium Iron Phosphate
Energy Nameplate	407.3 kWh per cabinet
AC/AC Max Round Trip Efficiency	higher than 90%*
Maximum P-rate	0.5 P
AC connections	3-wire (3P3W) 16 x 600 kcmil or 6 x 300 mm ²
AC Voltage range	600-690 VRMS +/-10%
Rated frequency	50 & 60 Hz configurable
Fire protection	fire safety system including smoke detectors, heat detectors, aerosol, dry pipe and deflagration venting panel

Environment

Environment installation	Outdoor
Degree of protection	IP 55
Operation temperature	-20 to 45 C° -4 to +113°F without derating
Acoustic level at 3 m	< 75 dBA @ 3m
Altitude max.	1,000 m / 3,280 ft without derating (above 1,000 m / 3,280 ft, 10% per 1,000 m / 3,280 ft)

*Energy consumption of the auxiliaries is not taken into account

Also available



SUNSYS-HES-L-EO-1.png

SUNSYS HES L[®]

Modular Outdoor Energy Storage System
from 50 kVA / 203 kWh to 550 kVA / 1,218 kWh systems







Expert services

Services for Uninterruptible Power Supply and Static Transfer System.....	p. 396
Service for Switching Equipment.....	p. 414
Service for Power Monitoring and Measurement.....	p. 420
Service for Energy Storage Systems.....	p. 426
Power testing & Certification - Tesla Lab.....	p. 434





Expert Services Selection Guide

Ensuring the energy performance of electrical installations, wherever it is critical p. 4
 Your energy, our expertise p. 6
 Your partner in expert services p. 8

Uninterruptible Power Supply (UPS) and Static Transfer System (STS)	
	
MODULYS Three-phase UPS	STATYS Static Transfer Switch

Commissioning	On-site commissioning		p. 398				p. 399			
	Remote commissioning		p. 398				p. 399			
Maintenance contracts	Type of contract	p. 400	Silver	Gold	Platinum	Platinum +	Silver	Gold	Platinum	Platinum +
Services for maintenance contracts	Preventive maintenance visit	p. 402	Included 1/year				Included 1/year			
	Emergency service 24/7	p. 403	○	○	○	●	○	○	○	●
	SoLink 24/7 remote monitoring	p. 404	○	○	○	○				
	Remote troubleshooting**	p. 406	○	○	○	○				
	Consumables replacement	p. 407	○	○	○	○	○	○	○	○
	Battery care	p. 408	○	○	○	○				
Battery replacement	p. 410	○	○	○	○					
Single services	Inspection visit	p. 419								
Energy storage system services	Preventive maintenance	p. 428								
	Extended warranty	p. 430								
Customer training	On-site (Socomec or customer's site)	p. 412		○				○		
Professional services	Tesla Lab	p. 434								

● : included.
 ○ : optional.
 ◉ : service coverage in your area.
 **Contact us to find out which UPS ranges and models are compatible with this service.

					Switching equipment	Power monitoring and measurement	Energy storage system	
								
					ATyS	DIRIS DIRIS Digiware	WEBVIEW-L	SUNSYS HES L
					Automatic Transfer Switch	Energy meter, multi-function meter and power metering system	Power monitoring software	Energy storage system
					•	•	•	
					Silver	Gold	Platinum	Platinum +
					Included 1/year			
					○	○	○	●
					○			
								○
								○
						○	○	○



1

2

3

MODULYS XI

Services for Uninterruptible Power Supply and Static Transfer System

Commissioning

Three-phase UPS	p. 398
STATYS Static Transfer System (STS)	p. 399

Maintenance contracts

Three-phase UPS	p. 400
STATYS Static Transfer System (STS)	p. 401

Optional services for maintenance contracts

Preventive maintenance visit	p. 402
Emergency service 24/7	p. 403
SoLink - Socomec experts 24/7 UPS remote monitoring	p. 404
Remote troubleshooting problem solving securely and instantly	p. 406
Consumable replacement	p. 407
Battery care	p. 408
Battery replacement	p. 410

Customer training

Certified manufacturer's training programme for UPS and STS	p. 412
---	--------



Commissioning

Three-phase Uninterruptible Power Supply (UPS)



The commissioning of a UPS covers start-up of the equipment, verification of its functions according to its design specifications, and to ensure that it is compatible with the customer's working environment.

Socomec performs the commissioning service within a quality process standard by ensuring that your equipment will be delivered in a safe, reliable and operational condition.

socomec
Innovative Power Solutions

PLACE YOUR CERTIFICATION HERE

CERTIFICATION OF "SAFE AND RELIABLE INSTALLATION"

TECHNICAL SUPPORT: _____

HOT LINE: _____

CONTRACT No: _____

UPS TYPE	_____
POWER	_____
SERIAL NUMBER	_____
CONFIGURATION (single/parallel)	_____
COMMISSIONING DATE (UPS)	_____
COMMISSIONING DATE (Battery)	_____
VALIDITY OF THE CERTIFICATE (check renewal)	_____

SOCOMECC (www.socomec.com) declares the system has been checked and certified for high quality and availability supply and reserves the right to limit the responsibility in case the start up and the maintenance is not performed by authorised personnel*. The present certificate should be renewed on yearly basis.

* Personnel is authorised only if trained by the manufacturer and enabled by a certificate released by the manufacturer. Only authorised personnel can insure Competence, Original spare parts, global diagnostic through appropriate tools, Update of the unit according to new releases.

Key points

- > Work environment inspection
- > Electrical installation check (isolator switch, cabling, circuit breakers etc.)
- > UPS internal and external check
- > System power on and set up
- > Operating test on single UPS and/or parallel system
- > Load bank test (on request)

Benefits

- > Compliance with the various installation standards
- > Completes the Factory Acceptance Test
- > Commissioning traceability
- > Conformity certificate

Commissioning

for STATYS Static Transfer System (STS)



The commissioning of an STS covers start-up of the equipment, verification of its functions according to its design specifications, and to ensure that it is compatible with the customer's working environment.

SOCOMEc performs the commissioning service within a quality process standard by ensuring that your equipment will be delivered in a safe, reliable and operational condition.

Key points

- > Work environment inspection
- > Electrical installation check
- > STS internal and external check
- > System power on and set up
- > Ventilation check
- > Operating test

Benefits

- > Commissioning performed in compliance with applicable quality and safety standards
- > Compatibility with your work environment
- > Compliance with the various installation standards
- > Conformity certificate

Maintenance contracts

Three-phase UPS



Our service contracts are tailored to customer needs, taking into account individual operational constraints, business processes and the unique level of criticality associated with specific applications. Whatever the issue, our internal escalation process from local specialist support teams up to corporate R&D and expert engineering teams, gives us access to different levels of expertise to respond as quickly as possible. Our service teams are trained and equipped with certified equipment to provide the highest levels of expertise.

Key points

- > Original spare parts
- > Expert engineers equipped with professional tools and software
- > Safety procedures
- > Access to different levels of expertise in order to respond as quickly as possible
- > Native cyber-secure cloud services

SERVICE DESCRIPTION	SILVER	GOLD	PLATINUM
Annual preventive maintenance visit ⁽¹⁾	•	•	•
Hotline 8x5 + response to site by next working day	•	•	•
Hotline 24x7 + response to site in 6 hours	○	○	○
Labour from Socomec specialist (onsite & remote)		•	•
Original spare parts			•
Ready-to-use spare power brick/module onsite	○	○	○
Native cyber-secure cloud services ⁽²⁾			•
<ul style="list-style-type: none"> • SoLive monitoring application • Remote cloud surveillance 24x7 • Access to log interactive web dashboard • Annual Health Check report • Proactive alarm management • Remote response and diagnosis within 2 hours • Remote troubleshooting⁽³⁾ 	•	•	•

•: included.

○: optional.

⁽¹⁾ Remote preventive visits are possible with certain UPS models. Contact us for more information.

⁽²⁾ Available for UPS equipped with a Net Vision network card and connected to Socomec's cloud.

⁽³⁾ Upon end-user confirmation, a Socomec specialist will be available to activate a direct-to-machine temporary remote connection in order to perform an in-depth diagnosis and carry out troubleshooting where possible. This service is available for certain UPS models. Contact us for more information.

Benefits

- > Minimum downtime and extended lifespan
- > Maximum peace of mind
- > Precise budget control

Maintenance contracts

for STATYS Static Transfer System (STS)



Silver, Gold, Platinum and Platinum+ are the Maintenance service contracts suitable for standard STS.

50+ years of manufacturer's experience is at your disposal to provide you with a comprehensive support package which affords you complete peace of mind.

SERVICE DESCRIPTION	SILVER	GOLD	PLATINUM
1 Annual preventive maintenance visit	•	•	•
Labour & Mileage for corrective maintenance		•	•
Original spare parts			•
Hot-line availability	•	•	•
Emergency hot-line 24/7	○	○	○
Response time to site within next working day	•	•	•
Response time to site within 6h*	○	○	○
Response time to site within 4h*	○	○	○
Preventive replacement of consumables (fans and capacitors)	○	○	○
Additional preventive maintenance visit	○	○	○
Out of hours preventive maintenance visit during night, week-end, bank holidays	○	○	○
Thermal imaging	○	○	○

•: included.

○: optional.

* Please check the service coverage in your area.

Key points

- > Original spare parts
- > Expert engineers equipped with professional tools and software
- > Safety procedures

Benefits

- > Improves system availability
- > Optimises product lifespan
- > On-site interventions guaranteed

Optional services for maintenance contract

Preventative maintenance visit



The service life of equipment depends on the operating environment (temperature, humidity, dust). To keep equipment running at maximum levels of efficiency and to avoid system downtime with possible risks and damage to loads, it is important to have the manufacturer's expertise to perform regular preventive maintenance.

This is the best way to ensure the reliability of your equipment over time and the most cost-effective solution to keep the Total Cost of Ownership under control.

Key points

- > Inspections: mechanical, electrical, battery
- > Dust removal / equipment cleaning
- > Software updates
- > Electronics testing
- > Environmental checks
- > Battery check*
- > Communication test
- > Maintenance report

**Only for UPS.*

Benefits

- > Helps reduce equipment malfunction
- > Optimises operating efficiency
- > Extends equipment lifetime
- > Improves system availability

Optional services for maintenance contract

Emergency services 24/7



shutterstock.com

The response time to site is vital for business continuity; limiting as much as possible any downtime, in order to avoid any risk of severe system anomaly.

It is, therefore, essential to have the expertise of a maintenance service provider who fully understands your equipment, knows your working environment and who can respond to emergencies within a time guaranteed by a bespoke Service Level Agreement (SLA).

Proximity and emergency service carried out by the manufacturer are the best guarantees for fast troubleshooting and real problem solving.

Key points

- > Specialist team of engineers on call 24/7
- > Technical expertise on-site within 4 hours* guaranteed
- > Remote monitoring and proactive troubleshooting with SoLink
- > 24/7 original spare part stock availability with high priority shipment

** Please check the service coverage in your area.*

Benefits

- > High quality technical support
- > Fast and precise diagnostic
- > Real problem solving

Optional services for maintenance contract

SoLink - Socomec experts 24/7 UPS remote monitoring



SoLink is one of the services included in a Socomec Maintenance Contract. When the application is critical, you can be assured of immediate and expert attention via SoLink. SoLink will automatically identify the anomaly and notify the nearest Socomec Service Center when the UPS' operating parameters fall outside the permitted range - providing you with a permanent and direct connection to Socomec's expert technical team.

Restore your systems in record time

Proactive alarm clock: When your UPS alarm is activated, SoLink will instantly notify the nearest Socomec Service Center. The supervisor technician will carry out an initial check-up by accessing the UPS dashboard on the cloud platform.

Remote troubleshooting: In the event that more in-depth analysis is required, a Socomec expert engineer will connect to your UPS through remote access in order to run tests and diagnostic tasks directly on your machine, in complete security.

First-time-fix intervention: In the event that on-site intervention is required a Socomec on-call engineer will be dispatched immediately with a full brief from the Socomec Service Center, along with any spare parts that may be needed.

Improve future performance

Periodic reporting: Socomec experts will provide you a periodic UPS health-check report with event statistics, trend analysis and technical recommendations to improve overall system availability.

Interactive web dashboard: The IoT cloud-connectivity allows you access to an intuitive, interactive dashboard that gives a view of the equipment's historical data and performance trends.

SoLive App: Remote UPS monitoring from a smartphone - anytime, anywhere. With real-time alarm notifications and detailed status updates for each UPS, it's not possible to manage unexpected events and develop a real insight into the operating environment.

Key points

- > Effective: if an anomaly occurs, MTTR is drastically reduced
- > Secure: data is hosted on Socomec-owned cloud infrastructure, Cyber security is certified by a third-party company
- > Affordable: proposed as an optional extra on the Maintenance Contract at an attractive price



Benefits

- > Prevents problems from occurring
- > Increases system availability
- > Saves downtime costs

Optional services for maintenance contract

SoLink - Socomec experts 24/7 UPS remote monitoring

Provide a unique user experience

Remote trouble shooting

Initiate problem solving in complete security

The Socomec technician is available upon request - and in collaboration with the end-user - to remotely access the UPS. This means that diagnostic tasks can be conducted in a more precise way and problem solving interventions can be initiated, as if in front of the machine.

Direct expert access to your UPS.
Root cause analysis - with no downtime
Issue detection in real-time.
Remote tasks can be run within cyper security products.

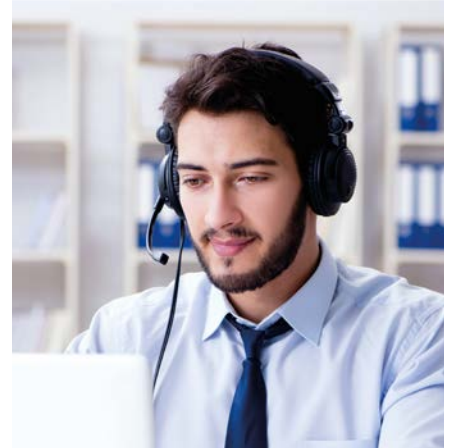

Interactive web dashboard

Historical UPS data is just a click away

Verifying your UPS performance is now an innovatedigital experience with the new SoLink interactive web dashboard.

Visualise the data history for the main operating parameters.
Select your period (hour/day/week/month/year).
Choose the sampling frequency of the measurement.
Zoom in on the graph to see the detail.

SoLive UPS

Live UPS data always in hand

While SoLink is supported by experts ready to intervene on your behalf, you can access information about the status of your UPS directly from your smartphone with SoLive UPS!

Data provided:
current UPS status,
battery level,
battery back-up time (minutes),
UPS operating temperature



Download SoLive UPS app:



Optional services for maintenance contract

Remote troubleshooting problem solving securely and instantly

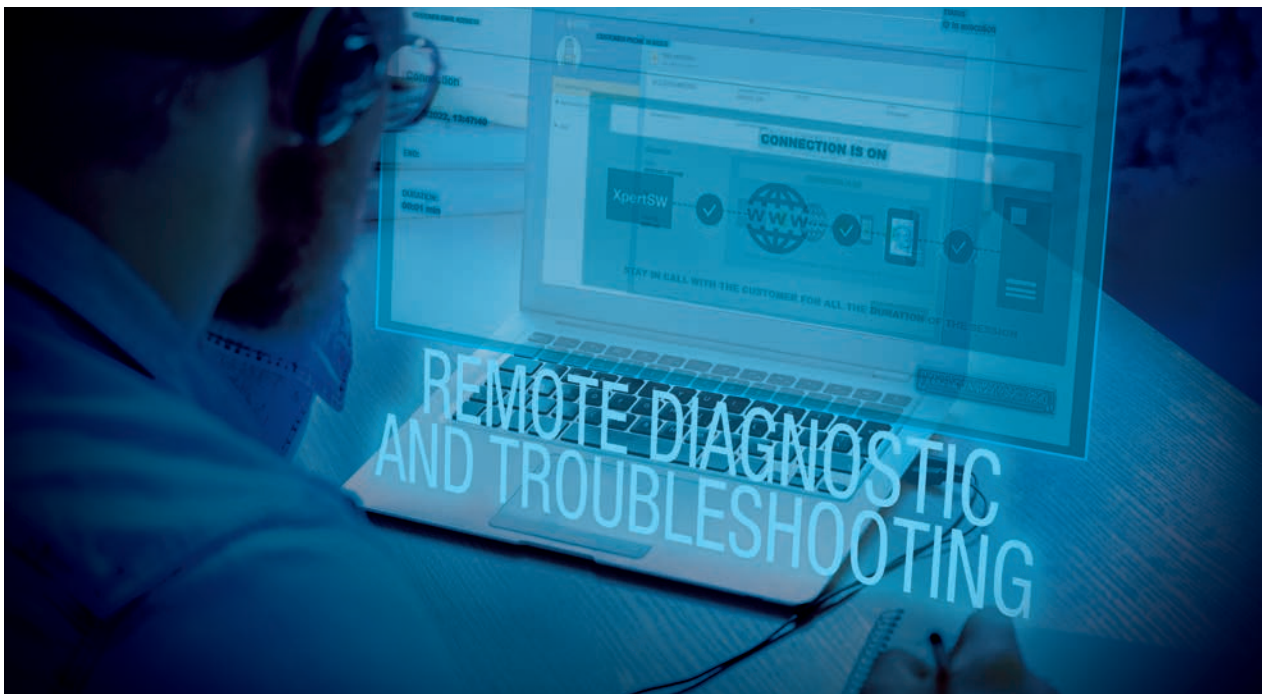

As soon as a problem occurs, Socomec's expert engineers are available upon request - and in collaboration with the end-user - to conduct diagnostics and root cause analysis, restoring the system in record time. The engineer connects to the UPS through remote access in order to run tests and diagnostic tasks directly on the machine - in complete security.

Problem solving interventions can be carried out with the same efficiency as if in front of the equipment.

Fast intervention

- Easy scheduling activity.
- Direct remote access to the UPS in order to solve issues at distance.

Access to the best experts

- These fuses offer increased reliability, ensuring consistent performance over time. Their silver-based composition protects them from premature ageing, making them perfectly suited to the cyclic operations characteristic of energy storage application.

Real-time issue analysis

- Remote diagnostics and tests are as effective as if in front of the UPS.
- Fast root cause analysis

Reduced costs and carbon impact

- Time saving.
- More cost effective and eco friendly than on-site intervention

Contact us to find out which UPS ranges and models are compatible with this service.

Key points

- > Direct access to UPS
- > Immediate response time
- > Same level of service as with on-site intervention
- > Issue analysis in real time
- > On-demand encrypted connection
- > Cyber security audit by certified independent organisation
- > Available under maintenance contract

Optional services for maintenance contract

Consumables replacement



appx_1005.eps

The components of each equipment are designed to operate reliably during the product's normal lifecycle, in the electrical environments and environmental conditions stated in the installation and operating manual.

To reduce the impact of ageing on your system, which could affect the efficiency and availability of the installation, it is vital to carry out the regular preventive replacement of parts subject to wear and tear such as fans and capacitors for UPS, and fans for STS, COSYS and MEDSYS products.

Key points

- > Original spare parts

Benefits

- > Prevents equipment instability and malfunctions
- > Avoids risk of system breakdown
- > Saves downtime costs



Fans and capacitors must be replaced by qualified personnel only. Only Socomec personnel are authorised to make recommendations for any replacement parts.

Optional services for maintenance contract

Battery care ⁽¹⁾



(1) Only for UPS.

Batteries are a key element of UPS systems. Their efficiency and availability are important for preventing load downtime, but at the same time batteries are the most vulnerable and failure-prone component of such systems.

Battery failures are mainly caused by the premature “end of life” of a few battery blocks. A corrupted battery block, if not detected early and not replaced, can accelerate ageing within the rest of the battery string, therefore jeopardizing the integrity of the system.

The level of predictability for failure detection on a battery block depends on the number of measurements, tests and analyses that are performed on every single block.

Main factors for the premature end-of-life of battery blocks:

- High temperatures
- Frequent number of cycles
- Discharge too deep
- Recharging with high voltage
- Lack of regular maintenance

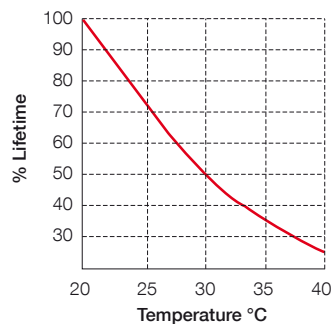

Source: Eurobat

sydfr_2088_a_gp

Key points

- > Impedance test, thermal imaging, temperature, voltage measurement block by block
- > Faulty / weak block detection
- > Back-up time measurement (optional)

Benefits

- > Information on the battery's state of health
- > Estimation of the optimum time for battery replacement
- > Optimization of the battery's useful working life

Battery Care is a brand new set of service packages that complements the standard battery check service (at string level) during the UPS preventive maintenance visit.

The packages will ensure the integrity of your business continuity by performing the highest level of inspection on your battery blocks.

Features:

The Battery Care offering is designed around 3 packages: IMP (IMPedance), TEMP (TEMPerature) and PRIME (the full package).

ACTIONS	WHERE	BATTERY CHECK	BATTERY CARE		
			IMP	TEMP	PRIME
Visual inspection check for leakage and corrosion	string	•	•	•	•
Cleaning	string	•	•	•	•
Measurement with partial discharge of V & I	string	•	•	•	•
Environment temperature check	string	•	•	•	•
Control of floating voltage and max current*	string	•	•	•	•
Impedance test	each block		•		•
Temperature measurement	each block			•	•
Voltage measurement*	each block			•	•
Thermal imaging	each block				•
Torque setting	each block				•
Back-up time measurement**	string		○	○	○

•: inclusive.

○: optional.

* during battery charge. **: by performing the end of discharge voltage test.

Depending on the package chosen (IMP, TEMP, PRIME), a set of accurate measurements, tests and analyses will be performed on each single block across all battery strings by Socomec trained engineers.

An in-depth report will provide information about:

- the health of each single battery string / block,
- the faulty blocks that need to be replaced,
- the real "back-up time" of the battery system (optional).

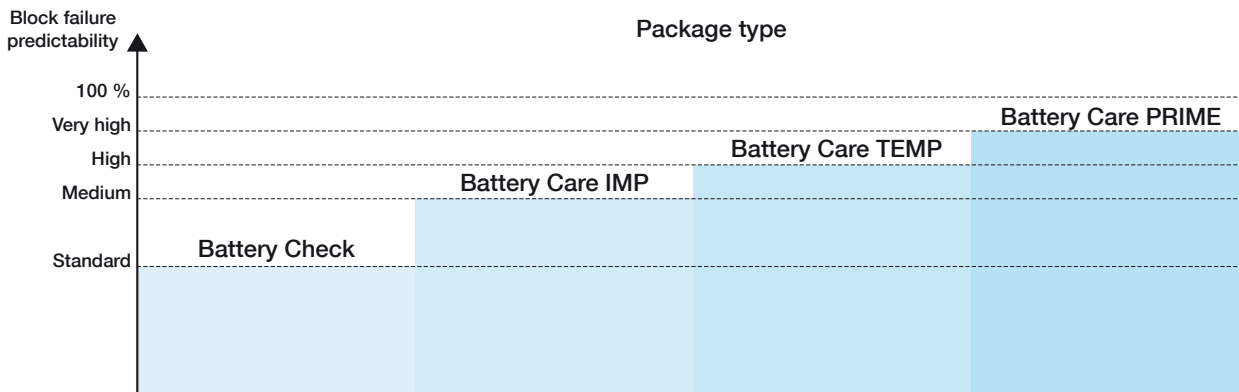

svc 007 en gb

Do you know your real back-up time ?

- > For various external factors, your real back-up time could be much less than the one declared by the battery manufacturer.
- > Thanks to a specific set of measurements and analyses, Socomec can provide you with the exact back-up time of your battery system.

Optional services for maintenance contract

Battery replacement ⁽¹⁾



(1) Only for UPS.

The majority of batteries used in UPS applications (VRLA - Valve Regulated Lead Acid) normally have a calendar life of 5-10 years, depending on the local operating conditions. The calendar life is the actual time span from the date of installation until the end of life, when battery capacity drops below 80% of its rating. VRLA batteries that are well maintained and installed in a properly conditioned environment, typically have a service life of 70% to 80% of their calendar life. This explains why the UPS back-up time could differ from the one declared by the battery manufacturer.

For the integrity of business continuity, it is essential to know the estimated end-of life of the battery system and to be correctly advised concerning the best time for its replacement.

The expertise of the UPS manufacturer is the best guarantee for carrying out any battery replacement operations. An expert that understands your equipment and how it is integrated into your unique working environment and who can respond effectively to any anomaly should any occur.

Key points

- > Checking and recalibration of battery charger setting
- > Fully secure battery discharge test
- > Battery disposal according to local regulations

Benefits

- > Prevents unexpected early shutdown of the UPS
- > Saves downtime costs
- > Advice for the optimisation of the battery back-up time

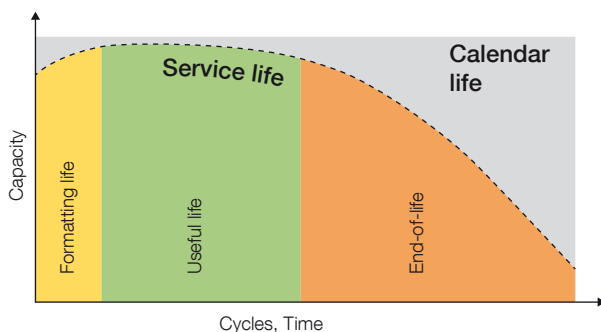

The battery is a critical component of the UPS system: according to a study by the Ponemon Institute, 65 % of Uninterruptible Power Supply (UPS) system failures are due to batteries. The reliability and availability of these components are vital to ensuring the energy supply to the load.

In the case of a failure, the economic impact of an outage can dramatically increase to hundreds of thousands of euros for the UPS owner.

Within the UPS system, the battery represents the weakest and least sophisticated component, while its cost represents an important part of the investment. It is therefore crucial to reduce the number of maintenance operations, maximise the battery's return on investment and anticipate battery malfunctions.

This can be implemented by following the rules described in the IEEE standard 1188 (IEEE Recommended Practice for Maintenance, Testing and Replacement of Valve-Regulated Lead-Acid (VRLA) Batteries for Stationary Applications), whilst a more accurate preventive maintenance program can be carried out using a BMS (Battery Monitoring System) which provides all the parameters of the individual battery blocks, continuously checks the battery's efficiency and identifies anomalies in advance.

Main reasons for battery block failures

For a battery operating in real life conditions, there are 4 types of failures which can create a defective block:

1. Early failures, which are mainly due to defects introduced during the manufacturing process. They generally appear during the first discharge cycle.
2. Random failures, which can appear at any time during the life of the battery.
3. Premature failures.
4. End-of-life failures, both of which are due to latent defects or environmental conditions, such as a high ambient temperature, which can shorten the battery's operational life time. If this type of failure appears, it means that the health of the battery string is seriously compromised and the battery cannot be relied upon for autonomy.

What is a battery ?

A battery is made up of a collection of:

- > blocks (typically 12 VDC), which can be assembled in series to form a string,
- > several identical strings, which can be assembled in parallel to form a battery.

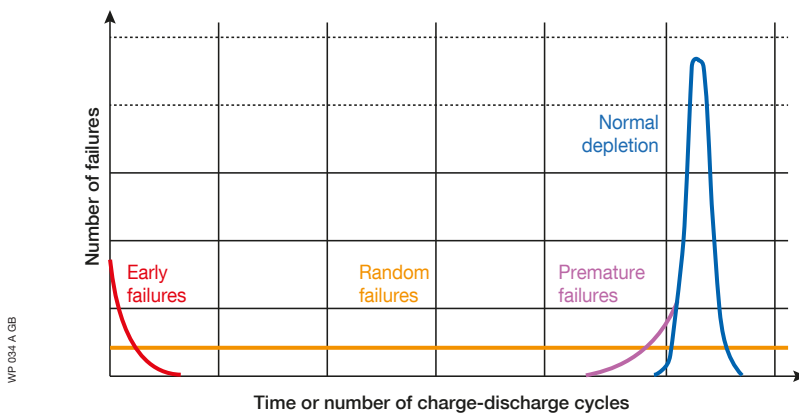
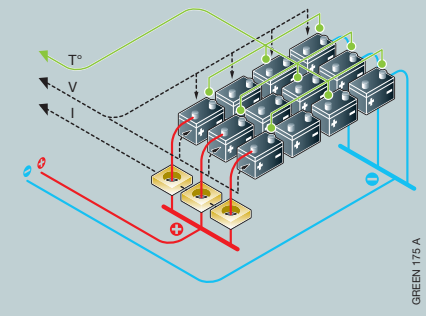

Block failures description.

Customer training

Certified manufacturer's training programme for UPS and STS



Socomec specialists can help you gain the necessary skills to operate your equipment efficiently and to increase its availability.

Socomec technical training courses can take place either at your site or in Socomec's dedicated training centre.

Available on MASTERYS, MODULYS, DELPHYS, STATYS and communication products.

Key points

- > Practical training
- > Either in Socomec factories or at customer's site
- > Open discussions and participants' feedback
- > Many types of configurations covered
- > Real-case simulations based on customer's actual installation
- > Experienced 'field-tested' trainers

Benefits

- > Helps you to really know your equipment
- > Real "hands-on" practice on your UPS
- > Understand the alarms





Services for Switching Equipment

Commissioning

ATYS Automatic Transfer Switch p. 416

Maintenance and inspection contracts

A broad range of solutions to suit all your needs..... p. 417

Inspection contracts

ATYS Automatic Transfer Switch p. 418

Single services

Inspection visit for ATyS Automatic Transfer Switch..... p. 419

Commissioning

for ATyS Automatic Transfer Switch

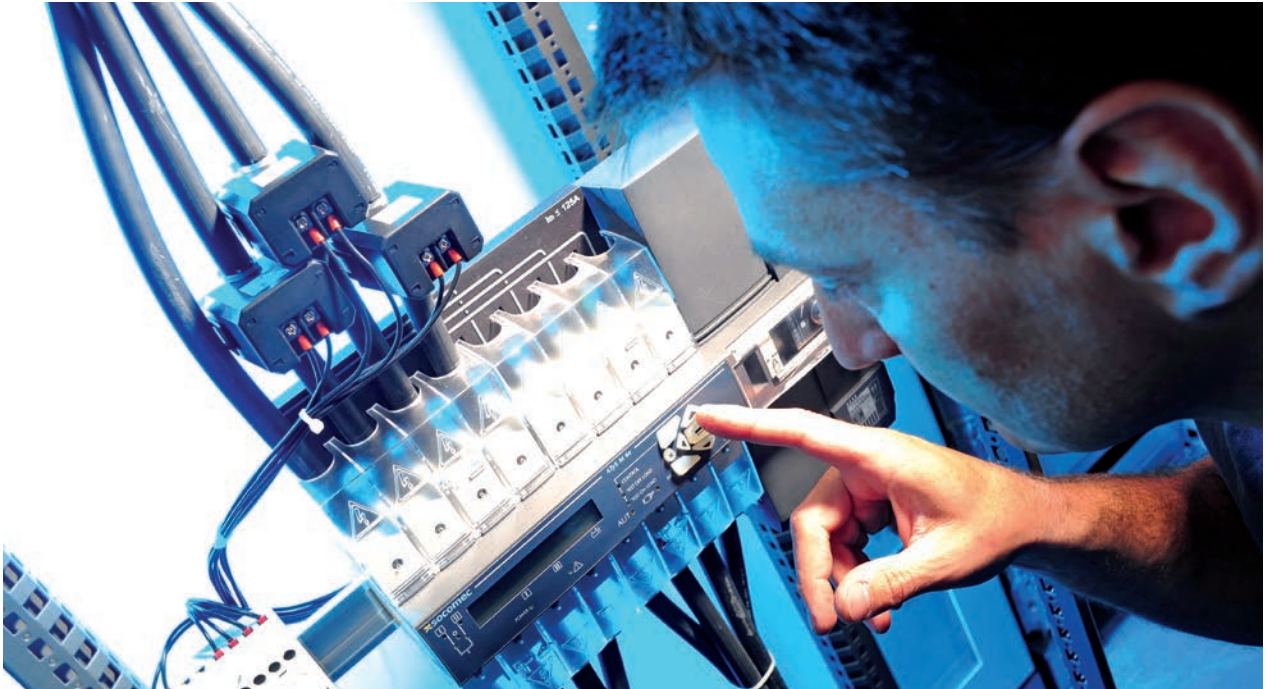

app01_514_atp01

To enable you to quickly get your system up and running, we check the installation, carry out commutation tests and make the necessary equipment settings.

References

ATyS commissioning

price on request

Key points

- > Settings and configuration to suit your needs
- > Switching test
- > Communication test
- > Handover summary / briefing on how to use the ATyS
- > Service report with overview of installation parameters

Benefits

- > Checking installation compliance
- > Guaranteeing full functionality in the various operating modes

Maintenance and inspection contracts

A broad range of solutions to suit all your needs



The Maintenance service contracts are entirely tailored around customers' needs, taking into account individual operating constraints, business activity and the unique level of criticality associated with specific applications.

A variety of contracts suitable for users have been developed to cover all needs: from a simple combined service, to a fully-inclusive package that includes the cost of labour and spare parts and delivers the quickest response time to site.

		SILVER	GOLD	PLATINUM
Automatic Transfer Switches ATyS		•	•	•

Inspection contracts for ATyS Automatic Transfer Switch



In addition to the inspection visit for ATyS changeover switch, it is possible to sign for an inspection contract, according to your operating constraints. It can be combined with your UPS contract.

SERVICE DESCRIPTION	INSPECTION CONTRACTS		
	SILVER	GOLD	PLATINUM
1 inspection visit	•	•	•
Thermal imaging	•	•	•
Test on load	○	○	○
Load duty categorie checking	○	○	○
Bypass system inspected	○	○	○
Labour & mileage for corrective maintenance		•	•
Original spare parts			•
Test off load*	•	•	•

•: inclusive.
○: optional.
* if GS present on source 2.

References	
Inspection contract SILVER	923 302 7000
Inspection contract GOLD	923 303 7000
Inspection contract PLATINUM	923 304 7000

Key points

- > An annual inspection visit by a Socomec engineer certifying that the ATyS switch is functioning correctly
- > A detailed inspection report provided after each inspection
- > A list of every asset tested and detail of the inspection work carried out
- > Highlight any issues found

Benefits

- > High power availability guaranteed and performance optimised
- > Reduced risk of potential faults going undetected
- > Costly downtime and the risk of operating losses are cut

Single services

Inspection visit for ATyS Automatic Transfer Switch



A routine inspection of the transfer switches by qualified personnel is required to meet the requirements of insurance companies and to ensure the optimal operation of critical applications.

The inspection visit for ATyS comprises a site visit by a qualified Socomec engineer, which certifies that each transfer switch is functioning correctly.

After each inspection and testing procedure the engineer will provide a detailed report and declaration of conformity.

Key points

- > Manufacturer seal of approval
- > Latest firmware updates
- > Complete report including technical recommendations
- > Declaration of conformity

Benefits

- > Guaranteed high power availability and optimum performance
- > Reduced risk of potential faults going undetected
- > Avoids costly downtime and operating losses

References

Inspection visit for ATyS

923 402 7000



Monthly consumption per use Electricity

From 20190401 00:00
to 20200401 00:00



Total over the period: 128641.47 kWh
Average over the period: 1608 kWh





Services for Power Monitoring and Measurement

Commissioning

DIRIS multi-function meter, DIRIS Digiware power metering system	p. 422
WEBVIEW-L power monitoring software	p. 423

Customer training

WEBVIEW-L software	p. 424
--------------------------	--------

Commissioning

for DIRIS multi-function meter,
DIRIS Digiware power metering system



To enable you to get your system quickly up and running, we check the installation, carry out communication tests and configure the equipment.

References	
Commissioning DIRIS / DIRIS DIGIWARE architecture	923 101 1200
Options	
Help with configuring the DIRIS/DIRIS Digiware architecture	923 401 1200
Checking the metering consistency in the measurement chain	923 407 1100

Key points

- > Controlling the complete chain (equipment/ connection/magnetic cores)
- > Settings and function test
- > Communication test
- > Information on how to use your installed system
- > Service report with overview of installation parameters

Benefits

- > Installation compliance
- > Reliability of measured data
- > Tracking of settings

Commissioning

for WEBVIEW-L power monitoring software



app_509_a.eps

We help you configure your architecture and get to grips with the software so you can quickly get your system up and running.

References	
Commissioning H80 WEBVIEW L-100	923 101 3400
Commissioning H80 WEBVIEW L-200	923 101 3500
Options	
Help with configuring WEBVIEW L – at customer site	923 401 3000
WEBVIEW L training – at customer site	923 201 3000

Key points

- > Checking system prerequisites are met
- > Setting up measuring, circuit and data equipment
- > Training and help with setting up a hierarchy and a Photoview page
- > Configuring the Datalogger feature
- > Training on how to use your installed system
- > Service report with overview of installation parameters

Benefits

- > Saves time during installation
- > Quickly get to grips with software features
- > Using and configuring the software

Customer training

on WEBVIEW-L software



The training module on how to use the WEBVIEW-L gives you full control over your settings so you can create reports, charts, mappings and monitor all your energy readings.

References	
WEBVIEW L training – at customer site	923 201 3000
Training Basics of industrial communication	consult us
Training on the energy quality	consult us

Key points

- > Overview of communication equipment, standards and protocols
- > Introduction to H80 gateways and the WEBVIEW-L software
- > Creating and managing data profiles
- > Configuring Modbus-communication devices
- > Configuring the Datalogger feature
- > Creating hierarchies and PhotoView pages
- > Software configuration
- > Practical exercises based on your configuration

Benefits

- > Independently set up and use the energy data from your power monitoring architecture



Services for Energy Storage Systems

Preventative maintenance

Energy storage system SUNSYS HES L *p. 428*

Extended warranty

Energy storage system SUNSYS HES L *p. 430*

SoLive PRO

Energy storage system SUNSYS HES L *p. 432*



Preventive maintenance

for energy storage systems SUNSYS HES L and SUNSYS HES XXL



Preventive maintenance is vital in order to ensure that your energy storage system is operating at peak efficiency. If you subscribe to an extended warranty for your system a preventive maintenance contract is mandatory.

Adapted to your budget

- We offer several options that may or may not be selected when subscribing to the service.
See options detailed on the next page.

Optimization tips

- When our experts share the preventive maintenance report with you, they also provide advice in order to help you improve the use of your system and its operating environment.

Autonomy - a la carte -

- Depending on your desire and your skills, we can empower you by providing training in specific maintenance operations so that you can carry out some activities yourself.

Speed of intervention

- If you want a turnkey solution, our experts take care of everything. They take care of preventive maintenance from its planning to its completion in order to guarantee the reliability of your system, to maximize its lifespan and to limit corrective operations.

A solution for

- > Commercial and industrial buildings
- > Electric vehicle charging stations
- > Isolated microgrids
- > Resilient microgrids

Key points

- > Several options available to adapt the offer to your budget
- > Personalized support from our experts according to the desired level of
- > Tips to improve your performance

Preventive maintenance

for energy storage systems SUNSYS HES L and SUNSYS HES XXL

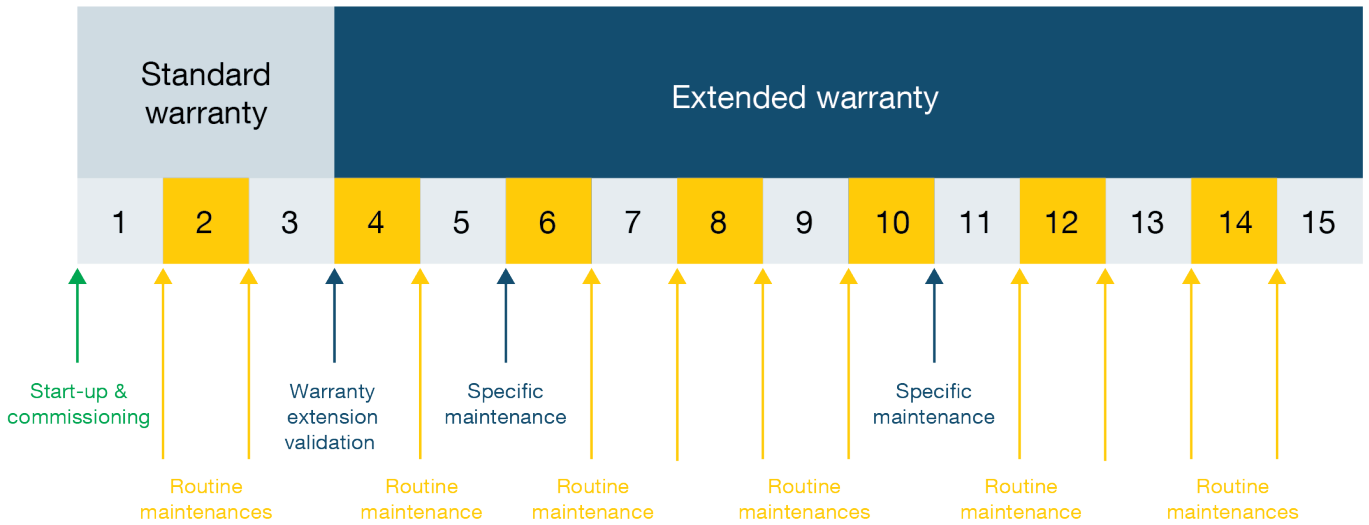

Preventive maintenance - optimizing the lifespan of your system!

To guarantee optimal system operation, periodic maintenance by an expert is essential. This is the best way to ensure the reliability of your system over its lifetime.

2 modular offers are available:

- **DIY partner package:** an offer favoring cost reduction but also requiring input from you.
- **Complete Socomec package:** a complete offer for your peace of mind, where we take care of everything.

	DIY PARTNER PACKAGE	COMPLETE SOCOMEK PACKAGE
Routine maintenance visits carried out by Socomec		Included
Specific maintenance visits carried out by Socomec	Included	Included
Preventive maintenance visit report with recommendations	During specific maintenance visits	Included
Labor included	During specific maintenance visits	Included
Parts for specific and routine maintenance operations	Option	Option
Training in routine maintenance operations	Included	
Software update	During specific maintenance visits	Included

(7)

Extended warranty

for energy storage systems SUNSYS HES L and SUNSYS HES XXL



Warranty extensions are available to provide a total warranty of up to 20 years for your battery or the complete storage system, depending on your needs. They include the corrective maintenance of your covered items (parts included) as well as a follow-up of your requirements.

Full coverage of your system

Benefit from an extended manufacturer's warranty of up to 20 years, depending on your needs.

Controlled budget

You know the price of the warranty extension from the outset and, with just one payment, you can therefore avoid unforeseen costs.

Battery performance warranty

The warranty extension includes a performance warranty on the battery. This is the warranty of a DC residual energy level depending on the battery use.

Speed of intervention

In the event of a breakdown, our experts provide you with a rapid response: within 1 day for initial telephone support and within 1 week for an on-site visit, if this is required.

A solution for

- > Commercial and industrial buildings
- > Electric vehicle charging stations
- > Isolated microgrids
- > Resilient microgrids

Key points

- > Full coverage of your system
- > Battery performance warranty
- > Controlled budget
- > Speed of intervention

What does the extended warranty cover?

- Corrective maintenance of the complete system or just of the battery, depending on the chosen warranty, (repair or replacement of defective parts), including parts replaced, the labour on site as well as travel and accommodation costs⁽¹⁾.
- Battery performance warranty.
- Assistance from our team of experts in the event of a problem, with a quick response.

What are the qualifying criteria?

- A preventive maintenance contract must be subscribed.
- Equipment must be permanently connected to the Internet, enabling access to battery data history.
- Socomec must be able to retrieve all data coming from battery at any time.
- Socomec can store all battery data on a secure cloud network on behalf of the customer.
- If the customer prefers to store the battery data himself, the customer assumes all responsibility. In the event of a problem with battery data storage managed by the customer, Socomec reserves the right to cancel the extended warranty.

A warranty adapted to your needs

To offer you greater flexibility with your warranty, we offer various options:

- Extended warranty applicable to the complete system,
- Extended warranty applicable to the batteries only,
- Warranty extension up to 20 years.

⁽¹⁾

SoLive PRO

Real-time system data processing and visualization in the cloud



SoLive PRO makes it easy and secure to visualise real-time data from your SUNSYS energy storage systems, across any of your sites:

- visualise your data via predefined or customised dashboards,
- enhance the performance and sustainability of your energy storage equipment.

Real-time advanced data visualisation

Access relevant and precise data from your Socomec equipment, available via ModBus TCP and Modbus RTU protocols, through practical dashboards.

- Detailed alarm notifications via push email messaging with personalised thresholds according to your needs.
- Live notifications of status changes.
- Historic data logs.
- Equipment locations.

Certified security

Your sensitive data is protected and stored on an ISO27001 certified sovereign French cloud ensuring:

- compliance with specific regulations regarding data protection and security,
- maximum protection against unauthorised access by foreign entities,
- guaranteed data confidentiality.

Customised* dashboards reports

User-friendly and easy to read, access your data via standard or customised dashboards:

- define your own KPIs with our responsive web application,
- set personal thresholds,
- enable multi-account functionalities and allow users to define their preferences and settings.

As well as enhancing your user experience, SoLive PRO provides unparalleled flexibility when monitoring and managing your electrical installations.

* To learn more about customisable dashboard options from Socomec, please contact the Service team.

A solution for

- > Detailed visualisation of all equipment data from different sites, integrated in one location for easy and secure access anywhere, anytime.
- > Centralised synoptic view of key information such as SOC, temperature and alarms.
- > Straightforward and reliable real-time access to your equipment's performance data and historic logs.
- > Data highly secured.

Power testing & certification

Tesla Lab



Tesla Lab - Power Testing and Certification is an independent laboratory specialized in testing of LV switchgears, components and switchgear assemblies.

Thanks to a wide range of equipment and experience in electrical, mechanical, climatic and functional tests for low voltage operating, control, safety and measuring equipment, Tesla Lab can relieve you of all the administrative steps involved in a large number of certification procedures.

It will take care of the contacts with the certification bodies as well as monitoring the procedure through to the obtaining of the certificate.

Tesla Lab is accredited by



and regularly works in partnership with the international certification bodies: KEMA, CEBEC, UL, CSA, ASTA, Lloyd's Register of Shipping, Bureau Veritas, BBJ-SEP, EZU, GOST-R, ...

Key points

- > Several categories of tests: short-circuit tests, verification of temperature rise, overload of endurance tests
- > Several standards covered: IEC, EN, UL, CSA

Benefits

- > No need to have multiple contacts to test your products for compliance in multiple markets



Tesla Lab: Your passport to success

Socomec: our innovations supporting your energy performance

1 independent manufacturer

4,400 employees
worldwide

8 % of sales revenue
dedicated to R&D

400 experts
dedicated to service provision

Your power management expert



POWER
SWITCHING



POWER
MONITORING



POWER
CONVERSION



ENERGY
STORAGE



EXPERT
SERVICES

The specialist for critical applications

- Control, command of LV facilities
- Safety of persons and assets
- Measurement of electrical parameters
- Energy management
- Energy quality
- Energy availability
- Energy storage
- Prevention and repairs
- Measurement and analysis
- Optimization
- Consultancy, commissioning and training

A worldwide presence

12 production sites

- France (x3)
- Italy (x2)
- Tunisia
- India
- China (x2)
- USA (x3)

30 subsidiaries and commercial locations

- Algeria • Australia • Austria • Belgium • China • Canada
- Dubai (United Arab Emirates) • France • Germany
- India • Indonesia • Italy • Ivory Coast • Malaysia
- Netherlands • Poland • Portugal • Romania • Serbia
- Singapore • Slovenia • South Africa • Spain • Sweden
- Switzerland • Thailand • Tunisia • Turkey • UK • USA

80 countries

where our brand is distributed

SOCOMEK, Inc.

9 Galen Street, Suite 120
Watertown, MA 02472
Tel. 617 245 0447
Fax 617 245 0437
info.us@socomec.com

YOUR DISTRIBUTOR / PARTNER

www.socomec.us

